

*Book of Proceedings*

**February 12-14, 2020**

---

**Papers and Proceedings –  
Fiftieth Annual Meeting of the  
Southeast Decision Sciences  
Institute 2020**

---





**SOUTHEAST DECISION SCIENCES INSTITUTE**  
ANNUAL MEETING  
February 12-14, 2020

## Proceedings

Program Chair:  
Dr. Ping Wang (James Madison University)



## Welcome to the 50th Southeast Decision Sciences Institute Conference

On behalf of the council, officers, 2020 program committee and the 50th anniversary celebration committee, I would like to take this opportunity to express my deep appreciation to SEDSI Council Chairperson Jim Wynne and the SEDSI Council for their confidence in me as the program chair. Many thanks go to each author, co-author, presenter, reviewer, session chair, track chair, sponsor, keynote Speaker, President's Award Luncheon Speaker, Chancellor, Dean, Journal editor, workshop and poster presenter, the 24 former and current SEDSI Presidents, the four former and current DSI Presidents, DSI Executive Director, participant and supporter. Your contribution, presence and teamwork made the great success possible for this 50th annual conference of the Southeast Decision Sciences Institute (SEDSI) in Charleston, SC.

SEDSI 2020 received twice as many submissions, had twice as many sessions and presentations, and had over 100 first-time SEDSI attendees - the highest ever for the regional conference.

Many thanks to the 361 authors and co-authors, and special sessions panelists, 24 of them from non- USA countries, of 170 institutions from 17 countries, who submitted a total of 209 papers, workshops or special panels - almost twice as many as those in the past. There were over 233 presentations, workshops or special panels in 78 sessions for the conference - almost twice as many as those in the past. Many thanks for 258 registered attendees for the conference. Over 100 of them experienced their first time to SEDSI. Special thanks to the 69 reviewers with the number of papers reviewed from 1 to 28. 7 reviewed more than 10 papers, 22 reviewed 4 to 9 papers, and 41 reviewed 1 to 3 papers. Many of the reviewers were not volunteered, but willingly conducted reviews. Each track chair contributed significantly to the conference for the twice as many of submissions in their tracks. We are very grateful for their time and effort to promote the conference, conduct paper reviews, organize sessions and oversee the presentations during the conference.

It was very important to note the SEDSI 2020 would not be so successful without the continued and tremendous support from our institutional sponsors and exhibitors. Our sponsors provided the highest amount of their sponsorships ever. If you looked at the colleges and universities that sponsored the conference, you should find these were the institutions which SEDSI Council members and officers belonged to. We were very fortunate to have the great support from the exceptional SEDSI leadership teams. Their trust, encouragements, timely advice and effort to obtain the highest level of sponsorships from their home schools spoke loudly to their commitment and leadership for the institution.

Other highlights of the conference also include:

- We were very fortunate that Dr. Sang Lee, the SEDSI Distinguished Founding President, and the other 23 former and current SEDSI presidents and some of their deans attended the 50th anniversary celebration. They deserve special appreciations for their many years of services and contributions to SEDSI. Their presence made the conference very special indeed. Among the 24 Honorable former and current SEDSI Presidents were the SEDSI Distinguished Founding President Sang Lee (1971-1972), Joseph G. Van Matre (1980-1981), Terry Rakes (1987-1988), James A. Pope (1989-1990), Robert L. Andrews (1991-1992), Brooke Saladin (1992-1993), A. James Wynne (1995-1996), Hope M. Baker (1999-2000), Drew Rosen (2001-2002), Ina



Markham (2002–2003), Chandrashekar Challa (2004-2005), William (Bill) Carper (2005-2006 and 2006-2007), Dr. Amit J. Shah (2008-2009), Barry Wray (2009-2010), Quinton J. Nottingham (2011-2012), George Lowry, (2012-2013), Christopher (Chris) Zobel (2013-2014), Kellie B. Keeling (2014-2015), Jason Deane (2016-2017), Suzie Smith (2017-2018), Reza Kheirandish (2018-2019), Tobin Turner (2019-2020), and Cheryl L. Aasheim (2020-2021).

- We were grateful for the continued support from DSI and enjoyed the presence of the four Honorable former and current DSI Presidents: Sang Lee (1984-1985), Terry Rakes (1998-1999), Barbara Flynn (2003-2004), and Janet Hartley (2019-2020) and DSI Executive Director Vivian Landrum.
- We really enjoyed the Special Presentation of University Chancellor at the President’s Reception by Dr. Larry Clark, Chancellor of Louisiana State University Shreveport, to share his insights of future higher education.
- At the beginning of the conference, over 80 attendees attended the keynote “Artificial Intelligence in 2020: Five Trends to Watch” by Heather Domin, Program Manager and Technical Advisor, AI Ethics at IBM’s Chief Privacy Office. We really appreciated Heather Domin for sharing her vision of the future of technology and business with us. Thanks UVA’s Institute of Data Science for holding their Women for Data Sciences Conference on March 29, 2019, that gave us the opportunity to meet our initial keynote speaker Ms. Rama Akkiraju, Head of IBM AI Operations, IBM Watson and IBM Academy of Technology. We appreciated Rama, Heather and IBM’s support to the conference.
- President’s Award Luncheon Speaker: Distinguished Interim Provost Frances C. Welch, College of Charleston.
- Attendees really enjoyed the Special Panels of College and School deans that shared their visions of future higher education in business: Michael E. Busing, Dean of College of Business, James Madison University; Robert T. Sumichrast, Dean of Pamplin College of Business, Virginia Tech; Peter Brews, Dean of Darla Moore School of Business, University of South Carolina; Chris Martin, Dean of College of Business, Louisiana Tech University; Nancy D. Albers, Dean of College of Business, Louisiana State University in Shreveport; Robert T. Burrus, Jr. Dean of Cameron School of Business, University of North Carolina Wilmington; Margaret Thompson, Associate Dean of College of Business, Clayton State University; Alex Koohang, Dean of School of Computing, Middle Georgia State University; Kai Koong, Dean of Brimmer College of Business and Information Science, Tuskegee University; Alan T. Shao, Interim VP of Corporate Partnerships and Dean of School of Business, College of Charleston; Michael R. Weeks, Dean of Tommy and Victoria Baker School of Business, The Citadel.
- Many attendees were grateful for the journal editors who provided constructive guidance and suggestions for publishing research at the Special Panels of Journal Editors, including *Expert Systems with Applications*, Editor-in-Chief Binshan Lin, Louisiana State University at Shreveport; *Decision Sciences*, Editor, Mark Ferguson, University of South Carolina; *Decision Sciences Journal Innovative Education*, Editor, Matthew Drake, Duquesne University; *Electronic Government, an International Journal*, Editor-in-Chief, June Wei, University of West Florida; *International Journal of Electronic Finance*, Editor-in-Chief, Jiaqin Yang, Georgia College and State University; *International Journal of Electronic Healthcare*, Editor-in-Chief, Kai S. Koong, Tuskegee University; *International Journal of Innovation and Learning*, Editor-in-Chief, Kongkiti Phusavat, Kasetsart



University, Thailand; *International Journal of Mobile Communications*, Editor-in-Chief, June Wei, University of West Florida; *Journal of Computer Information Systems*, Editor-in-Chief, Alex Koohang, Middle Georgia State University; *Journal of Supply Chain Management*, Co-Editor-in-Chief, Barbara B. Flynn, Indiana University; *Management and Production Engineering Review*, Deputy Editor-in-Chief, Joanna Paliszkiewicz, Warsaw University of LS; *The Sport Management Education Journal*, Associate Editor, David Shonk, James Madison University.

- We greatly appreciated all Track Chairs for promoting the conference, soliciting submissions and workshop proposals, scheduling sessions, and monitoring presentations. They included:

Accounting, Economics, Cryptocurrency and Finance - Michelle Hagadorn, Roanoke College.

Data Analytics and Statistics Instruction (DASI) - Robert Andrews, Virginia Commonwealth University, and Kelli Keeling, University of Denver. Many thanks go to Bob and Kelli for promoting and organizing eight DASI sessions with 25 presentations with an average of 24 attendees per session. I sincerely appreciated Bob for the many suggestions for the conference and for working with sponsors. Many attendees benefited from Bob's presentation tips. It was due to Bob's suggestion, that attendees enjoyed the interactions during the 15 - minute's breaks instead of 10 minutes at the conference. The teaching focus of the conference was inspired by the successes of DASI sessions in at SEDSI and DSI conferences.

Analytics, Big Data Applications, Business Intelligence, Data Mining, Statistics and Expert Systems - Binshan Lin, Louisiana State University at Shreveport. Binshan actively promoted the conference and organized sessions for the track. His effort led to 26 submissions for this new track. Binshan deserves special thanks for his many suggestions throughout the year about the special sessions for chancellor, deans and journal editors. He actively promoted the conference and obtained sponsorship. His efforts led to many first-time attendees at the conference.

Healthcare, Public Sector and Not for Profit Management - Elham Torabi and Helen You, James Madison University. The Healthcare management was an added area for the track. Elham and Helen actively promoted the conference. Their effort resulted in 20 submissions to the track. Elham also helped to invite journal editors, organized two workshops, and conducted a workshop on Simulation Game for Emergency Room operations. She brought her husband Masoud and their one year-old daughter Kiana to the conference. Kiana became the youngest attendee of the conference.

Hospitality, Recreation and Sports - David Shonk, James Madison University. Dave helped to promote the conference and invited the special speaker to this new track of the conference. David helped to promote SEDSI, led seven submissions, and invited the Teaching Award Winner for the presentation. Positive feedback from attendees in the track indicated a need to include the track in future conferences.

Information Privacy, Security and System Resilience Business Ethics and Business Law - Elena Olson, Virginia Commonwealth University.

Innovative Education, Assessment, Engaged Learning Curriculum, Teaching and Pedagogy - Ajay Aggarwal, Henderson State University. This track received the largest number of submissions of 42. Thanks Ajay for promoting the conference, organizing reviews and arranging sessions for the track.



IS, IT, Blockchain Technology, and Social Media - June Wei, University of West Florida.

Management, Strategy, Organizational Behavior Organizational Theory, and Human Resource Management - Sara Kiser, Alabama State University. Thanks Sara for organizing sessions for the track.

Marketing, Consumer Behavior, International Business - Rebecca Scott, University of North Carolina Wilmington.

Student Papers (Undergraduate, Master and Ph.D Students) - Elizabeth Rasnick, Georgia Southern University. Elizabeth deserves special thanks and recognitions because of the large number of students' submissions for competitions and her effort to recruit judges, organize the sessions and issue certificates for winners.

Sustainability, SCM, Quality Management, and Logistics — Hadi Farhangi, Savannah State University and Suman Niranjani, University of North Texas. Many thanks go to Hadi for providing many suggestions to actively promote the conference on INFORMS and Clemson University Web Servers, and thanks Hadi and Suman for organizing sessions for the track.

- Our sincere appreciations go to sponsors and exhibitors. Due to the lower registration fees - not sufficient to cover the expenses associated with the conference hotel and the conference, SEDSI 2020 would not be successful without the great support from our institutional sponsors and exhibitors, including:

Dean Michael Busing and James Madison University College of Business  
Department Head Art Gowan and JMU Computer Information Systems/Business Analytics  
Department

Dean Michael R. Weeks and The Citadel Tommy and Victoria Baker School of Business

Dean Grier and The Virginia Commonwealth University School of Business

Department Head Jim Wynne and VCU Department of Information Systems

Dean Robert T. Sumichrast and Virginia Tech Pamplin College of Business

Dean Robert T. Burrus, Jr. and Cameron School of Business of University of North Carolina  
Wilmington

Ms. Heather Domin and IBM /IBM Watson

Presbyterian College

Roanoke College

Dean Georgia Southern University, Allen E. Paulson College of Engineering and Computing

Dean Jacob Chacko and College of Business of Clayton State University

Dean Nancy D. Albers and the College of Business, Louisiana State University Shreveport

Randolph Macon College

- We thank each exhibitor for their continued support of the conference and instructions, including: Case Centre, FlexSim Software Products Inc., Hawkes Learning, JMP (division of SAS), and Minitab.
- Each member of the Program Committee deserved special recognitions.

My colleague Luis Novoa, the associate program chair, deserves special thanks for his effort to obtain the information of over 10,000 contacts from over 60 regional colleges and universities. In addition, his effort and time to prepare certificates and many other things to be done before



the conference, including loading all of the boxes, big metal screens, projectors, printer and so forth on the SUV, and driving most of the seven hours along the way to Charleston. Helping to install, test and uninstall the screens, projectors and adapters in each breakout room for presentations, and working with Katrina and Art at the reception desk all the time to deal with issues. And again helping to load all of the stuff to the SUV after the conference.

I was grateful for my colleague Leigh Mutchler, the Proceeding Coordinator and Editor, for helping a lot at the registration/reception area during the conference, for presenting her work on teaching introductory database: Focus on the Users' Perspective, and for her time and effort to prepare and compile the conference proceedings through many revisions.

Special thanks go to Drew Rosen, Local Arrangements Coordinator. Drew made the detailed arrangements for the conference, including the pre-conference site visit, the switching of the conference hotel, identifying and arranging breakout rooms, and arranging breakfasts, coffee breaks, Presidents reception and Presidents Award Luncheon. Thanks Drew to moderating the special chancellor's session to give attendees the opportunity to meet Chancellor Larry Clark to hear his view of the future of higher education. Drew's management of the budget was critical to the balance of the account and the success of the conference. We sincerely appreciate his effort and contributions for obtaining the sponsorship support from Dean Robert T. Burrus Jr. and the Cameron School of Business at UNC Wilmington and the sponsorship for Officers Reception from Dean Dr. Michael Weeks and the Citadel Tommy and Victoria Baker School of Business.

- I sincerely appreciated the great support from Council members and Officers. We were so grateful to be able to stand on their giant shoulders and share the great success with you.

Many thanks go to Jim Wynne for his trust, encouragements, suggestions, and help throughout the year, and for his promoting and obtaining support from his dean and faculty members. His effort led to one of the largest sponsorships from VCU School of Business and Department of Information Systems. Thank you very much Jim.

Thanks to Cheryl Aasheim for her many suggestions and for sharing her experience as a program chair. Upon Cheryl's advice, the conference focused more on improving instructions, workshops and the needs of junior faculty members. Whenever we had needs, Cheryl was ready to help, like leading the 50th Anniversary Celebration Committee, compiling information and preparing posters of former SEDSI Presidents and other related preparations, , bringing many easels and foams for posters for former presidents and for poster sessions, and always providing her support. I wish I had asked more advice from Cheryl. Thank you again Cheryl.

As the archivists for SEDSI web service, George Lowry and Pamela Schlosser did a great job to update the program information on demand, many times on daily basis. Their effort also led to the sponsorship from Randolph Macon College. George provided many suggestions for effective updating of conference information online, such as the use of errata sheet and shared links. George also managed the designing and printing of all name badges - multiple versions - used for the conference. Because of the tight schedule and constant revisions in the last-minute program adjustments, the final printing and reprinting had to be done with very short notice in the week before the conference. Thank you George for your contribution and service.





Ina Markham was instrumental in nominating me as the program chair; her trust and support, her many valuable suggestions for the special deans' panels and journal editors' sessions and her contributions led to the largest sponsorship.

Thanks Chris McCart for her many suggestions and for managing accounts for the conference and obtaining sponsorship. Thanks Suzie Smith for her suggestions and encouragements. Thanks Tobin Turner for his working with me on program for the Presidents' Award Luncheon and for his and Suzie's work on the great sponsorship from Presbyterian College. Thanks Reza Kheirandish for his encouragements and suggestions and his support that led to the sponsorship from Dean Jacob Chacko and The College of Business at Clayton State University. Many thanks also go to Vivian Landrum, executive director of DSI, and Maria Hunt, for their managing the registration process, providing help to locate photos of former presidents, providing weekly and many times daily updates for the registration and attendance information, and processing the registrations for sponsors and exhibitors. Thanks Janet Hartley, DSI President, and Vivian for their support and attending the conference. Thanks Shona Morgan for taking great photos and providing help for the 50th Anniversary Celebration.

- The support we received from colleagues in James Madison University played significant roles to the great success. Over 40 faculty and students (over one tenth of the total number of authors and co-authors) were authors and co-authors of over 20 submissions (about one tenth of the total number of submissions) and 26 of them (one tenth of the attendees) presented their work and support the conference. Many also served as reviewers and session chairs. JMU had the largest group of participants to the conference. The following was an outline of contributions from James Madison University, primarily through the College of Business.

My dean Michael Busing showed his extraordinary leadership and support at every turn during the unforgettable year. Dean Busing provided unwavering trust and support from the very beginning to the very end. Besides being one of the highest sponsorship for the conference, he provided suggestions to and moderated the special deans' panel, and presented at the 50th Anniversary Celebration, despite his very busy travels. Thank you so much Mike.

Art Gowan and the Department of Computer Information Systems/Business Analytics provided one of the highest sponsorships. Art worked with Dean Busing in an effort that led to the highest sponsorship ever for the conference. Art also led the team in the last few weeks and prepared all ribbons, posters, certificates and many other items, including the testing of projectors, orders of HDMI to VGA adapters, and so on. His office became a war room with all of the name badges, posters and other items on his floor and desks until the later evening that Monday. Art stayed behind the reception desk throughout the conference, ran around to solve problems and helped to uninstall and loaded all of the stuff on the SUV after the conference. None could expect his/her department head to do that much. I sincerely appreciated it Art.

Our department secretary Katrina Spickler did so many things within the short period of three or four weeks. She confirmed the list of certificates, posters for sponsors and exhibitors, ribbons, plaque for keynote speaker, and worked with JMU Copy Center to get them printed. She placed orders for the paper used for certificates, big screens, adapters, labels for name badges and their plastic holders, and many more. She worked until 5:30 to 6:00 pm on that Monday to get all of these items ready for the conference. Katrina worked tirelessly behind the



reception desk during the conference for registrations and other support. We appreciated her great contributions to the conference.

Dave Jones of JMU College of Business Technology Coordinator provided a demo session for using the projectors, adapters and screen, and prepared a new color printer and laptop for the conference.

Thanks Phil Dubose, the Emeritus Professor and former JMU College of Business Associate Dean, for providing the detailed list of questions for the special deans and provost panels, and for his many constructive suggestions and advice.

Thanks also go to Jerry Benson, the Emeritus Professor and former JMU Senior Vice President and Provost, for providing additional comments about the questions for the special panel of Chancellor.

Thanks Carrie Wood, Director of JMU College of Business Marketing and Communications, for providing the valuable advice and suggestions to communicate with potential sponsors. Her suggestions were part of the communications and promotions that resulted in the highest amount of sponsorship ever, two or three times higher than those in the past.

Thanks Bobby Vaziri for presenting his work on Statistical factors that attribute to winning in the National Basketball Association (NBA) and for providing help around the registration / reception area from time to time during the conference and being session chairs.

Thanks Shawn Lough for reviewing 16 papers for the conference.

Thanks Christie J. Liu, Associate Professor of JMU Library, for recommending Linda Champion, East Carolina University, as a special session speaker on assessment.

Thanks Lee Ward, Director of JMU Health Center, for his presentation on improving first year and lower income students' performance and for his help in inviting special speaker James Winfield to present on first generation students learning.

Thanks Hao Zhang, JMU ISAT Assistant Professor, for his workshop on Blockchain Technology.

Thanks Helen You, JMU Health Service Administration Assistant Professor, for her being the track co-chair for Healthcare Track, reviewer, student paper competition judge and for presenting two papers with her co-authors.

Thanks Bill Ritchie and his co-authors for presenting their works on Unpacking New Geospatial Tools for Supply Chain Pedagogy, Practice and Research; Linking Blockchain, Supply Chain, and Student Learning: A Classroom Exercise; and Teaching the Impact of Supply Chain on Project Management: An Experimental Exercise at a Porsche Restoration Shop. Also for bringing industrial partners and students to the conference. Joseph Kerski, the Education Manager at ESRI.COM - the largest GIS provider with over 8,000 employees, was very impressed with the conference and decided to come to SEDSI 2021. Thanks Bill and Joseph.

Thanks Mike Mitri for his presentation on Natural Language Processing, Data Visualization, and the Mueller Report.

Thanks Chia-Hsuan Yang, an Assistant Professor at JMU/ISAT, for her presentation on Characteristics of Communication Transmission Using Twitter during a Natural Disaster.



Thanks Diane Lending for presenting her work on Feeding the Pig: An Integrated System for Program Learning Improvement.

Thanks Amy Connolly for presenting her work on Roleplaying as a Pedagogical Tool to Deal With Complexity in IT Project Management.

Thanks Pam Y. Li for being a session chair and for presenting her work on Teaching Strategic Management to Hospitality Students.

Thanks John Guo and Ping Wang for presenting their work on Information Privacy, Security and System Resilience, Business Ethics and Business Law, and on Wielding Blockchain to Enhance Counterfeit Drugs Prevention in Pharmaceutical Industry: A Practitioners' Perspective.

Thanks Tom Dillon and his co-authors for presenting their work on Enhancing CIS Program Curriculum with Certifications.

Thanks Carl Larsson, Brooks Marshall, and Bill Ritchie for presenting their work on The Alumni Project: Fostering Student-Alumni Engagement in the Curriculum.

Thanks Abigail Wostbrock and her team for presenting a poster of their work on How health behaviors affect the academic performance?

Thanks JMU Copy Center and Printing Shop for expediting many requests from us.

Thanks JMU Library for loaning two projectors for the conference.

In summary, we enjoyed working with you for the great success of the conference. We sincerely appreciated your support, presence and accompany. Thank you all for the great opportunity to serve as your program chair for SEDSI 2020. I shall remember this amazing experience for years to come.

SEDSI has been providing the platform for us to exchange our research ideas, share our teaching experience and enjoy our catch ups with friends. We warmly invite you to come back to SEDSI again.

Best regards,

Ping Wang, Ph.D.  
2020 SEDSI Program Chair



## **Decision Sciences Institute**

The Decision Sciences Institute is a professional society dedicated to the development and application of quantitative and behavioral methods to administrative problems. Membership includes representatives from most of the functional areas of business. Through its journals, *Decision Sciences* and the *Decision Sciences Journal of Innovative Education*, along with national, international, and regional meetings, and other activities, the Decision Sciences Institute serves as a vehicle to advance and disseminate the theory, application, pedagogy, and curriculum development of the decision sciences.

### **Charleston, SC**

Charleston is one of America's oldest and most historic cities. The holy city (as Charleston is often called) played vital roles in both the revolutionary war and the civil war. Referred to as the holy city because of its many houses of worship; Charleston, and especially the historic downtown market area, has many historic buildings within a short walking distance. There are also ample opportunities to shop for that special memory. No trip to Charleston is complete without visiting the historic open-air market right outside the doors of your hotel. Enjoy your stay in historic Charleston and please come back often.

### **Special thanks to our Exhibitors and Sponsors**

James Madison University College of Business

JMU Computer Information Systems/Business Analytics Department

The Citadel

The Virginia Commonwealth University School of Business

The Virginia Commonwealth University Department of Information Systems

Virginia Tech Pamplin College of Business

Presbyterian College

University of North Carolina Wilmington

Roanoke College

Georgia Southern University, Allen E. Paulson College of Engineering and Computing

Clayton State University

Louisiana State University Shreveport College of Business

Randolph Macon College

IBM /IBM Watson

Case Centre

FlexSim Software Products Inc.

Hawkes Learning

JMP (division of SAS)

Minitab



## Officers

### **President**

Tobin Turner  
Presbyterian College

### **President Elect**

Cheryl Aasheim  
Georgia Southern  
University

### **Past President**

Reza Kheirandish  
Clayton State University

### **Secretary**

Sara Bliss Kiser  
Alabama State University

### **Program Chair**

Ping Wang  
James Madison University

### **Program Chair Elect**

Rebeca Scott  
University of North  
Carolina, Wilmington

### **Vice President - Finance**

Chris McCart  
Roanoke College

### **Vice President - Meetings**

L. Drew Rosen  
University of North Carolina -  
Wilmington

### **Vice President - Member Services**

Ali A. Nazemi  
Roanoke College

### **Vice President - Planning & Development**

Mauro Falasca  
East Carolina University

### **Vice President - Publications**

Shona Morgan  
North Carolina A&T University

### **Vice President - Student Services**

Laquanda Leaven  
North Carolina A&T University

### **Archivist & Web Services**

George Lowry  
Randolph-Macon College

### **Associate Archivist & Web Services**

Pamela Schlosser  
Roanoke College

## Advisory Council

### **2020-2022**

A. James (Jim) Wynne  
Virginia Commonwealth University  
Terry Rakes  
Virginia Tech  
Chris McCart  
Roanoke College  
Lance Matheson  
Virginia Tech  
Suzie Smith  
Presbyterian College  
Reza Kheirandish  
Clayton State University

### **2019-2021**

Jason Deane  
Virginia Tech  
Kellie Keeling  
University of Denver  
Quinton Nottingham  
Virginia Tech  
Barry Wray  
University of North Carolina  
Wilmington  
Christopher (Chris) Zobel  
Virginia Tech



## Past Presidents

1971-1972	Sang Lee	1996-1997	Stephanie S. Robbins
1972-1973	Merwyn Elliott	1997-1998	Edward R. Clayton
1973-1974	Thad B. Green	1998-1999	O. Maxie Burns
1974-1975	Laurence J. Moore	1999-2000	Hope M. Baker
1975-1976	Joseph F. Hair Jr.	2000-2001	Lance Matheson
1976-1977	Ted F. Anthony	2001-2002	Drew Rosen
1977-1978	Rolph E. Anderson	2002-2003	Ina Markham
1978-1979	Arthur G. Bedeian	2003-2004	Kirk Karwan
1979-1980	James M. Clapper	2004-2005	Chandrashekar Challa
1980-1981	Joseph G. Van Matre	2005-2006	William B. Carper
1981-1982	Mary Sue Younger	2006-2007	William B. Carper
1982-1983	Bernard W. Taylor III	2007-2008	Robert T. Barrett
1983-1984	K. Roscoe Davis	2008-2009	Amit J. Shah
1984-1985	Ronald Zigli	2009-2010	Barry A. Wray
1985-1986	Donald J. Messmer	2010-2011	Wesley M. Jones, Jr.
1986-1987	Carl Gooding	2011-2012	Quinton J. Nottingham
1987-1988	Terry Rakes	2012-2013	George Lowry
1988-1989	Betty Whitten	2013-2014	Christopher Zobel
1989-1990	James A. Pope	2014-2015	Kellie Keeling
1990-1991	William Hardy	2015-2016	Shanan Gibson
1991-1992	Robert L. Andrews	2016-2017	Jason Deane
1992-1993	Brooke Saladin	2017-2018	Suzie Smith
1993-1994	Joanna R. Baker	2018-2019	Reza Kheirandish
1994-1995	Kathy Fitzpatrick	2019-2020	Tobin Turner
1995-1996	A. James Wynne		



## Distinguished Service Award Recipients

Robert L. Andrews

Virginia  
Commonwealth  
University

Hope M. Baker

Kennesaw State  
University

Joanna R. Baker

University of North  
Carolina - Charlotte

Arthur G. Bedeian

Louisiana State  
University

William B. Carper

University of West  
Florida

James M. Clapper

Belmont University

Edward Clayton

Virginia Tech

Roscoe Davis

University of Georgia

Carl W. Gooding

Jacksonville State  
University

Sang M. Lee

University of  
Nebraska - Lincoln

George Lowry

Randolph-Macon  
College

Ina Markham

James Madison  
University

Laurence J. Moore

Virginia Tech

James A. Pope

University of Toledo

Terry R. Rakes

Virginia Tech

Stephanie S. Robbins

University of North  
Carolina - Charlotte

L. Drew Rosen

University of North  
Carolina - Wilmington

Brooke A. Saladin

Wake Forest University

Bernard W. Taylor III

Virginia Tech

Joseph G. Van Matre

University of Alabama -  
Birmingham

Betty Whitten

University of Georgia

A. James Wynne

Virginia Commonwealth  
University

Mary Sue Younger

University of Tennessee

Ronald Zigli

The Citadel



## Program Committee

### Program Chair

Ping Wang..... James Madison University

### Associate Program Chair

Luis Novoa..... James Madison University

### Local Arrangements Coordinator

L. Drew Rosen ..... University of North Carolina Wilmington

### Placement/Technology Coordinator

Jack Y. Lu ..... College of Charleston

### Proceedings Editor

Leigh A. Mutchler ..... James Madison University

### Track Chairs

Accounting, Economics, Cryptocurrency and Finance

Michelle Hagadorn ..... Roanoke College

Analytics, Big Data Applications, BI, Data Mining, Statistics and Expert Systems

Binshan Lin..... Louisiana State University at Shreveport

Data Analytics and Statistics Instruction (DASI) (Invited sessions only)

Robert Andrews ..... Virginia Commonwealth University

Kelli Keeling ..... University of Denver

Healthcare, Public Sector and Not for Profit Management

Elham Torabi ..... James Madison University

Helen You ..... James Madison University

Hospitality, Recreation and Sports

David Shonk ..... James Madison University

Information Privacy, Security and System Resilience Business Ethics and Business Law

Elena Olson..... Virginia Commonwealth University

Innovative Education, Assessment, Engaged Learning Curriculum, Teaching and Pedagogy

Ajay Aggarwal ..... Henderson State University

IS, IT, Blockchain Technology and Social Media

June Wei..... University of West Florida

Management, Strategy, Org. Behavior, Org. Theory and Human Resource Management

Sara Kiser ..... Alabama State University

Marketing, Consumer Behavior, International Business

Rebecca Scott..... University of North Carolina Wilmington

Student Papers (Undergraduate, Master and Ph.D Students)

Elizabeth Rasnick..... Georgia Southern University

Sustainability, SCM, Quality Management and Logistics

Hadi Farhangi..... Savannah State University

Suman Niranjana ..... University of North Texas





## Reviewers

Tope Adeyemi-Bello	East Carolina University
Murat Adivar	Fayetteville State University
Ajay Aggarwal	Henderson State University
Taiwo Amoo	Brooklyn College, City University of New York
Ozgun Araz	University of Nebraska
Richard Barnes	North Carolina State University
Kameleddine Benameur	Gulf University for Science and Technology
Lisa Burke-Smalley	University of Tennessee at Chattanooga
Christie Chen	University of Tennessee at Martin
Amita Chin	Virginia Commonwealth University
Cody Logan Chullen	East Carolina University
Scott Dellana	East Carolina University
Tom Dillon	James Madison University
Tom Downen	University of North Carolina Wilmington
MichaelENZ	Roanoke College
Hazel Fallas	Mixed Institute of Social Assistance
Hadi Farhangi	Savannah State University
Komlan Gbongli	University of Miskolc
Marko Grunhagen	Eastern Illinois University
John (Chengqi) Guo	James Madison University
Gary Hackbarth	Valdosta State University
Mohsin Hafsa	
Clint Harshaw	Presbyterian College
Robert Hasbrouck	Christopher Newport University
Janel Haynes	Alabama State University
James Jewett	James Madison University
Kimberly Johnson	Auburn University at Montgomery
Elizabeth Jones	Western Carolina University
Tugba Karabulut	Istanbul Commerce University
Joseph Kasten	Penn State
Mary Kiker	Auburn University at Montgomery
Brenda Killingsworth	East Carolina University
Ruth C. King	Fayetteville State University
Sara Kiser	Alabama State University
Jeong Kiyoun	University of Houston Clear Lake
Matthew Kolakowski	Valdosta State University
Inessa Korovyakovskaya	Savannah State University
James Lawler	Pace University
Yuan Li	University of Tennessee
Jian Lin	University of Houston Clear Lake
Philip Little	Coastal Carolina University
Shawn Lough	James Madison University
George Lowry	Randolph-Macon College
Kenneth MacLeod	East Carolina University



Joseph G Van Matre ..... University of Alabama at Birmingham  
Christina McCart..... Roanoke College  
Marjorie McInerney..... Marshall University  
Suman Niranjana ..... University of North Texas  
Quinton Nottingham ..... Virginia Tech  
Elena Olson Olson ..... Virginia Commonwealth University  
John O'Malley ..... Georgia Southern University  
Joshua Pate ..... James Madison University  
Elena Popel ..... Virginia Commonwealth University  
Tammy Prater..... Alabama State University  
Zhaoqiong Qin ..... Savannah State University  
Abolfazl Saghafi..... University of the Sciences  
Mikihiro Sato..... James Madison University  
Edie Schmidt ..... Nova Southeastern University  
Susan Shurden..... Lander University  
Suzie Smith ..... Presbyterian College  
M. Clint Taylor ..... University of Tennessee at Martin  
Hasan Uvet..... Georgia Gwinnett College  
Baback Vaziri ..... James Madison University  
Ping Wang ..... James Madison University  
Li Xun ..... Nicholls State University  
Helen You ..... James Madison University  
Mario Zaino..... Alabama State University  
Hao Zhang ..... James Madison University  
Cathy Ying Zheng..... Bryant University





**Accounting, Economics,  
Cryptocurrency and  
Finance - Abstracts**

# A STUDY OF THE DETERMINANTS OF SOCIAL RESPONSIBILITY DISCLOSURE QUALITY: EVIDENCE FROM KUWAITI LISTED COMPANIES

---

Oral

---

***Dr . Kameleddine Benameur*** <sup>1</sup>

*1. Gulf University for Science and Technology*

The purpose of this paper is to examine the impact of various factors on the quality of social responsibility disclosure. Combining multi-theories in a unique framework, it focuses on factors related to the strategy and vision of the firm (Social responsibility audit, presence of a social responsibility committee), diversity of and within boards (independence of the board, gender diversity) and factors related to the environment (social responsibility performance, degree of pollution of the company).

This study involves an attempt to develop a self-constructed index to measure social responsibility disclosure quality using qualitative attributes as provided by IASB and GRI frameworks and following (Chauvey e. A number of econometric techniques are used including panel data specifications using a sample of Kuwaiti listed companies in KSE for the period 2015-2019.

The study found that quality of disclosure remains relatively low. In addition, the findings indicate that a company's strategy and vision (social responsibility audit), diversity in boards (gender diversity) and social responsibility performance play significant roles in explaining variations in quality of social responsibility disclosure. This paper sheds light on whether various factors could affect the credibility of disclosed information using a multi theory framework. Standards setters and policy makers are recommended to think about implementing a generally accepted framework of non-financial reporting to answer the demand for more transparency and accountability.

This paper fills the gap in the literature by highlighting unexplored area of literature related to the quality of non-financial reporting drawing upon the regulatory framework of financial reporting.

# BENCHMARKING THE PERFORMANCE OF ASSET MANAGEMENT BANKS

---

Regular Session

---

***Dr . Davinder Malhotra <sup>1</sup>, Dr . Rashmi Malhotra <sup>2</sup>, Dr . Robert Nydick <sup>3</sup>***

*1. Thomas Jefferson University , 2. Saint Joseph's University , 3. Villanova University*

As the aging baby boomer generation saves for retirement and demands suitable retirement savings vehicles, the role of asset management banks is growing and the assets under their management are rising. We used a data envelopment analysis (DEA) model to evaluate the performance of 18 asset management banks for the 2018. We benchmark the performance of asset management banks on the basis of return on assets (ROA), earnings before interest, taxes, depreciation, revenue per employee, and amortization (EBITDA) margin, effective tax rate, and capital intensity. We find that only 4 banks out of 18 are 100% efficient relative to their peers, 3 banks are more than 95% efficient relative to their peers. Data envelopment analysis clearly brings out the firms that are operating more efficiently in comparison to other firms in the industry, and points out the areas in which poorly performing firms need to improve.

# BUSINESS CLIMATE AND GROWTH NEXUS: EVIDENCES FROM PANEL CO-INTEGRATION, DYNAMIC OLS, GMM, VEC ESTIMATES ANALYSIS

---

Oral

---

*Dr . Muhammad Mustafa<sup>1</sup>, Dr . Haile Selassie<sup>1</sup>*

*1. South Carolina State University*

This paper investigates dynamic short-run and long-run linkages among business climate variables such as capital investment, wage, education and economic growth. Panel Cointegration, dynamic OLS, GMM, ECM and Dumitrescu Panel Causality test are applied, The panel cointegration tests, dynamic OLS estimates show long-run equilibrium relationship among the variables. The panel Dynamic OLS estimates indicate capital investment, wage and education have significant positive, while poverty and death rate have significant negative effect on economic growth. GMM findings are similar except that they are short-run linkages on economic growth. The estimates of ECM reveal statistically significant convergence toward long-run equilibrium with mixed short-run interactive feedback effects. Finally, Dumitrescu Hurlin panel causality tests indicate that there is bidirectional causality between wage, capital investment, and economic growth, capital investment and education, wage and education, poverty and wage, and poverty rate and education. Policy implication is that to increase economic the policy makers should promote, education, capital investment, and wage and reduce poverty rate and death rate.

**Key Words:** Growth, Capital Investment, Wage, Poverty rate, Death Rate, Education, Dynamic OLS, GMM, ECM, Dumitrescu Causality

JEL Classification: O10, O20, O21

---

# CDS Premiums, Bond Yields and Stock Returns: Causality, Co-movement and Price Discovery

---

Oral

---

***Mr . Yi Lu <sup>1</sup>, Dr . David Kemme <sup>1</sup>, Dr . Jacob Kleinow <sup>2</sup>, Dr . Benjamin Aust <sup>2</sup>***

*1. University of Memphis , 2. Freiberg University*

We investigate the causal relationship between credit-default swap (CDS), bond and stock markets. In a panel time-series framework for preliminary analysis, we use daily data of 96 corporations from the North America and Europe trading on the NYSE during the period from 2005 to 2013. The daily EURO five-year overnight index swap rate is the reference rate to calculate the CDS and bond spreads. These spreads are the risk premiums associated with corporations' risky instruments. Theoretically, the risk premiums captured by CDS and bond yield should be equal. However, data reveal a significant difference between the two spreads.

We first explore the causal relationship between CDS, bond and stock markets' short-run movements with Vector Auto Regression (VAR) model. The VAR model examines how shocks from one market impacts the other in terms of Granger causality when the variables are stationary, and not cointegrated. Then second, we estimate the long-run cointegrating relationship between the CDS market and bond market with firm-level Vector Error Correction (VECM) model. The VECM model examines how these markets adjust to each other regarding speed of adjustment from error correction terms when the variables are cointegrated.

In addition, the price-discovery process is estimated and employed to forecast the dynamics of the two markets. In this paper, we extend the Gonzalo and Granger price-discovery analysis using rolling windows technic to estimate a time-variant price-discovery metric in the two markets. In conclusion, there is a leading position for CDS premiums over bond spreads in the price-discovery process, but we also can observe some fluctuations that bond market takes the leading position around specific dates.



# Does Using Artificial Intelligence in an Audit Reduce Auditor's Liability?

---

Oral

---

*Dr . Sarah Kim <sup>1</sup>, Dr . Tom Downen <sup>2</sup>*

*1. National Cheng Kung University , 2. University of North Carolina Wilmington*

Big-4 firms have begun making extensive investments in developing audit programs based on artificial intelligence (AI). However, the legal implications of using AI in the case of an audit failure are not heavily explored. In this study, we investigate whether and how using AI to partially complete an audit, compared to having human auditors complete the same work, may affect auditor negligence verdicts by jurors in case of an audit failure. We also investigate whether and how the work being outsourced or insourced interacts with the use of AI. The similarity-leniency hypothesis posits that the more a juror associates with the defendant, the more lenient the juror evaluation will be. However, this leniency depends upon the proximity of the wrongdoing to the defendant and/or the intensity of the wrongdoing, referred to as the “black-sheep effect”. Consistent with the similarity-leniency hypothesis, we find that, in an audit in which the misjudgment is attributable to human staff (rather than AI), jurors evaluate characteristics of the defendant more favorably and, subsequently, attribute the reasons for the audit failure for more circumstantial rather than personal reasons. Consequently, jurors assess more lenient verdicts. However, consistent with the black-sheep effect, the leniency is evident only when the work is outsourced (perceived to be less controllable by the audit firm) but not when it is insourced (more controllable by the audit firm).

# Impact of Tax Reform on In-Place Child Custody Orders That Rely Upon Exemptions

---

Oral

---

***Dr. Richard Barnes*** <sup>1</sup>

*1. Western Governors University*

This article is an early-stage working paper examining the impact of tax reform on the ability of divorced or separated parents to claim children on their tax returns under existing exemption-focused family court orders. The article uses a legal research methodology to analyze changes to the dependency exemption during tax reform. The article debunks the common notion in accounting practice circles that tax reform ‘repealed’ exemptions and clarifies that tax reform merely eliminated the dollar value of exemptions as they were formerly used in the tax system. The underlying traceability of exemptions to multiple other tax benefits remains intact despite that exemptions themselves no longer have monetary value.

# Maternal and Infant Outcomes in the United States

---

Oral

---

Ms . Tyler Davis <sup>1</sup>, Dr . Johnathan Munn <sup>1</sup>, Dr . Caroliniana Padgett <sup>1</sup>

*1. Francis Marion University*

Maternal and infant outcomes in childbirth continue to steadily improve around the world, including in the United States. Advances in medicine and increased access to healthcare have aided in these improvements at the national level. Relevant literature has cited factors directly correlated with improved outcomes, such as education, income, and access to care. However, there are still large discrepancies in outcomes between mothers and infants residing in urban areas versus rural areas. These discrepancies are particularly large in the United States, where significant differences in infant and maternal outcomes are rising across different geographic areas. Using micro level data from the National Center for Health Statistics, this study aims to investigate whether the factors cited as improving outcomes for both mothers and infants have the same effects for urban and rural mothers and infants. For example, does education improve outcomes in a similar manner for mothers and infants residing in rural areas as it does for mothers and infants living in urban areas? The data provide individual birth statistics for all births from 2008-2018 in the United States. Our model allows us to compare whether factors like education provide the same benefit to all mothers. This provides important policy making information for improving health outcomes across all segments of the United States population. Inconsistencies in how these factors affect each population allows policymakers to decide how to best allocate funding that will increase equality in infant and maternal outcomes across all geographic areas. This is particularly important as the cost structure of healthcare systems continue to shift.

# PROFILING THE DOTCOM BUBBLE AS A PREDICTOR OF TESLA'S FUTURE

---

Oral

---

*Ms . Jasnoor Kaur*<sup>1</sup>, *Prof . Jack Trifts*<sup>2</sup>, *Prof . Cathy Ying Zheng*<sup>1</sup>

*1. Bryant University , 2. Bryant Uni*

The late 1990s, commonly referred to as the “DotCom Bubble”, exhibited optimistic growth for the thriving technology industry. Companies began filing for bankruptcy, bringing this growth to a rapid halt. After surviving the boom and bust of this era, could firms use this as a learning experience in an effort to prevent such failures in the future? Furthermore, could profiling these financial failures be used to predict the future of Tesla, a thriving innovative enterprise? Utilizing relevant data from Compustat and CRSP, a combined data set was created and filtered for the appropriate industries. A logit model of seven control variables was applied to help predict failure for Tesla and like firms. Of the seven variables, four appeared to be major driving factors in predicting bankruptcy. These variables include: profitability, leverage, volatility, and relative size for the firms in the sample period. The findings suggest that bankrupt firms have a lower mean profitability, greater leverage, lower liquidity, lower excess returns, and less cash flow from operations. Tesla has tight cash flow, lower current profitability, but is highly valued by investors, suggesting that investors still believe that the company has a future. The results indicate that Tesla Motors Incorporated has a 1.17% probability for filing for either Chapter 7 or Chapter 11 bankruptcy in the next quarter. Moreover, it has a 0.76% likelihood for default in the upcoming four quarters. These are much lower than the bankruptcy rate of 2.47% for firms of the DotCom Bubble. These findings can be applied to better understand the future for Tesla Inc., and similar firms, that exhibit trends like those in this study. Furthermore, they can be used in creating a plan to help prevent bankruptcy for the firms, increasing success.

# **Sarbanes-Oxley Act Section 302 Technology Issues and Auditor Effort**

---

Regular Session

---

***Dr . Anna Johnson-Synder <sup>1</sup>, Dr . Brenda Killingsworth <sup>1</sup>***

*1. East Carolina University*

Changes in auditing standards have resulted in fluctuations in audit fees since the inception of the Sarbanes-Oxley (SOX) Act of 2002. Clients want a decrease in audit fee; however, a decrease in audit effort may not be likely as more entities delve deeper into the use of automation and technology, which also leads to a higher risk of having technology issues or cyber breaches. The purpose of this study is to examine the impact of SOX Section 302 No. 22, Technology Issues on audit effort.

# Technology innovation and health care in Israel: the effect of international cooperation patents on healthcare expenditures

---

Oral

---

*Dr . Helen You <sup>1</sup>, Dr . Albert Okunade <sup>2</sup>*

*1. James Madison University , 2. The University of Memphis*

Israel has been ranked as the top healthiest country in the world for years, with high standards of health services, high-quality medical research, and a high ratio of physicians. Meanwhile, high-tech services contribute significant and immediate improvements in the quality and safety of health care. Israel takes advantage of a lucrative “health technology tsunami”, creates partnerships with European and US, gain a global competitive edge via innovation, and Israeli innovation goes global via the partnership cooperation. This study specifies and econometrically estimates the Autoregressive Distributed Lag Cointegration (ARDL) model of health care expenditures in Israel, using the 1980-2017 time-series data, with income (GDP) and technology (International Cooperation patents) are the two major drivers, along with the age dependency ratio and physicians. ARDL bounds test for cointegration and Granger causality test for the causal link are applied. Empirical results suggest that there is a long-run relationship among the healthcare expenditures, patents, physician, and aging ratio. The increase of international cooperation patents is positively affecting the growth rate of the healthcare expenditures (HCE), however, the effect of patents from residences on HCE is negative; while the effects are fluctuating from year to year as patents could conceivably reduce the health spending if new patented medical products turn out to be cheaper than existing interventions. As always, income (GDP) is the main driver of the growth of health care expenditures, as well as the impressive ratio of physicians and the significantly higher effect of aging ratio.

# TESTING FOR AN ASYMMETRIC RELATIONSHIP BETWEEN INFLATION AND ITS VOLATILITY

---

Oral

---

*Dr . Barry Pfitzner <sup>1</sup>*

*1. Randolph-Macon College*

This paper investigates the behavior of inflation, measured by the Consumer Price Index and the Personal Consumption Expenditure Index with primary focus on the relationship between inflation and its volatility. Over the past 70 years, the inflation rate has shown periods of tranquility as well as periods of volatility. Evidence from the early 2000s suggests that inflation, after a period tranquility during the 1990s, became more volatile early in the new century (perhaps even as early as 1999)—prior to the run-up in the energy and food sectors. Since the 2008-2009 rise in volatility, inflation has entered a more tranquil phase, but is still more volatile than during the Great Moderation of the 1990s. Relatively new research has suggested that the relationship between inflation and its volatility is not monotonic—that is, (very) low inflation rates may also be more volatile. This research supports an asymmetric relationship between inflation volatility and the level of inflation. Based on two measures of inflation, very low inflation rates are accompanied by higher volatility, and inflation rates above some threshold (approximately 3.5%) also produce greater volatility.

# Will Oil Go Up or Down Next Week: A Decision Tree Investigation

---

Oral

---

*Dr . Mary Malliaris <sup>1</sup>, Dr . Anastasios Malliaris <sup>1</sup>*

*1. Loyola University Chicago*

In this paper, we focus on understanding the directional movement of the spot price of oil from one week to the next. This paper uses seven variables, each in two forms, to model the direction that oil will move. A C5.0 Decision Tree is constructed using these variables as inputs and develops rules that pattern next week's oil direction correctly about 87% of the time. Some input variables used were related to oil and include net imports, days of supply, amount of product supplied, and oil production. The remaining three variables are financial and include the price of copper, the trade-weighted dollar, and a high-yield spread. The data set ranges from January 1997 to early October 2019.



# **Accounting, Economics, Cryptocurrency and Finance - Papers**

## A STUDY OF THE DETERMINANTS OF SOCIAL RESPONSIBILITY DISCLOSURE QUALITY: EVIDENCE FROM KUWAITI LISTED COMPANIES

Kameleddine Benameur

Gulf University for Science and Technology

### Abstract

The purpose of this paper is to examine the impact of various factors on the quality of social responsibility disclosure. Combining multi-theories in a unique framework, it focuses on factors related to the strategy and vision of the firm (Social responsibility audit, presence of a social responsibility committee), diversity of and within boards (independence of the board, gender diversity) and factors related to the environment (social responsibility performance, degree of pollution of the company).

This study involves an attempt to develop a self-constructed index to measure social responsibility disclosure quality using qualitative attributes as provided by IASB and GRI frameworks and following (Chauvey et al., 2015). A number of econometric techniques are used including panel data specifications using a sample of Kuwaiti listed companies in KSE for the period 2015-2019.

The study found that quality of disclosure remains relatively low. In addition, the findings indicate that a company's strategy and vision (social responsibility audit), diversity in boards (gender diversity) and social responsibility performance play significant roles in explaining variations in quality of social responsibility disclosure.

This paper sheds light on whether various factors could affect the credibility of disclosed information using a multi theory framework. Standards setters and policy makers are recommended to think about implementing a generally accepted framework of non-financial reporting to answer the demand for more transparency and accountability.

This paper fills the gap in the literature by highlighting unexplored area of literature related to the quality of non-financial reporting drawing upon the regulatory framework of financial reporting.

*Keywords:* Social responsibility disclosure; disclosure quality; strategy and vision, diversity, social responsibility performance, Kuwait

## **EVALUATING THE PERFORMANCE PERSISTENCE OF ASSET MANAGEMENT BANKS USING DATA ENVELOPMENT ANALYSIS**

D.K. Malhotra, School of Business Administration, Thomas Jefferson University, School  
House Lane & Henry Avenue, Philadelphia, PA 19144, 215-951-2813,  
[Davinder.Malhotra@Jefferson.edu](mailto:Davinder.Malhotra@Jefferson.edu)

Rashmi Malhotra, Haub School of Business, Saint Joseph's University, 5600 City Avenue,  
Philadelphia, PA 19131, 610-660-3497, [rmalhotr@sju.edu](mailto:rmalhotr@sju.edu)

### **ABSTRACT**

As the aging baby boomer generation saves for retirement and demands suitable retirement savings vehicles, the role of asset management banks is growing and the assets under their management are rising. We used a data envelopment analysis (DEA) model to evaluate the performance of 18 asset management banks for the 2018. We benchmark the performance of asset management banks on the basis of return on assets (ROA), earnings before interest, taxes, depreciation, revenue per employee, and amortization (EBITDA) margin, effective tax rate, and capital intensity. We find that only 4 banks out of 18 are 100% efficient relative to their peers, 3 banks are more than 95% efficient relative to their peers. Data envelopment analysis clearly brings out the firms that are operating more efficiently in comparison to other firms in the industry, and points out the areas in which poorly performing firms need to improve.

### **INTRODUCTION**

The asset management banks are part of the capital markets industry and include mutual funds, closed-end funds, unit investment trusts, investment counseling firms, and other groups that manage the pooled savings of individuals or organizations. Asset management banks are one of the two primary sub-industries within the capital markets industry and account for more than 57 percent of the capital markets industry in terms of market capitalization (Source: S&P Capital IQ Industry Surveys: Capital Markets, 2018). According to Investment Company Institute (ICI), the asset management industry will likely continue to see substantial growth over the next couple of decades as the aging baby boomer generation (approximately 77 million Americans born between 1946 and 1964) saves for retirement and demands more suitable retirement savings vehicles.

Asset management companies compete for the business of potential investors by offering them various types of investment products that match investor's risk-return profile at a reduced cost. Because larger size enables firms to reduce costs to potential investors, size has increasingly become a source of competitive advantage for the asset management industry. At the same time, as global capital markets have expanded again in the aftermath of economic crisis of 2008-2009, regulatory oversight that increases capital requirements for liquidity to prevent a repeat of the previous financial crisis has also given larger firms an advantage. Compared to smaller firms, larger firms are better positioned and equipped to

take advantage of the growing market by leveraging their global scale and market share, in terms of higher revenue, because assets are the resources that firms use to generate revenue. Meanwhile, the asset management industry is going through structural changes with the growing importance of algorithmic trading, artificial intelligence based portfolio trading, technological innovations, and back office automation that is causing a decline in fees and expense ratios.

Investment companies managed 9356 mutual funds in the United States as of December 2017, with \$18.3 trillion in assets under management, up from \$11.8 trillion at the end of 2010, according to the Investment Company Institute (ICI). Although the dollar amount of assets managed by asset management industry has increased several-fold, to our knowledge, no empirical research exists that evaluates the performance of asset management banks. In this paper, we illustrate the use of data envelopment analysis, an operations research technique, to analyze performance of asset management banks by benchmarking an asset management bank against its peers to understand the relative performance of a bank. Data envelopment analysis clearly brings out the firms that are operating more efficiently in comparison to other firms in the industry. Data envelopment analysis also points out the areas in which poorly performing firms need to improve.

The rest of the paper is organized as follows: Section II reviews previous studies that illustrate how the data envelopment analysis model has been applied in the banking industry; Section III discusses the methodology used; Section IV describes the data envelopment analysis model; Section V provides an empirical analysis of our results; and Section VI summarizes and concludes our study.

### **THE DATA ENVELOPMENT ANALYSIS MODEL**

The Data Envelopment Analysis (DEA) (Charnes et al., 1978) is a generalized optimization technique that measures the relative performance of different decision making entities having multiple objectives (outputs) and multiple inputs structure. The DEA methodology measures the relative performance of the entities/organization units called Decision-Making Units (DMUs). This technique measures the efficiency with which a DMU uses the resources available (inputs) to generate a given set of outputs. The DEA methodology assesses the performance of the DMU using the concept of efficiency or productivity, defined as a ratio of total outputs to total inputs. Further, the DEA estimates relative efficiency. The DEA allocates the efficiency of a DMU relative to the best performing DMU or DMUs (in case multiple DMUs are most efficient). In addition, the DEA allocates an efficiency score of unity or 100 percent to the most efficient unit, and the low-performing DMUs efficiency can vary between 0 and 100 percent in comparison to the best performance.

Data envelopment analysis is a technique used to assess the productive efficiency of homogenous operating units such as schools, hospitals, banks, or utility companies. It is a powerful technique for measuring performance because of its objectivity and ability to handle multiple inputs and outputs that can be measured in different units. The DEA approach does not require specification of any functional relationship between inputs and

outputs or a priori specification of weights of inputs and outputs. DEA provides gross efficiency scores based on the effect of controllable and uncontrollable factors. Figure 1 illustrates a decision support system using data envelopment analysis. DEA uses a number of ratios to determine how good an asset management bank's performance has been. The ratios that need to be maximized serve as outputs and ratios that need to be minimized serve as inputs. Using this information, the approach does not require specification of any functional relationship between inputs and outputs or a priori specification of weights of inputs and outputs. DEA provides gross efficiency scores based on the effect of controllable and uncontrollable factors. With these financial ratios as inputs, the DEA-based decision support system calculates an efficiency score for a firm. This score is a relative value computed by comparing the given firm to a pool of well-performing companies that serve as a benchmark for the company under evaluation. Each firm is evaluated against either an existing firm or a hypothetical firm with an identical set of inputs or outputs that is constructed as a combination of good performing companies.

By using the existing good companies as a "role model," DEA not only helps differentiate well performing (efficient companies from poorly performing (inefficient) firms, but also brings out the reasons why a company may be underperforming. This helps investors and creditors justify their decisions to invest or not to invest their funds in a particular company. This will also help management identify areas of weakness for a firm so that management plans can focus on plugging the weaknesses or taking steps to counter the weaknesses.

Traditional financial statement analysis techniques use ratio analysis to compare a firm's performance against its peers in the industry as well as against the company's historical performance. On the basis of this comparison, analyst will recommend whether the company is doing well or underperforming relative to its peers or relative to its own past performance. DEA employs relative efficiency, a concept enabling comparison of companies with a pool of known efficient companies. The DEA model compares a firm with the pool of efficient companies by creating an efficiency frontier of good firms—a tolerance boundary created by establishing the efficiency of firms in terms of several sets of financial ratios. Companies lying beyond this boundary can improve one of the input values without worsening the others. The higher the return on equity or return on assets or interest coverage or return or asset turnover ratio, the higher the chances of a firm turning out to be efficient. Similarly, the higher the leverage ratio or total debt to total capital ratios, the higher the chances that the firm will turn out to be bad. The acceptance boundary has firms that are considered to be 100% efficient.

### **DATA AND MODEL**

We used the financial statement data available from Mergent Online for this study. We used six ratios to evaluate eighteen asset management banks from the capital markets industry. A list of the eighteen asset management banks is provided in appendix. These asset management banks have been identified as competitors by Standard & Poor's Industry Surveys for capital markets industry. Table 2 illustrates the pooled data of the eighteen companies used for analysis.

### **Data Envelopment Model Specifications for the Asset Management Industry**

Besides the mathematical and computational requirements of the DEA model, there are many other factors that affect the specifications of the DEA model. These factors relate to the choice of the DMUs for a given DEA application, selection of inputs and outputs, choice of a particular DEA model (e.g. CRS, VRS, etc.) for a given application, and choice of an appropriate sensitivity analysis procedure (Ramanathan, 2003). Due to DEA's non parametric nature, there is no clear specification search strategy. However, the results of the analysis depend on the inputs/outputs included in the DEA model. There are two main factors that influence the selection of DMUs – homogeneity and the number of DMUs. To successfully apply the DEA methodology, we should consider homogenous units that perform similar tasks, and accomplish similar objectives. In our study, the companies are homogenous as they are identified by S&P Industry Surveys on capital markets to be competitors. Furthermore, the number of DMUs is also an important consideration. In addition, the number of DMUs should be reasonable so as to capture high performance units, and sharply identify the relation between inputs and outputs. The selection of input and output variables is the most important aspect of performance analysis using DEA. In general, the inputs should reflect the level of resources used or a factor that should be minimized. The outputs reflect the level of the economic variable factor, and the degree to which an economic variable contributes to the overall strength (efficiency) of a company. There are some simple rules of thumb that guide the selection of inputs and outputs, and the number of participating DMUs.

To study the performance of the asset management industry, we consider six factors to develop the DEA model: return on assets, earnings before interest, taxes, depreciation, and amortization (EBITDA) margin, interest coverage ratio, revenue per employee, effective tax rate, and capital intensity ratio. Out of these six factors, we specify effective tax rate and capital intensity ratio as input, because for a given company the lower these variables are the better the performance of the company. Similarly, : return on assets, earnings before interest, taxes, depreciation, and amortization (EBITDA) margin, interest coverage ratio, revenue per employee imply a better-performing company. Thus, we consider these variables as output variables. Finally, the choice of the DEA model is also an important consideration. We should select the appropriate DEA model with options such as input maximizing or output minimizing, multiplier or envelopment, and constant or variable returns to scale. DEA applications that involve inflexible inputs or not fully under control inputs should use output-based formulations. On the contrary, for an application with outputs that are an outcome of managerial goals, input-based DEA formulations are more appropriate. In addition, for an application that emphasizes inputs and outputs, we should use the multiplier version. Similarly, for an application that considers relations among DMUs, envelopment models are more suitable. Furthermore, the characteristics of the application dictate the use of constant or variable returns to scale. If the performance of DMUs depends heavily on the scale of operation, constant returns to scale (CRS) is more applicable, otherwise variable returns to scale is a more appropriate assumption.

In our study, the comparative evaluation among the companies is an important consideration. Therefore, we select the envelopment models for our analysis. In addition, the outputs are an outcome of managerial goals. Therefore, input-based formulation is recommended for our study. The objective of the analysis is to suggest a benchmark for the asset management banks. Furthermore, to investigate the effect of scale of operations, if any, among the 18 companies, we consider both variable returns to scale and constant returns to scale DEA models. Also, the structure of the DEA model (in envelopment form) uses an equation and separate calculation for every input and output. Therefore, all the input and output variables can be used simultaneously and measured in their own units. In this study, we use the Input-Oriented Variables Return to Scale (VRS) to evaluate the efficiency of 18 asset management banks for the year 2018.

Figure 1 illustrates a decision support system using data envelopment analysis. The decision support system uses the DEA methodology to assess the performance of each company. The DEA-based decision support system uses the company attributes –effective tax rate and capital intensity ratio as input variables. The system uses the return on assets, earnings before interest, taxes, depreciation, and amortization (EBITDA) margin, interest coverage ratio, revenue per employee as output variables to calculate an efficiency score for a firm. This score is a relative value computed by comparing the given firm to a pool of well-performing companies that serve as a benchmark for the company under evaluation. Each firm is evaluated against the existing firms with an identical set of inputs or outputs that is constructed as a combination of performing and non performing companies. By using the existing good companies as a “role model,” DEA not only helps differentiate well performing (efficient companies from poorly performing (inefficient) firms, but also brings out the reasons why a company may be underperforming. This helps investors and creditors justify their decisions to invest or not to invest their funds in a particular company. This will also help management identify areas of weakness for a firm so that management plans can focus on plugging the weaknesses or taking steps to counter the weaknesses.

### **EMPIRICAL ANALYSIS**

Each of the asset management banks is a homogenous unit, and we can apply the DEA methodology to assess a comparative performance of these companies. Using the DEA methodology, we can calculate an efficiency score for the 18 banks on a scale of 1 to 100. We analyze and compute the efficiency of these banks using the ratios for the year end 2018. Table 3 illustrates the efficiency scores for 18 companies. Further, we also study the peers (model companies) for inefficient companies. Table 3 shows the relative performance of the asset management banks benchmarked against each other. As shown in Table 3, there are only four asset management banks that are 100% efficient relative to their peers in 2018. Blucoare, Inc., (BLCOR), Blackstone Group (BX), Cohen & Steers (CNS), and T. Rowe Price Group, Inc. (TROW) are 100% efficient relative to other asset management banks for the year 2018. In addition, SEI Investments Company (SEIC) and Waddell & Reed Financial, Inc. (WDR) are 99% efficient relative to their peers, while Federated Investors, Inc. (FII) is 95% efficient relative to their peers. Out of 18 asset management banks in the sample, 11 banks are inefficient relative to their peers when evaluated on the basis of ROA, EBITDA margin,

revenue per employee, effective tax rate, interest coverage ratio, and capital intensity ratio. Affiliated Managers Group Inc. (NYS: AMG), Ameriprise Financial Inc. (NYS: AMP), Franklin Resources Inc. (NYS: BEN), BlackRock Inc. (NYS: BLK), the Blackstone Group Inc., Calamos Asset Management Inc. (NMS: CLMS) Cohen & Steers, Inc., Eaton Vance Corporation, Federated Investors Inc. (PA) (NYS: FII), Invesco Ltd (NYS: IVZ), Legg Mason, Inc. (NYS: LM), T Rowe Price Group Inc. (NMS: TROW), Virtus Investment Partners Inc. (NMS: VRTS), SEI Investments Co (NMS: SEIC) Waddell & Reed Financial, Inc. (NYS: WDR), WisdomTree Investments, Inc. (NMS: WETF) Janus Henderson Group Plc (NYS: JHG) are significantly less than 100% efficient relative to their peers. The least efficient asset management bank is AMP with an efficiency score of only 17% relative to its peers, followed by BLK and IVZ with a score of 28%, and VRTS with a score of 31%. Since, there is wide difference in efficiency scores of different asset management companies, it only goes to show that skill of management in managing your money matters, because some of them are simply significantly more efficient relative to others.

Figure 2 shows the efficiency frontier graph of the pooled company data. The 100% efficient companies (blue dots) are on the efficiency frontier, whereas the inefficient companies (red dots) are inside the efficiency frontier. The DEA Analyzer calculates the level of inefficiency by measuring the distance between the efficiency frontier and the inefficient companies. Therefore, a financial analyst can use this efficiency frontier to assess the relative efficiency of the firm in the industry. The DEA model compares the return on assets (ROA), earnings before interest, taxes, depreciation, revenue per employee, and amortization (EBITDA) margin, effective tax rate, and capital intensity. The efficiency scores are shown in percentage value varying between 0% and 100%. We find that the efficiency of BLCOR, BX, CLMS, and TROW is 100% and they are on the efficiency frontier. In addition, SEIC (99%), WDR (99%), and FII (95%) are almost near the efficiency frontier. On the other hand, the input efficiency of the remaining companies is: AMG (57%), AMP (17%), BEN (46%), BLK (28%), CLMS (65%), EV (70%), IVZ (28%), LM (40%), VRTS (31%), WETF (64%), and JHG (51%) are all below the efficient frontier.

Table 4 illustrates the efficiency scores and the corresponding ranking of the pooled asset management banks in the year 2018. The average score is 66%, with eight companies having efficiency levels above average, while the remaining ten are below the average level. The four 100% efficient companies turned out to be the best practices companies within the pooled database of the Decision Support System. As AMG (57%), AMP (17%), BEN (46%), BLK (28%), CLMS (65%), EV (70%), IVZ (28%), LM (40%), VRTS (31%), WETF (64%), and JHG (51%) are inefficient, the next step is to identify the efficient peer group or companies whose operating practices can serve as a benchmark to improve the performance of these companies. Table 5 illustrates the peer group for the inefficient companies. As shown in Table 5, BLCOR, BX, CNS, and TROW serve as peers for inefficient companies. BLCOR is the peer 14 companies. BLCOR is the largest peer for AMP (0.89), CLMS (0.75), IVZ (0.76), VRTS (0.63), and JHG (0.51). BX is the largest peer for BLK (0.56) and relatively smaller peer for AMG (0.16), AMP (0.04), and WETF (0.04). CNS is the largest peer for BEN (0.90), EV (0.83), FII (0.84), LM (1.0), SEIC (0.91), WDR (0.89), and WETF (0.74) and relatively smaller peer for CLMS (0.23), IVZ (0.11), VRTS (0.37), and JHG (0.21). TROW is the largest peer for AMG



(0.51) and relatively smaller peer for AMP (0.07), BEN (0.10), BLK (0.05), CLMS (0.01), EV (0.01), FII (0.14), SEIC (0.7), WDR (0.07), and JHG (0.28). The efficient peer companies have a similar mix of input-output levels to that of the corresponding inefficient company, but at more absolute levels. The efficient companies generally have higher output levels relative to the company in question. The features of efficient peer companies make them very useful as role models that inefficient companies can emulate to improve their performance.

### **SUMMARY AND CONCLUSION**

Traditional financial statement analysis techniques use ratio analysis to compare a firm's performance against its peers in the industry as well as against the company's historical performance. On the basis of this comparison, analyst will recommend whether the company is doing well or underperforming relative to its peers or relative to its own past performance. Using DEA, a non-parametric, performance measurement technique that enables managers to perform efficiency analysis of investment management services, this study evaluated the relative efficiency of 18 asset management banks for the year 2018. DEA employs relative efficiency, a concept enabling comparison of companies with a pool of known efficient companies. The DEA model compares a firm with the pool of efficient companies by creating an efficiency frontier of good firms—a tolerance boundary created by establishing the efficiency of firms in terms of several sets of financial ratios. Companies lying beyond this boundary can improve one of the input values without worsening the others. We found that, out of 18 asset management banks, only 4 banks were 100% efficient and 3 banks scored 95% or more on the efficiency scorecard on the basis of return on assets, EBITDA margin, revenue per employee, effective tax rate, interest coverage ratio, and capital intensity. We also illustrated the areas in which inefficient companies are lagging behind efficient firms. The study also provides an insight into the benefits of DEA methodology in analyzing financial statements of firms. The decision support system stores the company's historical data, competitive firm's data, and other industry specific data, and uses the DEA methodology to analyze a firm's performance. Moreover, DEA modeling does not require prescription of the functional forms between inputs and outputs. DEA uses techniques such as mathematical programming that can handle a large number of variables and constraints. As DEA does not impose a limit on the number of input and output variables to be used in calculating the desired evaluation measures, it's easier for loan officers to deal with complex problems and other considerations they are likely to confront.

### **REFERENCES, TABLES, & FIGURES**

References, Tables, and Figures are available upon request.

---

**Does Using Artificial Intelligence in an Audit Reduce Auditor's Liability?**

---

**Sarah Kim**

*Associate Professor  
National Cheng Kung University  
sarahkintaiwan@gmail.com*

**Tom Downen**

*Associate Professor  
University of North Carolina Wilmington  
downent@uncw.edu*

**ABSTRACT**

Big-4 firms have begun making extensive investments in developing audit programs based on artificial intelligence (AI). However, the legal implications of using AI in the case of an audit failure are not heavily explored. In this study, we investigate whether and how using AI to partially complete an audit, compared to having human auditors complete the same work, may affect auditor negligence verdicts by jurors in case of an audit failure. We also investigate whether and how the work being outsourced or insourced interacts with the use of AI. The similarity-leniency hypothesis posits that the more a juror associates with the defendant, the more lenient the juror evaluation will be. However, this leniency depends upon the proximity of the wrongdoing to the defendant and/or the intensity of the wrongdoing, referred to as the “black-sheep effect”. Consistent with the similarity-leniency hypothesis, we find that, in an audit in which the misjudgment is attributable to human staff (rather than AI), jurors evaluate characteristics of the defendant more favorably and, subsequently, attribute the reasons for the audit failure for more circumstantial rather than personal reasons. Consequently, jurors assess more lenient verdicts. However, consistent with the black-sheep effect, the leniency is evident only when the work is outsourced (perceived to be less controllable by the audit firm) but not when it is insourced (more controllable by the audit firm).

---

**Does Using Artificial Intelligence in an Audit Reduce Auditor's Liability?**

---

**INTRODUCTION**

Artificial intelligence (AI) is experiencing increasing use in a wide variety of industries, including accounting and auditing. While there are many benefits of using AI, there are also risks associated with AI failures; and determining who is responsible in such circumstances is complicated. For example, there was an incident in 2018 in which an AI-enabled vehicle being operated for Uber malfunctioned and struck and killed a pedestrian (Wakabayashi 2018). Should the blame for this accident be assigned more to the driver who placed the vehicle in autonomous-driving mode, or to the company employing the AI (Uber), or perhaps even to the original designer of the AI-system? As companies in different industries consider more widespread use of AI, they need to understand what legal implications may arise in cases of AI failure.

Within the accounting industry, Big-4 firms have begun making extensive investments in developing AI-based audit systems (Zhou 2017). Outside technology firms have also begun developing AI-based audit software, targeting ready-made programs to the needs of accounting firms (Kokina and Davenport 2017). AI-based software has already been used in audit firms for purposes such as electronic data interchange, electronic file transfer (EFT), and image processing (Omoteso 2012), and it is expected to be used in audits across more functions and by more firms (Issa, Sun, and Vasarhelyi 2016). However, litigation implications of using AI in an audit has been scantily explored in the literature (Omoteso 2012). At the same time, there has been increasing use of outsourcing in audits (Daugherty and Dickins 2009), which can influence the risks and legal implications (Lyubimov, Arnold, and Sutton 2012). Increasing demand for AI-based audit software, combined with the increasing availability of externally-developed AI systems, introduces scenarios in which either insourced or outsourced AI could be used in an audit. With

few existing precedents, the litigation implications of using AI in an audit are difficult to predict, and it is further complicated in the case of outsourcing.

In this study, we investigate how using AI to partially complete an audit, compared to having human auditors complete the same work, may affect the negligence assessment and related verdicts by jurors in the case of an audit failure. We also investigate whether the work being outsourced or insourced interacts with the effect of using AI on the negligence verdicts by jurors. To explore these issues, we conduct a 2 (human staff or AI)  $\times$  2 (outsourcing or insourcing) between-participants experiment based on Grenier, Lowe, Reffett, and Warne (2015); however, we utilize facts adapted from an actual SEC case (SEC 2015) in which an accounting firm was accused of insufficient supervision of staff judgments. Based on the similarity-leniency hypothesis (Davis, Bray, and Holt 1977; Dane and Wrightsman 1982; Wrightsman 1987), we predict and find that jurors evaluate the audit firm more favorably and assess less frequent guilty verdicts when human staff (“similar others” to the juror) completes the work as compared to using AI. However, that more favorable assessment is contingent upon the work being outsourced (less controllable by the firm), consistent with the “black-sheep effect” (Marques, Yzerbyt, and Leyens 1988; Marques and Yzerbyt 1988; Kerr, Hymes, Anderson, and Weathers 1995). Importantly, we also show that the ultimate effect of the use of human staff (as compared to AI) on juror verdicts is because of the intervening influences of the characteristic assessment of the audit firm and the personal-level attribution for the audit failure; this addresses, in part, a call by Lyubimov, et al. (2012) for research addressing the underlying rationale (process variables) associated with juror judgments.

Our findings have both practical and theoretical implications. Our findings indicate that the use of AI in an audit may be consequential for court cases, as it may reduce favorable personal attribution to the defendant and increase associated negligence liabilities in juror judgments.

However, our results also show that this unfavorable effect can be contingent upon whether the work is outsourced. Audit firms that use insourced AI may not suffer litigation risks compared to audit firms that use insourced human staff, whereas the use of outsourced human staff appears to create the lowest risk. Our study also adds to the literatures on the similarity-leniency hypothesis in juror judgments, the role of social identity membership, and the effect of outsourcing in auditing.

The remainder of our manuscript proceeds as follows. In the next section, we introduce relevant theories and develop hypotheses based on the theories. We then introduce the methodology that we use when operationalizing this study. Subsequently we present our analyses and results. We conclude with a discussion, including implications of the study.

## **THEORY AND HYPOTHESES**

### **Artificial Intelligence (AI) and Juror Judgments**

Many industries have been noticing benefits of using artificial intelligence (AI) in professional judgments (Ruta 2018). AI generates more accurate judgments as it gathers additional information and learns from it, but AI does not suffer the fatigue that humans inevitably experience after laboring (Luger 2005). Noticing such benefits, knowledge intensive businesses and services – such as hospitals, finance, and law – have begun using AI-based technology to assist the professional judgments of their staff (Issa, et al. 2016). For example, hospitals have begun testing AI by storing prior patient symptoms and related diagnoses and then allowing the AI system to diagnose a new patient based on his or her symptoms (e.g., Park 2017). Law firms are also now using AI to evaluate business contracts and draft official documents (e.g., Ng 2017).

Accounting firms have also begun developing specialized audit programs based on AI (Zhou 2017). Several major accounting firms have already begun testing the use of AI in audits,

for example, in the area of compiling client information by using automated image recognition (Murphy 2017). Outside technology firms have also begun developing AI-based audit programs, targeting accounting firms that would use their specialized audit programs to partially complete their audit work (Omoteso 2012).

While there are expected benefits of using AI in audits, there are also concerns and risks surrounding the use of AI. First, AI judgments can be fallible given that the system can malfunction and given that it infers judgment patterns from data provided by potentially limited and biased human input (Osoba and Welser IV 2017). AI judgments can also be corrupted by humans, either by hacking or human interruption (Knight 2017). Second, AI endlessly changes algorithms based on new information that is processed; and because those changes are very fast and complicated, it may not be possible or feasible to trace the source of the problem when a misjudgment occurs (Luger 2005). Third, if AI renders a technical judgment and then a human makes use of the judgment, the human may be overly reliant on the AI's judgment (Lee and See 2004). That is, in a case where AI makes an erroneous judgment, it is possible that a human user or supervisor may not sufficiently intercept or correct the misjudgment.

In cases where AI leads to a misjudgment and it is brought before the court, difficulties can arise because most prior court cases deal with human fault (Vladeck 2014); and most laws rely on concepts of human fault, such as negligence, knowledge, intent, and reasonableness (James 1951), likely providing greater discretion to jurors when determining verdicts. However, scant research has explored litigation implications of using AI in an audit (Omoteso 2012).

### **AI vs. Humans: Characteristic Assessment and Personal-Level Attribution**

The similarity-leniency hypothesis in psychology indicates that jurors will provide a more favorable evaluation for and a more lenient judgment against individuals with whom they find

greater similarity to themselves (Davis, et al. 1977). Specifically, when an individual identifies with the other, he or she tends to make relatively more favorable judgments as compared to a less similar other person. Recognition of similarity can be done by way of social categorization (Tajfel, Billig, Bundy, and Flament 1971). For example, individuals may identify themselves with others of the same gender (e.g., Stephan 1974), the same ethnicity (e.g., Bernard 1979; Feild 1979), or the same religious group (e.g., Kerr, et al. 1995). Identification of similarity is not limited to social categorization but can be easily established by, for example, sharing similar characteristics (Dane and Wrightsman 1982; Wrightsman 1987).

The theory indicates that the favorable evaluation of the similar other may happen because of the individual's innate preference towards enhancing his or her own self-image (Tajfel and Turner 1986). They project themselves onto the similar others, and they have an innate tendency to view themselves favorably and to avoid damaging their own self-image (Marques, et al. 1988; Marques and Yzerbyt 1988). Other literature also indicates that the favorable evaluation of the others can be attributed to the judging individuals understanding the others better if they share greater similarity (Gobert and Jordan 1990). Being more understanding of the others, judging individuals are likely to shift their attention more to circumstantial reasons, rather than personal reasons, when assessing the causes of an incident.

In the context of court cases, the similarity-leniency hypothesis suggests that jurors who identify greater similarity with the defendant will tend to evaluate the defendant more favorably (Kerr, et al. 1995). The favorable feelings are also likely to lead jurors to being more understanding of the defendant and perceiving the causes of the incident as less associated with the defendant and more associated with the circumstance. When comparing robots (AI) and humans, the literature documents that individuals feel closer and more comfortable when interacting with

humans rather than with robots (AI) (e.g., Groom, Srinivasan, Bethel, Murphy, Dole, and Nass 2011). We contend that, compared to a scenario in which the wrongdoer is AI, when the wrongdoer is a human, jurors will find greater similarity between the wrongdoer and themselves and will provide a comparatively favorable assessment of the wrongdoer's personal characteristics. This favorable assessment will be extended to the evaluation of characteristics of the audit firm that staffed the wrongdoer. In addition, we assert that jurors will perceive that the causes of the audit failure are less associated with a human defendant and more associated with the surrounding circumstances (that is, they will apply comparatively lower levels of defendant personal-level attribution to the audit failure). The foregoing discussion leads to the following hypotheses:

**H1a** Jurors will more favorably assess characteristics of an audit firm when work is completed by human staff (as compared to AI).

**H1b** Jurors will apply lower personal-level attribution for an audit failure when work is completed by human staff (as compared to AI).

### **Related Effects of Outsourcing vs. Insourcing**

While the similarity-leniency hypothesis suggests that similarity between jurors and the defendant generally results in relatively favorable characteristic evaluations and incident attribution by the jurors, there are limits to this phenomenon. Specifically, the theory suggests that the favorable evaluation of the similar other can be reversed if jurors perceive that the case facts appear to be heavily incriminating of and/or controllable by the defendant – a phenomenon referred to as the “black-sheep effect” (Marques, et al. 1988; Marques and Yzerbyt 1988).

The theory indicates that this phenomenon happens because a defendant who is more similar to the jurors but more clearly associated with a wrongdoing can damage the jurors' own perception of their self-image. Individuals are motivated to view themselves, and those who are



similar to themselves, more positively, and they avoid their self-image being damaged (Tajfel and Turner 1986). Therefore, they will punish more severely if an individual who is similar to themselves projects an evidently negative image (Kerr, et al. 1995). Other research about this phenomenon also suggests that being comparatively more similar to the wrongdoer more readily allows jurors to imagine, if they were put in the same circumstance, what they would have done differently (Golash 1992). Given the innate tendency to maintain positive self-image, individuals tend to think that they would have done much better than the wrongdoer, and the wrongdoer could have done better as they themselves would have done (Golash 1992).

Experimental manipulations in research about the black-sheep effect show that jurors often perceive that the case facts appear to be more incriminating of the defendant when the defendant can be considered to have had more control over the circumstances, when the consequences of their actions were comparatively more dire, or both (e.g., Marques, et al. 1988; Marques and Yzerbyt 1988; Kerr, et al. 1995). In auditing research, Lyubimov, et al. (2012) find that jurors assess higher litigation awards when audit work was completed by auditors with closer organizational proximity (insourcing rather than outsourcing) or closer geographical proximity (onshoring rather than offshoring). Similarly, Brown, Grenier, Pyzoha, and Reffett (2019) find that jurors make a less lenient negligence assessment in the case of an audit failure when the audit involves an internal rather than an external expert because their perceived independence of the audit decreases. Results of Lyubimov, et al. (2012) and Brown, et al. (2019) indicate that jurors are likely to perceive that audit firms have greater control over the work completed by auditors with closer organizational proximity.

We contend that jurors are likely to perceive that a misjudgment made by insourced staff (or insourced AI), rather than outsourced staff (or outsourced AI), should be more readily

controllable by the defendant audit firm. That is, when considering the black-sheep effect, the comparatively favorable evaluation of a firm utilizing human staff will be contingent upon the work being outsourced. Specifically, we expect that the comparatively favorable characteristic assessment of the audit firm when the work has been completed by humans (who share greater similarity with the juror) rather than by AI (sharing less similarity with the juror) is likely to be contingent upon the work being outsourced. In addition, we expect that the comparatively lower levels of personal-level (rather than circumstantial-level) attribution for the wrongdoing will be contingent upon the work being outsourced. This leads to the following hypotheses:

**H2a** The more favorable juror assessment of the characteristics of an audit firm when work is completed by human staff (as compared to AI) will be contingent upon the work being outsourced (as compared to insourced).

**H2b** The lower juror application of personal-level attribution for an audit failure when work is completed by human staff (as compared to AI) will be contingent upon the work being outsourced (as compared to insourced).

### **Effects on Guilty Verdicts**

As noted previously, research finds that individuals evaluate more favorably those with whom they find greater similarity to themselves (Marques, et al. 1988; Marques and Yzerbyt 1988). Research also finds the similarity-leniency effect and black-sheep effect in jurors' final verdicts (e.g., Marques, et al. 1988; Marques and Yzerbyt 1988; Kerr, et al. 1995). Favorable evaluations of the defendant are likely to affect jurors' interpretation of the facts surrounding the wrongdoing. Given that it is difficult for the jurors to notice their own overly lenient interpretation of the facts (Carlson and Russo 2001), their final verdict is also likely to be affected. We contend then that jurors' comparatively favorable characteristic assessment of the audit firm when the work has been completed by humans (who share greater similarity with the jurors) rather than by AI (sharing less

similarity with the jurors), which is predicted to be contingent upon whether the work is outsourced, is likely to persist in the jurors' guilty verdicts. We also contend that the comparatively lower levels of personal-level attribution to the wrongdoer, which is also predicted to be contingent upon whether the work is outsourced, is likely to persist in the jurors' verdicts. Importantly, we contend that jurors' comparatively favorable characteristic assessment of the audit firm and their reduced levels of personal-level attribution of the wrongdoing of the defendant audit firm are not independent of each other. Rather, we contend that the contingently favorable characteristic assessment of the audit firm with the human staff (rather than AI) when it is outsourced (rather than insourced) is likely to lead jurors to assess that the wrongdoing is more associated with the surrounding circumstances, rather than personal fault, thereby leading jurors to less frequent guilty verdicts. We thereby expect a moderated-mediation with two mediators (characteristic assessment and personal-level attribution). This leads to our following moderated-mediation hypotheses:

- H3a** A more favorable juror assessment of the characteristics of an audit firm will be associated with less frequency of a guilty verdict for the audit firm.
- H3b** A lower juror application of personal-level attribution for an audit failure will be associated with less frequency of a guilty verdict for the audit firm.
- H3c** The lesser frequency of a guilty verdict for the audit firm that is associated with work being completed by human staff (as compared to AI) will be driven by the intervening effects of the more favorable assessment of the characteristics of the audit firm and the subsequently lower personal-level attribution for the audit failure, considering the influence of outsourcing (as compared to insourcing) (i.e., full moderated mediation).

Our conceptual model for all of our hypothesized effects is presented graphically in Figure 1. In summary, we predict that the use of human staff (as compared to AI) will have a positive effect on assessments of audit firm characteristics (H1a) and a reductive effect on personal-level attribution of the audit failures (H1b). We further predict that outsourcing (as compared to

**FIGURE 1**  
**A Conceptual Model of the Effect of the Use of Human Staff (vs. AI) and Outsourcing (vs. Insourcing) on Jurors' Guilty Verdicts**

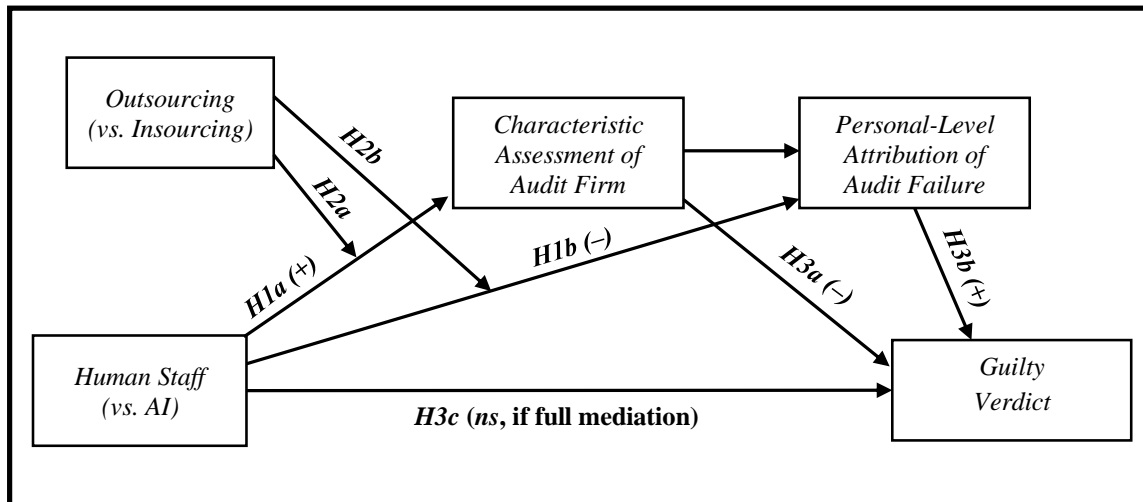

insourcing) will increase (moderate) the positive effect of the use of human staff on assessments of audit firm characteristics (H2a) and the reductive effect on personal-level attribution (H2b). What ultimately matters, though, is the effect on guilty verdicts. We predict that the positive assessment of audit firm characteristics will have a reductive influence on guilty verdicts (H3a), as will the reduced personal-level attribution (H3b). Finally, we predict that the reductive overall effect of the use of human staff on guilty verdicts will be fully attributed to assessments of audit firm characteristics and to personal-level attribution, also considering outsourcing of the work (H3c).

## METHODOLOGY

We use a 2 (human staff completed the audit work vs. AI completed the audit work)  $\times$  2 (outsourcing the work vs. insourcing the work) between-participants experimental design. In the human staff condition, we describe that the initial assessment of the client document in the audit

was completed by audit staff; in the AI condition, we describe that the initial assessment was completed by AI. In the outsourcing condition, we describe that the human staff or AI is sourced from a local office of another audit firm; in the insourcing condition, the human staff or AI is described as being staffed from a local office of the in-charge auditors.

### **Participants**

We recruited 150 participants through Amazon's Mechanical Turk. Only individuals who were at least 18 years of age and U.S. citizens were allowed to participate, representative of a common U.S. jury pool. Our participants were randomly assigned to the four experimental conditions. We excluded 52 participants who failed one or both of our manipulation check questions.<sup>1</sup> This left 98 usable responses. We compensated each participant with \$2 for completing the experimental task.

### **Process Variables Including Mediating and Moderating Variables**

As noted earlier, the similarity-leniency hypothesis indicates that the greater the similarity that a juror feels with a defendant, the more favorably the juror will evaluate the defendant, and the more favorable verdict the juror will provide. However, the theory also suggests that this effect can be reversed if jurors perceive that the wrongdoing can be more readily associated with the defendant rather than the surrounding circumstances.

We thus requested that our participants assess characteristics of the audit firm. Consistent with the social identity literature from which the similarity-leniency hypothesis stems, we requested participants to assess the competence and the knowledge / expertise of the audit firm (as

---

<sup>1</sup> About 34% of our participants failed one or both of our manipulation checks. Lyubimov, et al. (2012) used research instruments with a similar structure and also recruited participants from Amazon's Mechanical Turk, and they reported a comparable failure rate (33%) in their manipulation checks.

relevant characteristics). We use the average of the competence assessment and the expertise assessment as our characteristic assessment score for the defendant audit firm.

We also asked participants to attribute the causes for the audit failure. Specifically, we asked participants to indicate the extent to which the in-charge auditors could have predicted the misjudgment in the audit work. We also asked participants to indicate the extent to which the in-charge auditors could have controlled the quality of the judgment made in the audit work. We use the average of the failure predictability assessment and the quality controllability assessment as our defendant personal-level attribution score for the audit failure. The higher a juror's assessment for these two questions, the higher the juror perceives that the causes for the wrongdoing are attributable at personal rather than circumstantial levels (Kelley and Michela 1980).

### **Control Variables**

We asked whether our participants are CPAs or working as an attorney, as Grenier, Reffett, Simon, and Warne (2017) note that judgments of such individuals could be different from a typical juror. We also asked about prior juror experience.

### **Dependent Variables**

We solicited each participant's verdict (guilty or not guilty) as well as the participant's assessed probability of negligence by the audit firm. In terms of the latter, we asked participants (if they voted guilty) the probability that the audit firm was negligent in performing the audit described in the case, providing a more continuous measure than just the guilty verdict.

### **Task and Experimental Procedure**

We relied upon Grenier, et al.'s (2015) case, with an adaptation of certain facts based on an actual SEC case (SEC 2015) as noted below. We used the same task structure as that of Grenier,

et al. (2015), which is an adaption of the task from Kadous (2000). Specifically, as in Grenier, et al. (2015), our task began by introducing various accounting concepts, such as the purpose of financial statements, the concept of materiality, the purpose of an audit, and the concept of due professional care. The experiment then proceeded to summary facts of the case, including details of a material misstatement from the client fraud as well as details of the audit.

We then presented comprehension check questions, which we created based on suggestions by Peecher and Piercey (2008) and Grenier, et al. (2015). Prior to beginning our task, participants were informed that they would receive comprehension checks after being presented with case facts, and that they would not be able to proceed to the subsequent page unless they successfully answered the comprehension check questions. The comprehension checks included four true / false questions addressing relatively salient facts in the case materials. We made this design choice in order to encourage effortful processing of information by participants but not to limit our participant pool to an excessively knowledgeable or effortful group. Hidden in our programming was also a measure of the number of attempts for each participant for the comprehension check questions.

We then presented participants with the plaintiff's opening statement and the defendant's opening statement, as well as testimonies from their respective witnesses. We balanced the amount and extent of arguments presented by the plaintiff and by the defendant, as recommended by Grenier, et al. (2017).

Our facts are based on an actual SEC case (SEC 2015). In the actual case, the junior staff of the audit firm failed to find irregularity and inconsistencies in the management assumptions supporting the fair value of one of their major oil and gas assets. The in-charge auditor relied upon this misjudgment, failing to identify a material fraud. We changed the names of the companies

involved in the lawsuit, the amount of the material misstatement, and the year in which the incident occurred. Also, we adapted the case to reflect our manipulations, with the cause for the misjudgment being either human audit staff or AI and the related audit work being either outsourced or insourced.

Having read the case facts, participants were then required to provide a verdict (of guilty or not guilty) as well as to assess the probability of negligence, if they deemed that the defendant was guilty. Participants were also required to state their reasoning underlying their negligence assessment.

The subsequent two pages in the experimental instrument included questions for process variables. On the first page, participants were asked to indicate the extent to which the in-charge auditors could have predicted the misjudgment in the audit work, on an 11-point scale (0 = very little extent to 10 = very high extent). We also asked participants to indicate the extent to which the in-charge auditors could have controlled the quality of the judgment made in the audit work, on an 11-point scale (0 = very little extent to 10 = very high extent). On the subsequent page, participants were asked to rate separately the competence and the expertise of the auditor on 11-point scales. Given that Kadous (2000) and Reffett (2010) posit that affect may be one of the leading factors that may influence jurors' assessments, and given that the similarity-leniency hypothesis suggests that jurors will indicate more positive feelings toward humans (similar to themselves) than toward AI, we also measure affect. Specifically, we asked participants to indicate their feelings toward the auditor when reading the case materials (positive, neutral, or negative). The subsequent question asked participants to indicate the strength of their feelings on a 101-point scale.



The next page of the experimental instrument then presented standards of care questions. We presented the standards of care questions after the negligence verdicts and after the questions addressing other process variables given that completing standards of care measures prior may affect jurors' negligence assessments (Maksymov and Nelson 2016).

Our case materials ended with a demographic questionnaire, including questions about whether participants were CPAs and/or attorneys. We also asked whether they had experience in serving as a juror, and if so, how many times. And we asked about their education and profession consistent with the prior psychology literature in the area of juror judgments.

## RESULTS

The 98 usable responses were divided about equally between the conditions, as indicated in Panel A of Table 1. Panel B of Table 1 indicates the participants by condition who indicated they were either a CPA ( $n = 4$ ) and/or an attorney ( $n = 2$ ).<sup>2</sup> Also, 15 of the final participants indicated prior experience as a juror. All of the results are qualitatively similar if we exclude from our analyses the five participants who reported being a CPA and/or an attorney; therefore, for the results reported, all 98 usable responses are included.

Table 2 provides descriptive statistics for the variables of primary interest in our study. Note that, across all conditions, 61% of our participants deemed the auditor guilty in this case and, on average, our participants assessed the auditor to be 55.6% negligent.

Although not related to any specific hypothesis, we initially evaluate the effect of the human/AI manipulation on the guilty verdicts and the negligence assessments. Establishing this main effect is necessary for our later evaluation of the moderated-mediation model, related to H3c.

---

<sup>2</sup> One participant indicated being both a CPA and an attorney.

**TABLE 1**  
**Participant Counts by Experimental Condition**

<i>Panel A. Overall Usable Participant Responses</i>			
	Human Staff	Artificial Intelligence (AI)	Total
Outsourcing	23	26	49
Insourcing	23	26	49
Total	46	52	98
<i>Panel B. CPAs and/or Attorneys in Final Participant Counts</i>			
	Human Staff	Artificial Intelligence (AI)	Total
Outsourcing	2 <sup>a</sup>	0	2
Insourcing	1	2	3
Total	3	2	5
<sup>a</sup> One participant in the human staff / outsourcing condition reported being both a CPA and an attorney.			

Table 3 reports the values for guilty verdict frequencies and for negligence assessments for the human staff condition and the AI condition, and the results of a *t*-test comparison. Consistent with the similarity-leniency hypothesis, our participants less frequently deemed the auditor guilty when the work was completed by human staff (50.0%) than when the work was completed by AI (71.2%). Participants also on average assessed lower negligence by the auditor when the work was completed by human staff (48.7%) than when the work was completed by AI (61.8%).

**TABLE 2**  
**Descriptive Statistics**

	Obs. ( <i>n</i> )	Mean ( $\mu$ )	Median	Std. Dev.	Min.	Max.
<i>Human/AI</i>	98	0.47	0	0.50	0	1
<i>Sourcing</i>	98	0.50	0.50	0.50	0	1
<i>AuditorGuilty</i>	98	0.61	1	0.49	0	1
<i>AuditorNeglig%</i>	98	55.6%	65%	31.9%	0%	100%
<i>CharacAssmntScr</i>	98	4.91	5.00	2.74	0	10
<i>PersLvlAttribScr</i>	98	5.45	5.75	2.34	0	10
<i>FeelingTwrdaudtr</i>	98	-0.13	0	0.60	-1	+1
<i>StdsofCare</i>	98	8.07	8.22	1.63	4.89	11.00

where *Human/AI* = 0 for the AI condition and 1 for the human staff condition  
*Sourcing* = 0 for the insourcing condition and 1 for the outsourcing condition  
*AuditorGuilty* = 0 for not guilty and 1 for guilty  
*AuditorNeglig%* ranges from 0% to 100%  
*CharacAssmntScr* ranges from 0 to 10 and is the average of the assessed competence of the auditor and the assessed expertise of the auditor  
*PersLvlAttribScr* ranges from 0 to 10 and is the average of the assessed ability of the auditor to predict the failure and the assessed ability of the auditor to control the quality of work  
*FeelingTwrdaudtr* = +1 for positive feelings, 0 for neutral feelings, or -1 for negative feelings  
*StdsofCare* ranges from 1 to 11 and is the average of nine separate standards of care scale measures based on Maksymov and Nelson (2016)

### Hypotheses 1a and 2a

H1a predicts a positive main effect of the use of human staff (as compared to AI) on the assessed characteristics of the audit firm. H2a predicts that the positive effect of the use of human staff on the assessed characteristics of the audit firm will be contingent upon the work being outsourced (as compared to being insourced). The average characteristic assessment score was significantly higher for the human staff condition (5.42) than for the AI condition (4.45), providing support for H1a.

**TABLE 3**  
**Effect of Human/AI Manipulation on Guilty Verdicts and Negligence Assessments**

	Human Staff ( <i>n</i> = 46)	Artificial Intelligence (AI) ( <i>n</i> = 52)	<i>p</i> -Value <sup>a</sup>
Guilty Verdict (Frequency)	50.0%	71.2%	0.017
Negligence Assessment	48.7%	61.8%	0.021
<sup>a</sup> Reported <i>p</i> -values are based on one-tailed, heteroscedastic <i>t</i> -tests.			

Collectively, H1a and H2a were evaluated using ANOVA, with characteristic assessment score as the dependent variable and both human/AI condition and sourcing condition, along with the interaction of the two, as independent factors. The effects are illustrated graphically in Figure 2, with the ANOVA results reported in Table 4. The results show the significant (positive) influ-

**FIGURE 2**  
**ANOVA Illustration – Effect of Human/AI and Sourcing Manipulations on Characteristic Assessment of Audit Firm (H1a and H2a)**



**TABLE 4**  
**ANOVA Results – Effect of Human/AI and Sourcing Manipulations on Characteristic Assessments of Auditor (H1a and H2a)**

	Sum of Squares	Deg. of Freedom	Mean Square	F-Stat	p-Value <sup>a</sup>
<i>Human/AI (H1a)</i>	23.06	1	23.06	3.99	0.024
<i>Sourcing</i>	47.18	1	47.18	8.17	0.003
<i>Human/AI × Sourcing (H2a)</i>	112.57	1	112.57	19.49	<0.001
Error	542.86	94	5.78		

<sup>a</sup> Reported *p*-values are based on one-tailed tests.

ence of the use of human staff on the characteristic assessment score ( $p = 0.024$ ), in support of H1a, as well as a significant moderating (interactive) effect of outsourcing ( $p < 0.001$ ), in support of H2a.

### Hypotheses 1b and 2b

H1b predicts a negative main effect of the use of human staff (as compared to AI) on the assessed personal-level attribution of an audit failure. H2b predicts that the negative effect of the use of human staff on the assessed personal-level attribution of an audit failure will be contingent upon the work being outsourced (as compared to being insourced). The average personal-level attribution score was significantly lower for the human staff condition (4.71) than for the AI condition (6.12), providing support for H1b.

Collectively, H1b and H2b were also evaluated using ANOVA, in this case with personal-level attribution score as the dependent variable. The effects are illustrated graphically in Figure 3, with the ANOVA results reported in Table 5. The results show the significant (negative) influence of the use of human staff on the personal-level attribution score ( $p < 0.001$ ), in support

**FIGURE 3**  
**ANOVA Illustration – Effect of Human/AI and Sourcing Manipulations on Personal-Level Attribution for Audit Failure (H1b and H2b)**

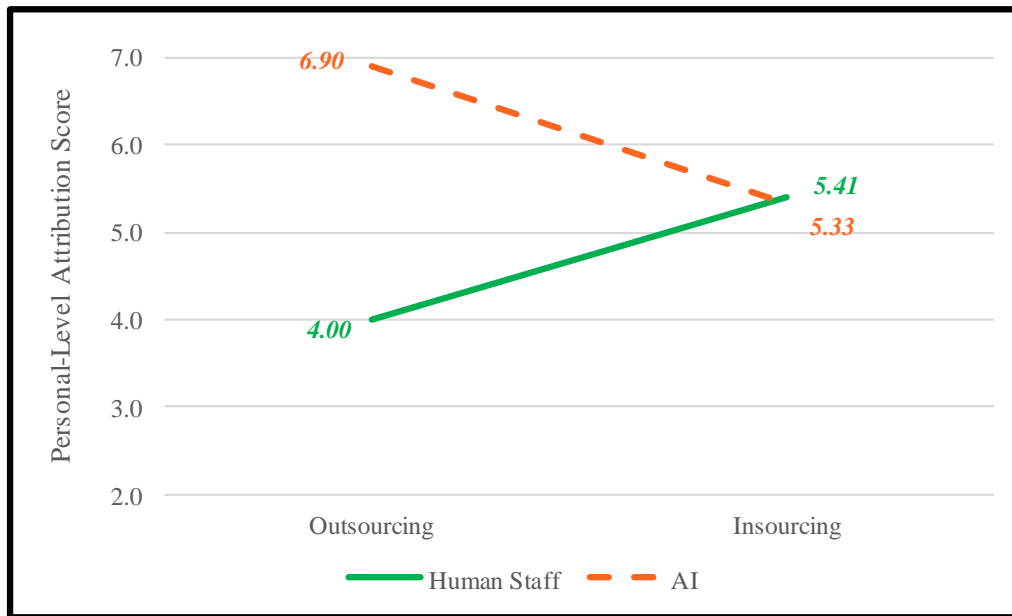

of H1b, as well as a significant moderating (interactive) effect of outsourcing ( $p < 0.001$ ), in support of H2b.

**TABLE 5**  
**ANOVA Results – Effect of Human/AI and Sourcing Manipulations on Personal-Level Attribution for Audit Failure (H1b and H2b)**

	Sum of Squares	Deg. of Freedom	Mean Square	<i>F</i> -Stat	<i>p</i> -Value <sup>a</sup>
<i>Human/AI (H1b)</i>	48.45	1	48.45	10.62	<0.001
<i>Sourcing</i>	0.74	1	0.74	0.16	0.344
<i>Human/AI × Sourcing (H2b)</i>	54.55	1	54.55	11.96	<0.001
Error	428.81	94	4.56		

<sup>a</sup> Reported *p*-values are based on one-tailed tests.

What these results essentially indicate collectively is that jurors provide a higher characteristic assessment of the auditor and lower personal-level attribution, in the case of an audit failure, when human staff rather than AI completes the related audit work; but only if the audit staff is outsourced. If the audit work is completed within the firm (insourced), then jurors do not perceive higher characteristics or lower personal-level attribution for human staff (likely due to the “black-sheep effect”).

### **Hypotheses 3a, 3b, and 3c**

H3a, H3b, and H3c pertain to guilty verdicts. As noted earlier and reported in Table 3, our participants less frequently deemed the auditor guilty when the work was completed by human staff (50.0%) than when the work was completed by AI (71.2%). Before considering the intervening effects of the characteristic assessment and the personal-level attribution, we start by evaluating the overall effect of the human/AI manipulation on guilty verdicts, considering the moderating effect of the sourcing manipulation. We utilize ANOVA to evaluate these effects, with the results provided graphically in Figure 4 and quantitatively in Table 6. The ANOVA results indicate a significant overall effect on the frequency of guilty verdicts from the use of human staff and also an interactive effect on guilty verdicts for the use of human staff and the sourcing, as expected.

H3a predicts that a more favorable characteristic assessment of an audit firm will be associated with a lesser frequency of guilty verdicts. Similarly, H3b predicts that a lower personal-level attribution for an audit failure will be associated with less frequent guilty verdicts. H3c predicts that the more favorable characteristic assessments of an audit firm and the subsequent lower personal-level attribution of the audit failure, considering the influence of outsourcing, will drive the effect of the use of human staff (as compared to AI) on guilty verdicts. That is, H3c pred-

**FIGURE 4**  
**ANOVA Illustration – Effect of Human/AI and Sourcing Manipulations on Guilty Verdicts**

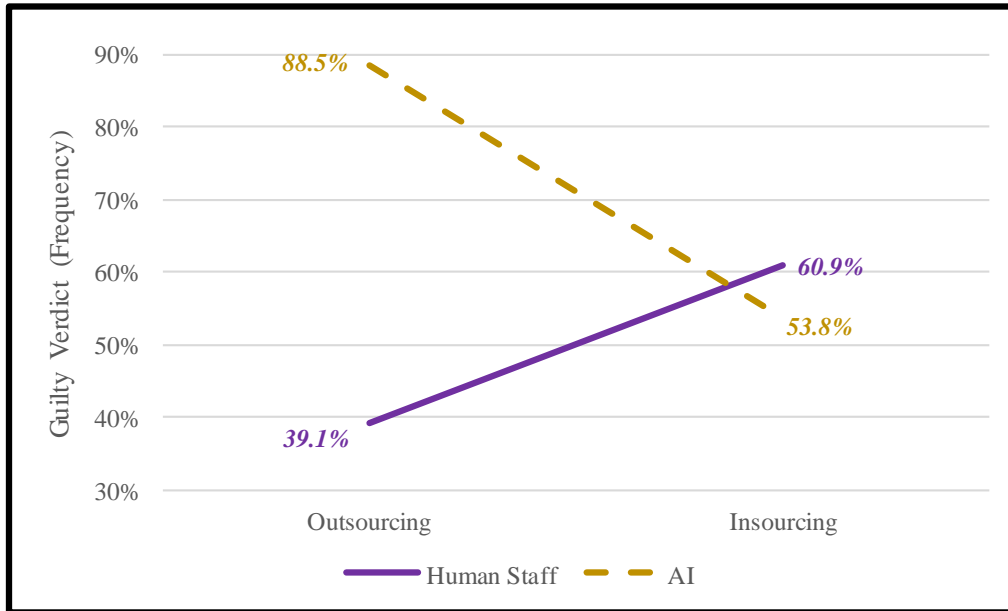

icts that the direct effect of the use of human staff on frequency of guilty verdicts will be eliminated, leaving only an indirect effect by way of the two mediators and considering the moderator.

**TABLE 6**  
**ANOVA Results – Effect of Human/AI and Sourcing Manipulations on Guilty Verdicts<sup>a</sup>**

	Sum of Squares	Deg. of Freedom	Mean Square	<i>F</i> -Stat	<i>p</i> -Value <sup>b</sup>
<i>Human/AI</i>	1.092	1	1.092	5.12	0.013
<i>Sourcing</i>	0.163	1	0.163	0.76	0.192
<i>Human/AI</i> × <i>Sourcing</i>	1.938	1	1.938	9.08	0.002
Error	20.072	94	0.214		

<sup>a</sup> Comparable results are obtained when negligence assessment (*AuditorNeglig%*) is used alternatively as the dependent variable.

<sup>b</sup> Reported *p*-values are based on one-tailed tests.



To evaluate H3a, H3b, and H3c collectively, we utilize the Hayes approach for conditional process (moderated-mediation) analysis under Model 84 (Hayes 2018, 608). Consistent with our conceptual model, Model 84 includes two sequential mediators and one moderator. The results of our moderated-mediation analysis are provided in Table 7.

Consistent with our hypotheses, characteristic assessment score and personal-level attribution score are both significant predictors of the frequency of guilty verdicts; that provides support for H3a and for H3b, respectively. In support of H3c, with these two mediators and the moderator (outsourcing of the work) included in the model, the use of human staff (as compared to AI) is no longer a significant predictor of guilty verdicts ( $p = 0.457$ ).<sup>3</sup> What that means is that the reductive effect of the use of human staff on guilty verdict frequency is only because of the related effects on characteristic assessments of the audit firm and personal-level attribution for the audit failure, and considering sourcing.

**TABLE 7**  
**Moderated-Mediation Results (Hayes Approach) – Effects on Guilty Verdicts (H3a, H3b, and H3c)<sup>a</sup>**

	Parameter Estimate	Standard Error	Z-Stat	p-Value <sup>b</sup>
Intercept	-0.830	2.123	-0.39	0.348
<i>Human/AI</i> ( <b>H3c</b> )	0.083	0.774	0.11	0.457
<i>CharacAssmntScr</i> ( <b>H3a</b> )	-0.751	0.218	-3.45	<0.001
<i>PersLvlAttribScr</i> ( <b>H3b</b> )	1.017	0.304	3.34	<0.001
<sup>a</sup> Comparable results are obtained when negligence assessment ( <i>AuditorNeglig%</i> ) is used alternatively as the dependent variable. <sup>b</sup> Reported <i>p</i> -values are based on one-tailed tests.				

<sup>3</sup> Comparable results are obtained when negligence assessment is used alternatively as the dependent variable.

**FIGURE 5**  
**Factor Loadings for the Effect of the Use of Human Staff (vs. AI) and Outsourcing (vs. Insourcing) on Guilty Verdicts**

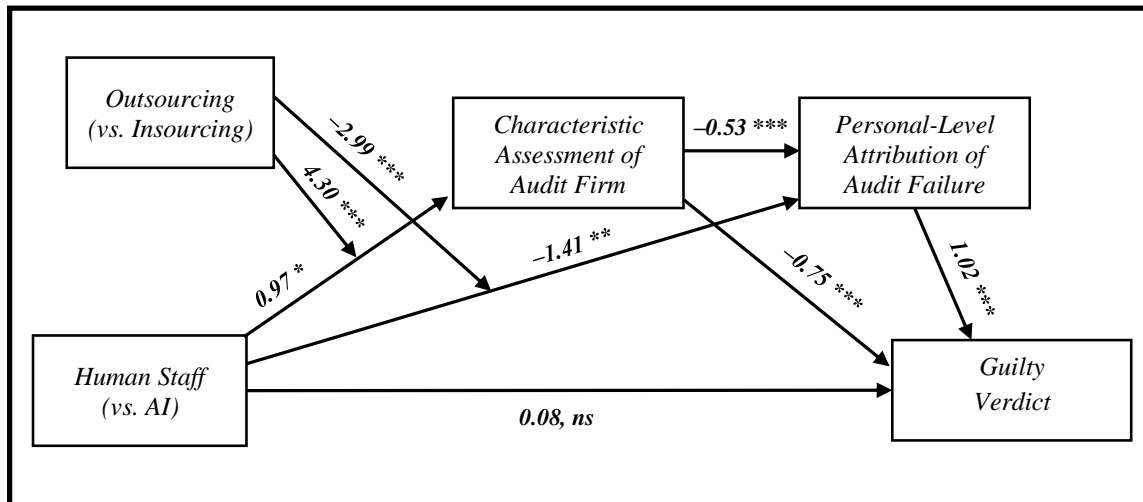

\*, \*\*, and \*\*\* indicates statistical significance at the 0.05, 0.01, and 0.001 level, respectively, based on one-tailed tests

Figure 5 shows our entire conceptual model again, with all factor loadings and related statistical significances indicated.

### Additional Analyses

Recall that the similarity-leniency hypothesis indicates that jurors are likely to be more lenient toward defendants with whom they identify a greater similarity. In our case, we assert that participants will identify more with the human staff. We asked participants whether they had positive (+1), neutral (0), or negative (−1) feelings toward the audit firm. Participants in the human staff condition indicated significantly more positive average feelings toward the audit firm than participants in the AI condition (+0.02 vs. −0.27; one-tailed  $t$ -test,  $p = 0.008$ ), supporting this intervening aspect of the similarity-leniency hypothesis.

A more favorable evaluation of the defendant in an audit failure case is expected to affect the interpretation of the case facts, in a more lenient manner. The quality of audit work is often evaluated using standards of care (SOC) measures. We asked our participants to evaluate nine

SOC measures, each on a 1-to-11 Likert scale (consistent with Maksymov and Nelson 2016). We assert that the effects on negligence assessments discussed earlier should be the result of differences in assessed SOC. Assessed SOC were significantly lower, on average, with the use of human staff as compared to AI (7.66 vs. 8.44;  $p = 0.008$ ). Using assessed SOC as a preceding dependent variable in the analyses for our hypotheses provides generally comparable results as reported previously.

## **DISCUSSION**

AI-based audit software has already been used in audit firms (Omoteso 2012), and it is likely to be used in audits more widely and thoroughly (Issa, et. al 2016). Despite many expected benefits that AI-based software provides, there are also concerns surrounding the use of AI as it is not free from malfunction and/or erroneous judgment (Osoba and Welser IV 2017). And there has been limited investigation of the legal implications of using AI in an audit (Omoteso 2012). While Big-4 firms are making investments to create their own AI-based programs, there are also other technology firms that have developed ready-made AI-based audit software. Thus, in the future, there may be a choice between using insourced software and outsourced software. Litigation implications of using AI in an audit can be further complicated depending on whether it has been insourced or outsourced.

In this study, we investigate how using AI in an audit, compared to having human staff complete the same work, affects juror evaluations of the audit firm and subsequent guilty verdicts and negligence assessments in the case of an audit failure. We also investigate how the work being outsourced or insourced influences the effect of AI on the guilt assessments of jurors. Results from our experiment indicate that, consistent with the similarity-leniency hypothesis, jurors offer more

lenient verdicts and negligence assessments when human staff is used as compared to AI. However, this effect is contingent upon the work being outsourced.

What our results seem to suggest is that when the audit work is completed within the firm (insourced), there is not likely much legal implication of using AI rather than human staff. However, when audit work is completed by an outside firm (outsourced), there may be legal benefits of using human staff in the event of an audit failure. Essentially this would suggest that public accounting firms should continue to consider developing their own AI systems, but might hesitate in utilizing AI systems developed and offered by outside technology firms.

The results of our study also have theoretical importance, as we have provided some clarification for the intervening role of characteristic assessments of the audit firm and personal-level attribution for the audit failure in determining guilty verdicts. Our study also provides theoretical considerations about characteristics to which people may identify themselves more closely and its consequences, in particular between AI and human staff, in an era in which individuals are likely to use AI more widely in their professional judgments.

**REFERENCES**

- Bernard, J. L. (1979). Interaction Between the Race of the Defendant and that of the Jurors in Determining Verdicts. *Law and Psychology Review* 5: 103-111.
- Brown, J. O., Grenier, J. H., Pyzoha, J. S., and Reffett, A. B. (2019). The Effects of Specialist Type and Estimate Aggressiveness on Juror Judgments of Auditor Negligence. *Auditing: A Journal of Practice and Theory* (forthcoming).
- Carlson, K. A. and Russo, J. E. (2001). Biased Interpretation of Evidence by Mock Jurors. *Journal of Experimental Psychology: Applied* 7 (2): 91-103.
- Dane, F. C. and Wrightsman, L. S. (1982). Effects of Defendants' and Victims' Characteristics on Jurors' Verdicts. *The Psychology of the Courtroom*: 83-115.
- Daugherty, B. and Dickins, D. (2009). Offshoring the Independent Audit Function. *The CPA Journal* 79 (1): 60.
- Davis, J. H., Bray, R. M., and Holt, R. W. (1977). The Empirical Study of Decision Processes in Juries: A Critical Review. *Law, Justice, and the Individual in Society: Psychological and Legal Issues*: 326-361.
- Feild, H. S. (1979). Rape Trials and Jurors' Decisions: A Psycholegal Analysis of the Effects of Victim, Defendant, and Case Characteristics. *Law and Human Behavior* 3 (4): 261-284.
- Gobert, J. J. and Jordan, W. E. (1990). *Jury Selection: The Law, Art, and Science of Selecting a Jury* (2<sup>nd</sup> ed.). New York: McGraw-Hill.
- Golash, D. (1992). Race, Fairness, and Jury Selection. *Behavioral Sciences and the Law* 10: 155-177.
- Grenier, J. H., Lowe, D. J., Reffett, A. B., and Warne, R. C. (2015). The Effects of Independent Expert Recommendations on Juror Judgments of Auditor Negligence. *Auditing: A Journal of Practice & Theory* 34 (4): 157-170.
- Grenier, J. H., Reffett, A. B., Simon, C. A., and Warne, R. C. (2017). Researching Juror Judgment and Decision Making in Cases of Alleged Auditor Negligence: A Toolkit for New Scholars. *Behavioral Research in Accounting* 30 (1): 99-110.
- Groom, V., Srinivasan, V., Bethel, C. L., Murphy, R., Dole, L., and Nass, C. (2011). Responses to Robot Social Roles and Social Role Framing. In *2011 International Conference on Collaboration Technologies and Systems (CTS)*: 194-203.
- Hayes, A. F. (2018). *Introduction to Mediation, Moderation, and Conditional Process Analysis: A Regression-Based Approach* (2<sup>nd</sup> edition). New York: The Guilford Press.

Issa, H., Sun, T., and Vasarhelyi, M. A. (2016). Research Ideas for Artificial Intelligence in Auditing: The Formalization of Audit and Workforce Supplementation. *Journal of Emerging Technologies in Accounting* 13 (2): 1-20.

James, Jr., F. (1951). The Qualities of the Reasonable Man in Negligence Cases. *Missouri Law Review* 16 (1): 1-26.

Kadous, K. (2000). The Effects of Audit Quality and Consequence Severity on Juror Evaluations of Auditor Responsibility for Plaintiff Losses. *The Accounting Review* 75 (3): 327-341.

Kelley, H. H. and Michela, J. L. (1980). Attribution Theory and Research. *Annual Review of Psychology* 31: 457-501.

Kerr, N. L., Hymes, R. W., Anderson, A. B., and Weathers, J. E. (1995). Defendant-Juror Similarity and Mock Juror Judgments. *Law and Human Behavior* 19 (6): 545-567.

Knight, W. (2017). The Dark Secret in the Heart of AI: No One Really Knows How the Most Advanced Algorithms Do What They Do. That Could Be a Problem. *MIT Technology Review* (April): 55-63.

Kokina, J. and Davenport, T. H. (2017). The Emergence of Artificial Intelligence: How Automation is Changing Auditing. *Journal of Emerging Technologies in Accounting* 14 (1), 115-122.

Lee, J. D. and See, K. A. (2004). Trust in Automation: Designing for Appropriate Reliance. *Human Factors* 46 (1): 50-80.

Luger, G. F. (2005). *Artificial Intelligence: Structures and Strategies for Complex Problem Solving*. London: Addison-Wesley.

Lyubimov, A., Arnold, V., and Sutton, S. G. (2012). An Examination of the Legal Liability Associated with Outsourcing and Offshoring Audit Procedures. *Auditing: A Journal of Practice & Theory* 32 (2): 97-118.

Maksymov, E. M. and Nelson, M. W. (2016). Malleable Standards of Care Required by Jurors When Assessing Auditor Negligence. *The Accounting Review* 92 (1): 165-181.

Marques, J. M. and Yzerbyt, V. Y. (1988). The Black Sheep Effect: Judgmental Extremity Towards Ingroup Members in Inter- and Intragroup Situations. *European Journal of Social Psychology* 18: 287-292.

Marques, J. M., Yzerbyt, V. Y., and Leyens, J. P. (1988). The Black Sheep Effect: Extremity of Judgments Towards In-Group Members as a Function of Group Identification. *European Journal of Social Psychology* 18: 1-16.

Murphy, H. (2017). Auditing to be Less of a Burden as Accountants Embrace AI. *Financial Times*. <https://www.ft.com/content/0898ce46-8d6a-11e7-a352-e46f43c5825d>. Accessed 27 July 2019.

Ng, I. (2017). The Art of Contract Drafting in the Age of Artificial Intelligence: A Comparative Study Based on US, UK and Austrian Law. *TTLF Working Papers* No. 26, Stanford-Vienna Transatlantic Technology Law Forum: Stanford Law School.

Omoteso, K. (2012). The Application of Artificial Intelligence in Auditing: Looking Back to the Future. *Expert Systems with Applications* 39 (9): 8490-8495.

Osoba, O. A. and Welsch, IV, W. (2017). *An Intelligence in Our Image: The Risks of Bias and Errors in Artificial Intelligence*. Santa Monica, CA: Rand Corporation.

Park, A. (2017). How Robots are Changing the Way You See a Doctor. *Time*. <http://time.com/4967153/artificial-intelligence-machine-learning/>. Accessed 27 July 2019.

Peecher, M. E. and Piercey, M. D. (2008). Judging Audit Quality in Light of Adverse Outcomes: Evidence of Outcome Bias and Reverse Outcome Bias. *Contemporary Accounting Research* 25 (1): 243-274.

Reffett, A. B. (2010). Can Identifying and Investigating Fraud Risks Increase Auditors' Liability? *The Accounting Review* 85 (6): 2145-2167.

Ruta, F. L. (2018). Do the Benefits of Artificial Intelligence Outweigh the Risks? *The Economist*. <https://www.economist.com/open-future/2018/09/10/do-the-benefits-of-artificial-intelligence-outweigh-the-risks>. Accessed 18 February 2019.

Securities and Exchange Commission (SEC). (2015). Order Instituting Public Administrative and Cease-and-Desist Proceedings Pursuant to Section 8A of the Securities Act of 1933, Sections 4C and 21C of the Securities Exchange Act of 1934, and Rules of Practice. In the Matter of Miller Energy Resources, Inc., Paul W. Boyd, CPA, David M. Hall, and Carlton W. Vogt, III, CPA. <https://www.sec.gov/litigation/admin/2015/33-9881.pdf>. Accessed 27 July 2019.

Stephan, C. W. (1974). Sex Prejudice in Jury Stimulation. *Journal of Psychology* 88: 305-312.

Tajfel, H. and Turner, J. (1986). The Social Identity Theory of Intergroup Behavior. *Psychology of Intergroup Relations*: 7-24.

Tajfel, H., Billig, M. G., Bundy, R. P., and Flament, C. (1971). Social Categorization and Intergroup Behaviour. *European Journal of Social Psychology* 1 (2): 149-178.

Vladeck, D. C. (2014). Machines Without Principals: Liability Rules and Artificial Intelligence. *Washington Law Review* 89: 117-150.

Wakabayashi, D. (2018). Self-Driving Uber Car Kills Pedestrian in Arizona, Where Robots Roam. *The New York Times*. <https://www.nytimes.com/2018/03/19/technology/uber-driverless-fatality.html>. Accessed 20 July 2019.

Wrightsman, L. S. (1987). *Psychology and the Legal System*. Belmont, CA: Thomson Brooks/Cole Publishing Co.

Zhou, A. (2017). EY, Deloitte and PwC Embrace Artificial Intelligence for Tax and Accounting. *Forbes*. <https://www.forbes.com/sites/adelynzhou/2017/11/14/ey-deloitte-and-pwc-embrace-artificial-intelligence-for-tax-and-accounting/#70f4da834982>. Accessed 27 July 2019.



## **Maternal and Infant Outcomes in the United States**

**Tyler Davis  
Johnathan Munn  
Caroliniana Padgett**

**Francis Marion University**

### **Abstract**

Maternal and infant outcomes in childbirth continue to steadily improve around the world, including in the United States. Advances in medicine and increased access to healthcare have aided in these improvements at the national level. Relevant literature has cited factors directly correlated with improved outcomes, such as education, income, and access to care. However, there are still large discrepancies in outcomes between mothers and infants residing in urban areas versus rural areas. These discrepancies are particularly large in the United States, where significant differences in infant and maternal outcomes are rising across different geographic areas. Using micro level data from the National Center for Health Statistics, this study aims to investigate whether the factors cited as improving outcomes for both mothers and infants have the same effects for urban and rural mothers and infants. For example, does education improve outcomes in a similar manner for mothers and infants residing in rural areas as it does for mothers and infants living in urban areas? The data provide individual birth statistics for all births from 2008-2018 in the United States. Our model allows us to compare whether factors like education provide the same benefit to all mothers. This provides important policy making information for improving health outcomes across all segments of the United States population. Inconsistencies in how these factors affect each population allows policymakers to decide how to best allocate funding that will increase equality in infant and maternal outcomes across all geographic areas. This is particularly important as the cost structure of healthcare systems continue to shift.

*Preliminary Draft – Please do not cite*

## **Introduction**

We live in a world of advanced technology, advanced medicine and medical treatment, and yet also in a world where mothers and infants suffering from and even dying from pregnancy and childbirth is still an issue. Two ways progress is viewed are through infant and maternal mortality. Infant mortality is defined as “the death of a child within the first year of life.” (Child Health USA 2014, 2014). Maternal mortality is defined as, “deaths that occur due to complications of pregnancy or childbirth, or within six weeks after giving birth.” (Shah, 2018). Women are still having pregnancy complications at alarming rates. According to the World Health Organization (W.H.O.), “About 810 women die from pregnancy- or childbirth- related complications every day.” (World Health Organization [W.H.O.], 2019). While some maternal and infant outcomes have improved over time, certain outcomes have not. “With the exception of 2000–2005, the U.S. infant mortality rate had been consistently declining at least every few years since it was first assessed in 1915.” (Child Health USA 2014, 2014). On the contrary, Shah (2018) reports that per 100,000 deaths, 17 mothers lost their lives in 1990 and that number increased to more than 26 for 2015 in the United States alone. According to the W.H.O., this statistic did decrease to 19 for the United States in 2017. (W.H.O., 2019). In 2016, this rate slightly declined to 16.7 deaths per 100,000 of which half were preventable. (Hayes & McNeil, 2019). Research has been done again and again indicating factors that contribute to infant and maternal outcomes like education, age, cost of healthcare and the list goes on and on. Studies have even shown how improving factors like these also improve outcomes. However, many of these studies are focused within a certain country, certain geographical location, certain area, but as one changes areas, one also changes the status of certain factors. Rural areas tend to have a certain profile while urban areas also have a certain profile. With this being the case, could one

*Preliminary Draft – Please do not cite*

---

uniform treatment improve infant and maternal outcomes across all areas? This study focuses on how the altering of contributing factors to outcomes affects infant and maternal outcomes.

### **Outcome Measurements**

Infant and maternal outcomes are measured by various tools and statistics. To begin, each can be measured by an indication of death which is presented as instances or, more widely used, as a rate. These are called mortality rates. Infant mortality rates (IMR) are measured as infant deaths within one year of birth and given the appropriate conditions per every 1,000 instances. (Elder, Goddeeris, & Haider, 2016). Maternal mortality rates are measured as maternal deaths within the appropriate time frame and given the appropriate conditions per every 100,000 instances.

Outcomes are also measured by health. One very important health factor is weight. Healthy/ unhealthy weight is typically indicated by the body mass index (BMI) and can be seen used when discussing the weight of the mother before and during pregnancy. BMI is based on weight and height of a subject and usually determines obesity. (Mayo Clinic Staff, 2018). Many studies rely on the BMI when measuring the overall health of the mother. However, according to Swainson, Batterham, Tsakirides, Rutherford and Hind (2017) although BMI is the typical way to measure weight, it may not be the most accurate given that it does not account for where body fat on the subject is located. For an expectant mother, this can be vital information. Infant weight is usually measured at birth and is simply known as the birthweight or delivery weight and in the United States, presented using the metric system or by pounds (lbs.) and ounces (oz.).

### **Maternal Factors Before Pregnancy**

*Preliminary Draft – Please do not cite*

Although the child is not yet conceived, there are different things that are a part of the female life that contribute to how their offspring will turn out. Some have been studied before. These include: the education level of the mother, the race of the mother, the marital status of the mother and the overall health of the mother before pregnancy.

Education is one of the most important factors in determining infant and maternal outcomes. Over and over it is proven that the more education a mother receives, the better the outcomes are for the infant. Child Health USA 2014 (2014) reports that the education level of the mother and infant mortality is inversely related. It was found that “infants born to mothers with less than a high school degree is more than twice as likely to die in their first year of life than infants born to mothers with a bachelor’s degree or higher (7.54 versus 3.63 per 1,000). (Child Health USA 2014). A study by Gage, Fang, and O’Neill (2014) also backs this and concludes that higher education levels contribute to improved delivery outcomes like birthweight and declined mortality rates. Child Health USA also concludes that if all children born in the U.S. had the same risks of mortality as those who have mothers with secondary education or higher, the rank in infant mortality rates would jump from 27<sup>th</sup> to 16<sup>th</sup>.

**Figure 2. Infant, Neonatal, and Postneonatal Mortality Rates,\* by Maternal Race/Ethnicity, 2011**

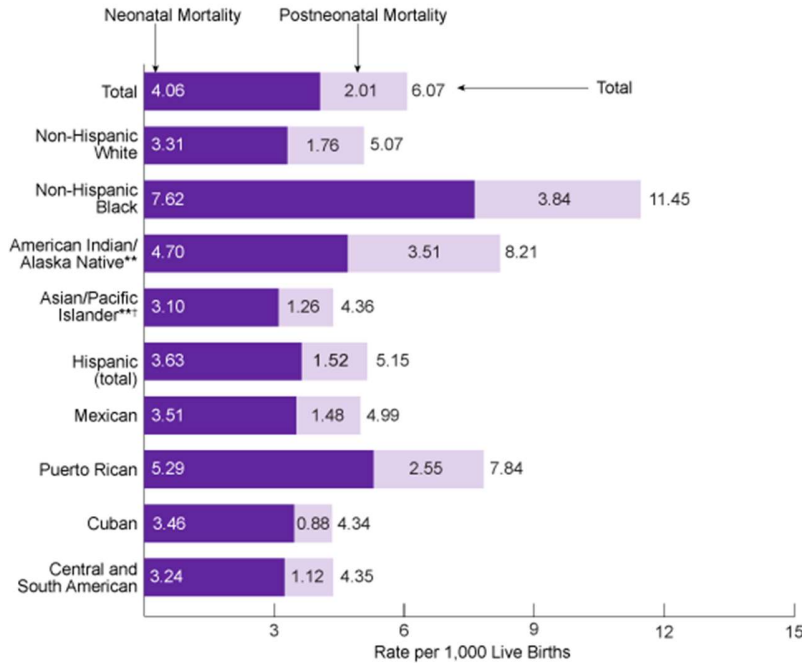

\*Infant deaths are of those less than 1 year old; neonatal deaths are of those less than 28 days old; postneonatal deaths are of those at least 28 days old and less than 1 year old. \*\*May include Hispanics. †Separate data for Asians, Native Hawaiians, and other Pacific Islanders are not available.

Source: U.S. Department of Health and Human Services, Centers for Disease Control and Prevention, National Center for Health Statistics. 2011 Linked Birth/Infant Death File. Analyzed by the U.S. Department of Health and Human Services, Health Resources and Services Administration, Maternal and Child Health Bureau.

**Figure 1: Figure 2 of Child Health USA 2014 Study depicting health disparities among different races.**

Non-Hispanic Blacks. (Gage, Fang, & O’Neill, 2014). Specifically, in 2011 infant mortality rates in the United States was lowest for counties like Cuba and countries within Central America at rates like 4.35 per 1,000 live births. (Child Health USA, 2014). It is also found in this text that for Non-Hispanic Blacks was 2.3 times higher than that of the rate for Non-Hispanic Whites. (Child Health USA, 2014). Child Health USA (2014) takes it even further and states, “If all U.S. infants had the same risk of dying as non-Hispanic Whites, the U.S. ranking among industrialized countries would move from 27<sup>th</sup> to 26<sup>th</sup>.” These rates found among different races are broken down by Child Health USA 2014 (2014) in “Figure 2. Infant, Neonatal, and Postneonatal Mortality Rates,\* by Maternal Race/Ethnicity, 2011,” or for this study Figure 1.

Race also plays a role in both infant and maternal outcomes. Mothers who are Non-Hispanic Blacks tend to have some of the worst outcomes in contrast to Non-Hispanic Whites. It is proven that even with education levels increasing, there is a greater difference in outcomes between Non-Hispanic Whites versus

Migration and cultural appropriation also have a role in health outcomes. Since the 1960's, it has been discovered that Spanish-speaking people of America's population often have a lower infant mortality rate. (Teller and Clyburn, 1974). In this particular study (Ceballos & Palloni, 2011), it was found that Mexican immigrant women who lived in the United States a shorter time (4-12 years) experienced more favorable health outcomes versus Mexican immigrant women who lived in the United States for a longer period of time (13 years or more).

Another factor that is important that takes place before pregnancy is the health history of the mother. The health of the mother includes things such as weight and diet. This also includes other factors such as: the number of previous live births the mother has had and previous morbidity.

### **Maternal Factors During Pregnancy**

The time of pregnancy is of course an important time for both the mother and child. This period is more heavily relies on what the mother does both for herself and the child. This includes things like maintaining a healthy weight and attending prenatal visits. One way to track the progress and health of the mother is through Body Mass Index (BMI) which can indicate if the mother is anywhere from underweight to obese. Some mothers are required to gain and maintain a larger weight than normal during pregnancy. Mothers expecting only one child, if obese, are expected to gain up to 20 lbs. while mothers expecting multiple are expected to gain up to 42 lbs. during pregnancy. (Mayo Clinic Staff, 2019). Obesity, according to Rasmussen and Kesmodel (2011), is diagnosed by a BMI greater than or equal to 30 and overweight is given by a BMI greater than or equal to 25. At the time of the study, over 30% of women were obese and over 50% were overweight or obese all of childbearing age defined as 20-39 years old. These

health risks alone are also concluded to contribute to “many adverse pregnancy outcomes”. (Rasmussen & Kesmodel, 2011). These “adverse outcomes”, are listed by the Mayo Clinic Staff (2019) as things like an uneasy vaginal delivery, the need for a cesarean delivery and even stillbirth to name a few. In fact, Rasmussen and Kesmodel (2011) state that cesarean delivery increases as obesity increases. In their study of Danish women, they found that risk levels went from “14.7% in normal-weight women to 22% in obese women.” Risks like these make it even more important for expecting mothers to regularly visit a healthcare provider. In his study, Henderson (1994) shares that pregnant women who do not seek prenatal care are three times as likely to deliver a low-birthweight child. However, factors such as the cost of healthcare or even insurance coverage, the distance to the healthcare and the amount of obstetric care available affect the actions of the mother. Distance to care also plays a part. In a Ugandan study, it was found that with the access of a 24-hour, free, emergency transportation service, health outcomes improved. This access increased hospital- based deliveries and overall increased the use of health facilities for deliveries. (Mucunguzi, Wamani, Lochoro, & Tylleskar, 2014).

### **Delivery and Infant Factors**

Both infant and maternal outcomes can also depend on the infant. One important factor to consider is the delivery method of the infant. “In 2011, one in three women who gave birth in the United States did so by cesarean (C-section) delivery.” (Obstetrics Care Consensus, 2014). This method of delivery put mothers at a 2.7% risk of having maternal mortality take place or at a rate of 13.3 per 100,000 live births. At the same time, vaginal delivery was only at a 0.9% risk and at a possible rate of 3.3- 7.7 per 100,000 live births. (Obstetrics Care Consensus, 2014). Where the delivery takes place can also be important. According to WHO, “94% of all maternal deaths



Fig. 2. U.S. total cesarean delivery rates by state, 2010. (Data from Martin JA, Hamilton BE, Ventura SJ, Osterman MJ, Mathews TJ. Births: final data for 2011. Natl Vital Stat Rep 2013;62(2):1–90.)

**Figure 2: Cesarean Births in the United States (Obstetric Care Consensus, 2014)**

occur in low and lower middle-income countries.” (2019). As of 2011, the United States was 27<sup>th</sup> in ranking for best to worst infant mortality rates being among other industrialized nations in the ranks. (Child Health USA 2014). Specifically, in the United States, women deliver births in various places whether it be at home or in a hospital. However, even the hospital itself can be an issue. Neel Shah, M.D. reports, “While being overweight, diabetic, or older can make it more likely for a woman to have a C-section, the biggest risk factor is ‘the hospital a mother walks into to deliver her baby, and how busy it is.’” (Haelle, 2018). Across the country, cesarean deliveries vary in amount. These rates can be found in Figure 2. (Obstetric Care Consensus, 2014). In addition, factors like the birthweight of the child, plurality and the sex of the infant play into the outcomes of both the mother and child. Children born as a single child, twin or triplet obtain a decreased infant mortality risk as gestation periods increase. However, children



like quadruplets and quintuplets obtain a nonsignificant risk change as time passes within the pregnancy. (Luke & Brown, 2013).

### **Methods and Data**

To investigate how maternal and infant factors affect outcomes, we propose a logit model that breaks down all births in the US into three categories based on residence and birth location. The first is where the mother resides and gives birth in the same county and state. Next, we compare to mothers who reside and give birth in different counties, but in the same state. Finally, we show the differences then with mothers who reside and give birth in different counties in different states. The question focuses on whether the factors that reduce infant and maternal mortality provide the same effect when the mother chooses or is forced to travel to a different location to give birth.

Data are provided by the CDC National Center for Health Statistics, Division of Vital Statistics. Data is available from 1968-2018 for all live births in the United States. In 2018 for example, 3,801,534 births were recorded.

### **Results and Conclusions Forthcoming**

## References

- Infant Mortality. (2014) Retrieved from <https://mchb.hrsa.gov/chusa14/health-status-behaviors/infants/infant-mortality.html>
- Maternal Health. (2019) Retrieved from [https://www.who.int/health-topics/maternal-health#tab=tab\\_3](https://www.who.int/health-topics/maternal-health#tab=tab_3)
- Shah, Neel. (2018, October 16). A Soaring Maternal Mortality Rate: What Does it Mean For You?. Retrieved from <https://www.health.harvard.edu/blog/a-soaring-maternal-mortality-rate-what-does-it-mean-for-you-2018101614914>
- Maternal Mortality: Levels and Trends 2000-2017. (2019). Retrieved from <http://mmr2017.srhr.org/>
- Staff, Mayo Clinic. (2018). Pregnancy Week by Week. Retrieved from <https://www.mayoclinic.org/healthy-lifestyle/pregnancy-week-by-week/in-depth/pregnancy-and-obesity/art-20044409>
- Rasmussen, S., & Kesmodel, U. (2011, August). Effect of Prepregnancy Maternal Overweight and Obesity on Pregnancy Outcome. *Obstetrics & Gynecology*, *118* (2), 305-312. Retrieved from doi: 10.1097/AOG.0b013e3182245d49
- Swainson, M. G., Batterham, A. M., Tsakirides, C., Rutherford, Z. H., & Hind, K. (2017, May 11). Prediction of Whole-Body Fat Percentage and Visceral Adipose Tissue Mass From Five Anthropometric Variables. *PLoS ONE*, *12* (5). Retrieved from <https://doi.org/10.1371/journal.pone.0177175>
- Gage, T. B., Fang, F., & O'Neill, E. (2014, April 1). Maternal Education, Birth Weight, and Infant Mortality in the United States. *HHS Public Access Author Manuscript Peer-Reviewed and Accepted For Publication Journal*, *50* (2), 615-635. Retrieved from doi: 10.1007/s13524-012-0148-2
- Henderson, James W. (1994). The Cost Effectiveness of Prenatal Care. *Medicare & Medicaid Research Review*, *15* (4), 21-32. Retrieved from <https://www.ncbi.nlm.nih.gov/pmc/articles/PMC4193436/>
- Elder, T. E., Goddeeris, J. H., & Haider, S. J. (2016). Racial and Ethnic Infant Mortality Gaps and the Role of Socio-Economic Status. *Labour Economics*, *43* (2016), 42-54. Retrieved from <https://msu.edu/~haider/Research/2016-labour-published.pdf>
- Hayes, Tara O'Neill & McNeil, Carly. (2019). Maternal Mortality in the United States. Retrieved from <https://www.americanactionforum.org/insight/maternal-mortality-in-the-united-states/>

- Luke, Barbara, & Brown, Morton. (2013, April 11). The Changing Risk of Infant Mortality by Gestation, Plurality and Race: 1989-1991 Versus 1999-2001. *HHS Public Access Author Manuscript Peer- Reviewed and Accepted For Publication Journal*, 118 (6), 2488-2497. Retrieved from doi: 10.1542/peds.2006-1824
- Obstetric Care Consensus. (2014, March 1). Retrieved from [https://www.acog.org/Clinical-Guidance-and-Publications/Obstetric\\_Care\\_Consensus\\_Series/Safe\\_Prevention\\_of\\_the-Primary-Cesarean-Delivery](https://www.acog.org/Clinical-Guidance-and-Publications/Obstetric_Care_Consensus_Series/Safe_Prevention_of_the-Primary-Cesarean-Delivery)
- Haelle, Tara. (2018, May 10). Your Biggest C-Section Risk May Be Your Hospital. Retrieved from <https://www.consumerreports.org/c-section/biggest-c-section-risk-may-be-your-hospital/>
- Mucunguzi, S., Wamani, H., Lochoro, P. & Tylleskar, T. (2014). Effects of Improved Access to Transportation on Emergency Obstetric Care Outcomes In Uganda. *African Journal of Reproductive Health*, 18 (3), 87. Retrieved from <http://www.bioline.org.br/pdf?rh14046>
- Ceballos, Miguel, & Palloni, Alberto. (2011). Maternal and Infant Health of Mexican Immigrants in the United States: The Effects of Acculturation, Duration, and Selective Return Migration. *HHS Public Access Author Manuscript Peer- Reviewed and Accepted for Publication Journal*, 15 (4), 377-396. Retrieved from doi: 10.1080/13557858.2010.481329

## **PROFILING THE DOTCOM BUBBLE AS A PREDICTOR OF TESLA'S FUTURE**

Jasnoor Kaur  
Bryant University  
1150 Douglas Pike  
Smithfield, RI 02917  
[jkaur1@grad.bryant.edu](mailto:jkaur1@grad.bryant.edu)  
(401) 232-6342

Jack Trifts  
Bryant University  
1150 Douglas Pike  
Smithfield, RI 02917  
[jtrifts@bryant.edu](mailto:jtrifts@bryant.edu)  
(401) 447-2201

Cathy Zheng  
Bryant University  
1150 Douglas Pike  
Smithfield, RI 02917  
[czheng@bryant.edu](mailto:czheng@bryant.edu)  
(803) 318-9733

### **ABSTRACT**

The late 1990s, commonly referred to as the “DotCom Bubble”, exhibited optimistic growth for the thriving technology industry. Companies began filing for bankruptcy, bringing this growth to a rapid halt. After surviving the boom and bust of this era, could firms use this as a learning experience in an effort to prevent such failures in the future? Furthermore, could profiling these financial failures be used to predict the future of Tesla, a thriving innovative enterprise? Utilizing relevant data from Compustat and CRSP, a combined data set was created and filtered for the appropriate industries. A logit model of seven control variables was applied to help predict failure for Tesla and like firms. Of the seven variables, four appeared to be major driving factors in predicting bankruptcy. These variables include: profitability, leverage, volatility, and relative size for the firms in the sample period. The findings suggest that bankrupt firms have a lower mean profitability, greater leverage, lower liquidity, lower excess returns, and less cash flow from operations. Tesla has tight cash flow, lower current profitability, but is highly valued by investors, suggesting that investors still believe that the company has a future. The results indicate that Tesla Motors Incorporated has a 1.17% probability for filing for either Chapter 7 or Chapter 11 bankruptcy in the next quarter. Moreover, it has a 0.76% likelihood for default in the upcoming four quarters. These are much lower than the bankruptcy rate of 2.47% for firms of the DotCom Bubble. These findings can be applied to better understand the future for Tesla Inc., and similar firms, that exhibit trends like those in this study. Furthermore, they can be used in creating a plan to help prevent bankruptcy for the firms, increasing success.

## INTRODUCTION

Imagine it is the 1990s and an individual has a great, unique business idea that is expected to improve the lives of millions of Americans across the country. Bringing this idea to life, a new business is created, incorporating the Internet into the business model. In order to attract more consumers and investors, an internet related prefix or a dotcom suffix is added to the name of the company. Venture capitalists begin to pour money into the startups of this time. Firms are entering the public marketplaces, with initial public offerings (IPOs), making shares of the firms available to investors. Valuations for companies begin to surge, exceeding the true worth for many of these firms. Fast forward a few years and this technology bubble has burst, leaving this individual's company, among several hundreds of others, bankrupt.

Today, companies are racing to beat competitors to the public marketplace with offering initial public offerings (IPOs) to investors. Typically, it is extremely profitable to identify and track companies that are planning on, going, or have recently gone public as the major price moves occur during the crucial beginning period. An IPO occurs when a privately-held company makes its shares available on public markets for trading. Such marketplaces include, but are not limited to, the New York Stock Exchange and the Nasdaq. In today's marketplace, companies that have gained investor confidence, despite low profits, are rushing to the public market with shares of company stock.

Companies that dominate the markets today, such as Lyft, Uber Technologies, Snapchat, Pinterest, Airbnb, Robinhood, and more are either going, have gone, or are waiting to go public. In some form or another, these firms can be classified as disruptive technologies. These firm are not disruptive in the sense that Apple was, by creating a market for a new product, the iPhone. Rather, these firms are revolutionizing traditional processes for consumers. These firms remain significantly unprofitable. Despite this, investors remain optimistic about the future of these companies. Tesla Motors Incorporated (Tesla Inc.) exhibits several of the same traits and characteristics of the aforementioned firms of today's market. Tesla Motors Incorporated launched its IPO on June 29<sup>th</sup>, 2010, offering 13.3 million shares for \$17 per share for a total of \$226.1 million. On this day, shares of the firm increased by 40.53%, closing at \$23.89 for the day (Varty, 2019).

Tesla Inc., is continually making headlines on several news broadcasting companies, gaining recognition from investors globally. News about the enterprise is heavily slanted towards "Model 3" production, one of the models of vehicles offered. Alongside this, the firm is consistently on the radar due to the decisions and announcements that are made by its CEO, Elon Musk. It defines itself as a leading American electric car company as it designs, develops, manufactures, and sells electric cars among many other products. The company was founded in 2003, and has expanded to offer a wide array of energy products to consumers (Varty, 2019).

Companies of the late 1990s to early 2000s underwent a period that is known as the DotCom Bubble. Industries were booming, especially the technology sector. Many of these firms traded on the Nasdaq, which is home to many of the largest tech stocks; so as investment and excitement led to increases in stock values, the Nasdaq market index grew fivefold within five years. Although

the value of stocks increased during this time, most of the firms that had inflated valuations were highly unprofitable. These firms were disruptive technologies as they provided consumers with something that was new, the Internet.

Today, firms are experiencing many of the same similarities as those from the last century. Tesla Inc. provides consumers with electric cars, among other products, disrupting the transportation and manufacturing industries. It is providing a new technology to consumers. The company remains unprofitable with a high burn rate, signifying that it is consuming cash at a faster rate than it generates. The company “burns through more than \$7,430 every minute” (Hull, 2018). Lastly, despite the weak financials of the firm, investors remain optimistic about the future and continue to pour capital into the cash consuming giant. Figure 1 illustrates Tesla’s increasingly negative cash flow from operations from its IPO to 2018. Figure 2 further depicts Tesla’s long-term debt surges from its IPO to 2018.

Figure 1: Tesla’s Free Cash Flow from IPO to 2018 (Hull,2018)

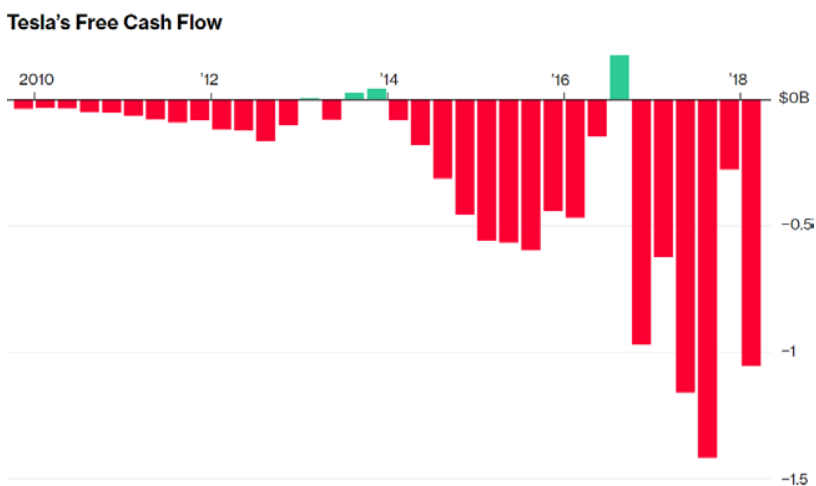
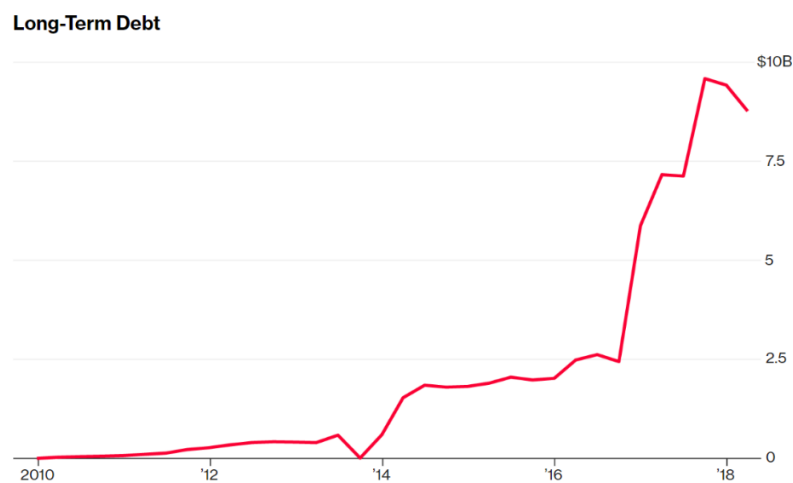

Figure 2: Tesla’s Long-Term Debt from IPO to 2018 (Hull,2018)



Upon comparing the firms of the DotCom Bubble to those dominating the market today, an appropriate connection can be drawn as these firms exhibit similar traits and trends. Firms of today's crop are classified as offering disruptive technologies, being extremely unprofitable, but highly valued by investors. This paper will focus on these traits and trends to ascertain which variables are crucial in determining the bankruptcy of a firm. Furthermore, this paper will delve into these variables and create a forecast to help predict the likelihood of default for Tesla in the upcoming quarter and four quarters.

## LITERATURE REVIEW

### **Bankruptcy –**

In order to best comprehend the time period selected for the course of study and the outcome for several firms, it was important to obtain an accurate understanding of what bankruptcy truly refers to. *“Bankruptcy is a legal process, an option for an individual, family, or corporation who finds themselves unable to pay off their debts”* (Fiorillo, 2018). The ideal objective of bankruptcy is to provide a second chance and fresh start (Fiorillo, 2018). Bankruptcy occurs in the face of creditors who are threatening to seize the assets of a firm if it does not improve its operating performance or financial conditions. The most common form of this in the United States is Chapter 11 bankruptcy, or reorganization. Under this, a firm may submit a plan for reorganization to a bankruptcy judge and the creditors in bankruptcy court. If this plan is approved, then the firm has a second chance at survival. However, if this plan is not approved, or if the firm is too poor to salvage, then the firm will file under Chapter 7, or liquidation. Under this, a firm will liquidate its assets, relieving owners of financial responsibility.

Businesses can fail for a variety of reasons, which often times leaves them with no option except to file for bankruptcy. It is a process used in federal court that is designed to help businesses eliminate or repay current debt under the guidance and protection of the bankruptcy court. There are three types of bankruptcy that a business is able to file for, depending upon its structure. For the purpose of this research, only two of the three types will be focused upon: Chapter 7 and Chapter 11. The owner is responsible for all assets and liabilities of the firm. Corporations and partnerships are legal entities that are separate from their owners, allowing them to file for Chapter 7 or Chapter 11 bankruptcy (Peavler, 2019).

Chapter 7 bankruptcy (business bankruptcy) is most appropriate when the firm in question appears to have no sustainable future. This is often times referred to as liquidation and is used when the firm cannot be restructured due to overwhelming debts. In Chapter 7, a trustee is appointed by the bankruptcy court to obtain possession of the assets of the business and distribute them among creditors. Once this is complete, the trustee is paid, and the sole proprietor receives a “discharge” upon the end of the case. This means that the owner of the business is no longer obligated to repay the debts owed (Peavler, 2019).

Chapter 11 bankruptcy, one of the more common forms of bankruptcy for firms in the United States, allows firms a “second chance”. It provides a plan for a company to reorganize and continue business operations under a court-appointed trustee. For this type of bankruptcy, the firm files a detailed plan of reorganization. This plan outlines how it will deal with creditors.

Upon review, creditors vote on the plan, and if the court rules the plan as fair and equitable, it will be approved. This plan schedules payments to creditors over a defined period, which may exceed twenty years. These bankruptcies are complex, can take up to one year to confirm a plan, and not all succeed (Peavler, 2019).

### **The DotCom Bubble –**

The DotCom Bubble occurred when there was a rapid rise in the U.S. technology stock equity valuations that were driven by investments in Internet-based companies during the bull market of the late 1990s. During this period, the value of the equity markets was dramatically inflated as the technology-dominated Nasdaq index rose from 1,000 to almost 5,000 within five years. During 2001 and 2002, this exponential growth burst and the equities entered into bear markets (Hayes, 2019).

The period consisting of the late 1990s into the early 2000s can be categorized as a bubble, specifically regarding the technology sector. An economic bubble occurs when: *“The price of an asset that may be freely exchanged in a well-established market first soars then plummets over a sustained period of time at rates that are decoupled from the rate of growth of the income that might reasonably be expected to be realized from owning or holding the asset”* (Calculations, 2010). The rapid growth of the computer and internet-technology companies during this period contributed to the bubble and its burst as these companies did not pay significant dividends to shareholders.

The Bubble began as access to the Internet increased significantly, playing a crucial role in people’s lives. Online retailing contributed to this the most, including sites such as Pets.com, 1800contacts.com, and more. Actual returns failed to meet the high expectations for these companies and sent the value of these the stocks plummeting down. Companies were going to the market with inflated IPOs, leading many individuals to start companies. When the crash began, companies began folding and investors became more cautious of investing money into the tech sector. Companies lost their value, as much \$10 and \$30 million a quarter (Geier, 2015).

The 76.81% crash caused most companies to default as they filed for bankruptcy, both Chapter 7 and Chapter 11. Even the share prices of blue-chip technology stocks like Cisco, Intel, and Oracle lost more than 80% of their value (Hayes, 2019).

There were many factors that affected the DotCom Bubble. One of the main sources of the burst was the “combination of speculative or fad-based investing, the abundance of venture capital funding for startups and the failure of dotcoms to turn a profit”. Investors, with their high expectations for the industry, continued to heavily capitalize Internet startups, hoping that the companies would become profitable. Many investors absorbed risky investments in an effort to reap higher returns when the time came for the growing use of the Internet (Hayes, 2019).

During the period, companies were furiously competing with each other to yield high returns and profits. Companies that did not have the fiscal or technological capabilities began to spend excessively on marketing, leaving behind the fiscal responsibility. Some companies spent as much as 90% of their total budget on advertising (Hayes, 2019).



The bubble that was formed with the influx of money was due to unsustainable growth. This growth was fueled by cheap money, easy capital, market overconfidence, and pure speculation. Venture capitalists invested in virtually any company that had “.com” attached to its name. The valuations were based on the earnings and profits that the companies would not see for several years to come if the business models succeeded. IPOs were offered for companies that had yet to generate revenue, profits, and even finished products, which caused their stock prices to increase to three, even four, fold in one day. Investors were blinded by the IPO frenzy, and overlooked the traditional valuation methods. The Nasdaq index peaked on March 10, 2000 at 5048. This dramatic growth was led by companies such as Dell and Cisco, which began to experience large sell orders for their stocks. This caused other investors to experience selling their stocks in panic. Ultimately, the market declined, losing almost 90% of its value within a few weeks. Dotcom companies that had high market capitalizations dropped to become worthless within a few months. By the end of 2001, a large portion of the publicly traded companies filed for bankruptcy, vanishing trillions of dollars in investments (Hayes, 2019).

#### **Tesla’s Historical and Current Performance -**

Tesla, Inc., founded in 2003, was an effort to prove that electric driving did not need to be restricted to a group of engineers. Its mission is to “accelerate the world’s transition to sustainable energy” (Electric Cars). Today, Tesla devotes itself to this mission as it builds both electric vehicles and scalable clean energy generation and storage products. In 2008, the company launched its cutting-edge battery technology and electric powertrain which further enabled it to design the world’s first all-electric sedan, the “Model S”. The company has since expanded its product line with other vehicles including the “Model X”, “Model 3”, and “Tesla Semi”. The CEO, Elon Musk, has a clear vision for the future of the company, but faces many obstacles that are imperative to address.

Besides vehicles, the company also manufactures energy solutions including “Powerwall”, “Powerpack”, and “Solar Roof”, which facilitate renewable energy management. As Tesla moves into the future, it will continue to create products that are accessible and affordable to its consumers, accelerating the move into the next generation of clean transportation and clean energy production, ultimately building the future envisioned by the CEO (Tesla, 2018).

Tesla’s abnormal success, given its low production and quarterly valuation losses, has led investors and professionals to question the future of the company. Tesla has experienced surges in its stock prices and investor expectations, making it an attractive company for many. However, the vehicle safety and company returns has brought to light the negative returns for the enterprise.

Tesla Inc. is the epitome of today’s crop of companies that are racing to the public markets with their IPOs. In today’s fast growing, innovative economy, companies are consistently attempting to gain market presence and recognition in the market by providing new, cutting-edge technologies and services to consumers. Along with this, sustainability is a growing concept that is overtaking several industries, including the automotive. Driven by its mission “to accelerate the world’s transition to sustainable energy” (Electric Cars), Tesla, Inc. strives to provide clean, efficient vehicles to conscientious consumers.

For many, Tesla appears to have emerged as a company that defines the future. The foundation of the firm is innovation, propelling it into the advanced technological era. From its conception to IPO in 2010, Tesla is viewed as a rising force in the industry, revolutionizing the traditional operations. Today, however, Tesla faces several issues that could potentially halt its rapid expansion. With regards to its limited production, surge in valuation, and decrease in credit rating, Tesla shares appear to be declining. Alongside concerns about the company's financial performance, the enterprise faces federal charges from customers after a fatal incident that occurred in one of the company's model vehicles. This reversal of fortune is important to note as several individuals, both within and outside the company, have held high expectations for the company's performance. Its CEO, who has created the Tesla brand, faces difficult decisions in order to sustain the rapid growth the company previously experienced.

Tesla is a common topic that stirs discussion as it is consistently discussed across several news outlets and articles. The company has defied the market by going against traditional operations, dominating the markets and competing with industry leaders. These companies have created their market presence over a certain number of years, and Tesla outperforms them with soaring stock prices. Investors hold high expectations for the future of Tesla, despite its high burn ratio and negative earnings per share.

For those who support Tesla and all it has to offer, Tesla's valuation is justified by its performance and future potential. However, there are also those who doubt the capabilities of the firm and relate it to companies of the DotCom Bubble. The company has a price to book ratio that is almost eleven times higher than some of the failures of the dot-com, but its price to revenue ratio is almost six times healthier as can be seen from Table 1 below, which compares Tesla to several firms of the DotCom era that were disruptive technologies and optimistic investors. (Fahey, 2017).

Table 1: Comparing Tesla to the Doomed DotCom Firms (Fahey, 2017)

#### Tesla as a dot-com

Dot-com company metrics right before the 2000 crash and automotive companies today:

	price to book	price to tangible book	price to sales	market value (\$M)	net income (\$M)
Pets.com	1.7	1.7	23.4	217	-62
Webvan	5.4	5.4	89.7	3,693	-145
Drkoop.com	4.0	4.2	24.5	284	-56
theglobe.com	1.8	3.5	10.6	213	-51
Garden.com	2.2	2.2	24.4	132	-19
eToys.com	5.9	16.9	52.2	1,575	-190
S&P 500 in 2000	5.2		2.4		
<b>Tesla</b>	<b>10.6</b>	<b>11.0</b>	<b>5.9</b>	<b>49,088</b>	<b>-675</b>
General Motors	1.1	1.3	0.3	50,511	9,427
Ford	1.5	1.5	0.3	43,335	4,596
S&P 500 in 2017	3.1		2.0		

Notes: All ratios are LTM; Dotcom company ratios as of March 10, 2000; DotCom market values and income for 1999; Motor companies as of May 3, 2017 and 2016. Source: FactSet



**The DotCom Bubble versus Today –**

The late 1990s into the early 2000s proved to be a booming period for several companies across the nation. Hundreds of companies raced to the public markets with their initial public offerings (IPOs), representing the dream of everyday Americans to gain fortunes through their trading and startup companies. Numerous startups emerged as an embodiment of the entrepreneurial American spirit and became common household names like “Webvan” and “eToys” among many others. During 1999, there were 547 companies that had IPOs in the United States with profits of \$107.9 billion (Cimilluca, 2019).

Today, a similar trend of IPO waves is emerging and could be even bigger. Companies like Lyft Inc., are bringing in \$2.34 billion and are valued at \$26.5 billion after going public on March 28<sup>th</sup>, 2019, further increasing shares by 8.7%. Other companies that are the center of attention for many investors are in the process of or discussing IPOs. Such companies include: Uber Technologies, Pinterest Inc., Snapchat, Airbnb Inc., Slack Technologies Inc., Robinhood, and Postmates Inc. Overall, the companies that are expected to go public in the following year (2019) will surpass the amount that was raised in 1999 (Cimilluca, 2019).

Research conducted by Jay Ritter, an IPO expert at the University of Florida, indicates that companies that are going public today are bigger and older than those of the DotCom era. He explains that the average age for tech companies that went public between 1999 and 2000 was approximately four to five years. In contrast companies in 2018 had an average age of about twelve years. Median sales for companies then were about \$12 million, compared with \$173.6 million in 2018 (Cimilluca, 2019).

Although there are some differences between companies then and now, they share one thing: they are still losing money. Companies like Uber and Lyft are losing large sums of money. Uber lost \$3.3 billion in the previous year, and Lyft lost more than \$900 million. Despite this, these companies have been able to prove that their business model of rides through an app will not disappear over the upcoming years. Uber has a revenue base of over \$11 billion, and Lyft raised more than \$2 billion in the last year. Uber and Lyft dominate the market with 70% and 30% market share respectively. There is lower likelihood for failure for many firms whose performance is similar to that of Uber and Lyft (Cimilluca, 2019).

The shares of companies that debuted during the bubble with sales of over \$100 million outperformed companies with sales below this by approximately 45 percentage points. A similar rough pattern can be seen for the companies after this period. This allows for appropriate comparisons to be drawn between the companies of the DotCom era and those following the period in today’s markets (Cimilluca, 2019).

**Metrics for Consideration –**

It is imperative to identify key metrics that will be used for company comparison. The key identifiers for subsequent success or failure of a firm can be decided through predictors such as bankruptcy, which is measured by the “Altman Z-Score”. Another key factor is the burn rate, which is the rate at which the company is consuming its cash. Furthermore, the company’s cash

flow can be analyzed, which measures the amount of money that firms are generating after accounting for needed investment in working capital and capital expenditure (CapEx). Other non-financial and financial metrics can be studied as well, along with analyzing the internal and external factors that impact the firm (Staff, Investopedia).

### **Sample Firms for Comparison –**

Studying the sources, a few companies have been selected for comparison. While learning about Tesla, several articles referred to a similarity between the current company performance to those of the Dotcom Bubble of the late 1990s. Further investigation of the Bubble revealed that there were several companies that folded during this time due to reasons that appear similar to the track Tesla is on. Tesla is raising concerns for investors due to its high burn ratio and negative EPS and P/E ratio. The company appears to be overvalued given its production issues, but investors are continuing to give money to the business, further powering its market dominance.

Potential companies that can be used as success examples can be: Amazon.com, 1-800contacts.com, and more. Potential failure companies that have been identified are Pets.com and Garden.com (Fahey, 2017).

In order to ensure accurate data collection, it is best to utilize public firms that went bankrupt during the DotCom Bubble. Furthermore, a control sample of firms that did not go bankrupt during this period must also be considered in the analysis of distressed firms.

### **Crafting Methodology –**

A study by Mahajan, Srinivasan, and Wind (2002) was conducted on the Dotcom era and focused on specific retailers of this time to identify the profile of a “winner” company. Because many of these retailers were not profitable in terms of their finances, the study did not use traditional performance metrics like ROA, ROS, and more. Instead, the study focused on the stock price of the firm since IPO, and monitored the performance over the years. The second key performance metric that was used is the value of its stock options that were issued to employees, which is related to the stock price. The study placed greater emphasis on a qualitative analysis of the firms, focusing on the product and firm characteristics. The authors identified a hypothesized winner, in terms of the product offered, to be one that offered digital products, search goods, existing products, product customization. Additionally, the study limited the sample size to online retailers, excluding companies with brick and mortar stores. They comprised a list of 48 publicly traded firms to be used for analysis. The time period under study was confined from the date of the IPO to the end of 2000. Using this criteria, it was predicted that Amazon would be the winner of this bubble, but the study found that 1-800contacts.com was the sole winner. 1-800contacts.com had some similarities in criteria to the hypothesized winner, but differed on many of the characteristics. The research that was conducted by this study has its limitations since the scope of the research is restricted to the firms at the specific point in time. Additionally, the consumer behavior that was identified through the research could change over time (Mahajan et al. 2002). This paper provided a model to be used, helping to solidify the period under examination as the DotCom bubble. The paper focused primarily on a qualitative analysis, but provided framework that could be used to better understand the types of firms that were going public during this time. Further research had

to be conducted in order to better understand the quantitative analysis that must be completed for exploration of the firms.

Expanding upon the research methodology of Mahajan, Srinivasan, and Wind (2002), a study by Wang and Shiu (2014) focuses on analyzing the survival period of firms upon investing the factors that affect the financial distress of firms emerging in the Taiwan market to influence the probability of bankruptcy. The paper is useful in determining the impact of factors through the survival period, which include variables such as liquidity profitability, capital structure, and corporate governance. The analysis was conducted using 228 over-the-counter firms, which includes a mix between corporations and family owned businesses in the Taiwanese markets. Of these firms, 101 businesses went bankrupt, 83 recovered, and 44 firms in financial distress on the path to bankruptcy. The period under study was from January 2000 to July 2011, which included the global financial crisis of 2008. By utilizing a survival analysis and Cox regression model, the survival time for firms under distress is estimated to be 18 months of delisting/bankruptcy, and 23 months for recovery. A Cox regression model is a method that is used to investigate the effect of several variables in a specified event, and is used to study the association between survival period and an outcome such as death (Wang et al. 2014). This paper provides a strong explanation of the types of quantitative measurements that must be considered in order to appropriately evaluate a firm under distress. It was not confined to the time period that is under observation for the purpose of this thesis. However, it does provide a model that can be used to elaborate upon. The focus of this thesis is not to measure the survival period of firms in distress, so the exact models cannot be applied.

The last paper studied, written by John Y. Campbell, Jens Dietrich Hilscher, and Jan Szilagyi (2011) appears to have the strongest correlation between the execution of the study and objective of this thesis. The paper discusses the measurement and pricing of distress risk using accounting and market-based forecasting metrics to predict the likelihood of future financial distress. First, the paper presents a model for predicting financial distress. Secondly, it studies the historical performance of investing in distressed stock portfolios. There are several different approaches in order to predict bankruptcy such as the "Altman Z-score". This last paper utilizes a larger set of explanatory variables in order to have higher forecasting ability. It outlines a clear methodology for predicting financial distress for a given firm, by describing key relevant variables that should be considered. It uses a qualitative approach to effectively develop a model that can be applied to public firms that have experienced Chapter 7 and Chapter 11 bankruptcy. The sample size of over 2 million firm-months, of which 1,750 have experienced failure. The study covers a period from January 1963 until December 2003, which includes the time of interest – the DotCom Bubble. It utilizes a logit model in order to forecast and predict the bankruptcy of firms in to the future, showing a relationship between bankrupt and non-bankrupt firms (Campbell et al. 2011). This paper is most closely related to the objective outlined in this study. It investigates a similar time period, with public firms, and is able to outline detailed methodology for yielding results. This paper will be closely modeled in order to conduct analyses of the variables in this study.

## DATA AND METHODOLOGY

### **Data –**

In order to begin conducting analysis, data must be obtained from reliable sources that list company financial information, along with other relevant data. This type of data is readily available for use from Compustat and the Center for Research in Security Prices (CRSP).

The data examined corresponds to active and inactive firms that were publicly traded. The data from the CRSP source provides daily information for firms between the target years of 1998 and 2001 (1998 quarter 1 to 2001 quarter 4). This data was specifically utilized for stock return data, which results in 134,921 observations with 60 variables. Not each variable presents relevant or complete information. The Compustat data source also yields a large set with 198,243 observations and 1,444 variables. This database provides historical financial data that is further used to help analyze the firms of the time period. Again, this does not provide a complete table of information as several values are missing and duplicated.

The last source of data that is obtained relates to the returns of the S&P 500 index (^GSPC). Quarterly returns are obtained.

Global Company Key (GVKEY) and the Committee on Uniform Securities Identification Procedures (CUSIPs) for each firm provides identification numbers from the Compustat and CRSP data tables.

The final data set that is created upon joining the three sources, results in 32,915 observations. Among these, there are 3,257 unique firms, of which, 78 firms filed for bankruptcy. This is further analyzed indicating that 35 firms were liquidated (Chapter 7) and 43 firms were reorganized (Chapter 11). Refer to Appendix A and B for a complete listing of firms that went bankrupt during 1998 to 2001 along with their identification codes (CUSIPs) respectively.

### **Methodology Overview –**

In order to appropriately obtain meaningful results from the collected data sources, the following steps must be taken:

1. Data Collection
2. Creating a Master File
3. Filtering Data
4. Constructing Variables and Logit Model
5. Summary Statistics of Sample Size
6. Graphing Trends Prior to Bankruptcy
7. Forecasting Variable Impact
8. Prediction of Bankruptcy for Selected Firm

*Steps one to four are discussed below, and steps five to eight are discussed and explained in the “Results” portion of this report.*

## DETAILED METHODOLOGY

### *Step 1: Data Collection*

As mentioned in the Data section of this report, the key sources used in order to collect valuable data are Compustat, CRSP, and quarterly data for ^GSPC.

### *Step 2: Creating a Master File*

In order to do this, the data must be matched among the Compustat and CRSP files using the company identification codes.

### *Step 3: Filtering Data*

With the newly joined data set, it is crucial to filter the data for the relevant information that pertains to this thesis. For the purpose of this capstone project, companies that are capital intensive are utilized in the analysis of the DotCom Bubble. This is done to focus on companies most like Tesla. This data is further filtered for the appropriate industries, specifically manufacturing, electronics and technology, and transportation among others. Lastly, the resulting data set is further consolidated by removing the observations that are duplicates, or that have missing values. This creates a complete, valuable data set for analysis.

### *Step 4: Variables and Logit Model*

#### **Variables:**

The following seven control variables are identified as impacting bankruptcy:

*Profitability:* the efficiency of business activity for a particular firm

$$\frac{\text{Net Income}}{\text{Total Capital}}$$

*Leverage:* firm's assets that are financed using debt

$$\frac{\text{Total Liabilities}}{\text{Total Assets}}$$

*Liquidity:* firm's position of financial strength and liquidity

$$\frac{\text{Cash Holdings}}{\text{Total Capital}}$$

*Excess Returns:* firm's return relative to a market security (S&P 500 for this study)

$$\frac{\text{Actual Return} - \text{S\&P 500 Return}}{\log(1 + R_{it}) - \log(1 + R_{S\&P500,t})}$$

*Volatility:* volatility of firm's stock, riskiness associated with the stock

$$\text{Standard Deviation of Stock over the Prior 3 Months}$$

*Relative Size:* market value of firm capitalization relative to the S&P 500 – this is a control for the size difference

$$\log\left(\frac{\text{Stock's Equity Capitalization}}{\text{S\&P 500 Capitalization}}\right)$$

*Cash Flow from Operations*: amount of cash generated from daily business operations

$$\frac{\text{Cash Flow from Operations}}{\text{Total Capital}}$$

“Total Capital” refers to the sum of the market value of assets and the book value of liabilities.

### **Logit Model:**

A logit model is used in order to run a regression to analyze the key variables of this study in its simple form. For this study, the dependent variable is the status of bankruptcy for a given firm. This variable can have two possible outcomes: 0 = no bankruptcy occurrence or 1 = bankruptcy occurrence. The following logistic model is constructed for seven key identified control variables:

$$\text{BANKRUPTCY}_{i,t+1} = a + \lambda_1 \text{PROFITABILITY}_{i,t} + \lambda_2 \text{LEVERAGE}_{i,t} + \lambda_3 \text{LIQUIDITY}_{i,t} + \lambda_4 \text{EXCESSRETURNS}_{i,t} + \lambda_5 \text{VOLATILITY}_{i,t} + \lambda_6 \text{RELATIVESIZE}_{i,t} + \lambda_7 \text{CASHFLOWOPERATIONS}_{i,t} + \varepsilon_{i,t}$$

In this logit model,  $i$  indexes firms and  $t$  indexes years. The coefficient on each variable,  $\lambda$ , captures the cost of each variable with a more negative value representing higher, or greater, value. A variable that accounts for error is added to the model. These results are later reported in a summary statistics of the sample size.

## **RESULTS**

Upon running the logit model, the following results were obtained and can be interpreted. For better clarity, results are discussed as a continuation of the “Methodology” section of this report.

### *Step 5: Summary Statistics of Sample Size*

The following results are obtained after running an analysis of the final data set that was created with the logit model:



Table 2. Summary Statistics of Sample Firms

Bankruptcy (Chapter 7 or 11)		Profitability	Leverage	Liquidity	Excess Returns	Volatility	Relative Size	Cash Flow Operations
<b>No</b>	Observations	32103	32103	32103	32103	32103	32103	32103
	Mean	-0.006	0.346	-0.002	0.016	0.915	-1.832	0.008
	Standard Deviation	0.040	0.246	0.055	0.347	0.208	2.173	0.074
<b>Yes</b>	Observations	812	812	812	812	812	812	812
	Mean	-0.024	0.447	-0.013	-0.041	0.902	-2.412	-0.011
	Standard Deviation	0.051	0.291	0.069	0.357	0.203	1.517	0.083
	T-Statistics	(9.75)	9.84	(4.38)	(4.53)	(1.71)	(10.62)	(6.62)

A complete summary statistic is found in Appendix C.

Table 3. Description of Sample Size

Total Firms	Bankrupt Firms	Chp 7	Chp 11
3257	78	35	43

As can be seen from Table 3, the sample size consists of 3,257 unique firms. Of this, 78 firms filed for bankruptcy during the selected period of 1998 to 2001. Furthermore, 35 of the bankrupt firms filed for Chapter 7, liquidation, and 43 filed for Chapter 11, reorganization. Analyzing Table 2, the summary statistics of the sample size the total number of observations for the logit model is 32,915. Of this amount, 32,103 observations correspond to non-bankrupt firms, while 812 observations belong to bankrupt firms. Upon analyzing Table 2, the mean profitability for bankrupt firms is significantly lower than the mean profitability of non-bankrupt firms. The mean leverage for bankrupt firms is considerably higher than for non-bankrupt firms. Similarly, to profitability, the mean liquidity for bankrupt firms is lower than that of non-bankrupt firms. Firms that undergo bankruptcy experience extremely low excess returns in comparison to that of the control sample. According to the Table 2, the two classes of firms experience similar volatility during the time period. Bankrupt firms and non-bankrupt firms appear to have relatively similar volatilities, which can be attributed to the fact that these firms are in a period of financial crisis. Generally, firms that experience bankruptcy are smaller than those who do not, according to the summary statistics from this sample. This variable is introduced in order to account for that fact that many of the firms from this period are smaller than the firms that compose the S&P 500 index. Lastly, bankrupt firms experience significantly lower cash flow from the business operations when compared to non-bankrupt firms. These conclusions support the logical hypothesis that as bankrupt firms have weaker performance than non-bankrupt firms. These mean values for the variables are later used to help predict the likelihood of Tesla's default. These corresponding values for Tesla Inc. are obtained using the same data sources previously stated. The following variables serve as inputs for Tesla's corresponding values for the variables:

Table 4: Variable Inputs for Tesla as of 06/30/18

		Profitability	Leverage	Liquidity	Ex.Ret.	Volatility	Rel. Size	Cash Flow Operations
<b>Current Tesla</b> <b>(6/30/2018)</b>	mean	-0.009	0.28	-0.015	0.305	0.031	3.069	-0.007

Table 4 indicates that Tesla has a profitability that is closer to the non-bankrupt firms as of June 30<sup>th</sup>, 2018. It has less leverage than that of non-bankrupt firms as well. Its liquidity exceeds that of bankrupt firms, however, it has significantly higher excess returns in comparison to the non-bankrupt companies. It is less volatile than the firms in the sample size, and is also significantly larger. Lastly, it has a negative cash flow, but it is not as low as that of the bankrupt firms of the DotCom Bubble. In general, Tesla's current financial condition and operational performance seems not to be outstanding, but it is extremely highly valued by investors, which is reflected in the excess returns. This could suggest that Tesla is seen as a company with high growth potential.

#### Step 6: Trend Prior to Bankruptcy for Sample Size

In order to obtain a clear understanding of the performance of bankrupt firms prior to their respective bankruptcy dates, it is imperative to study the period leading up to this occurrence. Evaluating each variable independently, according to time 0, which is the point in time for bankruptcy, a trend can be graphed over the preceding 16 quarters. Upon graphing the seven control variables, four appear to have significant, interesting trends that can be analyzed for further information. The following four graphs represent the trends for: profitability, leverage, volatility, and cash flow from operations. The remaining three graphs for the other variables are referenced in Appendix D.

#### Profitability –

Fig 3. Mean Profitability for Bankrupt Firms 16 Quarters Prior to Bankruptcy



Figure 3 exhibits that the mean profitability for bankrupt firms has a declining trend over the prior 16 periods. At the start of this period, there appears to be a steeper decrease in the profitability of the firms, which begins to stabilize. However, the last 5 quarters prior to bankruptcy show a dramatic decrease before an ultimate stabilization.

**Leverage -**

Fig 4. Mean Leverage for Bankrupt Firms 16 Quarters Prior to Bankruptcy

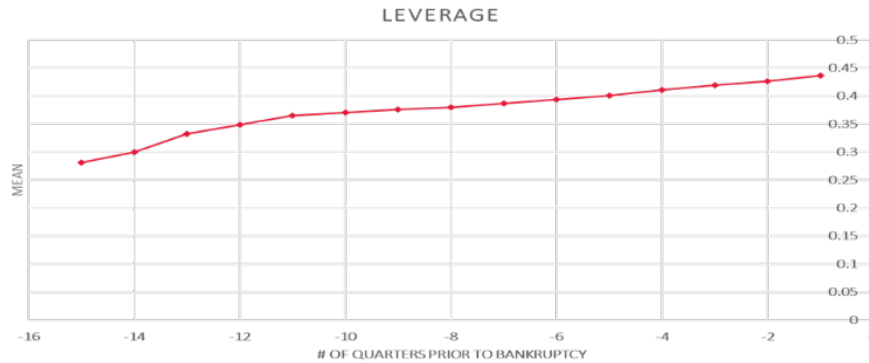

With regards to mean leverage, Figure 4 illustrates that this is relatively constant increase as the firm approaches bankruptcy. This means that the firms' debts are increasing up to the point of declaration, making these debts unable to be repaid.

**Volatility –**

Fig 5. Mean Volatility of Bankrupt Firms 16 Quarters Prior to Bankruptcy

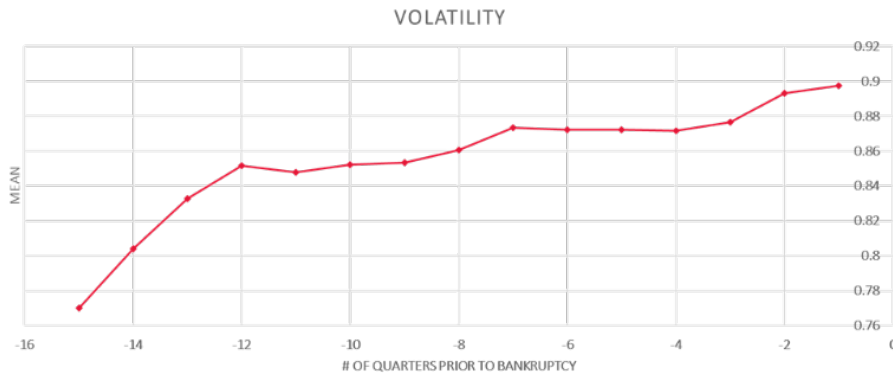

Figure 5 refers to the volatility of bankrupt firms and displays an overall increase in the riskiness of the enterprise. At the beginning of the period, the firms exhibit sharp increases in riskiness, but begin to increase at a more constant rate as they approach bankruptcy.

## Cash Flow from Operations –

Fig 6. Mean Cash Flow from Operations of Bankrupt Firms 16 Quarters Prior to Bankruptcy

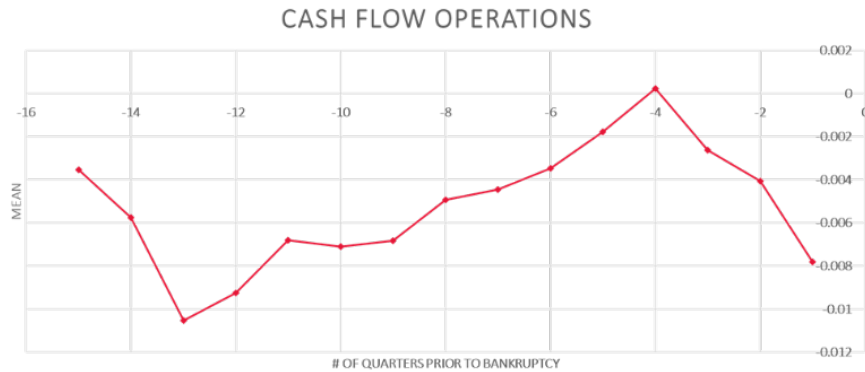

Figure 6 demonstrates a more volatile trend as the cash flow from operations cannot be generalized during this period. However, the last 4 quarters preceding the time of bankruptcy appear to be crucial as it demonstrates that firms experience exaggerated losses in cash flow.

### Step 7: Variable Impact on Predicting Bankruptcy in Future

Once the analysis of the seven control variables is complete, the logit model with the marginal effect is employed in order to directly interpret the coefficients of the model. This reveals that four variables have significant impact on predicting the likelihood of bankruptcy both one and four quarters from now. The following table shows that if the chance of bankruptcy of the control variables increases by one unit, this is how bankruptcy is impacted. A full table with the corresponding z-statistics can be found in Appendix E.

Table 5. Logit Model with Marginal Effect

Logit Model (Marginal Effect)						
VARIABLES	(1)	(2)	(3)	(4)	(5)	(6)
	One Quarter from Now			Four Quarters from Now		
	Reorganization	Liquidation	Both	Reorganization	Liquidation	Both
Profitability	-0.079***	-0.038***	-0.120***	-0.092***	-0.041***	-0.137***
Leverage	0.010***	0.018***	0.030***	0.013***	0.018***	0.032***
Liquidity	-0.021	-0.003	-0.024	-0.007	0.006	-0.002
Excess Returns	-0.001	-0.001	-0.002*	-0.002	-0.001	-0.003
Volatility	0.007**	0.002	0.009	0.012***	0.008*	0.020**
Relative Size	-0.001***	0.000	-0.001***	-0.001***	0.000	-0.001***
Cash Flow from Operations	0.003	-0.014	-0.013	-0.001	-0.011	-0.012
Observations	28,997	28,997	28,997	20,390	20,390	20,390

z-statistics in parentheses  
 \*\*\* p<0.01, \*\* p<0.05, \* p<0.1

Of the seven control variables, four appear to have significant impact on predicting the likelihood of bankruptcy in the future. With greater profitability, firms are less likely to go bankrupt. Furthermore, increased leverage also has a higher likelihood of bankruptcy. Firms with greater volatility increase the likelihood of going bankrupt. Lastly, larger firms will be less likely to

default. These results are consistent with the findings of Campbell, Hilscher, and Szilagyi (2011).

*Step 8: Prediction of Bankruptcy Rate for Tesla*

The last step of the process is to predict and analyze the default rate for Tesla Motors Incorporated. In order to complete this, the inputs from Table 4 are used to complete the logit model. Once this model is run, using the values for each of the control, the bankruptcy rate is obtained for Chapter 7, Chapter 11, and either Chapter 7 or Chapter 11.

Table 6: Bankruptcy Rate for Tesla Inc.

	Tesla		Sample Firms
	1 Quarter from Now	4 Quarters from Now	
<b>Reorganization</b>	0.57%	0.44%	1.48%
<b>Liquidation</b>	0.64%	0.32%	0.98%
<b>Both</b>	1.17%	0.76%	2.47%

After running the model, the default rate for Tesla is generated, distinguished by the type of bankruptcy. Table 6 reports that Tesla is almost half as likely to file for Chapter 11 bankruptcy (reorganization), as compared with the sample firms in this study. Similarly, it is also less likely to file for liquidation (Chapter 7). Lastly, it appears that the enterprise is less probable to file for either Chapter 7 or Chapter 11 bankruptcy, as compared with the sample firms in this study from 1998 to 2001. This table exhibits the bankruptcy rate for the firm specifically one quarter from now four quarters from now. Overall, after examining the factors that contribute to bankruptcy for a firm, and running a logit model for prediction of default rate, Tesla has lower than average chances of filing for each type of bankruptcy examined in this study.

## CONTRIBUTIONS & IMPLICATIONS

Upon complete analysis of the period that is commonly referred to as the DotCom Bubble, it appears that profitability, leverage, excess returns, and volatility have a crucial role in the probability of a company to file for bankruptcy. Of these four variables, Table 5 leads to the conclusion that profitability and leverage are clear drivers of bankruptcy for a firm along with volatility and relative size. The logit model that is used to run the analysis produces intuitive results: distressed stocks perform worse than healthy stocks. Projected one and four quarters into the future, this trend continues, which can be seen from Table 5. These results are consistent with previous studies. Applying this model to Tesla suggests that the firm has less of a likelihood for following the failure path of its predecessors from the DotCom era. This does not mean that Tesla will not go bankrupt in the future, however, it does not appear to be as likely as for the firms during this period of financial crisis. This can further be applied to companies like Tesla today, who are

filing for IPOs, or headed on the same path.

The technology industry today is thriving as numerous companies are gaining popularity among consumers as they attempt to facilitate the daily lives of individuals. Investors continue to remain optimistic about such firms, similar to those of the DotCom Bubble. However, just like the companies of the late 1990s, these prominent firms are losing cash each day. The main question remains: is this trend sustainable for the giants of today's market?

Using the analysis conducted in this study, it is apparent that the firms similar to that of Tesla face less of a chance of filing for Chapter 7 and Chapter 11 bankruptcy. To be exact, they are almost half as likely to default. This can further be utilized in order to create a contingency plan in case of abnormal circumstances, which lead to bankruptcy. Firms of today's crop can use this as lessons in order to prevent following the gloomy fate of the giants of the 1990s.

These results further suggest that investors should steer clear of distressed stocks. It is imperative to gather information of a firm's health, perhaps using the metrics in this study. Investing in stocks that are perceived as not distressed can help to diversify portfolios, specifically the riskiness involved, while increasing returns.

### **LIMITATIONS & FUTURE STEPS**

This study is confined to examining the period that is known as the DotCom Bubble (1998-2001). Perhaps expanding the time period of study would yield stronger results as it would be able to help create behavioral trends for firms before and after, observing a longer period of time. For the purpose of this study, specific, capital intensive industries were selected to focus on. Expanding the industry selection to others could be interesting to see if firms within different industries behave differently.

Furthermore, some firms are consistently in the news for different reasons. Tesla has gained widespread publicity for its inability to match demand, fatal car accidents, and CEO, Elon Musk's, debated management style. These factors affect the company in numerous ways, and could be interesting to study in the future.

A logistic model is applied to study the sample size and Tesla Inc. This model is appropriate in order calculate the probability of an event happening based on factors that are a part of the model, with a dependent variable with dichotomous values. It uses a logit transform to provide the outcome of these probabilities. A Cox regression is used to explore the relationship between the "survival" of a sample size and the explanatory variables that are selected. Perhaps, the study could be expanded to estimate the survival period for the firms in distress for this time using the Cox regression, further implementing this to analyze the survival period of firms in today's market.

The study focuses on accounting and market-based measure to forecast failure, but it does not take into account the qualitative analysis that is presented by other authors in the field. Perhaps

incorporating qualitative measures, such as firm characteristics, structure of the firm, or effectiveness of management, in order to obtain a better understanding of the firm's performance. Analyzing metrics that could be incorporated in further studies could strengthen the analysis and provide a holistic understanding of bankruptcy for these firms. Such variables include: customer satisfaction, customer retention, product/firm characteristics, management styles of executives, amongst many others. Combining these metrics could provide for a well-rounded analysis for the causation of bankruptcy and a stronger plan for prevention.

## APPENDIX

### Appendix A - Complete Listing of Chapter 7 Firms (Liquidation)

CVKEY	Company Legal Name	Company Name
1703	Applied Magnetics Corp	APPLIED MAGNETICS CORP
2033	Fairchild Corp. (The)	FAIRCHILD CORP -CL A
3684	Axiom Transaction Solutions	AXIOHM TRANSACTION SOLUTIONS
4352	Energy Conversion Devices Inc	ENERGY CONVERSION DEV
4768	Fleetwood Enterprises Inc.	FLEETWOOD ENTERPRISES INC
4918	Frozen Food Express Industries Inc	FROZEN FOOD EXPRESS INDS
6012	Incomnet Inc	INCOMNET INC
6140	Interstate Bakeries Corp	INTERSTATE BAKERIES CORP
8003	Northwestern Steel & Wire	NORTHWESTERN STL&WIRE
9532	Sea Containers Ltd.	SEA CONTAINERS LTD -CL A
9650	Sheldahl Inc	SHELDAHL INC
10764	TulTEX Corp	TULTEX CORP
12828	Nutrition 21 Inc	NUTRITION 21 INC
13470	Waterford Wedgwood PLC	WATERFORD WEDGWOOD PLC
13914	Calcomp Technology Inc	CALCOMP TECHNOLOGY INC
23133	Nutramax Products Inc	NUTRAMAX PRODUCTS INC
24438	Imagyn Medical Technologies	IMAGYN MEDICAL TECHNOLOGIES
25777	Caraustar Industries Inc	CARAUSTAR INDUSTRIES INC
28127	Starter Corp	STARTER CORP
28502	Electroglas Inc	ELECTROGLAS INC
28947	National R.V. Holdings Inc.	NATIONAL R V HOLDINGS INC
28983	Micro Component Tech	MICRO COMPONENT TECH
28998	LodgeNet Interactive Corp	LODGENET INTERACTIVE CORP
30307	Metrotrans Corp	METROTRANS CORP
31097	Premier Laser Systems	PREMIER LASER SYSTEMS -CL A
61095	Palm Harbor Homes Inc	PALM HARBOR HOMES INC
61436	Wireless One Inc	WIRELESS ONE INC
62323	TMCI Electronics Inc	TMCI ELECTRONICS INC
62750	Digital Transmission Systems	DIGITAL TRANSMISSION SYSTEMS
63483	Dura Automotive Systems Inc	DURA AUTOMOTIVE SYS -CL B
64308	Photoelectron Corp	PHOTOELECTRON CORP
65143	Excelsior-Henderson Motorcycle	EXCELSIOR-HENDERSON MTRCYCLE
65148	Trailer Bridge Inc	TRAILER BRIDGE INC
66409	USN Communications Inc	USN COMMUNICATIONS INC
220489	Altos Hornos De Mexico	ALTOS HORNOS DE MEXICO
<b>Total</b>		<b>35</b>

## Appendix B - Complete Listing of Chapter 11 Firms (Reorganization)

GVKEY	Company Legal Name	Company Name
1762	Armstrong Holdings Inc	ARMSTRONG HOLDINGS INC
1943	BMC Industries Inc	BMC INDUSTRIES INC
2189	Bethlehem Steel Corp	BETHLEHEM STEEL CORP
2215	Sames Corp	SAMES CORP
2606	Cagle's Inc.	CAGLE'S INC -CL A
2785	Healthy Planet Products Inc.	HEALTHY PLANET PRODUCTS INC
2916	Champion Enterprises Inc.	CHAMPION ENTERPRISES INC
2982	Chesapeake Corp.	CHESAPEAKE CORP
4520	Fab Industries Inc.	FAB INDUSTRIES INC
5166	Salient 3 Communications Inc	SALIENT 3 COMMUN INC -CL A
6130	Interphase Corp	INTERPHASE CORP
9443	Scan Optics Inc.	SCAN OPTICS INC
11907	DPAC Technologies Corp	DPAC TECHNOLOGIES CORP
20194	Hauser Inc	HAUSER INC
21504	Cone Mills Corp	CONE MILLS CORP
21763	Three-Five Systems Inc.	THREE-FIVE SYSTEMS INC
23135	Verdant Brands Inc	VERDANT BRANDS INC
23605	Cygnus Inc	CYGNUS INC
23820	Winstar Communications	WINSTAR COMMUNICATIONS
24100	Metatec Inc.	METATEC INC
24727	CanWest Global Communications Corp.	CANWEST GLOBAL COM -NVTG
24850	Menley & James Inc	MENLEY & JAMES INC
26015	Trident Microsystems Inc	TRIDENT MICROSYSTEMS INC
26898	AutoImmune Inc	AUTOIMMUNE INC
28109	Henley Healthcare Inc	HENLEY HEALTHCARE INC
28253	Auspex Systems Inc	AUSPEX SYSTEMS INC
30088	Fusion Networks Holdings Inc	FUSION NETWORKS HOLDINGS INC
30100	Nucentrix Broadband Networks	NUCENTRIX BROADBAND NETWORKS
30257	Northfield Laboratories Inc	NORTHFIELD LABORATORIES INC
31195	Crown Pacific Partners LP	CROWN PACIFIC PARTNERS -LP
60993	Martin Industries Inc/DE	MARTIN INDUSTRIES INC/DE
61571	Simon Transportation Services Inc	SIMON TRNSPT SVCS INC -CL A
61921	Cronos Group (The)	CRONOS GROUP
62170	Neose Technologies Inc	NEOSE TECHNOLOGIES INC
65708	Tropical Sportswear Int'l Corp	TROPICAL SPORTSWEAR INTL CP
66450	AstroPower Inc.	ASTROPOWER INC
124794	Radio Unica Communications Corp	RADIO UNICA COMMUNICATIONS
127481	Maxygen Inc	MXYGEN INC
128764	Turnstone Systems Inc	TURNSTONE SYSTEMS INC
134453	360Networks Inc	360NETWORKS INC
138490	3-Dimensional Pharmaceutical	3-DIMENSIONAL PHARMACEUTICAL
138924	Integrated Telecom Express	INTEGRATED TELECOM EXPRESS
140441	Advanced Switching Communications Inc	ADVANCED SWITCHING COMM INC
<b>Total</b>		<b>43</b>

## Appendix C – Complete Summary Statistics for Control Variables and Sample Size

Bankruptcy (Chapter 7 or 11)		Profitability	Leverage	Liquidity	Excess Returns	Volatility	Relative Size	Cash Flow Operations
<b>No</b>	Observations	32103	32103	32103	32103	32103	32103	32103
	Mean	-0.006	0.346	-0.002	0.016	0.915	-1.832	0.008
	Standard Deviation	0.040	0.246	0.055	0.347	0.208	2.173	0.074
<b>Yes</b>	Observations	812	812	812	812	812	812	812
	Mean	-0.024	0.447	-0.013	-0.041	0.902	-2.412	-0.011
	Standard Deviation	0.051	0.291	0.069	0.357	0.203	1.517	0.083
	T-Statistics	(9.75)	9.84	(4.38)	(4.53)	(1.71)	(10.62)	(6.62)
	Pooled Standard Error	0.002	0.010	0.002	0.013	0.007	0.055	0.003
	Difference in Mean (Yes-No)	-0.018	0.101	-0.011	-0.057	-0.012	-0.580	-0.019



Appendix D – Trend Graphs of Variables 16 Quarters Prior to Bankruptcy

**Liquidity**



**Excess Returns**



**Relative Size**

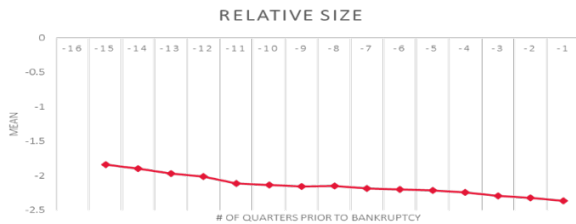

Appendix E – Summary Statistics for Forecast of Sample Size

Logit Model (Marginal Effect)						
VARIABLES	a quarter from now			four quarters from now		
	reorganization	liquidation	both	reorganization	liquidation	both
<b>Profitability</b>	-0.079*** (-5.39)	-0.038*** (-5.55)	-0.120*** (-7.92)	-0.092*** (-3.94)	-0.041*** (-33.63)	-0.137*** (-5.43)
<b>Leverage</b>	0.010*** (4.46)	0.018*** (5.75)	0.030*** (5.91)	0.013*** (4.06)	0.018*** (22.37)	0.032*** (12.64)
<b>Liquidity</b>	-0.021 (-0.74)	-0.003 (-0.33)	-0.024 (-0.66)	-0.007 (-0.18)	0.006 (0.56)	-0.002 (-0.04)
<b>Excess Returns</b>	-0.001 (-0.34)	-0.001 (-0.90)	-0.002* (-1.65)	-0.002 (-0.48)	-0.001 (-1.61)	-0.003 (-1.16)
<b>Volatility</b>	0.007*** (2.42)	0.002 (0.60)	0.009 (1.45)	0.012*** (2.60)	0.008* (1.91)	0.020** (2.25)
<b>Relative Size</b>	-0.001*** (-8.35)	0.000 (1.11)	-0.001*** (-4.80)	-0.001*** (-59.62)	0.000 (0.10)	-0.001*** (-2.96)
<b>Cash Flow from Operations</b>	0.003 (0.18)	-0.014 (-1.46)	-0.013 (-0.46)	-0.001 (-0.04)	-0.011 (-1.12)	-0.012 (-0.34)
<b>Observations</b>	28,997	28,997	28,997	20,390	20,390	20,390

z-statistics in parentheses  
 \*\*\* p<0.01, \*\* p<0.05, \* p<0.1

## REFERENCES

- [1] 15 Most Memorable Companies That Vanished.” NBCNews.com, NBCUniversal News Group, 26 Jan. 2011, [www.nbcnews.com/id/41027460/ns/business-us\\_business/t/most-memorable-companies-vanished/#.WxCduUgvw2w](http://www.nbcnews.com/id/41027460/ns/business-us_business/t/most-memorable-companies-vanished/#.WxCduUgvw2w).
- [2] Blank, Steve. (2018, May 01). To Understand the Future of Tesla, Look to the History of GM. Retrieved June 12, 2018, from <https://hbr.org/2018/04/to-understand-the-future-of-tesla-look-to-the-history-of-gm>.
- [3] Boudette, Neal E. “Tesla Looked Like the Future. Now Some Ask If It Has One.” The New York Times, The New York Times, 29 Mar. 2018, [www.nytimes.com/2018/03/29/business/tesla-elon-musk.html](http://www.nytimes.com/2018/03/29/business/tesla-elon-musk.html).
- [4] Calculations, Political Ironman. (2010, December 15). Here's Why The Dot Com Bubble Began And Why It Popped. Retrieved June 08, 2018, <https://www.businessinsider.com/heres-why-the-dot-com-bubble-began-and-why-it-popped-2010-12>.
- [5] Campbell, John., Jens Dietrich Hilscher, and Jan Szilagyi. 2011. Predicting financial distress and the performance of distressed stock. *Journal of Investment Management* 9(2); 14-34.
- [6] Cimilluca, Dana. (2019, March 30). The 2019 IPO Frenzy Is Different From 1999. Really. Retrieved from <https://www.wsj.com/articles/the-2019-ipo-frenzy-is-different-from-1999-really-11553918401>.
- [7] Delventhal, Shoshanna. “Is Tesla 'Too Big to Fail'? Morgan Stanley Says Yes.” Investopedia, Investopedia, 19 Apr. 2018, [www.investopedia.com/news/tesla-too-big-fail-morgan-stanley-says-yes](http://www.investopedia.com/news/tesla-too-big-fail-morgan-stanley-says-yes).
- [8] Dotcom Boom and Bust: The Secrets of E-Commerce Failure and Success." *Strategic Direction*, vol. 21, no. 2, Feb. 2005, pp. 30-31. EBSCOhost.
- [9] Electric Cars, Solar Panels & Clean Energy Storage | Tesla. (n.d.). Retrieved June 06, 2018, from <https://www.tesla.com/>.
- [10] Fahey, Mark. (2017, May 10). Tesla's valuation raises grim reminders of the dot-com bubble. Retrieved July 13, 2018, from <https://www.cnn.com/2017/05/05/teslas-valuation-raises-grim-reminders-of-the-dotcom-bubble.html>.
- [11] Fiorillo, Steve. (2018, September 11). What Is Bankruptcy? Different Types and Why People File. Retrieved from <https://www.thestreet.com/markets/bankruptcy/what-is-bankruptcy-14708068>.
- [12] Foxman, Simone and Joshua Fineman. (2017, Apr 25). Einhorn’s Greenlight Warns of Bubble as Tax Reform Hopes Dim. *Bloomberg Wire Service*.
- [13] Geier, Ben. (2015, March 12). Tech Stocks and the 2000 Dotcom Bust: 15 Years of Wall Street Lessons. Retrieved June 23, 2018, from <http://time.com/3741681/2000-dotcom-stock-bust/>.
- [14] George, Bill. (2018, August 29). Tesla's real problem isn't its shareholders. Retrieved August 29, 2018, from <https://www.cnn.com/2018/08/29/teslas-real-problem-isnt-its-shareholders.html>.
- [15] Goldman, David. “10 Big Dot.com Flops.” *CNNMoney*, Cable News Network, 10 Mar. 2010, [money.cnn.com/galleries/2010/technology/1003/gallery.dot\\_com\\_busts/](http://money.cnn.com/galleries/2010/technology/1003/gallery.dot_com_busts/).
- [16] Hayes, Adam. (2019, April 02). Dotcom Bubble Definition. Retrieved from <https://www.investopedia.com/terms/d/dotcom-bubble.asp>.
- [17] Heath, Thomas. (2017, Apr 17). Tesla’s Climb to America’s Most Valuable Car Company. *Telegraph-Journal*.

- [18] Herwarth Kohn, Maximilian-Benedikt and Pedro L. Valls Pereira. "Speculative Bubbles and Contagion: Analysis of Volatility's Clusters during the Dotcom Bubble Based on the Dynamic Conditional Correlation Model." *Cogent Economics & Finance*, vol. 5, no. 1, Dec. 2017. EBSCOhost, doi:10.1080/23322039.2017.1411453.
- [19] Hull, Dana and Hannah Recht. (2018, May 3). Tesla Doesn't Burn Fuel, It Burns Cash. Retrieved July 14, 2018, from <https://www.bloomberg.com/graphics/2018-tesla-burns-cash/>.
- [20] Lee, Jack. "The Making of a Bubble: Tesla." *ToughNickel*, ToughNickel, 9 Apr. 2018, [toughnickel.com/personal-finance/The-Making-of-a-Bubble-TSLA](http://toughnickel.com/personal-finance/The-Making-of-a-Bubble-TSLA).
- [21] Leone, Vitor and Otavio Ribeiro de Medeiros. "Signalling the Dotcom Bubble: A Multiple Changes in Persistence Approach." *Quarterly Review of Economics & Finance*, vol. 55, Feb. 2015, pp. 77-86. EBSCOhost, doi:10.1016/j.qref.2014.08.006.
- [22] LoPucki, Lynn M. (n.d.). A window on the world of big-case bankruptcy. Retrieved October 19, 2018, from <http://lopucki.law.ucla.edu/>.
- [23] Mahajan, Vijay, Raji Srinivasan and Jerry Wind. (2002). The Dot.com Retail Failures of 2000: Were There Any Winners?. *Journal of The Academy of Marketing Science*, 30(4), 474-486.
- [24] Peavler, Rosemary. (2019, February 2). 3 Types of Business Bankruptcy. Retrieved from <https://www.thebalancesmb.com/what-is-business-bankruptcy-393017>.
- [25] "PETS.COM INC." *MergentOnline*, 2018.
- [26] Roberts, Lance. "Is The Dot-Com Bubble Back?" *Investing.com*, Fusion Media Ltd., 12 Mar. 2018, [www.investing.com/analysis/is-the-dotcom-bubble-back-200297363](http://www.investing.com/analysis/is-the-dotcom-bubble-back-200297363).
- [27] Staff, Investopedia. "Altman Z-Score." *Investopedia*, Investopedia, 17 May 2018, [www.investopedia.com/terms/a/altman.asp](http://www.investopedia.com/terms/a/altman.asp).
- [28] Varty, Anika. (2019, March 12). If You Had Invested Right After Tesla's IPO. Retrieved March 12, 2019, from <https://www.investopedia.com/articles/active-trading/081315/if-you-would-have-invested-right-after-teslas-ipo.asp>.
- [29] Wang, Ma-Ju and Heng Ruei (2014). Research on the common characteristics of firms in financial distress into bankruptcy or recovery. *Investment Management and Financial Innovations*, 11(4-1).
- [30] "Where Are They Now? 17 Dot-Com Bubble Companies And Their Founders." *Corporate Innovation Trends, CB Insights*, 14 Sept. 2016, [www.cbinsights.com/research/dot-com-bubble-companies/](http://www.cbinsights.com/research/dot-com-bubble-companies/).
- [31] Wright, Keith. (2018, May 22). Silicon Valley tech bubble is larger than it was in 2000, and the end is coming. Retrieved July 28, 2018, from <https://www.cnbc.com/2018/05/22/tech-bubble-is-larger-than-in-2000-and-the-end-is-coming.html>.

## **SARBANES-OXLEY ACT SECTION 302 TECHNOLOGY ISSUES AND AUDITOR EFFORT**

Anna J. Johnson-Snyder\*, East Carolina University, 312 Slay Hall/MS 503, Greenville, NC 27858, 252-737-1296, JohnsonAn18@ecu.edu

Brenda L. Killingsworth, 329 Slay Hall/MS 503, Greenville, NC 27858, 252-328-6235, killingsworthb@ecu.edu

### **ABSTRACT**

Changes in auditing standards have resulted in fluctuations in audit fees since the inception of the Sarbanes-Oxley (SOX) Act of 2002. Clients want a decrease in audit fee; however, a decrease in audit effort may not be likely as more entities delve deeper into the use of automation and technology, which also leads to a higher risk of having technology issues or cyber breaches. The purpose of this study is to examine the impact of SOX Section 302 No. 22, Technology Issues on audit effort.

### **INTRODUCTION**

Audit fees represents firm's audit rate multiplied the level of audit effort. Further audit fees have dramatically increased since the passage of the Sarbane-Oxley Act (SOX) of 2002 and the implementation of the Public Company Accounting Oversight Board (hereafter "Board" or "PCAOB") [5]. Intensified public and regulatory criticism have forced auditors to increase their effort, which has caused higher audit costs [16, p. 19]. Clients want a decrease in audit fee; however, a decrease in audit effort may not be likely as more entities delve deeper into the use of automation and technology, which also leads to a higher risk of having technology issues or cyber breaches.

The purpose of this study is to examine the impact of SOX Section 302 No. 22, Technology Issues (hereafter, IT issues), on audit effort. To our knowledge, no other research examines the effect of specific SEC 302 IT issues on auditor effort in the AS5 environment. The remainder of this article is organized as follows. In the next section, the literature review is presented while hypothesis development is discussed in the third section. Research design and empirical proxies are described in the fourth section. Sample data and descriptive statistics are assessed in the fifth section, and the results are discussed in the sixth section. The conclusion, limitations, and future research topics are presented in the final section.

### **THE ISSUE**

The importance and related challenges of developing a cybersecurity defense has been forced into the spotlight by the many data breaches [6][23][26]. It's been estimated that the related cost was \$4 million in 2019 and is continuing to grow [10]. In addition, these trends have increased emphasis on the importance of auditors understanding of the impact of these breaches on internal controls, their work load, and knowledge required to evaluate the weaknesses in internal control [11][14][15][21].

On June 30, 2002, the Sarbanes-Oxley (SOX) Act of 2002 was signed into law and created the PCAOB. Section 302 requires companies' management to disclose and report on internal control weaknesses and processes put into place to correct the issues [25]. Compliance with Section 302 was made more difficult because of Auditing Standard No. 2 (hereafter "AS2") requirements that limited external auditors' ability to rely on the work of other professionals [12]. AS2 was criticized for drastically increasing the workload required to be regulatory compliant [12]. Hence, Auditing Standard No. 5 (hereafter "AS5") was passed in 2005, allowing auditors to rely on other's work if it met specific criteria [12][19].

Simunic [22] argues that auditing (actual auditor effort) is an economic good for the issuer in that the quantity demanded is based on a cost-to-benefit ratio. Theoretically, audit fees are equivalent to the efficient use of an issuer and firm's input and output resources needed to perform the audit. Therefore, assuming audit prices (i.e., rates) are constant, cross-sectional differences in fees are the result of changes in audit service quantity or auditor effort (hereafter effort or audit effort).

Actual auditor effort is an unobservable auditor input [7][22]. However, according to the audit pricing literature, auditor effort can be determined using audit firm and client characteristics and legal environment factors [1][3][17]. One area of interest to the issuer's management and auditors that increases auditor effort is internal control weaknesses. The heightened difficulty increases the likelihood of auditor resignations [2]. The higher planned effort results from an increase in client risk and audit complexity. In this study, we assume that the audit has been adequately planned and control for other issuer factors associated with client risk and audit complexity.

Krishnan, Krishnan, and Song's [13] (hereafter KKS) model examines the effect of AS5 on audit fees by using "clean" (without a weakness disclosure) and "non-clean" (with a weakness disclosure) industry-level matched firms across a three year period. , The authors hypothesize and find that firms reporting weaknesses in both the AS2 and AS5 period had a decrease in overall audit fee in the latter period.

This paper examines whether a disclosure of an technology related internal control is associated with an increase in audit effort. Consistent with the Simunic [22] and Francis and Wang (hereafter FW) [4] arguments, an unexpected increase in the quantity of audit services, holding unit cost constant, will result in an increase in the audit fee. Further, an increase in service quantity is not related to an increase in higher-expert labor, i.e., higher billing rates, but an increase in higher staff audit labor, i.e., more hours [20]. Thus, in this study, audit effort is best represented by total audit fees.

H1: Audit effort, as proxied by audit fees, will not change in the period specific Section 302 client issues are reported [Stated in the null format].

## **RESEARCH DESIGN**

To test the hypothesis, we estimate the following regression equation adapted from the FW [4] and KKS [13] model:

$$\begin{aligned}
\Delta LAF = & \lambda_0 + \beta_1 \Delta LASSET + \beta_2 \Delta EBIT + \beta_3 \Delta |ACCR| + \beta_4 \Delta RECINV \\
& + \beta_5 \Delta LIQ + \beta_6 \Delta CATA + \beta_7 \Delta MERGER + \beta_8 \Delta FOREIGN \\
& + \beta_9 \Delta LEV + \beta_{10} \Delta ROA + \beta_{11} \Delta LNNAF + \beta_{12} \Delta ROA\_NEG \\
& + \beta_{13} \Delta LOSS + \beta_{14} \Delta RESTRUCT + \beta_{15} \Delta RESTATE + \beta_{16} \Delta GC \\
& + \beta_{17} \Delta SWITCH + \beta_{18} \Delta BIG4 + \lambda_1 \Delta INDUSTRY + \lambda_2 \Delta SEC302 + \varepsilon
\end{aligned} \tag{1}$$

Similar to the prior studies, we implement a number of controls for client and audit firm characteristics. Of the 20 variables in Equation (1), twelve were used in the FW [4] study and seven were added to the model by KKS [13]. Hoitash, Hoitash, and Bedard [8] examine internal control quality and audit pricing using SOX sections 302 and 404 disclosures. Hence, we added four additional variables, which are LNNAF, RESTATE, SWITCH, and LIT. To assess whether findings increase audit effort, we added one additional variable, which is the variable of interest or SEC302. The description of model variables is presented in Appendix A.

Generally, there are a number of variables associated with client features that influence the audit fees. Large clients (LASSETS) have more complex audits (|ACCR|, RECINV, MERGER, FOREIGN and SEG) and higher business risk (LIQ, CATA, LEV, ROA, ROA\_NEG, LOSS, RESTRUCTURE, RESTATE, GC, and LIT) that increases the audit effort and fees [4][9][13][18][22]. Some PCAOB inspection reports mention findings that result in issuer restatements (RESTATE). Hence, RESTATE has been included as an issuer control variable.

FW [4] find that audit fees are impacted for two-subsequent periods. Therefore, the data analysis period has been extended to a four-year period, 2008 through 2011. An increase in audit effort associated with an IT incident that happened in 2010 may have been included in calculating the 2010, 2011, and 2012 audit prices for December 31st fiscal year-end issuers (hereafter referred to as “year-end” issuers).

## SAMPLE DATA

To simplify the analysis and to isolate the impact of the negative surprise information, issuers' data had to meet several specific requirements: (1) is a publicly-traded company and (2) have data available in Compustat and Audit Analytics (Refer to Table 1). As in prior research studies, we removed observations of financial institutions (SICs between 6000 and 6999) and utilities (SICs between 4400 and 5000) [4]. We randomly chose to perform the analyses on KPMG clients, which contained 2,225 observations after data was merged (Refer to Table 1). Any client that was missing data were removed from the sample (49 observations). The sample used for analyses contains 470 unique firms with 3,290 firm-years.

**Table 1: Sample Selection Procedure**

<u>Description</u>	<u>Observations</u>
Compustat data (2008-2014)	4315
Audit Analytics (2008-2015)	3,826
Sections 302 and 404 KPMG clients (2008-2014)	2,857
PCAOB Inspection Report Findings (2008-2014)	107

Merge Sections 302 and 404, PCAOB inspection report data, and KPMG Compustat databases (keep only matched) (2008-2014)	3,809
Less: Observations lacking financial and audit fee data	(519)
Final sample	3,290 firm-year
Unique Number of firms (2008-2011)	470 firms

Descriptive statistics are presented in Table 2. The mean (standard deviation) of issuers' audit fees, total assets, absolute accruals, receivables plus inventory, current ratio, leverage, and return on asset are presented by year. During our analysis period, KPMG clients in our sample paid an average of \$3.58 to \$6.36 million in audit fees and had total assets between \$278.16 and \$693.99 million. The skewed data is corrected through log transformation prior to conducting the analysis.

**Table 2: Descriptive Statistics**

Variables	2008		2009		2010		2011	
	Mean	Std. Dev.	Mean	Std. Dev.	Mean	Std. Dev.	Mean	Std. Dev.
TAF	\$3.765	\$4.675	\$3.583	\$4.554	\$3.726	\$5.037	\$3.991	\$5.504
LAF	14.493	0.924	14.437	0.904	14.432	0.908	14.491	0.897
LNAF	12.438	1.632	12.466	1.605	12.627	1.543	12.633	1.692
TASSETS	\$632.039	\$295.003	\$636.507	\$284.744	\$623.673	\$278.158	\$630.675	\$288.156
LASSET	7.196	1.55	7.195	1.557	7.230	1.535	7.338	1.540
EBIT	0.078	0.204	0.059	0.338	0.061	0.107	0.081	0.106
ACCR	0.078	0.299	0.117	0.193	0.0986	0.115	0.061	0.0637
RECINV	0.267	0.166	0.277	0.177	0.2685	0.167	0.250	0.150
LIQ	2.795	5.875	2.911	6.556	2.898	3.789	2.726	2.985
CATA	0.435	0.210	0.500	0.301	0.460	0.210	0.432	0.213
LEV	0.505	0.240	0.538	0.2823	0.508	0.258	0.509	0.246
ROA	2.344	37.344	-3.226	37.706	1.436	13.830	3.707	11.496

Variables	2012		2013		2014	
	Mean	Std. Dev.	Mean	Std. Dev.	Mean	Std. Dev.
TAF	\$4.280	\$5.725	\$4.565	\$5.811	\$4.852	\$6.356
LAF	14.571	0.888	14.677	0.875	14.748	0.839
LNAF	12.781	1.626	12.726	1.677	12.716	1.760
TASSETS	\$649.267	\$297.313	\$672.057	\$302.528	\$693.990	\$306.860
LASSET	7.443	1.539	7.535	1.539	7.619	1.533
EBIT	0.081	0.133	0.073	0.147	0.0724	0.115
ACCR	0.058	0.0783	0.066	0.076	0.060	0.076
RECINV	0.256	0.155	0.258	0.153	0.257	0.155
LIQ	2.713	3.160	2.526	1.815	2.533	1.683
CATA	0.441	0.212	0.432	0.208	0.421	0.195
LEV	0.524	0.243	0.533	0.235	0.530	0.234
ROA	3.886	12.428	2.505	15.194	3.023	14.979

TAF is the total audit fees in millions of dollars.

LAF is the natural log of audit fees.

LNAF is the natural log of non-audit fees.

TASSETS is the total book value of assets in millions of dollars.

LASSET is the natural log of total assets.

EBIT is the ratio of earnings before interest and tax to total assets.

|ACCR| is the absolute value of the ratio of total accruals to total assets where accruals are defined as income before extraordinary items minus operating cash flows from the statement of cash flows.

RECINV is the sum of receivables and inventory to total assets.

CATA is the ratio of current assets to total assets.

CATA is the ratio of current assets to total assets.

LEV is leverage or total liabilities to total assets.

ROA is the ration of income before extraordinary items to total assets.

## RESULTS

We used ordinary least squares (OLS) regression models to conduct the analyses of the 2008 to 2010 periods (i.e., models 1 to 8; refer to Table 3). Although the explanatory power for the models assessing audit effort varies (R-squares between 0.101 and 0.647), each of the models are statistically significant. However, we do not find results similar to prior research papers.

In the hypothesis, we tested whether audit effort will change in the period the Section 302 disclosures for IT issues are reported and do not find results. In hypothesis two, we test whether the cost of audit effort associated with Section 302 disclosures for IT issues in a subsequent year. Again, we do not find results. We believe that the lack of results, overall, may be attributable to an omitted variable. We are going to hand collect the data for a specific variable that we believe may be an omitted variable and resubmit the updated paper prior to the conference date.

**Table 3. Regression Results for Impact of PCAOB Findings on Audit Fee (Accounting)**

	(1)		(2)	
	2008 to 2009		2008 to 2010	
<b>Controls for 2<sup>nd</sup> Year</b>	B	t-value	B	t-value
ΔLAF_2008to2009			0.847	20.193***
ΔLAF_2009to2010				
<b>Variables for 1<sup>st</sup> Year</b>				
ΔLASSET	0.033	2.600**	0.023	0.806
ΔEBIT	0.082	2.813**	0.012	0.113
Δ ACCR	-0.243	-1.831*	0.108	0.912
ΔRECINV	0.175	0.940	-0.187	-1.133
MERGER	0.079	2.077**	-0.030	-0.886
FOREIGN	-	-	-	-
ΔLIQ	-0.005	-0.911	0.004	0.794
ΔCATA	-0.007	-0.111	0.039	0.681
ΔLEV	0.089	0.828	0.076	0.788
ΔROA	-0.002	-1.586	0.002	1.377
ΔLNAF	0.004	0.891	0.010	2.465**
ROA_NEG	-0.063	-1.514	-0.104	-2.827**
LOSS	0.072	1.421	0.114	2.521**
RESTRUCT	-0.039	-1.672*	-0.026	-1.257
RESTATE	-	-	-	-
GC	-0.006	-0.070	-0.046	-0.647
SWITCH	-	-	-	-
INDUSTRY	-0.001	-1.615*	0.000	-0.238
SEC302_IT	-0.012	-0.499	-0.023	-1.069
R-squared		0.101		0.545
Adjusted R-squared		0.057		0.522
F-value		2.285**		23.269***

## CONCLUSION



Although we do not find results in this paper that are consistent with theory and the results reported in prior research, we have performed additional analyses that suggests we have an omitted variable.

There are two limitations within the study. First, the Audit Analytic information related to the SOX Section 302 disclosures has inherent weaknesses. Audit clients are not consistent in the wording of internal control deficiencies and weaknesses in the SEC filings. Thus, the results related to issuer disclosures must be interpreted with caution. Second, the results of the study are not generalizable to a large issuer base or, potentially, other audit firms.

Future research projects may be to expand the current study to include other big-four firms, annual and triennially inspected firms, and non-December 31st fiscal year-end issuers.

### **APPENDIX A**

“ $\Delta$ ” represents the change in value across two fiscal years;

LAF is the natural log of audit fees in millions of dollars;

LNNAF is the natural log of non-audit fees in millions of dollars;

LASSETS is the natural log of total book value of assets in millions of dollars;

EBIT is the ratio of earnings before interest and tax to total assets;

|ACCR| is the absolute value of a ratio of total accruals to total assets where accruals are defined as income before extraordinary items minus operating cash flows from the statement of cash flow ;

RECINV is the sum of receivables and inventory to total assets;

MERGER is an indicator variable equal to 1 if the company has merged for any period, and 0 otherwise;

FOREIGN is the ratio of sales made by foreign subsidiaries to total sales;

LIQ is the ratio of current assets (less inventory) to current liabilities;

CATA is the ratio of current assets to total assets;

LEV is leverage or total liabilities to total assets;

ROA is the ratio of income before extraordinary items to total assets;

ROA\_NEG is an indicator variable equal to 1 if ROA is negative for any period, and 0 otherwise;

RESTRUCT is an indicator variable equal to 1 if “RCP or RCEPS” is present in the Compustat for any period, and 0 otherwise;

RESTATE is an indicator variable equal to 1 if the financial statements have been restated, and 0 otherwise;

SWITCH is an indicator variable equal to 1 if the client switched auditors for any period, and 0 otherwise;

GC is an indicator variable equal to 1 if the firm received a modified going-concern audit opinion for any period, and 0 otherwise ;

SWITCH is an indicator variable equal to 1 if the client switched auditors for any period, and 0 otherwise;

LOSS is an indicator variable equal to 1 if earnings before extraordinary items is less than 0, and 0 otherwise;

INDUSTRY an indicator variable that represents the industry fixed effects and is based on two-digit Standard Industry Classification (SIC) code; and SEC302 is an indicator variable equal to 1 if an internal control weakness related to technology (an accounting issue related to acquisitions) was disclosed by the issuer in the Section 302 report as an “IC” (“ACC”) issue, and 0 otherwise.

## REFERENCES

- [1] Choi, J. H., Kim, J. B., Liu, X., & Simunic, D. A. (2008). Audit pricing, legal liability regimes, and big 4 premiums: Theory and cross-country evidence. *Contemporary Accounting Research*, 25(1), 55–99.
- [2] Ettredge, M. L., Heintz, J., Li, C., & Scholz, S. (2011). Auditor realignments accompanying implementation of SOX 404 ICFR reporting requirements. *Accounting Horizons*, 25(1), 17–39.
- [3] Francis, J. R., Reichelt, K., & Wang, D. (2005). The pricing of national and city-specific reputations for industry expertise in the U.S. audit market. *The Accounting Review*, 80(1), 113–136.
- [4] Francis, J. R., & Wang, D. (2005). Impact of the SEC’s public fee disclosure requirement on subsequent period fees and implications for market efficiency. *Auditing: A Journal of Practice and Theory*, 24(Supplement), 145–160.
- [5] Ghosh, A., & Pawlewicz, R. (2009). The impact of regulation on auditor fees: Evidence from the Sarbanes-Oxley Act. *Auditing: A Journal of Practice and Theory*, 28(2), 171–197.
- [6] Haapamaki, E., & Sihvonen, J. (2019). Cybersecurity in accounting research. *Managerial Auditing Journal*, 34(7), 808–834.
- [7] Hay, D. C., Knechel, W. R., & Wong, N. (2006). Audit fees: A meta-analysis of the effect of supply and demand on attributes. *Contemporary Accounting Research*, 23(1), 141–191.
- [8] Higgs, J., & Skantz, T. (2006). Audit and nonaudit fees and the market’s reaction to earnings announcements. *Auditing: A Journal of Practice and Theory*, (May), 1–26.
- [9] Hoitash, R., Hoitash, U., & Bedard, J. C. (2008). Internal control quality and audit pricing under the Sarbanes-Oxley Act. *Auditing: A Journal of Practice and Theory*, 27(1), 105–126.
- [10] IBM. (2019). Cost of data breach study: Global study. Retrieved from <https://www.ibm.com/security/data-breach>
- [11] Islam, S., Farah, N., & Stafford, T. F. (2018). Factors associated with security/cybersecurity audit by internal audit function: an international study. *Managerial Auditing Journal*, 33(4), 377–409.
- [12] Jiang, W., & Wu, J. (2009). The impact of PCAOB Auditing Standard 5 on audit fees. *The CPA Journal*, 79(4), 34–38.
- [13] Krishnan, J., Krishnan, J., & Song, H. (2011). The effect of auditing standard No. 5 on audit fees. *Auditing: A Journal of Practice and Theory*, 30(4), 1–27.
- [14] Li, H., No, W. G., & Boritz, E. (2019). Are external auditors concerned about cyber incidents? Evidence from audit fees (Forthcoming). *Auditing: A Journal of Practice & Theory*. Retrieved from <https://aaajournals.org/doi/pdf/10.2308/ajpt-52593>
- [15] Li, H., No, W. G., & Wang, T. (2018). SEC’s cybersecurity disclosure guidance and disclosed cybersecurity risk factors. *International Journal of Accounting Information Systems*, 30, 40–55.

- [16] Murphy, M. L. (2014). A fresh approach to regulation and audit quality: An interview with PCAOB board member Jay D. Hanson. *The CPA Journal*, 84(4), 15–23.
- [17] Pae, S., & Yoo, S. W. (2001). Strategic interaction in auditing: An analysis of auditors' legal liability, internal control system quality, and audit effort. *The Accounting Review*, 76(3), 333–356.
- [18] Palmrose, Z. V. (1986). Audit fees and auditor size: Further evidence. *Journal of Accounting Research*, 24(1), 97–110.
- [19] Public Company Accounting Oversight Board. (2007a). Auditing Standard No. 5: An audit of internal control over financial reporting that is integrated with an audit of financial statements (PCAOB Release No. 2007-005A). Retrieved June 11, 2014, from Public Company Accounting Oversight Board (PCAOB) website:  
[http://pcaobus.org/Standards/Auditing/Pages/Auditing\\_Standard\\_5.aspx](http://pcaobus.org/Standards/Auditing/Pages/Auditing_Standard_5.aspx)
- [20] Redmayne, N. B., Bradbury, M. E., & Cahan, S. F. (2010). The effect of political visibility on audit effort and audit pricing. *Accounting and Finance*, 50, 921–939.
- [21] Rosati, P., Gogollin, F., & Lynn, T. (2019). Audit firm assessments of cyber-security risk: Evidence from audit fees and SEC comment letters. *The International Journal of Accounting*, 54(3), 1950013.
- [22] Simunic, D. A. (1980). The pricing of audit services: Theory and evidence. *Journal of Accounting Research*, 18(1), 161–190.
- [23] Spanos, G. A. (2016). The impact of information security events to the stock market: A systematic literature review. *Computers and Security*, 58, 216–229.
- [24] Thoman, L. (1996). Legal damages and auditor efforts. *Contemporary Accounting Research*, 13(1), 275–306.
- [25] U.S. House of Representatives. Sarbanes-Oxley Act (SOX) of 2002. , Pub. L. No. 745 (2002).
- [26] Yen, J., Lim, J., Wang, T., & Hsu, C. (2018). The impact of audit firms' characteristics on audit fees following information security breaches. *Journal of Accounting and Public Policy*, 37, 489–507.
- [27] Yen, Ju-Chun, Lim, Jee-Hae, Wang, Tawei, and Hsu, Carol. 2018. The impact of audit firms' characteristics on audit fees following information security breaches. *Journal of Accounting and Public Policy*, Vol. 37, pp. 489-507

## **TECHNOLOGY INNOVATION AND HEALTHCARE IN ISRAEL: THE EFFECT OF INTERNATIONAL COOPERATION PATENTS ON HEALTHCARE EXPENDITURES**

Xiaohui You, James Madison University, Harrisonburg, VA, 540-746-2956,  
youxx@jmu.edu

Albert A. Okunade, The University of Memphis, Memphis, TN, (901) 678-4563,  
aokunade@memphis.edu

### **ABSTRACT**

Israel has been ranked as the top healthiest country in the world for years, with high standards of health services, high-quality medical research, and a high ratio of physicians. Meanwhile, high-tech services contribute significant and immediate improvements in the quality and safety of health care. Israel takes advantage of a lucrative “health technology tsunami”, creates partnerships with European and US, gain a global competitive edge via innovation, and Israeli innovation goes global via the partnership cooperation. This study specifies and econometrically estimates the Autoregressive Distributed Lag Cointegration (ARDL) model of health care expenditures in Israel, using the 1980-2017 time-series data, with income (GDP) and technology (International Cooperation patents) are the two major drivers, along with the age dependency ratio and physicians. ARDL bounds test for cointegration and Granger causality test for the causal link are applied. Empirical results suggest that there is a long-run relationship among the healthcare expenditures, patents, physician, and aging ratio. The increase of international cooperation patents is positively affecting the growth rate of the healthcare expenditures (HCE), however, the effect of patents from residences on HCE is negative; while the effects are fluctuating from year to year as patents could conceivably reduce the health spending if new patented medical products turn out to be cheaper than existing interventions. As always, income (GDP) is the main driver of the growth of health care expenditures, as well as the impressive ratio of physicians and the significantly higher effect of aging ratio.

### **JEL Codes: I1**

**Keywords:** Healthcare expenditures; Technology innovation; Patents; ARDL; International cooperation

## **TECHNOLOGY INNOVATION AND HEALTHCARE IN ISRAEL: THE EFFECT OF INTERNATIONAL COOPERATION PATENTS ON HEALTHCARE EXPENDITURES**

### **I. Introduction**

Israel has been ranked as the top healthiest country in the world for years, with high standards of health services, high-quality medical research, and a high ratio of physicians. Being a small country with less than 9 million citizens, Israel has a modern market-based economy with a comparable level of gross domestic product (GDP) per capita to the average of Organization for Economic Cooperation and Development (OECD) countries, and universal health coverage based on the National Health Insurance (NHI) Law of 1995. Under the introduction of a progressively financed statutory health insurance system, all citizens resident in the country can choose from among four competing, non-profit-making health plans, which are charged with providing a broad package of benefits stipulated by the government. This made Israel health care system quite efficient, that health status levels are comparable to those of other developed countries though Israel spends a relatively low proportion of its gross domestic product on health care. Only 62% of health expenditures were publicly financed, a share that is one of the lowest among OECD countries in 2015. Israeli health care has also demonstrated a remarkable capacity to innovate, improve, establish goals, be tenacious and prioritize [23]. Health technology innovation is among several main factors that contribute to healthcare efficiency, such as the well-developed system of electronic health records and the global cooperation of medical technology companies. National projects have been launched to measure and improve the quality of healthcare, greater public dissemination of comparative performance data, and address projected shortages of physicians and nurses [23].

The rising aging ratio to the population is placing much strain on health services worldwide. Interestingly, Israel's population is considered young compared to other Western countries. With aged 65 and over is about 10% and aged 75 and over is 4% of the country's population, Israel is a young country by western standards according to World Population Ageing 2015. In 2010, 28% of Israel's population was aged between 0-14, compared to 17% in other Western countries, and about 10% were aged above 65%, compared to 15% in Western countries [27].

High-tech services contribute significant and immediate improvements in the quality and safety of health care. Israel is a global leader in the digital health sector, the country takes advantage of a lucrative "health technology tsunami", creates partnerships with European and US, gain a global competitive edge via innovation, and Israeli innovation goes global via the partnership cooperation. As [4] states that there is virtually no area of medicine to which Israeli devices have not made significant contributions - cardiology, genetics, neurology, and ophthalmology are but a few of the sciences benefiting from advanced Israeli technology. Scientists, universities, and companies in Israel are working to benefit the global health system - from physician to patient to medical administrators and insurers. Since the beginning of the 1990s, Israel has become a prime site for international venture capital and technology-seeking funds, despite the insurmountable odds, such as distance, language, cultural differences, and fluctuations in the continuing peace process.

The purpose of this study is to investigate if there is a long-run relationship among healthcare expenditures, income (GDP) and technology (International Cooperation patents and the application of residency patents), the two major drivers of healthcare expenditures, and the age

dependency ratio and physicians. To capture this complex relationship for an empirical investigation, we employ the Autoregressive Distributed Lag Cointegration (ARDL) approach with the 1980-2017 time-series data. ARDL bounds tests and Granger causality tests are applied to estimate the cointegration and causality relationship among these variables.

The rest of the paper proceeds as follows. Section II is the literature review, Section III discusses the methodology and presents the empirical models. Section IV describes the data and variables used in this study, and Section V focuses on the empirical results. Finally, Section VI concludes the findings of this research.

## **II. Literature Review**

High-tech services contribute significant and immediate improvements in the quality and safety of Israel health care. New medical technologies significantly increase healthcare expenditures in Israel. Each year, the Israel government estimates the costs of new technologies recommended as high-priority for public funding were summarized. According to [22], funding the new medical technologies would increase healthcare expenditures by 2.1% and the government allocations for new technologies would raise healthcare expenditures by 1% per year.

Previous literature confirms the roles of real per-capita income (demand side) and technology (supply side), as the major factors on driving up healthcare expenditures ([14] [19, pp. 671-687] [13, pp. 279-285] [29, pp. 1023-1029] [16, pp. 147-159] [2, pp. 645-680] [28, pp. 263-272] [24, pp. 223] [30, pp. 853-862] [17, pp. 327-358]. Measuring healthcare and medical technology can be difficult since there are a variety of measurements, such as new drugs, medical devices, information technology, digital technology, Electronic Health Records (EHR)...etc. Using technology proxy variables to measure the technology effect is an effective approach to capture the relationship between technology and healthcare expenditures [13] [30, pp. 853-862] [17, pp. 327-358].

[9] states that Israel has long been renowned as a hub for high-tech innovation, with an active investment scene and spinout-friendly research centers helping to push the country's MedTech sector to new heights. As Israel's domestic market is small, the country has always styled itself as an innovation hub for the world. This, of course, brings challenges for small Israeli companies looking to secure regulatory approval from multiple authorities globally and compete against much larger international rivals.

[5] and [17, pp. 327-358] use the number of international co-operation in patents as a novel technology proxy to estimate the technological effect on healthcare expenditures. Patents are a key measure of innovative output because patent indicators reflect the inventive performance of countries, regions, technologies, firms...etc. [6]. Patents are also used to track the level of knowledge diffusion across technology areas, countries, sectors, firms, etc., and the level of internationalization of innovative activities [15].

Therefore, following the insightful justification in a most recent work [5] and [17, pp. 327-358], we use both the international cooperation on patents and the applications of patents made by residency as proxies for technology. Using time-series data or panel data ARDL cointegration

methods, previous researches estimated income and technology effects on healthcare expenditures for a county [12] or country groups, notably, the OECD [26] [8, pp. 153-162], ASEAN-5 [25], 26 Asian countries [11], and 36 Asian countries [1]. In this study, we address the long-run cointegration relationship among healthcare expenditures, GDP, technology, aging ratio, as well as the physician number, using ARDL model with the latest available 1980-2017 time-series data in Israel.

### III. Methodology

We explain here our econometric methodology for estimating the healthcare expenditure model. The pronounced Cobb Douglas function in the shape of the natural logarithm format model of healthcare expenditures (HCE) is following as under:

$$HCE_t = \beta_0 + \beta_1 GDP_t + \beta_2 AGE_t + \beta_3 PHYS_t + \beta_4 PATENT_t + \varepsilon_t \quad (1)$$

where  $\beta_0$  is a constant term and  $\beta_n$  is estimated parameters in the model, the elasticities of real health expenditure with respect to the GDP (income), AGE (age ratio), PHYS (Physician per 1000), and PATENT (International co-operation patents or patent applications by residency) at year  $t$  with time series, and  $\varepsilon_t$  is the error term.

Comparing with the conventional cointegration techniques, the ARDL (Autoregressive Distributed Lag model) bounds testing approach [20] [21, pp. 289–326] has several advantages on estimating the long-run relationship between the variables. It can be used regardless of the orders of integration of variables; it estimates the short- and the long-run components simultaneously; and corrects the problem of endogeneity and provides unbiased estimates. The empirical formulation of ARDL equation is specified as follows,

$$\Delta HCE_t = \beta_0 + \beta_1 T + \beta_2 D + \beta_3 HCE_{t-1} + \beta_4 GDP_{t-1} + \beta_5 AGE_{t-1} + \beta_6 PHYS_{t-1} + \beta_7 PATENT_{t-1} + \sum_{g=1}^s \beta_8 HCE_{t-g} + \sum_{h=1}^p \beta_9 GDP_{t-h} + \sum_{i=1}^q \beta_{10} AGE_{t-i} + \sum_{j=1}^m \beta_{11} PHYS_{t-j} + \sum_{k=1}^n \beta_{12} PATENT_{t-k} + \varepsilon_t \quad (2)$$

$$\Delta X_t = \beta_0 + \beta_1 T + \beta_2 D + \beta_3 HCE_{t-1} + \beta_4 GDP_{t-1} + \beta_5 AGE_{t-1} + \beta_6 PHYS_{t-1} + \beta_7 PATENT_{t-1} + \sum_{g=1}^s \beta_8 HCE_{t-g} + \sum_{h=1}^p \beta_9 GDP_{t-h} + \sum_{i=1}^q \beta_{10} AGE_{t-i} + \sum_{j=1}^m \beta_{11} PHYS_{t-j} + \sum_{k=1}^n \beta_{12} PATENT_{t-k} + \varepsilon_t \quad (3)$$

Where  $\Delta$  is the difference operator,  $T$  is the time trend,  $D$  is a dummy variable, which can capture the structural break arising from the time series.  $X$  is GDP, AGE, PHYS, and PATENT, respectively, and the disturbance term,  $\varepsilon_t$ . To check the cointegrating relationship among those variables, we use the F-test for the joint significance of the coefficients of the lagged variables with the null hypothesis,  $H_0: \beta_3 = \beta_4 = \beta_5 = \beta_6 = \beta_7$  indicating no cointegration. As [21] suggests, F statistics are computed to compare the upper and lower bounds critical values.

The unrestricted error-correction model (ECM) is as following:

$$\Delta HCE_t = \phi ECT_{t-1} + \sum_{i=1}^{n-1} \lambda_i \Delta HCE_{t-1} + \sum_{j=0}^{n-1} \lambda_2 \Delta GDP_{t-1} + \sum_{j=0}^{n-1} \lambda_3 \Delta AGE_{t-1} + \sum_{j=0}^{n-1} \lambda_4 \Delta PHYS_{t-1} + \sum_{j=0}^{n-1} \lambda_5 \Delta PATENT_{t-1} + v_t \quad (4)$$

where  $ECT$  is the error correction term and  $\lambda$  is the speed of adjustment parameter.

## Two Models

We have two models in this study regarding the variable, PATENT, the technology proxy. One uses the international cooperation patents as the technology proxy, PATENT1, the other uses patents application by residency as the proxy, PATENT2.

Dependent Variable, HCE:

Model 1 with independent variables: GDP, LAGE, PHYS, COPAT (PATENT1)

Model 2 with independent variables: GDP, LAGE, PHYS, PATENTR (PATENT2)

**Table 1: Descriptive statistics of the data**

Description	Expenditure on health care, per capita, constant prices	Gross domestic product per capita, at constant prices	Old (>65 yrs.) to total population ratio	Physicians (per 1,000 people)	Number of international co-operation on patents	Number of patent applications, residents
<b>Data coverage</b>	1980-2017	1980-2017	1980-2017	1980-2017	1980-2016	1980-2015
<b>Variables</b>	HCE_PER <sup>1</sup>	GDP_PER <sup>2</sup>	AGER <sup>2</sup>	PHYS1000 <sup>1</sup>	COPAT_RAW <sup>1</sup>	PATENTAP_R <sup>2</sup>
<b>(Var. Label with log)</b>	HCE	GDP	AGE	PHYS	COPAT	PATENTR
Mean	1650.896	25461.28	9.754996	3.916053	849.3514	1228.194
Median	1687.160	26100.12	9.923590	4.120000	399	1263.5
Maximum	2378.618	34134.81	11.73329	4.300000	2793	2053
Minimum	1071.499	17555.37	8.604196	3.140000	22	669
Std. Dev.	397.3220	5102.555	0.870711	0.380373	914.1644	345.2345
Skewness	0.136048	0.013979	0.311021	-0.885361	0.957466	0.159855
Kurtosis	1.861412	1.784545	2.332581	2.041748	2.58259	2.764275
Jarque-Bera	2.169827	2.340346	1.317941	6.418362	5.921842	0.23667
Probability	0.337931	0.310313	0.517384	0.040390	0.051771	0.888398
Obs	38	38	38	38	37	36

Note: Data sources

1. OECD.Stat.

2. World Development Indicators\_ The world bank IBRD-IDA



Figure 1: The trend series of the individual variables

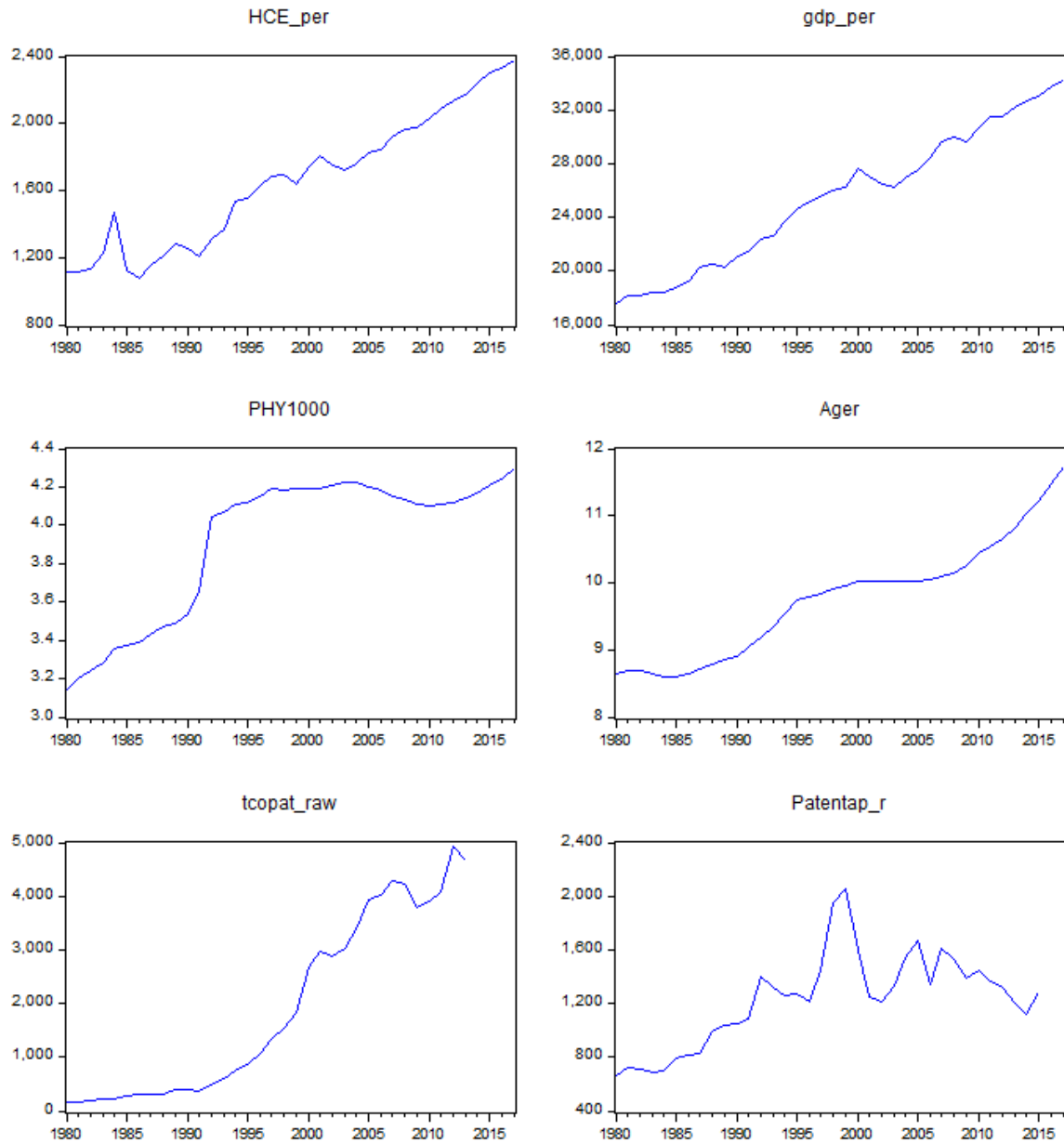

#### IV. Data and Variables

This study uses annual time series data in Israel from 1980 to 2017 ( $T = 38$ ) for health expenditure per capita (constant price), Gross Domestic Product per capita (at constant prices), Old (>65 years) to total population ratio, and Physicians per 1,000 people, 1980-2016 ( $T = 37$ ) for the number of

International Co-operation on patents and 1980-2015 (T =36) for the number of patent applications made by residents. Our data are collected from two sources: OECD.Stat. [15] and the World Development Indicators: The world bank IBRD-IDA.

Table 1 presents the descriptive statistics, where minimum, maximum, standard deviation, skewness, kurtosis, and Jerqa-Bera test values are showing their properties. According to the skewness and kurtosis values portrayed in Table 1, the data have no problem of skewness or kurtosis issue. Jerqa-Bera value for all variables is insignificant (PHYS insignificant at 90% level), which indicates that all variables are normally distributed. All variables are transformed into natural logarithms for estimation.

Figure 2: The movement pattern of the individual variables (after taking natural log)

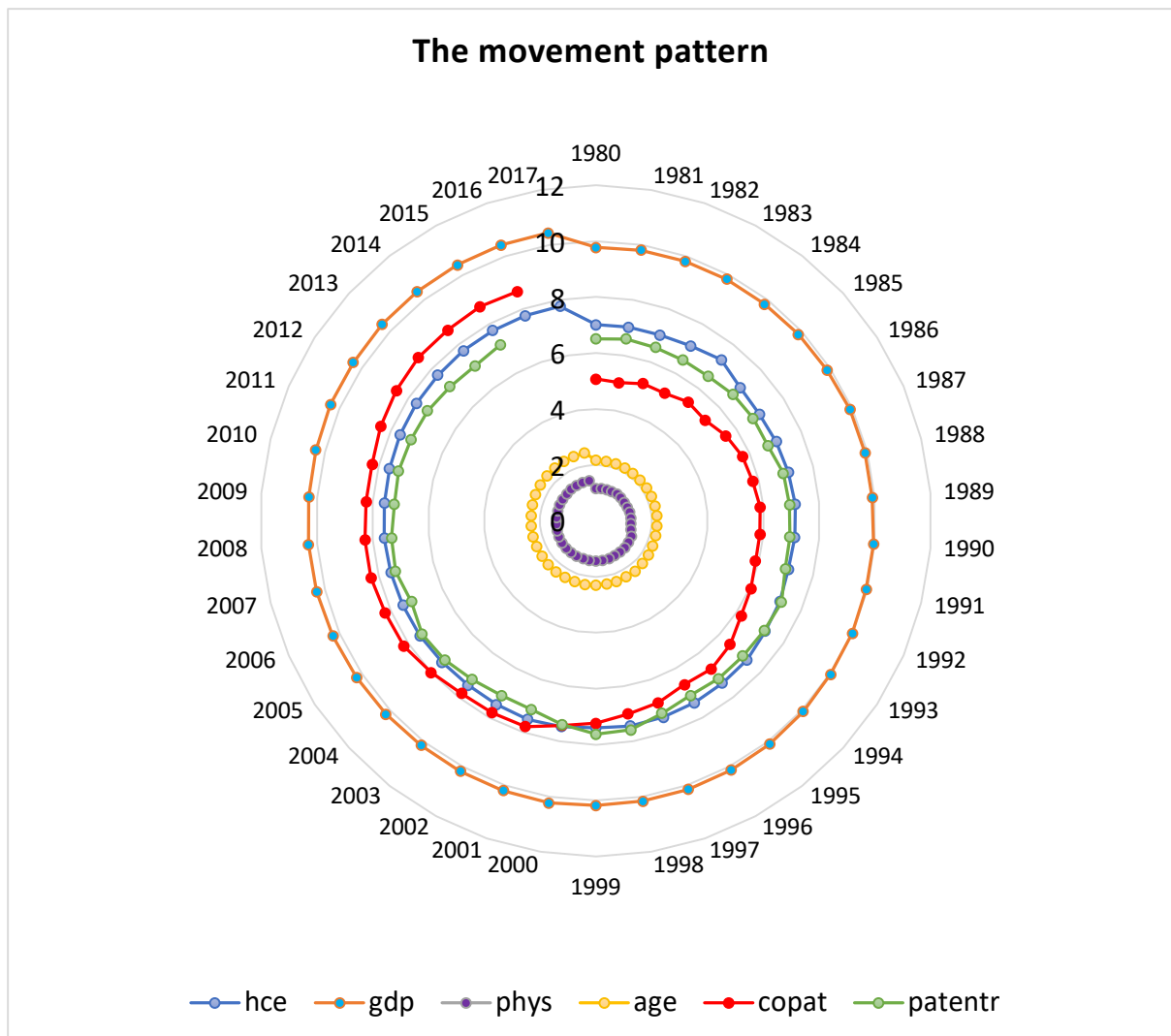

Figure 1 is displaying the trend of the time series for all variables (raw data). According to the graphs, there are bearing upward trend for all variables from 1980-2017. Hence, taking a logarithm will be a good approach for detrending. After taking a natural log with the variables, the dynamic movement of the individual series exhibits a consistent pattern as shown in Figure 2: The movement pattern of the individual variables (after taking natural log), which illustrates the common trend with the simulated data -an evidence of cointegration relationship.

## V. Empirical Results

Using annual time series data in Israel from 1980 to 2017, we examine the long- and short-run relationships among HCE, GDP, AGE, PHYS, and PATENT (COPAT for Model 1 and PATENTR for Model 2).

### Results from Unit Root estimations

Beginning with the unit root tests, the preliminary phase of the proper investigation is to gauge the stationarity level of the individual variable, either it is stationary at the level, first difference or second difference. The level of stationary guided further methodology selection for estimation that recommended policy implication for the future. The most prominent unit root test Augmented Dickey-Fuller (ADF) that was pioneered by [3] have been utilized to gauge the level of stationarity for regressors and regressed variable in Table 2. This identification pursues a level of cointegration among the variable via employing an appropriate econometric technique for result extraction.

**Table 2: Results from Unit Root Tests-ADF**

Variable (label)	Level		First difference	
	without trend	with trend	without trend	with trend
HCE	-0.693	-3.603**	-6.719***	-6.619***
GDP	-0.849	-1.894	-5.755***	-5.693***
AGE	0.721	-2.626	-3.155**	-1.779
PHYS	-2.446	-1.226	-4.094***	-4.318***
COPAT	-1.636	-1.350	-6.247***	-6.586***
PATENTR	-2.023	-1.662	-4.875***	-4.908***

Test significance:                   \*\*\*at 1% level  
    \*\* at 5% level  
    \* at 10% level

**Table 3: Results from Granger Causality tests**

<b>Model 1</b>	<b>Model 2</b>
GDP =>HCE	GDP =>HCE
AGE =>HCE	AGE =>HCE
PHYS -HCE	PHYS -HCE
COPAT -HCE	PATENTR -HCE
AGE -GDP	AGE -GDP
PHYS -GDP	PHYS -GDP
COPAT =>GDP	PATENTR =>GDP
PHYS=>AGE	PHYS =>AGE
COPAT -AGE	PATENTR -AGE
COPAT -PHYS	PATENTR -PHYS

Note: "-" means "no causality"; "A => B" means "A granger cause B"; "A <=> B" means "A and B granger cause each other".

### Results from Granger Causality tests

Robustness of the estimations has been determined through the pairwise Granger causality test [7], which elaborates the directional linkages between the two variables at a time. As the Granger Causality tests results suggest, GDP, AGE, and PHYS causally influence the HCE, meanwhile, COPAT causes GDP, PATENTR causes GDP, and PHYS causes AGE. The result shows that there is a unidirectional causality among the independent variables and the HCE, and among those variables as well. Meanwhile, there is no Granger causality has been found with HCE, the dependent variable.

### Results for VAR Lag Order Selection Criteria

Since ARDL is sensitive to lag order, for calculating the F statistic, first of all, we need to identify the appropriate lag order. To do this, we choose AIC (Akaike Information Criterion) as it provides better results than other lag length criteria [10]. Results for VAR lag order selection criteria (Table 4\_1 and 4\_2) suggest the fourth lag for both Model 1 and Model 2. Further, confirmation for lags selection under the VAR model has been determined in Figure 3\_1 for model 1 and Figure 3\_2 for model 2 (See, Appendix). Since the Polynomial graph where all blue dots are within the circle, lags 4 would be appropriate for both models.

**Table 4\_1: Results for VAR Lag Order Selection Criteria (Model 1)**

Lag	LogL	LR	FPE	AIC	SC	HQ
0	171.8182	NA	6.94e-12	-11.5047	-11.26896	-11.43087
1	290.5598	188.3488	1.11e-14	-17.96964	-16.5552	-17.52666
2	328.5294	47.13460	5.39e-15	-18.8641	-16.27095	-18.05195
3	373.6196	40.42568*	2.21e-15	-20.24962	-16.47777	-19.06833
4	434.9476	33.83615	6.16e-16*	-22.75501*	-17.80445*	-21.20455*

**Table 4\_2: Results for VAR Lag Order Selection Criteria (Model 2)**

Lag	LogL	LR	FPE	AIC	SC	HQ
0	190.8368	NA	1.87e-12	-12.81633	-12.58059	-12.7425
1	293.7013	163.1644	8.97e-15	-18.1863	-16.77186*	-17.74331
2	327.0448	41.39186*	5.97e-15*	-18.76171	-16.16856	-17.94957
3	353.9908	24.15846	8.54e-15	-18.89591	-15.12406	-17.71462
4	401.1600	26.02441	6.34e-15	-20.42483*	-15.47427	-18.87438*

\* indicates lag order selected by the criterion

LR: sequential modified LR test statistic (each test at 5% level)

FPE: Final prediction error

AIC: Akaike information criterion

SC: Schwarz information criterion

HQ: Hannan-Quinn information criterion

### **Bounds test on Long-run Coefficients in the Unrestricted ECM**

Table 5 represents the bounds test on long-run coefficients in the unrestricted ECM for testing the existence of level relationships for both model 1 and model 2. The results suggest that income (GDP), aging, physician, and patents for both model 1 and model 2 are moving together with healthcare expenditures in the long run though there might be deviations that occur in the short

run. In addition, the existence of a cointegration relationship may also imply that the independent variables are correctly specified.

**Table 5. Bounds test on Long-run Coefficients in the Unrestricted ECM for testing the existence of level relationships**

<b>Bounds Test for Model 1</b>			
Test Statistic	Value	Probability	Critical bounds value
			5% ((I (0), I (1)), k = 4
F-stat	43.56605	0.000012	(3.05, 3.97)

<b>Bounds Test for Model 2</b>			
Test Statistic	Value	Probability	Critical bounds value
			5% ((I (0), I (1)), k = 4
F-stat	9.70108	0.043899	(3.05, 3.97)

### Results from the Coefficient diagnostic with confidence interval

An alternative approach to displaying the results of a Wald test is to display a confidence interval. The one-dimensional confidence interval is generalized to the case involving two restrictions, where we form a joint confidence region or a confidence ellipse. The confidence ellipse can be interpreted as the region in which the realization of two test statistics is not to reject the null. Fig. 4\_1 and 4\_2 (See, Appendix) show the coefficient test by confidence ellipse for Model 1 and Model 2 at a 95% confidence level with suggestions of failing to reject the null.

### Results from Conditional Unrestricted Equilibrium Correction Model of ARDL

Table 6 displays the results from the Conditional Unrestricted Equilibrium Correction Model of ARDL for model 1. Diverse propensities have been detected from ARDL long run results, where four regressors; income (GDP), aging, physician, and international cooperation patents affecting the growth of healthcare expenditures significantly with different lagged time periods. To be specific, the augmenting level of income (GDP), physician, and international cooperation patents, positively and significantly interrelated with the rising of healthcare expenditures during 1980-2017. As expected, aging negatively at a 10% level of significance interrelated with healthcare expenditures. In the long run, the income elasticity is 0.94 on healthcare expenditures, indicating

healthcare in Israel is a necessity. The technology proxy, international cooperation patents with lag 3 is associated with a 0.04 statistically significant increase on healthcare expenditures.

**Table 6: Results from model 1: Conditional Unrestricted Equilibrium Correction Model of ARDL (5, 0, 4, 3, 4) on HCE**

Variable	Coefficient	t-Statistic	Prob.*
HCE(-1)	0.191082	2.421045	0.0339
HCE(-2)	-0.097056	-1.320541	0.2135
HCE(-3)	0.027826	0.356739	0.728
HCE(-4)	0.032244	0.43121	0.6746
HCE(-5)	0.308745	3.776494	0.0031
GDP	0.943203	4.650565	0.0007
AGE	-1.808692	-2.144911	0.0551
AGE(-1)	2.575548	1.801501	0.0991
AGE(-2)	0.077392	0.05147	0.9599
AGE(-3)	0.508415	0.350672	0.7325
AGE(-4)	-2.072307	-2.306072	0.0416
PHYS	0.225811	0.915933	0.3793
PHYS(-1)	-0.168603	-0.531035	0.606
PHYS(-2)	0.636153	1.982375	0.073
PHYS(-3)	-0.354029	-1.501343	0.1614
COPAT	-0.044253	-1.349883	0.2042
COPAT(-1)	-0.002902	-0.087916	0.9315
COPAT(-2)	0.027885	0.951529	0.3618
COPAT(-3)	0.036929	1.389138	0.0193
COPAT(-4)	-0.021948	-0.985376	0.0456
C	-4.389906	-2.359612	0.0378
R-squared	0.998379		
Adjusted R-squared	0.995432		
Akaike info criterion	-5.276204		
Schwarz criterion	-4.314314		
Durbin-Watson stat	2.627897		
F-statistic	338.762		
Prob(F-statistic)	0.00000		

\*Note: p-values and any subsequent tests do not account for model selection.

**Table 7: Results from model 2: Conditional Unrestricted Equilibrium Correction Model of ARDL (5, 0, 4, 4, 1) on HCE**

Variable	Coefficient	t-Statistic	Prob.*
HCE(-1)	0.200759	2.663301	0.0207
HCE(-2)	-0.140087	-1.86926	0.0862
HCE(-3)	0.043756	0.572364	0.5776
HCE(-4)	-0.054454	-0.775122	0.4533
HCE(-5)	0.232054	3.979775	0.0018
GDP	0.879448	5.104778	0.0003
AGE	-0.446245	-0.380821	0.71
AGE(-1)	1.20671	0.792207	0.4436
AGE(-2)	0.019156	0.013322	0.9896
AGE(-3)	0.1705	0.118303	0.9078
AGE(-4)	-1.151246	-1.230884	0.2419
PHYS	-0.012126	-0.051887	0.9595
PHYS(-1)	0.051253	0.165928	0.871
PHYS(-2)	0.663285	2.231941	0.0455
PHYS(-3)	-0.669718	-2.15428	0.0522
PHYS(-4)	0.441797	1.411202	0.1836
PATENTR	0.001283	0.043864	0.9657
PATENTR(-1)	-0.059864	-1.98933	0.07
C	-3.390307	-3.550825	0.004
R-squared	0.998123		
Adjusted R-squared	0.995308		
Akaike info criterion	-5.262362		
Schwarz criterion	-4.383466		
Durbin-Watson stat	2.31899		
F-statistic	354.513		
Prob(F-statistic)	0.00000		

\*Note: p-values and any subsequent tests do not account for model selection.

Table 7 displays the results from the Conditional Unrestricted Equilibrium Correction Model of ARDL for model 2. Less diverse propensities have been detected from ARDL long run results for model 2 compared with those from model 1, where four regressors; income (GDP), aging, physician, and patent applications from residents, also affecting the growth of healthcare expenditures significantly with different lagged time periods. The augmenting level of income (GDP) and physician, positively and significantly interrelated with the rising of healthcare



expenditures during 1980-2017. As expected, aging has negative effects on healthcare expenditures but not significant. Surprisingly, the patent applications from residents negatively affected healthcare expenditures significantly one year ahead. In the long run, the income elasticity is 0.88 on healthcare expenditures from model 1 estimation, again, indicating healthcare in Israel is a necessity. The technology proxy, patent applications from residents with lag 1 is associated with a 0.06 statistically significant decrease on healthcare expenditures.

**Table 8\_1: ARDL Short-run ECM results for Model 1**

Variable	Coefficient	Std. Error	t-Statistic	Prob.
C	0.023665	0.015043	1.573116	0.1265
D(HCE(-1))	0.378751	0.165422	2.289611	0.0295
D(GDP(-1))	0.007837	0.465922	0.016821	0.9867
D(AGE(-1))	-1.171946	1.246338	-0.940312	0.3548
D(PHYS(-1))	-0.505806	0.481848	-1.04972	0.3025
D(COPAT(-1))	0.029422	0.03907	0.753052	0.4575
ECM (-1)	-1.144946	0.220196	-5.199671	0.000
R-squared	0.577174			
Adjusted R-squared	0.489693			

Note: The ECM (-1) is the one period lagged error-correction term.

### ARDL Short-run ECM results

ARDL Short-run ECM results were reported in Table 8\_1 (Model 1) and Table 8\_2 (Model 2), where the short-run dynamics of income (GDP), aging, physician, and international cooperation patents and the residents patent applications are all insignificantly related to the growth of healthcare expenditures. The inferences explain that healthcare spending in the short run may not be destructive by those factors, rather by the lag of itself, HCE (-1), statistically significant for both models.

Error correction model (ECM) captivated the (ECT) term, where ECM (-1) parameter value (-1.14 for model 1 and -1.07 for model 2) is highly significant at 1% level. The significantly negative ECM values indicate a long-term nexus learned between dependent and independent variables. In addition, the ECT constant (-1.00), defined as how much time it will acquire to readjust the speed of adjustment dynamically from imbalance to equilibrium position. Therefore, the ECM (-1) terms from both models suggest, above 100% level of the disequilibrium will be adjusted towards its long-run equilibrium in a one-year period.

**Table 8\_2: ARDL Short-run ECM results for Model 2**

Variable	Coefficient	Std. Error	t-Statistic	Prob.
C	0.029258	0.01518	1.927365	0.0641
D(HCE(-1))	0.330358	0.17428	1.895559	0.0684
D(GDP(-1))	0.202481	0.494826	0.409197	0.6855
D(AGE(-1))	-1.530029	1.458045	-1.04937	0.303
D(PHYS(-1))	-0.786618	0.58187	-1.35188	0.1872
D(PATENTR(-1))	-0.007842	0.07738	-0.101339	0.920
ECM (-1)	-1.069864	0.221782	-4.823937	0.000
R-squared	0.519657			
Adjusted squared	R- 0.416726			

Note: The ECM (-1) is the one period lagged error-correction term.

**Table 9\_1: Model diagnostic tests results for Model 1**

Tests	$\chi^2$	Prob.
Breusch-Godfrey Serial Correlation LM test	4.266	0.039
Breusch-Pagan-Godfrey Heteroskedasticity test	13.170	0.870
ARCH test	0.685	0.408
Ramsey RESET (F-stat)	0.018	0.895
Jarque-Bera test	0.222	0.895

**Table 9\_2: Model diagnostic tests results for Model 2**

Tests	$\chi^2$	Prob.
Breusch-Godfrey Serial Correlation LM test	1.156	0.282
Breusch-Pagan-Godfrey Heteroskedasticity test	17.677	0.477
ARCH test	0.030	0.863
Ramsey RESET (F-stat)	0.000	0.999
Jarque-Bera test	1.081	0.582

Figure 5\_1: Impulse response function (IRF) for Model 1

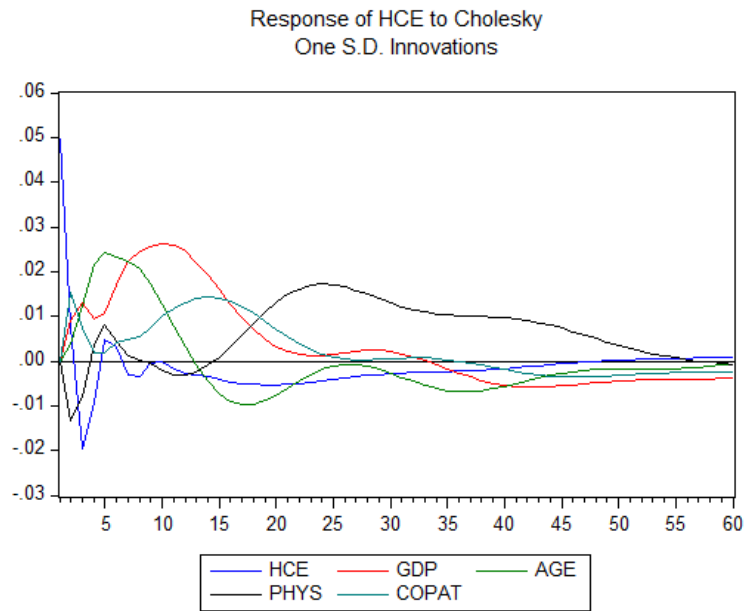

Figure 5\_2: Impulse response function (IRF) for Model 2

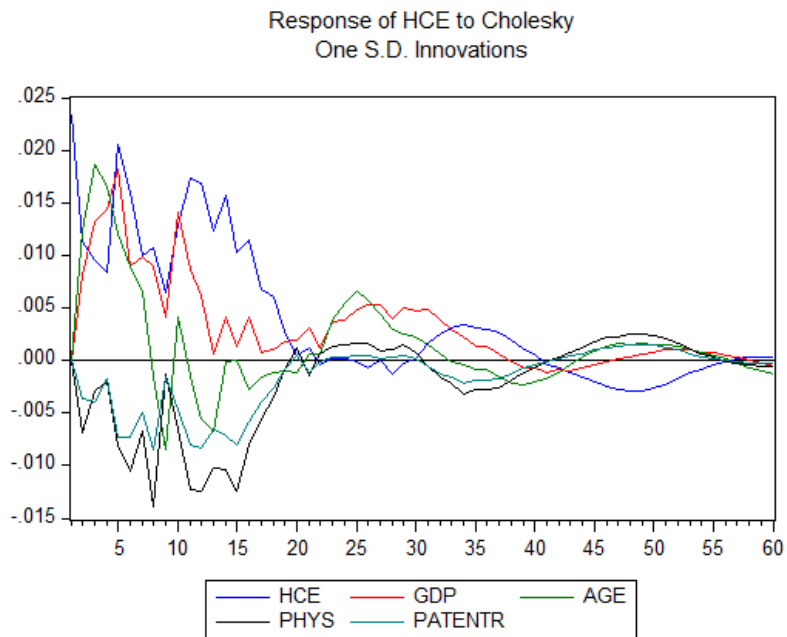
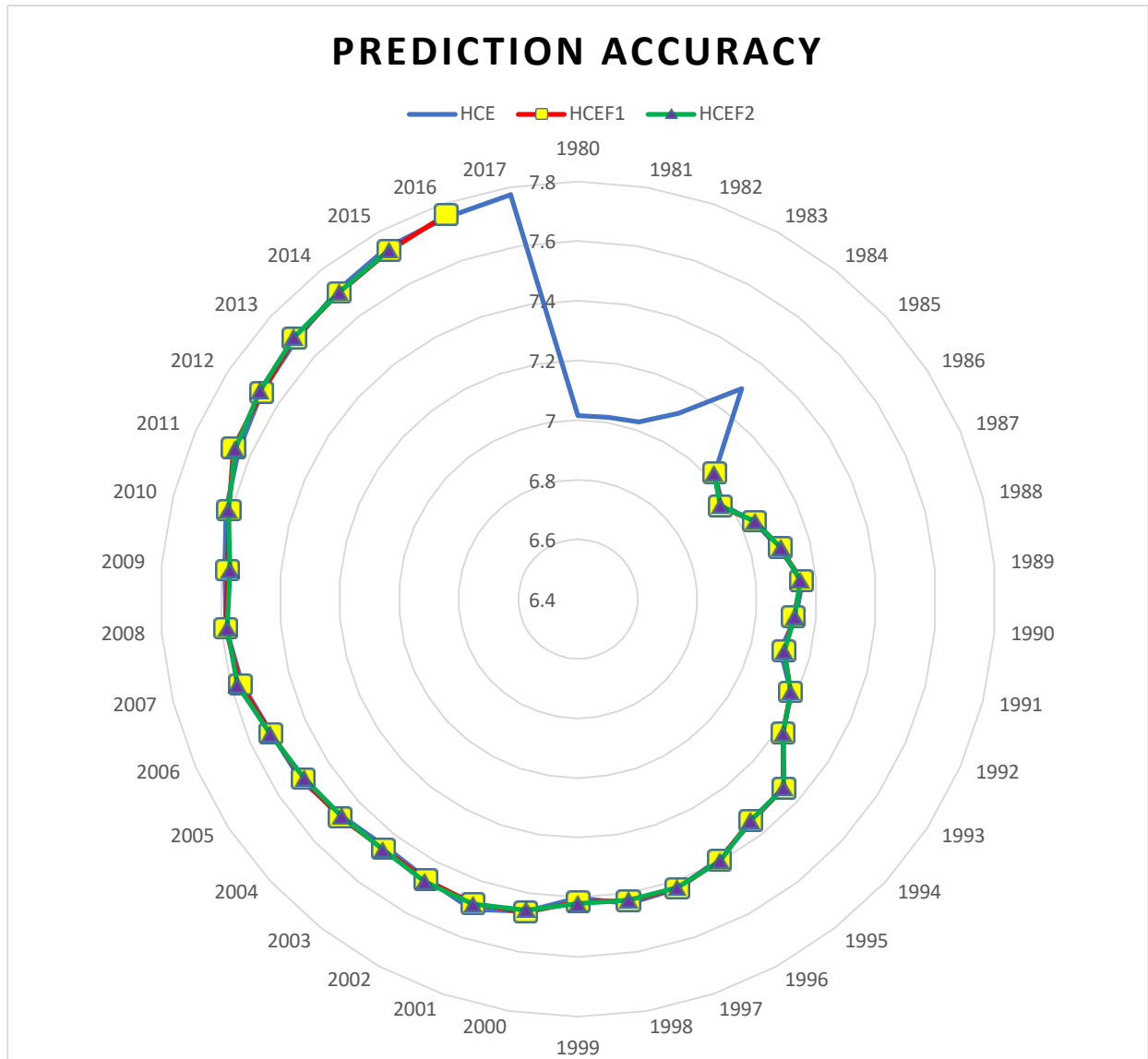

Figure 7: Goodness of fit for the two models at different time points



### Model diagnostic tests results

Model diagnostic tests result from different analytical tests were reported in Table 9\_1 (Model 1) and 9\_2 (Model 2). The tests measure the consistency of the ARDL model and the reliability of the results. The Breusch-Godfrey Serial Correlation LM test checking autocorrelation identification, 4.266 and 1.156, with insignificant probabilities (Model 1:  $p=0.039$ , insignificant at 0.01 level of significance), indicating that there no of serial correlation in model's residuals, besides it the Heteroskedasticity test under Breusch-Pagan-Godfrey and ARCH tests materialized, where values 2-statics (13.17 and 17.677) and (0.685 and 0.030) for model 1 and 2, respectively,

are insignificant which means there is no heteroskedasticity issue in dataset for estimations. Meanwhile, Jerqa Bera tests confirm the normality with the insignificant values, and Ramsey's RESET tests (F-statistics) with insignificant p-value suggest that both models boast the correct functional form without the existence of some significant nonlinear relationships.

The impulse response outcomes specify in Figure 5\_1 (Model 1) and Figure 5\_2 (Model 2). As for model 1, the response function for GDP, was positive in about 40 years span of time; aging was also positive in about 12 years span, then became negative for the rest of time; physician was negative in about 5 years span, then positive for the rest; international cooperation patents, COPAT, was positive in about 32 years span then declined. For model 2, the response function for GDP, was positive about all the time; aging was positive for the first 7 years, then was fluctuating all the time; physician and residents patent applications variables were negative in about 20 years span, then was fluctuating for the rest of time.

### **Comparison of Stability and Fitting Results for the two Models**

The CUSUM test and squared-CUSUM test are used for evaluating the stability of coefficients depicts in Figures 6, the graphical exhibition upholds that the outcome of the ARDL model. The plots of CUSUM and squared-CUSUM are in Figure 6\_1\_1 and 6\_2\_1 CUSUM test for Model 1 and Figure 6\_1\_2 and Figure 6\_2\_2 CUSUM square test for Model 2, respectively (See, Appendix). Both procedure CUSUM figures for both Models ensure that bluelines in both figures are inside the red sprinkled lines, 5% critical bounds, while both squared-CUSUMs are almost all inside the 5% critical bounds. This indicates that estimated parameters are stable over the period of 1980-2017. Furthermore, this exhibition insights that coefficients are suitable for the dependent variable to predict the future.

Finally, we compare the accuracy of the two models by examining their prediction performance. The accuracy of the two models is shown in the Figure 7 radar chart, with the prediction errors of each model are calculated by the formula. As can be seen from the chart, these two models are very accurate, with the predicted  $hcef1$  and  $hcef2$  touching or overlapping the original  $hce$  series for almost all time periods.

## **VI. Conclusion**

This study investigates the growth effects of technology, aging, and physician on healthcare expenditures using the ARDL model with the most recent Israel annual time series data for the period, 1980-2017. Various, diogenitic tests affirm the reliability of model and estimations portrayed that international cooperation patents, GDP, and physician have a positive and significant impact on healthcare expenditures in the long run, while the growth of aging ratio and patent applications by residents negatively but significantly influence the rising of healthcare spending. In the short run, all the independent variables with one-year lag ahead do not have significant effects on the growth of healthcare expenditures, but the one-year lag of the healthcare expenditure itself does.

Our finding indicates that the income elasticity of healthcare expenditures in Israel is less than 1, which means that healthcare in Israel is a necessity good, affordable for Israeli citizens. This

implies the overall functioning of the health care system (including the regulation of health care insurers and providers) and efficient implementation of the health policies and laws. With universal health coverage, individuals in Israel are healthy and happy. Israel was ranked as the 11th happiest nation in the world on the 2018 World Happiness Report, based on responses from thousands of individuals around the globe asked to rate how happy they are with their lives.

In the long run, international cooperation patents have a positive and significant impact on healthcare expenditures while the applications of patents made by residents not. This finding suggests that high-tech cooperation with the rest of the world has significant and while not immediate improvements in Israel's health care. Cooperating with the European and US and being a global leader in the digital health sector, Israel did gain a global competitive on technology innovation through the partnership cooperation.

This study is confined to examining the period 1980-2017, while perhaps a different time period of study would yield different results. For the purpose of this study, specific, international cooperation patents and patent applications by residents were selected as the technology proxies to focus on. The selection of other technology proxies could be interesting to see if that effect on healthcare expenditures behaves differently. Other technology factors may affect healthcare spending in numerous ways and could be interesting to study in the future.



**APPENDIX**

Figure 3\_1: Lags selection criteria under VAR in Polynomial graph for Model 1

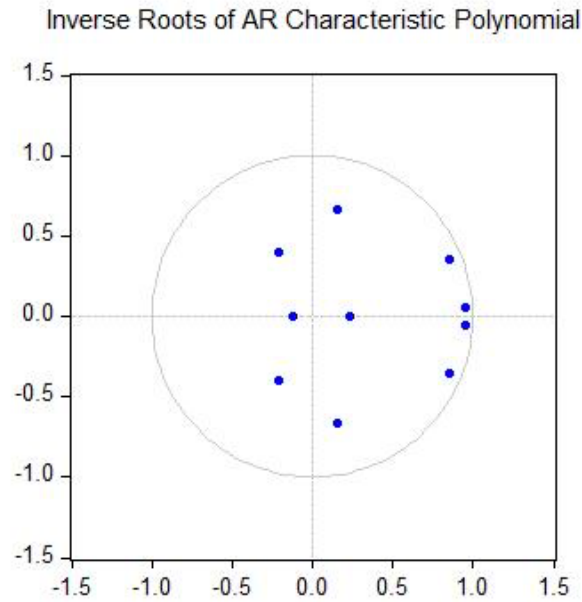

Figure 3\_2: Lags selection criteria under VAR in Polynomial graph for Model 2

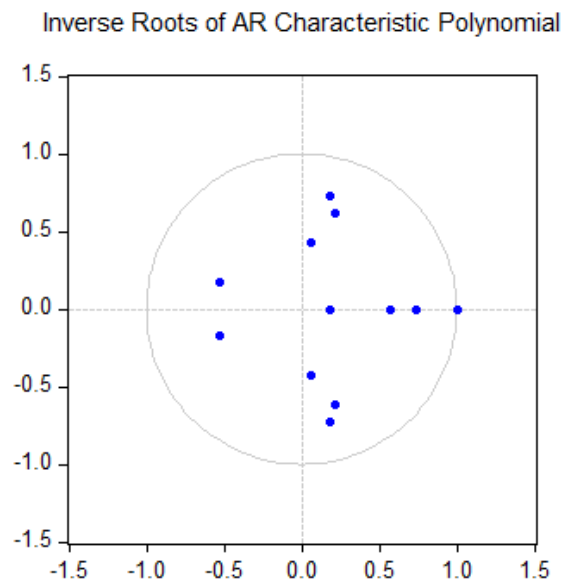



Figure 4\_1: Coefficient test by confidence ellipse for Model 1

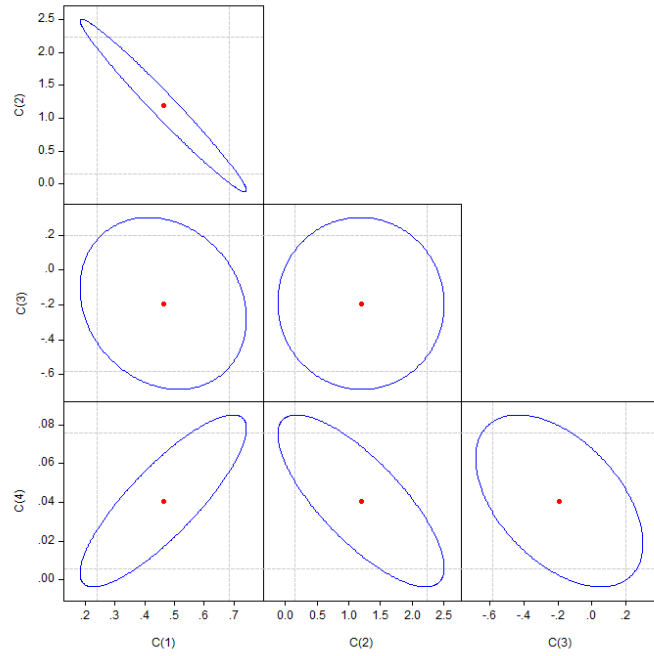

Figure 4\_2: Coefficient test by confidence ellipse for Model 2

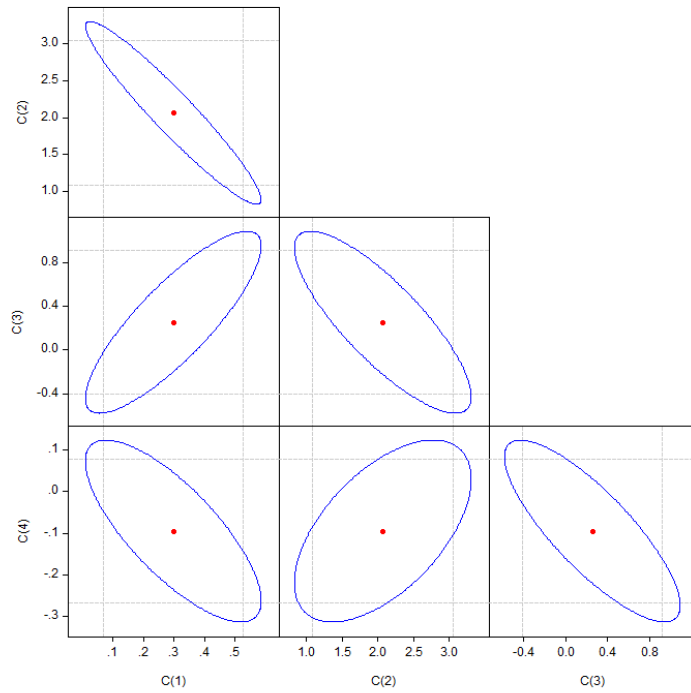

Figure 6\_1\_1: CUSUM test for Model 1

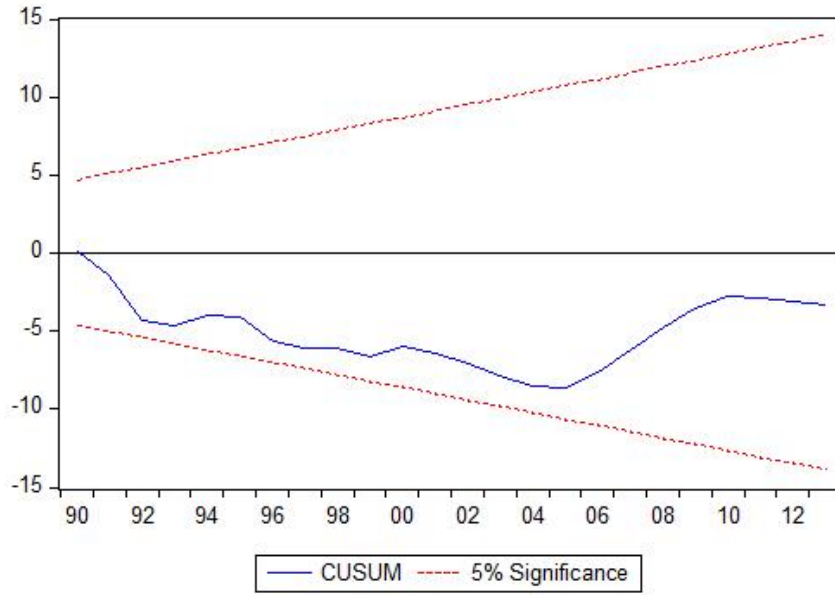

Figure 6\_1\_2: CUSUM square test for Model 1

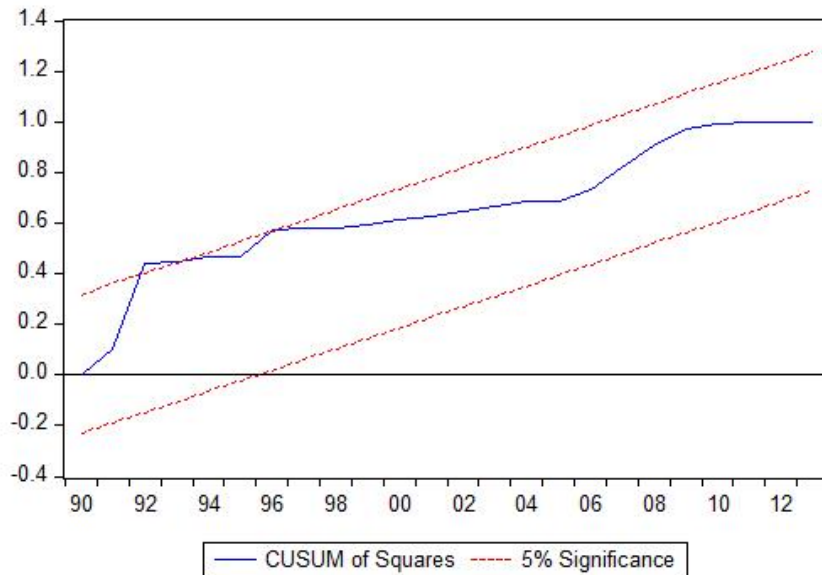

Figure 6\_2\_1: CUSUM test for Model 2

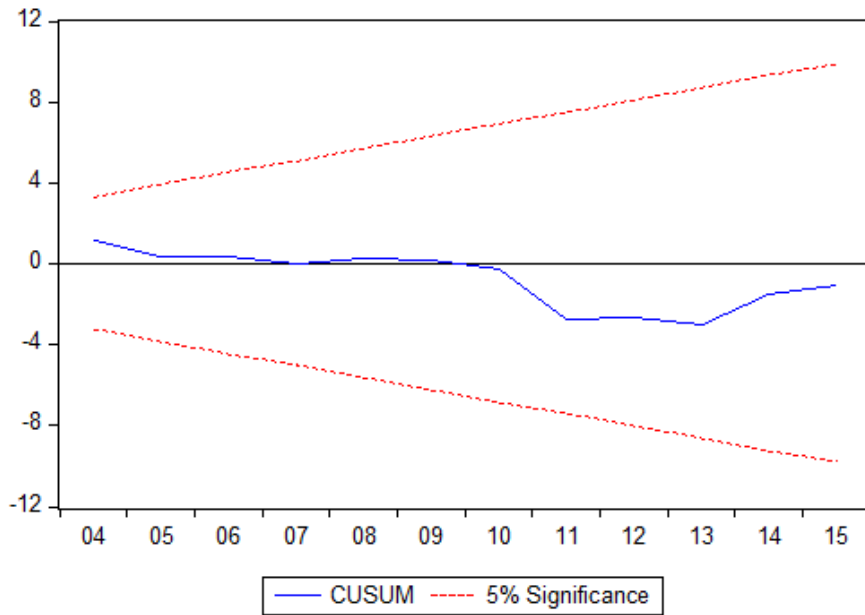
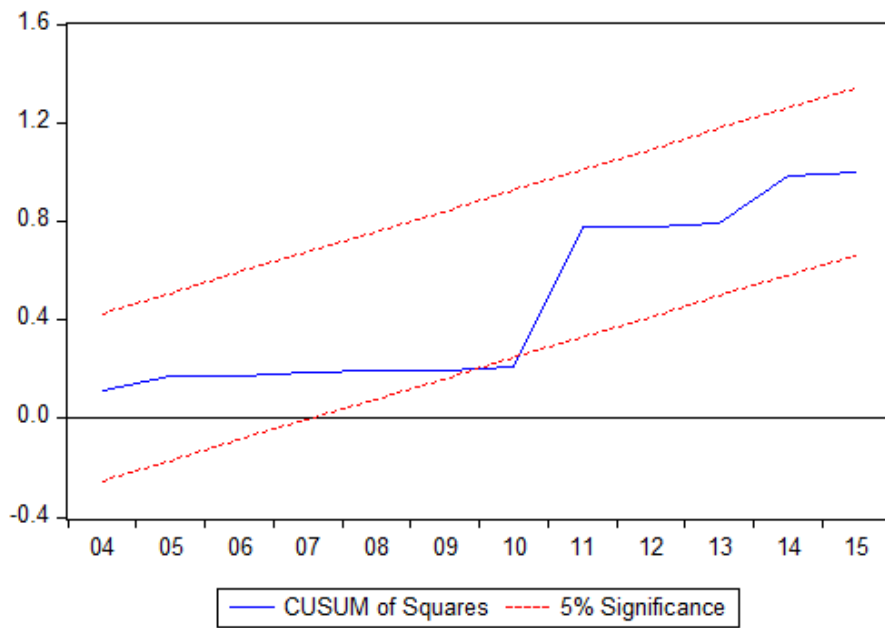

Figure 6\_2\_2: CUSUM square test for Model 2



## REFERENCES

- [1] Abdullah, S.M., Siddiqua, S., and Haque, R. (2017). Is health care a necessity or luxury product for Asian countries? An answer using panel approach. *Health Economics Review* 7(4), 1-12.
- [2] Chandra, A., and Skinner, J. (2012). Technology growth and expenditure growth in health care. *Journal of Economic Literature*, 50(3), 645-680.
- [3] Dickey, D. A., and Fuller, W. A. (1979). Distribution of the Estimators for Autoregressive Time Series with a Unit Root. *Fuller Journal of the American Statistical Association*, Vol. 74, No. 366: pp. 427-431.
- [4] Fishman, R. H. B. (2016). Israel Health & Medicine: Israeli Innovations in Medical Technology, *Jewish Virtual Library A Project of Aice*.
- [5] Getzen, T.E. and Okunade, A.A. (2016). Symposium introduction: Papers on ‘Modeling National Health Expenditures’. *Health Economics* DOI:10.1002/hec.3405.
- [6] Grabowski H. (2002). Patents, innovation and access to new pharmaceuticals. *Journal of International Economic Law* 5(4), 849-860.
- [7] Granger C. J. (1969). Investigating Causal Relationships by Econometrics Models and Cross Spectral Methods, *Econometrica*, Vol. 37: pp. 425-435.
- [8] Kesikoglu, F. and Ozturk, Z. (2013). Relationship between human capital and economic growth: Panel causality analysis for selected OECD Countries. *Journal of Economic and Social Studies* 3(1), 153-162.
- [9] Lo, C. (2019). Israel: a medtech innovation hub for the world. *Verdict Medical Devices* (Available at SSRN <https://www.medicaldevice-network.com/features/israel-medtech-innovation/>)
- [10] Lütkepohl, H. (2006), Forecasting with VARMA Models in Helmut Lütkepohl (eds.), *Handbook of Economic Forecasting*. Vol 1.
- [11] Mehmood, B., Raza, S.H., and Mureed, S. (2014). Health expenditure, literacy and economic growth: PMG evidence from Asian Countries. *Euro-Asian Journal of Economics and Finance* 2(4), 408-417.
- [12] Murthy, V.N.R. and Okunade, A.A. (2016). Determinants of U.S. health expenditure: Evidence from Autoregressive Distributed Lag (ARDL) approach to cointegration. *Economic Modelling* 59, 67-73.
- [13] Murthy, V.N.R. and Okunade, A.A. (2000). Managed care, deficit financing and aggregate health expenditure in the United States: a cointegration analysis. *Health Care Management Science* 3,279-285.
- [14] Newhouse, J.P. (1977). Medical care expenditure: A cross-national survey. *Journal of Human Resources* 12, 115-125.
- [15] OECD Statistics Data Base. (2017) available at <https://stats.oecd.org>
- [16] Okunade, A.A. and Murthy, V.N.R. (2002). Technology as a ‘major driver’ of health care costs: a cointegration analysis of the Newhouse conjecture. *Journal of Health Economics* 21, 147-159.
- [17] Okunade AA, You X, Koleyni K (2018) Cross-country Medical Expenditure Modeling Using OECD Panel Data and ARDL Approach: Investigating GDP, Technology and Ageing Effects. *Health Econometrics in Contributions to Economic Analysis*, Emerald Publishing. 327-358.
- [19] Peden, A.E. and Freeland, M.S. (1998). Insurance effects on US medical spending (1960-1993). *Health Economics* 7, 671-687.
- [20] Pesaran, H. (1997), The Role of Econometric Theory in Modeling the Long Run. *Economic Journal*, 107:178-191.

- [21] Pesaran, M.H., Shin, Y., Smith, R.J. (2001) Bounds testing approaches to the analysis of level relationships. *J. Appl. Econ.* 16, 289–326.
- [22] Rabinovich, M., Wood, F., and Shemer, J. (2007). Impact of new medical technologies on health expenditures in Israel 2000–07. *International Journal of Technology Assessment in Health Care* 23:4, 443–448.
- [23] Rosen, B., Waitzberg, R., and Merkur, S. (2015). Israel: Health System Review. *Health Syst Transit.* 17(6):1-212.
- [24] Sorenson, C., Drummond, M., and Khan, B. B. (2013). Medical technology as a key driver of rising health expenditure: disentangling the relationship. *ClinicoEconomics and Outcomes Research* 5, 223.
- [25] Tang, C. F. and Ch'ng, K. S. (2011). The Granger causality between health expenditure and income in Southeast Asia economies. *African Journal of Business Management* 5(16), 6814-6824.
- [26] Tatoğlu, F.Y. (2011). The relationships between human capital investment and economic growth: A panel error correction model. *Journal of Economic and Social Research* 13(1), 77-90.
- [27] United Nations, Department of Economic and Social Affairs, Population Division (2015). World Population Ageing 2015 (ST/ESA/SER.A/390).
- [28] Wong, A., Wouterse B., Slobbe, L.C.J, Boshuizen, H.C. and Polder, J.J. (2012). Medical innovation and age-specific trends in healthcare utilization: findings and implications. *Social Science and Medicine* 74, 263-272.
- [29] Woodward, R.S. and Wang, L. (2012). The oh-so straight and narrow path: can the health care expenditure curve be bent? *Health Economics* 21(8), 1023-1029.
- [30] You, X. and Okunade, A.A. (2017). Income and technology as drivers of Australian healthcare expenditures. *Health Economics* 26(7):853-862.

## TESTING FOR AN ASYMMETRIC RELATIONSHIP BETWEEN INFLATION AND ITS VOLATILITY

C. Barry Pfitzner, Department of Economics, Business and Accounting  
Randolph-Macon College, Ashland, VA, bpfitzne@rmc.edu

### ABSTRACT

This paper investigates the behavior of inflation, measured by the Consumer Price Index and the Personal Consumption Expenditure Index with primary focus on the relationship between inflation and its volatility. Over the past 70 years, the inflation rate has shown periods of tranquility as well as periods of volatility. Evidence from the early 2000s suggests that inflation, after a period of tranquility during the 1990s, became more volatile early in the new century (perhaps even as early as 1999)—prior to the run-up in the energy and food sectors. Since the 2008-2009 rise in volatility, inflation has entered a more tranquil phase, but is still more volatile than during the Great Moderation of the 1990s. That high inflation is more volatile has long been an accepted tenet for macroeconomists. However, relatively new research has suggested that the relationship between inflation and its volatility is not monotonic—that is, (very) low inflation rates may also be more volatile. This research supports an asymmetric relationship between inflation volatility and the level of inflation. Based on two measures of inflation, very low inflation rates are accompanied by higher volatility, and inflation rates above some threshold (approximately 3.5%) also produce greater volatility.

### INTRODUCTION

Since Okun (1971) presented evidence that nations with higher inflation rates also experienced higher inflation volatility, economists have generally assumed that as fact. Mankiw's recent *Macroeconomics* asserts (in a PowerPoint), "When inflation is high, it's more variable and unpredictable." However, a recent paper by Cobion, Gorodnichenko, and Wieland (2012) develops a theoretical New Keynesian model that produces a relationship between the level of inflation and volatility that is not *monotonic*. That is, very low inflation rates are more volatile when less than some threshold, and more volatile again above that threshold. Cobion, Gorodnichenko, and Wieland (CGW) put that threshold near 3.5 percent inflation. Why would inflation volatility evince such asymmetric effects? The model presented by CGW incorporates the Zero Lower Bound (ZLB) on interest rates where traditional monetary policy is ineffective. In simple terms, at the ZLB macroeconomic volatility increases, including output, consumption, and inflation (CGW 2012, p. 1387).

More recently, Karras (2017) writing in the *Journal of Economic Asymmetries* tests for an asymmetric relationship between inflation and its volatility. That paper utilizes annual inflation from 1800 – 2016, with 5 year overlapping data. Karras finds in favor of the hypothesis of asymmetry, with break points ranging from 0.8% to 4.3%. This range covers the 3.5% suggested by the CGW model.<sup>1</sup>

---

<sup>1</sup> Cobion, et al. do not suggest 3.5% as a *target* inflation rate. Their model suggests a lower target rate of less than 2%, since episodes at the Zero Lower Bound, though costly, are infrequent.

The New Keynesian Model proposed by Cobion, et al., is calibrated using quarterly data from 1947Q1 to 2011Q1. Karras' results cover a very long historical period and provides convincing results. Here I will test the asymmetry hypothesis with data from 1947 to the present.

### **SOME PRELIMINARY ISSUES**

One of the issues in the testing the relationship between inflation and its volatility is how to measure inflation, including the choice of index and periodicity. Here I choose two indexes: The Consumer Price Index measured on a monthly basis from 1947:1 to 2019:9; and the Personal Consumption Expenditure Index measured on a quarterly basis from 1947Q1 to 2019Q2. The former index is chosen for its familiarity. The latter is consistent with the quarterly model of CGW, and thus may be a better choice as a test of their conclusion. In addition, inflation as measured by Personal Consumption Expenditure Index (less food and energy) is the preferred inflation target of the Federal Reserve System. In this work, food and energy prices are not excluded for the price indexes.

A second issue is how to measure volatility. Here I utilize ARCH modeling. The autoregressive conditional heteroskedasticity (ARCH) model was developed by Robert Engle (1982) to explain volatility "clustering," that is, periods in which the variance of a time series is tranquil and other periods in which the variance of the series is more volatile. The ARCH model and its extension, generalized ARCH (GARCH), have been applied to numerous economic and financial series. These models are important in identifying periods of volatility and they also aid in producing more realistic interval forecasts.

### **METHOD AND APPLICATION TO THE CPI AND THE PCE**

#### **Analysis Using the Consumer Price Index**

Consider Figure 1, month-to-month annualized CPI inflation. The figure suggests that inflation was quite volatile in the late 1940s and early 1950s, again in the 1970s, yet again starting around the turn of the century, and during the *Great Recession*. Periods of tranquility were evident in the late 1950s through most of the 1960s, in the 1990s, and in the current recovery. It is well known that simple inspection of the variance of a series can be misleading when the series is autocorrelated.

To remove the autocorrelation of the series, an autoregressive model can be fit to the inflation rate. The lags are chosen by considering standard penalized likelihood model selection criteria. The form of the autoregressive model can be represented as follows:

$$INFL_t = a_0 + \sum_{i=1}^p b_i INFL_{t-i} + e_t \quad (1)$$

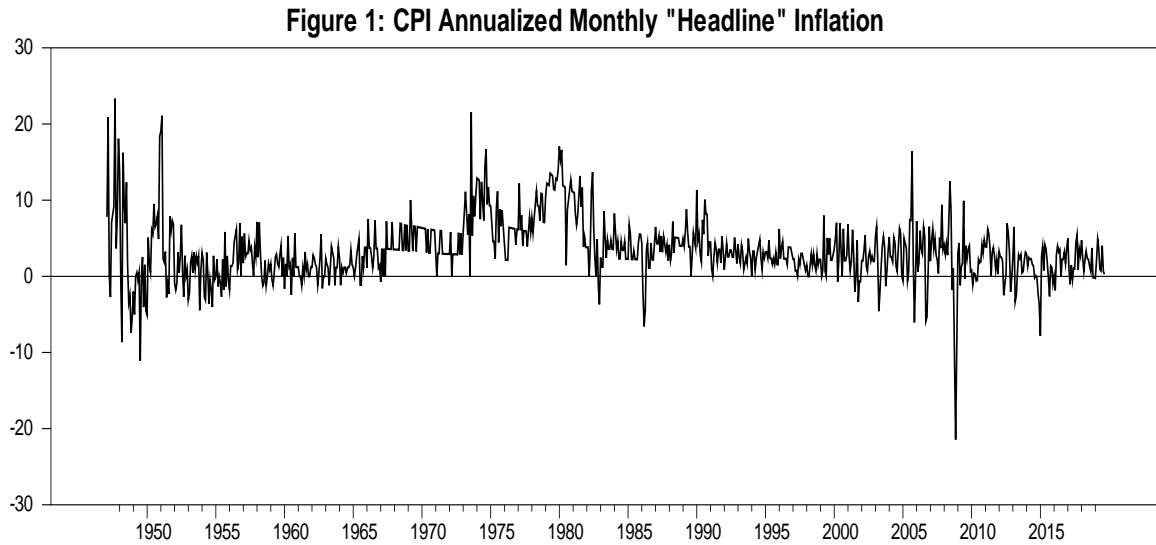

where  $INFL$  is annualized monthly inflation,  $t$  indexes time,  $e_t$  is a white noise disturbance term and the  $b_i$  ( $i = 1, \dots, p$ ) are the lag coefficients, and  $p$  indicates the order of the lags. The two standard penalized likelihood selection criteria employed as guides to choose the order of the lags are the Akaike information criterion ( $AIC$ ) and the Schwarz information criterion ( $SIC$ ) represented as follows:

$$AIC = (2k / T) + \log(\sigma) \quad (2)$$

$$SIC = [k \log(T) / T] + \log(\sigma), \quad (3)$$

where  $k$  is the total number of estimated coefficients in the VAR,  $T$  is the number of usable observations, and  $\sigma$  is the scalar estimate of the variance of the equation's disturbance term. For CPI inflation the  $SIC$  chooses  $p = 12$ , and we present additional evidence based on that model.

Figure 2 depicts the residuals from the autoregressive model for inflation, with the same periods of volatility and tranquility evident.

Testing for volatility is usually accomplished by analysis of the squared residuals from an autoregressive model, such as depicted in Figure 3. The reasoning for testing the squared residuals is simple. The residuals from the autoregressive model (see Figure 2) will be serially uncorrelated as a result of the autoregressive lag fit. Those residuals are, however, not independent. Small (in absolute value) residuals are likely to be followed by additional small residuals, and large residuals are likely followed by other large residuals—that is the meaning of volatility clustering and such clustering is evident in Figure 3.



Figure 2: Residuals From the AR Model Based on the CPI

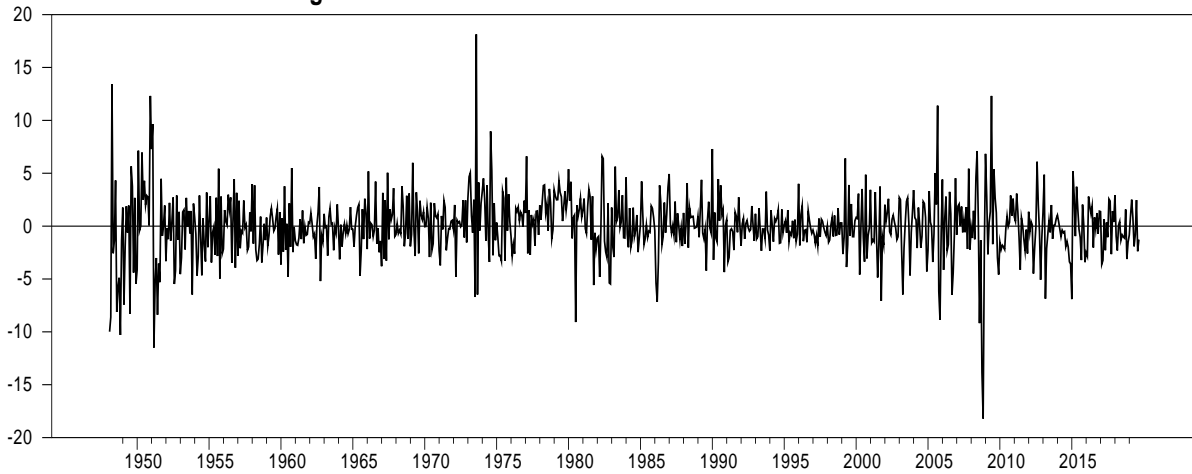
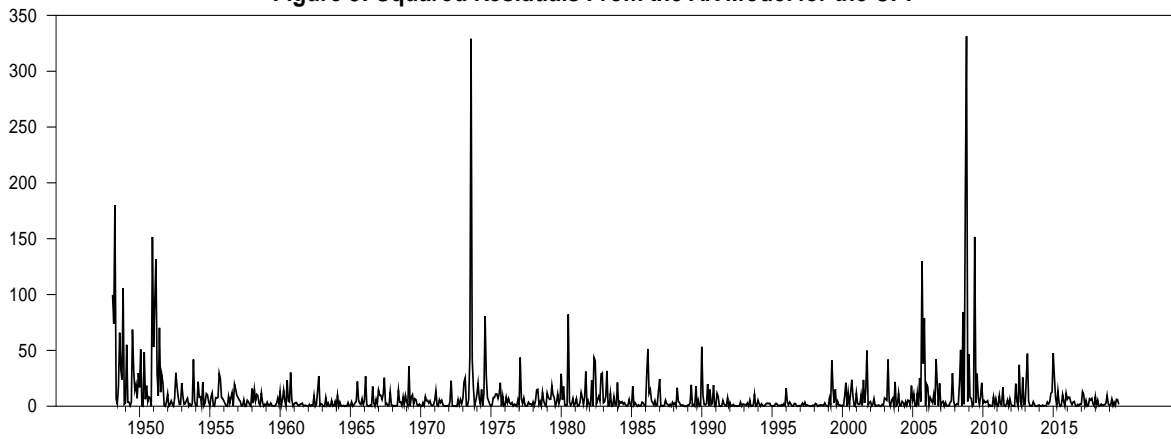

Figure 3: Squared Residuals From the AR Model for the CPI



To test for ARCH errors, a second regression is run:

$$e_t^2 = c_0 + \sum_{i=1}^p d_i e_{t-i}^2 + v_t \quad (4)$$

Where  $e_t^2$  represents the squared residuals from equation 1, and the  $d_i$  ( $i=1, \dots, p$ ) are lag coefficients and  $p$  again indicates the order of the lags. If there are no ARCH effects, then equation 4 will have little explanatory power, i.e.,  $R^2$  will be very low. The existence of ARCH effects can be tested in two ways. First with a sample of  $T$  residuals,  $TR^2$  is distributed as  $\chi^2$  with  $p$  degrees of freedom. Alternatively, an  $F$ -test that all  $d_i$  coefficients are jointly zero will also indicate whether ARCH effects are present. The SIC chooses 3 lags for equation 4.

The estimated equation for (4) is:

$$\hat{\epsilon}_t^2 = 5.10 + 0.23\hat{\epsilon}_{t-1}^2 + 0.06\hat{\epsilon}_{t-2}^2 + 0.10\hat{\epsilon}_{t-3}^2 \quad (4')$$

$$R^2 = 0.0896$$

$$T = 857$$

The null hypothesis of no *ARCH* effects can be written:

$$H_0: d_1 = d_2 = d_3 = 0 \text{ (there are no } ARCH \text{ effects)}$$

$$H_1: \text{some } d_i \neq 0 \text{ (there are } ARCH \text{ effects)}$$

As expected, the null hypothesis is rejected resoundingly for either the  $\chi^2$  test ( $\chi^2 = 76.862$ , p-value = 0.0000), or the *F*-test ( $F_{(df=3,853)} = 28.13$ , p-value = 0.0000). We conclude that the process of inflation is subject to *ARCH* effects. Thus, we have confirming statistical and visual evidence that small squared residuals tend to be followed by small squared residuals, and large squared residuals are more often followed by other large squared residuals.

The *ARCH* errors model is typically estimated simultaneously with the autoregressive model of inflation by maximum likelihood methods. That estimation also yields an estimate of the variance of the series, typically known as the *h* series. Again choosing  $p = 12$  for the autoregressive presentation for inflation, and  $p = 3$ , for the variance of the series, we present the portion of the equation that represents the variance (here, *h*) of the inflation series (here we are less interested in the autoregressive parameters of the estimate of inflation, since many, many, alternative inflation forecasting models are possible):

$$h_t = 2.52 + 0.31\hat{\epsilon}_{t-1}^2 + 0.23\hat{\epsilon}_{t-2}^2 + 0.29\hat{\epsilon}_{t-3}^2, \quad (5)$$

(5.14)          (3.98)          (4.06)

where *h* is the estimated conditional variance in inflation and the numbers in parentheses are t-statistics.

Figure 4 represents the conditional variance of inflation based on the *ARCH* model estimated by maximum likelihood methods. Several things from Figure 4 are striking for the behavior of inflation. First, consistent with prior results, there was a marked period of tranquility, beginning near 1991 and lasting through 1998. Second, the beginning of the early 2000s increase in volatility began earlier than we would have anticipated, even as early as 1999. In 2008 during the *Great Recession*, there was a marked increase in volatility due, in part, to three consecutive months of declines in the CPI. At annualized rates, the declines were 10% in October, 21% in November, and another 10% in December. Since 2010, the recovery phase has seen a period of relative tranquility. Not surprisingly, all of this is consistent with the visual analysis of Figure 3.

To summarize the results of this section, I find in favor of *ARCH* effects for the inflation series. The statistical and visual evidence are very clear. That result is interesting, but not particularly surprising. The extremely tranquil period through most of the 1990s is not surprising. That inflation in the middle to late 2000s is also more volatile is also unsurprising. That the genesis of

that increased volatility seems to have begun as early as 1999 is, perhaps, a surprise. The increase in volatility in 2008, during the *Great Recession*, can be traced, in part, to a tremendous fall (70%) in energy prices during the credit crunch. Energy prices had risen to near record levels by summer of 2008. This period also coincides with the beginning of the period when the FED neared the Zero Lower Bound. Since the volatile phase during the *Great Recession*, headline inflation has returned to a more tranquil period in the recovery period.

**Figure 4: Estimated Variance of CPI Inflation from the ARCH Model, Full Period**

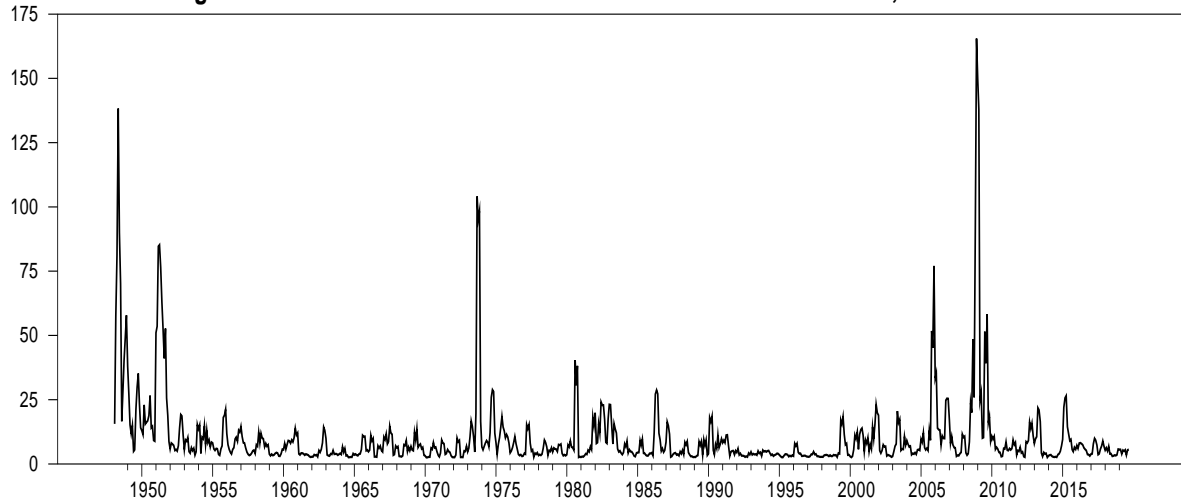

### Testing the Asymmetry Hypothesis With the CPI

A simple regression test of the hypothesis of asymmetry can be devised as follows: first test that volatility is positively related to the level of inflation; then test for asymmetry with a quadratic. In these regressions the “dependent” variable is volatility measured by the *h-series*, an estimate of the variance of inflation. The level of inflation employed is the yearly inflation rate measured as the month of the current year over the corresponding month in the prior year. This measure produces a smoother rate of inflation and eliminates some of the month-to-month behavior that generates the variance of the series.<sup>2</sup> The first regression, testing for the positive relationship between volatility and inflation yields the following estimate:

$$\text{Volatility} = 8.11 + 0.623(\text{inflation}) \quad (6)$$

(3.28)

(t-statistic in parenthesis)

$$\bar{R}^2 = .011$$

$$Se = 15.27$$

<sup>2</sup> Utilizing month-to-month inflation, similar results are found. Those results are available from the author on request.



Note that this estimate is very close to the 3.5% predicted by the model of Cobion, et al. Thus far the data on the CPI confirm the existence of an asymmetric relationship between inflation volatility and the level of inflation, near the threshold predicted by the CGW model.

### Analysis Using the Personal Consumption Expenditure Index

As noted above the CGW New Keynesian model is calibrated with quarterly data and the FED targets inflation as measured by the Personal Consumption Expenditure (PCE) Index. It is therefore appropriate to experiment with that index on a quarterly basis in a search for an asymmetric relationship between volatility of inflation and its level. Here the same methodology is employed as with the CPI. As with the CPI measure the hypothesis of no ARCH errors is rejected for the PCE measure of inflation. Again, a baseline ARCH model (4 lags for inflation and 3 lags for the conditional heteroskedasticity component) is employed.<sup>3</sup> Below only the conditional heteroskedasticity component is presented:

$$h_t = 2.52 + 0.25\hat{\epsilon}_{t-1}^2 + 0.45\hat{\epsilon}_{t-2}^2 + 0.08\hat{\epsilon}_{t-3}^2 \quad (8)$$

(2.49)            (1.69)            (1.27)

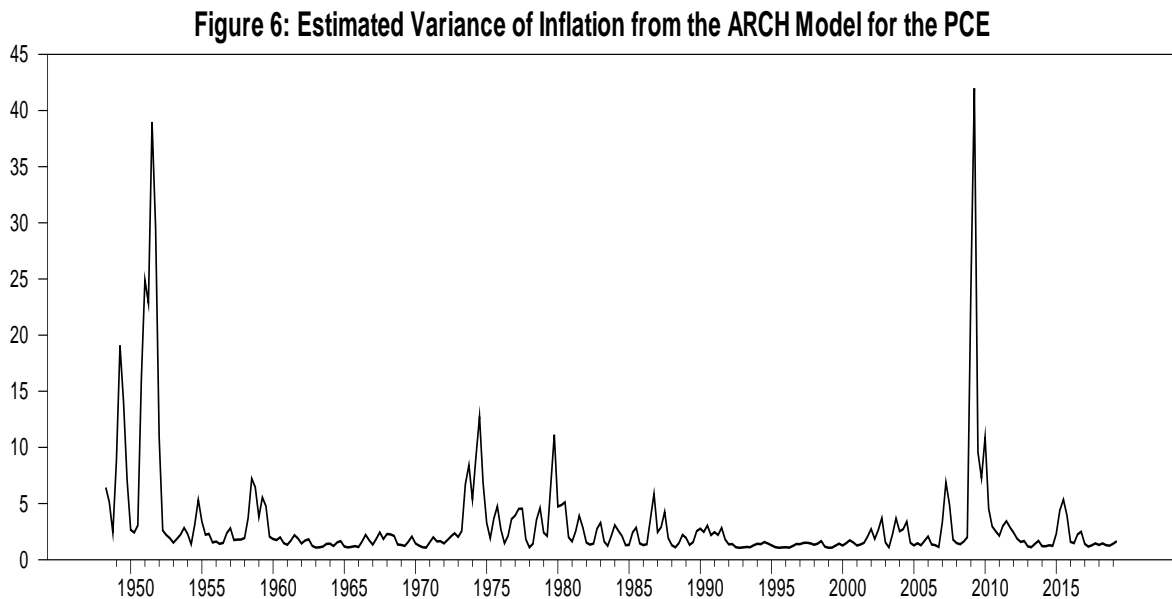

Figure 6 represents the variance in inflation produced by the ARCH model fit to PCE inflation. It is no surprise that it depicts the same episodes of volatility and tranquility as in Figure 4.

### Testing the Asymmetry Hypothesis with the PCE Index

Equation 8 is used to generate the volatility series and as before that series becomes the dependent variable in the tests for a positive relation between the level of inflation and its volatility. The

<sup>3</sup> Again, all estimations are available on request.

results of the first test, that inflation is positively related to the level of inflation produced the following equation:

$$\text{Volatility} = 2.42 + 0.263(\text{inflation}) \quad (9)$$

(2.19)

(t-statistic in parenthesis)

$$\bar{R}^2 = .013$$

$$Se = 4.72$$

The fit of the monotonic relationship in equation 9 is rather weak, though statistically significant at  $\alpha < .05$ .

The quadratic estimation is:

$$\text{Volatility} = 4.39 - 1.147(\text{inflation}) + 0.1570(\text{inflation}^2) \quad (10)$$

(-3.49)                      (4.59)

(t-statistics in parentheses)

$$\bar{R}^2 = .078$$

$$Se = 4.57$$

Equation 10 is a much better fit to the data and as was the case with the CPI provides confirming evidence of the asymmetry hypothesis.

**Figure 7: PCE Volatility versus the Inflation Level**

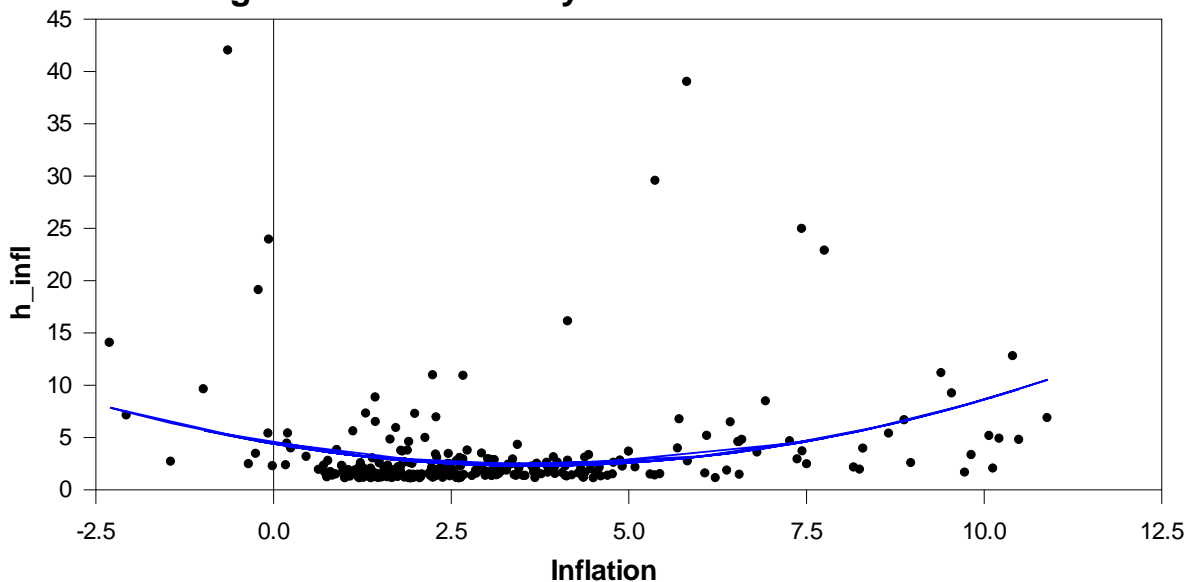

Finding the threshold at which inflation volatility reaches a minimum based on equation 10 yields an inflation rate of 3.65%, again very near to that predicted by the CGW model. Figure 7 shows the fit of the quadratic to the data.

Given the methods employed here we have evidence to support the hypothesis of asymmetry based on monthly inflation from the CPI and quarterly inflation from the PCE indexes—with each having threshold rates near the 3.5% suggested by the CGW model.

### SUMMARY AND CONCLUSIONS

The inflation component of the Federal Reserve System’s dual mandate calls for “stable” prices. Moreover, it has long been a central tenet of monetary policy that the FED should provide a stable background so that decision making on the part of economic agents is not impaired by volatile inflation. The level of inflation and its volatility are important considerations for monetary policy in the US and elsewhere. Generally, it has been assumed that higher inflation produces more volatile inflation, and that the relationship was *monotonic*.

Recent theoretical and empirical work has called into question that lower inflation is necessarily less volatile inflation. That is, below some very low inflation rate, inflation may be more, not less, volatile so that the relationship is asymmetric. Coibion, Gorodnichenko, and Wieland (2012) have produced a New Keynesian model in which inflation is more volatile below (and above) an inflation rate of approximately 3.5%. The 3.5% represents the threshold where minimal volatility is found. Using annual data from 1800-2016, Karras (2017) finds in favor of the asymmetry hypothesis with a threshold somewhere between 0.8% and 4.3% for inflation.

This work utilizes post-war data from two inflation series—that produced from the CPI (monthly) and PCE (quarterly) indexes. In each case, the relationship between inflation volatility and the inflation rate is found to support the hypothesis of asymmetry, with thresholds very near the 3.5% inflation rate suggested by CGW. The general explanation for the increased volatility at very low inflation rates is that traditional monetary policy is ineffective, leading to increased macroeconomic volatility including inflation.

### REFERENCES

- [1] Coibion, O., Gorodnichenko, Y., and Wieland, J., 2012. The optimal inflation rate in New Keynesian models: Should central banks raise their inflation targets in light of the zero lower bound?, *Review of Economic Studies*, 79 1371-1406.
- [2] Enders, Walter. *Applied Econometric Time Series*, John Wiley & Sons, INC. New York, 2014.
- [3] Engel, Robert F. 1982 “autoregressive conditional heteroskedasticity with estimates of the variance of United Kingdom inflation,” *Econometrica* (50, 4), 987-1007.

- [4] Diebold, Francis X., *Elements of forecasting*, 2<sup>nd</sup> edition, South-Western College Publishing, Cincinnati, OH, 2006.
- [5] Doan, Thomas. *RATS user's manual*. Estima, Evanston, Illinois, 2014.
- [6] Karras, Georgios. "Is the relationship between inflation and its volatility asymmetric?" *Journal of Economic Asymmetries* 16 (2017) 79-86.
- [6] Mankiw, G., *Macroeconomics*, (various editions)
- [7] Okun, A. "The mirage of steady inflation," *Brookings Papers on Economic Activity*, 2, 1971, 485-498.



## **WILL OIL GO UP OR DOWN NEXT WEEK: A DECISION TREE INVESTIGATION**

A.G. Malliaris, Quinlan School of Business, Loyola University Chicago, 16 E. Pearson, Chicago, IL 60611, 312-915-6063, [tmallia@luc.edu](mailto:tmallia@luc.edu)

Mary Malliaris, Quinlan School of Business, Loyola University Chicago, 16 E. Pearson, Chicago, IL 60611, 312-915-7064, [mmallia@luc.edu](mailto:mmallia@luc.edu)

### **ABSTRACT**

In this paper, we focus on understanding the directional movement of the spot price of oil from one week to the next. This paper uses seven variables, each in two forms, to model the direction that oil will move. A C5.0 Decision Tree is constructed using these variables as inputs and develops rules that pattern next week's oil direction correctly about 87% of the time. Some input variables used were related to oil and include net imports, days of supply, amount of product supplied, and oil production. The remaining three variables are financial and include the price of copper, the trade-weighted dollar, and a high-yield spread. The data set ranges from January 1997 to early October 2019.

### **INTRODUCTION**

The Global Financial Crisis had a major impact on the price of oil. Just before the dramatic financial developments during September 2007, the price of oil had reached a maximum of \$140 and dropped remarkably down to under \$40 in the spring of 2009. [6] and [15] describe the behavior of oil prices during the crisis. [5] gives early accounts of the Global Financial Crisis. A major shock, such as the 2007-09 Crisis, also produced a significant upsurge in the volatility of oil prices. Often, such volatility persists as hedging and speculation activities persevere. [18] develops this theme of oil speculation and [11] also investigates oil speculation, preferences and volatility shocks using a macro-financial-econometric model with fiscal and monetary responses. Oil speculation during periods of major uncertainty influences the global price of oil, but in the longer-run its impact disappears. [2] reviews the causes of the major oil price shocks since the early 1970s, episode by episode and succeed with their definitive and insightful chronicle to explain why oil prices keep surprising financial markets, policy makers and researchers. The authors list many causes of the past major oil price fluctuations in their chronological exposition, but as the number of these causes increase, predicting the future cause of the next oil price shock becomes very difficult. Other researchers who have studied the pricing of oil find that oil price is a target whose determinants seem to shift frequently.

Illustrative papers that discuss oil forecasting and possible variables and models include [1], [3], [4], [5], [8], [10], [14], [15], and [17]. In this paper, we use several variables, both fundamental and financial, that have been used with some success in varying time periods to build models for oil. While some authors find it necessary to divide their forecasting periods because of structural breaks ([12], [13]) we will look at a continuous period and build one model on that period. This is a time interval of just over 20 years. Here, we focus just on the direction of price. That is, will next week's oil price be Up, Even, or Down in comparison to this week? While human traders often develop a gut instinct for oil price direction, we will instead let an algorithm train on data and learn to make the decision based solely on data. Thus, in this paper we undertake the

challenge of finding rules that explain the direction of oil prices based on the movement of the input variables. The innovation of this exercise consists in using not only fundamental variables describing the movement of oil prices but also financial variables such as the High Yield Spread that were impacted by the Global Financial Crisis. Financial indicators can often be more significant when predicting results related to oil, as demonstrated in [16].

## DATA

Data for this paper were downloaded from the EIA, St. Louis FRED, and Macrotrends. The variables and their sources are shown in Table 1. The target variable is based on the spot price from Cushing for West Texas Intermediate crude oil and is the direction that oil's spot price will have moved a week later. Input variables include how many days' supply of oil are currently available, how much product is being supplied currently (including field production, refinery production, imports, and net receipts), net imports of oil, and current U.S. production in thousands of barrels per day. These weekly values are all available from the EIA. The days of supply in an indicator of how much oil we have already available. Fewer days supply puts more pressure on the price of oil, while a glut of supply can dampen prices. Product Supplied is considered by the EIA to be a proxy for demand. That is, the more barrels demanded currently, the more product that will be supplied to the market. Production encompasses the volume of oil produced from U.S. oil reservoirs. This amount will be transported to refineries and processed. So this gives the model a good indication of what will be available in the near future. Net imports includes the amount we are bringing from other countries minus the amount we have exported. As our own internal production increases, if demand is constant, imports should decrease.

Table 1. Original data for the model.

Name	Series	Source
Net Imports of Oil	WTTNTUS2	<a href="http://www.eia.gov/dnav/pet/pet_sum_sndw_dcus_nus_w.htm">http://www.eia.gov/dnav/pet/pet_sum_sndw_dcus_nus_w.htm</a>
Days Supply of Oil	W_EPC0_VSD_NUS_DAYS	<a href="http://www.eia.gov/dnav/pet/pet_sum_sndw_dcus_nus_w.htm">http://www.eia.gov/dnav/pet/pet_sum_sndw_dcus_nus_w.htm</a>
Product Supplied	WRPUPUS2	<a href="http://www.eia.gov/dnav/pet/pet_sum_sndw_dcus_nus_w.htm">http://www.eia.gov/dnav/pet/pet_sum_sndw_dcus_nus_w.htm</a>
Production	WCRFPUS2	<a href="http://www.eia.gov/dnav/pet/pet_sum_sndw_dcus_nus_w.htm">http://www.eia.gov/dnav/pet/pet_sum_sndw_dcus_nus_w.htm</a>
Cushing Spot Price	WCOILWTICO	<a href="https://fred.stlouisfed.org">https://fred.stlouisfed.org</a>
Copper	Copper Prices	<a href="http://www.macrotrends.net/1476/copper-prices-historical-chart-data">www.macrotrends.net/1476/copper-prices-historical-chart-data</a>
Trade-Weighted Dollar	DTWEXB	<a href="https://fred.stlouisfed.org">https://fred.stlouisfed.org</a>
High Yield Spread	BAMLH0A3HYC	<a href="https://fred.stlouisfed.org">https://fred.stlouisfed.org</a>

In addition, we have three financial variables, copper, the trade-weighted dollar, and a high-yield spread. Copper demand increases when countries experience growth. It is a commodity that can be used as a measure of how well the global economy is doing according to [9]. When global growth increases, oil use typically increases as well. Copper values were downloaded from Macrotrends. Because oil prices are quoted in dollars and the prices must be converted to other currencies when countries import oil, we use the trade-weighted dollar index as another variable that may have an impact on the movement of the price of oil. The last variable is a high-yield

spread. An effect of cheap borrowing costs has been to increase exploration for oil, especially in the fracking arena. As fracking increases, more oil is supplied, and oil prices drop. The variable used here is available from the St. Louis FRED database and is the series designated as BAMLH0A3HYC. Figures 1 – 7 graphically illustrate the relationship of each variable to the spot price of oil from 1997 through 2019. Each graph is shown with two vertical axes, one for each variable.

Figure 1. Net Imports and the Spot Oil Price

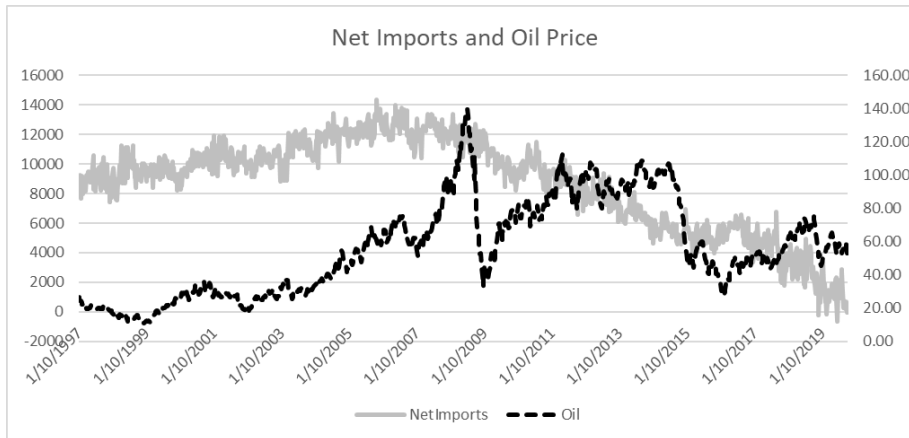

Net Imports were trending slightly up through the end of 2006. When oil prices began an aggressive move up, we see that net imports began a downward trend. As fracking became an important part of production in the years following the financial crash, net imports further decreased.

Figure 2. Days of Supply and the Spot Oil Price

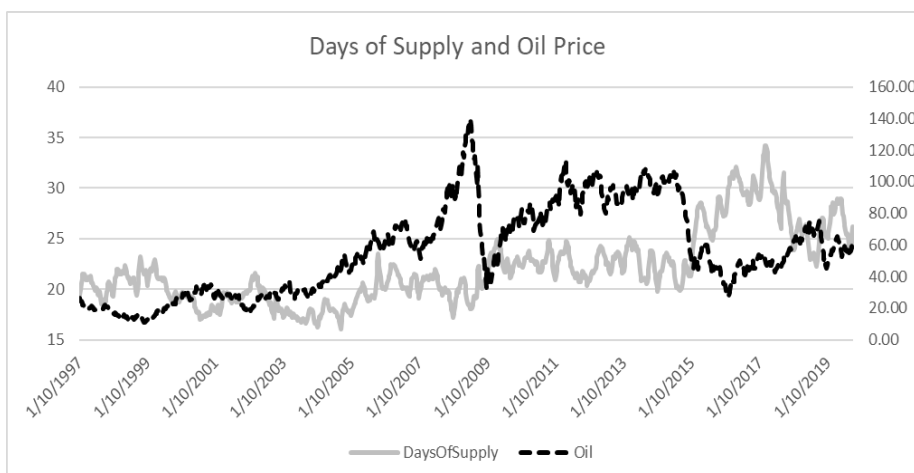

The days of supply varied, but not a lot, from 1997 through 2014. From 2015 onward, the days of supply increased while the price of oil decreased.

Figure 3. Product Supplied and the Spot Oil Price

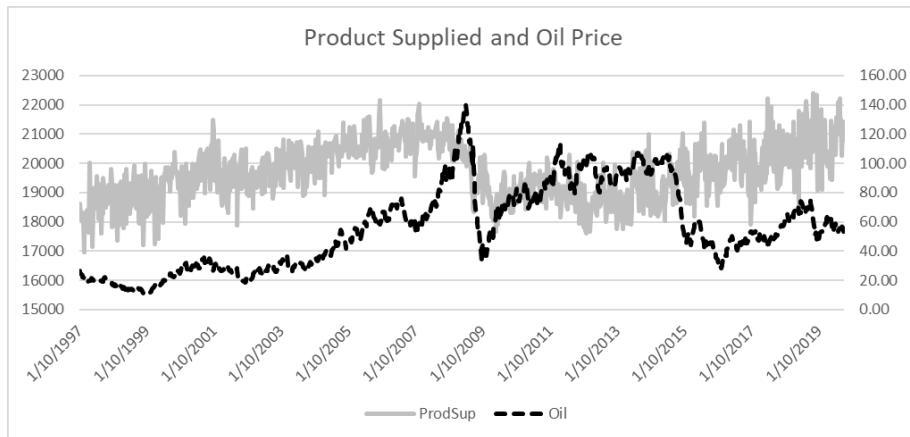

Product supplied refers to the amount of oil that is demanded by, and supplied to, consumers. We see that this demand, from 1997 through 2007 was on an increasing path. When the crash hit, 2008-09, demand dropped then leveled off for several years. In 2014, the upward trend of demand began again.

Figure 4. Production and the Spot Oil Price

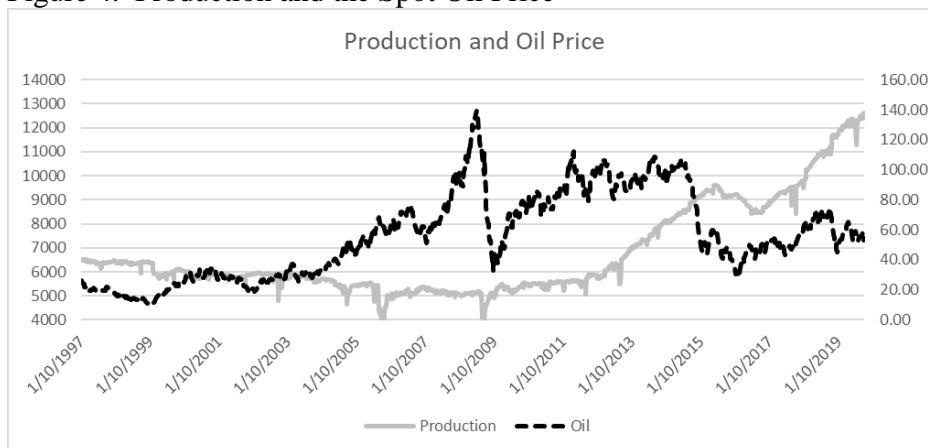

Production, as shown in figure 4 was relatively steady up until 2012. As fracking became more possible due to changes in technology and availability of cheap money, production increased significantly. We see a slight dip in 2015, then a change to another increasing trend. At the end of our time period of study, it has reached the high point.

Figure 5 shows how the prices of copper and oil follow similar though not identical patterns. When countries are growing, both oil and copper are in high demand. When growth slows, as can be seen dramatically in the 2008-09 period, both these prices can drop rapidly.

Figure 5. Copper and the Spot Oil Price

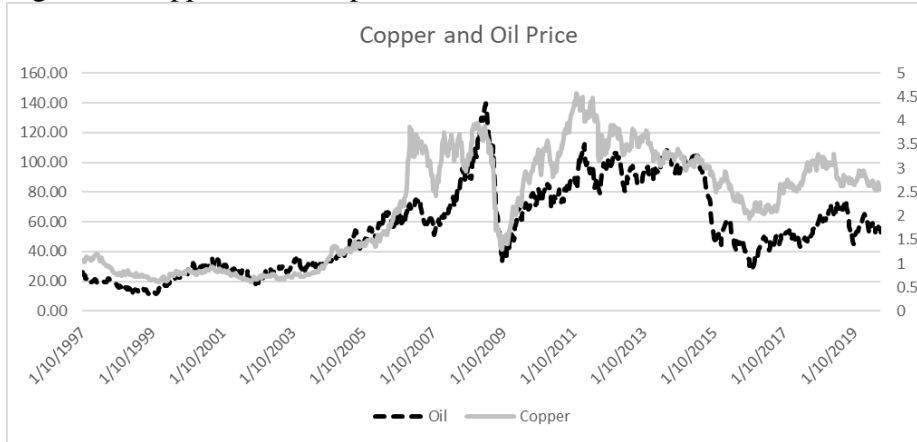

Figure 6. The Trade Weighted Dollar and the Spot Oil Price

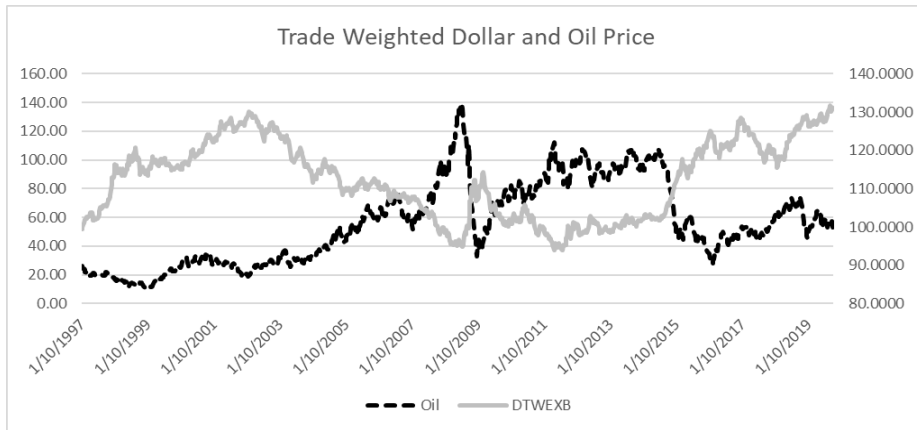
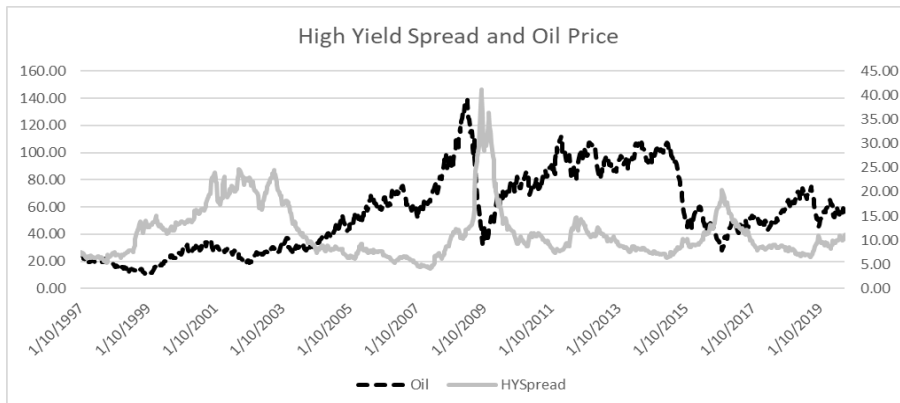

Figure 6 contrasts the movements of the trade weighted dollar and the spot price of oil. This graph indicates opposite movements of these two variables. When the dollar is high, oil is lower. When oil is higher, the dollar is lower.

Figure 7. The High Yield Spread and the Spot Oil Price



Our last chart, in Figure 7, shows the high-yield spread and oil. The High Yield Spread is the spread between all bonds with an investment grade rating of CCC or below and a spot Treasury curve. The bonds are weighted by market capitalization then combined into a single option-adjusted spread index which is compared to the Treasury curve. The spread increased in the 2001-2003 period, during the crash of 2008, and slightly in 2016. In other periods, it has remained more stable.

For each original data variable, columns were calculated for the percent change in the value week to week and the direction the variable moved from the previous week: Up, Even, or Down. For example, the two variables calculated for Net Imports of Oil were the percent change in net imports, and the direction of this change. Using the data in the form of percent change allows the model to identify two pieces of information: the relative amount that this variable has changed from the previous week and whether this change was positive or negative. The variables are also identified as non-numeric inputs when they are transformed to direction. Exposing the model to just the directional movement helps the model focus on just how the variables are moving, but not how much. Since our target is next week's oil price direction, we might expect these other directional variables to help. For Oil, a column with the next week's direction was created to be used as the Target field. As mentioned in [19], the direction of oil price movement is an important decision criterion when making investment decisions in the crude oil market, and is often more important in judging models than a numeric measure such as the root mean-squared error.

After these calculations were done on each of the variables, rows were selected for the data set using only dates where every series had values. Some markets are closed for holidays: 4<sup>th</sup> of July, Thanksgiving, Christmas, etc. and not all series had values for those days. So, Fridays that were not represented in all series were deleted. This left us with a set of 1119 rows beginning on January 10, 1997 and ending on October 4, 2019. Of these rows, 526 had a target value of Down, 4 were Even, and the remaining 589 were Up. Looking at these as percentages, 47% of the weeks showed a Down movement and 52.6% were Up. The variables used, and their names in the model, are listed in Table 2.

Table 2. Variables Used in the Model

<b>Percent Change Variables</b>	<b>Direction Variables</b>	<b>Target</b>
PerChgNetImp	DirNetImp	DirOiltp1
PerChgDaysSup	DirDaysSup	
PerChgProdSupplied	DirProdSupplied	
PerChgProd	DirProd	
PerChgCopper	DirCopper	
PerChgTWDollar	DirTWDollar	
PerChgHYSpread	DirHYSpread	

## MODEL AND RESULTS

The data set was loaded into IBM's SPSS Modeler data mining software. A C5.0 Decision Tree was used to develop a model to explain the target value over this 20-year period. A decision tree successively splits the data into subgroups using the relationships of the input variables to the target variable. C5.0 requires that the target value be non-numeric, but input fields can be either numeric or non-numeric. An advantage of a decision tree as a model is the explanatory nature of the results.

At the first node, the algorithm looks at each of the variables in turn and checks to see whether splitting the data set into subgroups using just that variable would yield subgroups which are more pure in the value of the target field. The single variable that does the best job is used for the first split. After that, each subgroup is inspected and the variable that can split that subgroup further into more pure subgroups is used. Each variable can be used multiple times in any path, often with a split at a different point.

This process continues for each subgroup until one of two things occurs: either the subgroup contains a single value of the target, or there is no variable that the model can split on that can improve the purity of target values. When the tree is finished developing, we are left with a series of paths from the initial root of the tree to each final subgroup. These paths can be converted to a set of rules. A picture of the entire tree can be seen in Figure 8.

Figure 8. C5.0 Decision Tree for determining the direction oil will move next week.

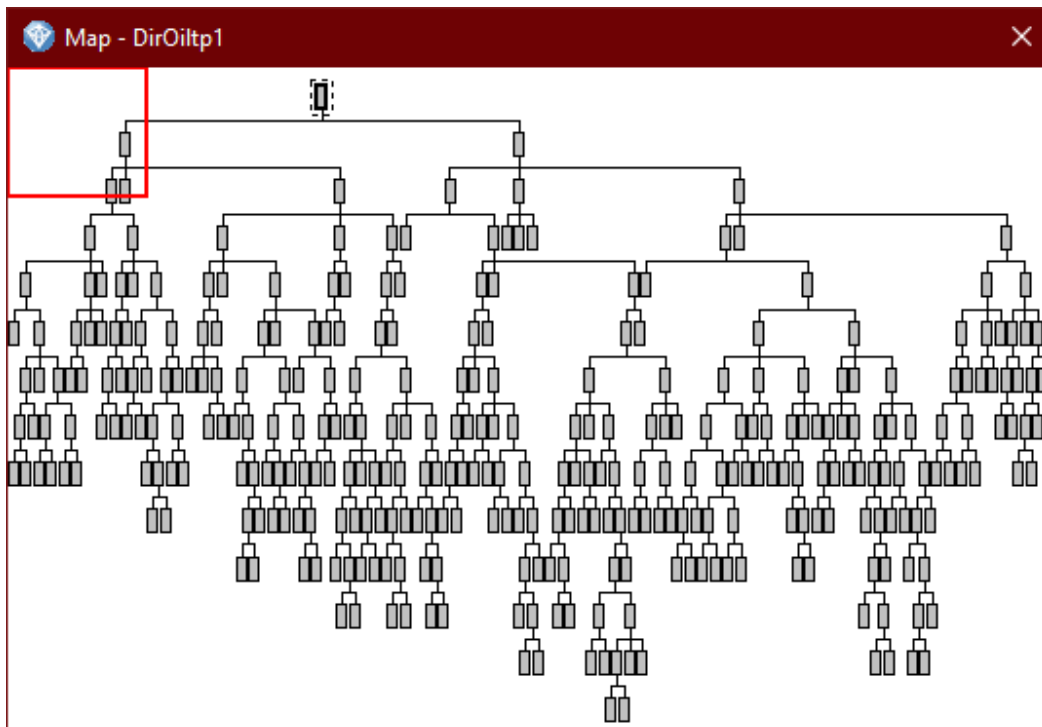

This tree generated 173 rules. Some rules occur often and some occur very few times. The rules most likely to be useful are those that occur more frequently and throughout most of the years. Here are four such examples of paths from this tree:

**Rule 1:**

```
DirTWDollar = Down
  DirCopper = Down
    DirNetImp = Up
      DirProd = Down
        DirProdSupplied = Up
          Then DirOilTp1 => Down (26; 0.769)
```

The conditions for Rule 1 occurred 26 times in the data set. Of these 26 times, the direction of oil in the next week was Down 20 times. Since the model indicates Down always for this set of conditions, it was correct 76.9% of the time. The earliest occurrence of this rule was in 1997 and the last in 2019. The path of the rules goes from the top of the tree down and divides the dataset into finer buckets at each stage, based on the value of a given variable. Here, the rule begins by selecting only cases where the direction of the trade-weighted dollar is Down. That group of cases is narrowed by looking at only the set where the direction of Copper is Down. Focusing on this smaller set with two conditions, the remaining restrictions are applied one at a time: the direction of net imports must be Up, the direction of Production is Down, and the Direction of the Product Supplied (demand for oil) is Down. When all these restrictions have been met, then the model expects the direction of Oil in the next week to be Down.

**Rule 2:**

```
DirTWDollar = Down
  DirCopper = Up
    DirDaysSup = Down
      DirProd = Down
        PerChgTWDollar <= -0.132
          DirHYSpread = Down
            Then DirOilTp1 => Up (41; 0.634)
```

Rule 2 shows a set of conditions that will lead to an Up movement in the spot price of oil in the following week. These conditions occurred 41 times in the data set and correctly indicated an Up direction 63.4% of the time. The first occurrence of this rule was in 1997 and the last in 2019.

**Rule 3:**

```
DirTWDollar = Up
  DirHYSpread = Down
    PerChgProdSupplied > -6.595
      DirProd = Down
        PerChgTWDollar <= 0.723
          DirDaysSup = Down
            DirProdSupplied = Up
              Then DirOilTp1 => Down (21; 0.762)
```



Rule 3 happened 21 times and was correct 76.2% of the time in its prediction of a Down movement in the price of oil. It occurred from 1997 through 2018.

**Rule 4:**

```
DirTWDollar = Down
  DirCopper = Up
    DirDaysSup = Up
      PerChgDaysSup <= 3.004
        DirHYSpread in [ "Even" "Up" ]
          Then DirOilTp1 => Up (39; 0.718)
```

Our last rule’s set of conditions appeared 39 times in the data set. Of these 39 times when the rule expected Up, 71.8% were actually that direction. The examples occurred from 1998 through 2019.

Table 3. Number of Rules for Each Direction

Direction	Number of Rows the Rule Applies to	Number of Rules of this type	Direction	Number of Rows the Rule Applies to	Number of Rules of this type
Down	1	4	Up	1	5
	2	16		2	22
	3	15		3	13
	4	10		4	7
	5	4		5	5
	6	7		6	10
	7	5		7	5
	8	4		8	2
	9	4		9	3
	10	1		10	5
	11	2		11	1
	12	5		12	1
	16	3		14	1
	17	1		15	1
	18	2		16	1
	21	1		18	1
	26	1		21	1
				34	1
				35	1
				39	1
				41	1

Table 3 lists, of the 173 rules, the number of rules for Down and Up and the number of times the rules could be applied. For example, for Down rules, 4 rules were generated whose conditions

held for only 1 row in the dataset. One Down rule was generated whose conditions applied to 26 rows in the dataset. For the Up rules, 5 applied to only one row, while 1 had conditions that occurred 41 times. If we are looking for rules that can be applied at least 1% of the time, we want rules that occur in 11 or more times. In this model, that would give us 15 Down rules and 11 Up rules, for a total of 26 rules, whose conditions occur with enough regularity to be useful in understanding the effect of the variables on the direction of oil.

Once the model is developed and the separate paths are saved, the rules from the model can be used in the future to make forecasts for new data as each week’s worth of inputs becomes available.

In IBM’s software, the methodology not only develops a model, but it also does a sensitivity analysis. This sensitivity analysis gives us the relative impact of variable changes on the final value of the target. This is done by feeding various values of the variable through the model, while holding all other variable values fixed, to see the amount of change in the final target value. These relative sensitivity analysis values all sum up to 1.

This sensitivity allows us to see which variables the model is most susceptible to changes in. Figure 9 shows these values as a bar chart, from highest to lowest while Table 4 gives these as numeric sensitivity values for each variable, again listed from highest to lowest effect. We can see that the top ten inputs, DirCopper through PerChgHYSpread account for about 89% of the variable importance. The remaining variables have importance values below .04 and affect the target value less.

Figure 9. Relative importance of each input variable.

Table 4. Relative Importance Values of Input Variables

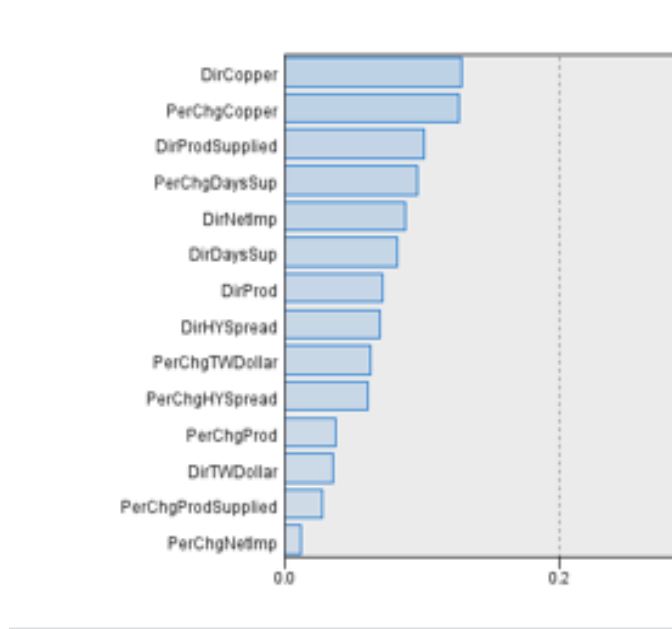

Nodes	Importance
DirCopper	0.129
PerChgCopper	0.1266
DirProdSupplied	0.1015
PerChgDaysSup	0.097
DirNetImp	0.0883
DirDaysSup	0.0818
DirProd	0.0715
DirHYSpread	0.0691
PerChgTWDollar	0.0628
PerChgHYSpread	0.0604
PerChgProd	0.0369
DirTWDollar	0.0358
PerChgProdSupplied	0.0273
PerChgNetImp	0.0122

We can see that the financial variable Copper, in direction and percent change, makes the top two variables and accounts for about 25% of the relative variable importance. The second 25% effect comes from three oil related variables: the direction that demand for oil is moving (product supplied), the change in the days of supply, and the direction that net imports are moving. The third quarter of the relative importance comes from the direction that the days of supply and production are moving, plus the direction of the high yield spread. It takes the remaining six variables to comprise the final quarter of the relative importance, three financial, and three related to percent changes in oil fundamentals. Another way to look at the impact of these variables is by summing the relative importance of the direction and percent change for each base variable.

In Table 5, we see this sum of relative importance values of Percent Change and Direction for each base variable. These are sorted from highest to lowest. For example, the sum of the importance values for PerChgCopper and DirCopper is 0.2556. This lets us see the overall effect of each of the base variables on the model. Of the financial variables, changes in Copper have to greatest importance to the model, High Yield Spread is second, and the Trade Weighted Dollar has the smallest impact. Of the variables related to Oil, the Days of Supply we have already comes in first, followed by the demand for oil (shown as Product Supplied), then Production, and last by the Net Imports. As we saw in Figure 1, since the crash of 2008, net imports have been trending down whether the price of oil increased or decreased.

Table 5.

Variable	Sum of Importance
Copper	0.2556
DaysSup	0.1788
HYSpread	0.1295
ProdSupplied	0.1288
Prod	0.1084
NetImp	0.1005
TWDollar	0.0986

Table 6. Number of correct and incorrect model predictions.

Actual Direction	Predicted Direction	
	Down	Up
Down	452	74
Even	3	1
Up	71	518
Total	526	593

Table 6 shows the number of times the model predicted correctly/incorrectly, with the number of correct values shaded. We see that, in 970 out of 1119 weeks (86.7%), the C5.0 model correctly

identified the direction that oil will move the next week. Notice that the model never identified Even as the value for the following week. Because there are so few of these values, 4 in all, to train on, there are not enough patterns for the model to recognize this as a path.

For the Down weeks, the C5.0 model correctly identified 452 out of 526 weeks, 85.9%. For the Up week, the models correctly identified 518 out of 593, 87.3%. Overall the model was correct 86.7% of the time in identifying the direction that Cushing oil prices will move the next week.

## CONCLUSIONS

We have used a mix of weekly financial and fundamental variables to pattern the direction that oil will move in the following week. The fundamental variables relating to oil were net imports, days of supply, product supplied, production, and the Cushing spot price. The financial variables were copper, the trade-weighted dollar, and a high-yield spread. A single decision tree model was constructed using these eight variables in two forms: as percent change, and as direction. This model used over 20 years of weekly data, from January 1997 to October 2019. The most important variables for the model were a mix of the fundamental and financial variables. The top ten variables accounted for about 88% of the relative importance to the model.

The model was accurate, both on Up and on Down projections, about 86% of the time. On weeks where there was no change (the Even weeks), the model was not able to identify any of these. This is most likely due to the small amount of data that fit this pattern, only 4 weeks, that the model had available while it was training. This decision tree model has demonstrated that this group of variables can model explain relatively well the relationship between what is happening in this set of variables and the direction that oil will move in the next week.

## REFERENCES

- [1] Al-Fattah, SM. (2019) "Artificial Intelligence Approach for Modeling and Forecasting Oil-Price Volatility", *SPE Reservoir Evaluation & Engineering*, vol. 22 (3), 817-826.
- [2] Baumeister, Christiane and Lutz Kilian (2016), "Forty Years of Oil Price Fluctuations: Why the Price of Oil May Still Surprise Us", *The Journal of Economic Perspectives*, Vol. 30, No. 1, pp. 139-160.
- [3] Baumeister, C., Kilian, L. (2015) Forecasting the Real Price of Oil in a Changing World: A Forecast Combination Approach, *Journal of Business & Economic Statistics*, 33(3), pp 338-351.
- [4] Baumeister, C., & Kilian, L. (2014). What central bankers need to know about forecasting oil prices, *International Economic Review*, 55(3), 869-889.
- [5] Bernanke, Ben (2012), "Monetary Policy Since the Onset of the Crisis", Remarks at the Federal Reserve Bank of Kansas City Economic Symposium, Jackson Hole, Wyoming, August 31, 2012.
- [6] Bhar, R. and Malliaris, A., (2011), "Oil Prices and the Impact of the Financial Crisis of 2007-2009." *Energy Economics*, vol. 33, pp. 1049-1054.
- [7] Chen, S. (2014) Forecasting Crude Oil Price Movements with Oil-Sensitive Stocks, *Economic Inquiry*, 52(2), pp 830-844.

- [8] de Albuquerque, V., de Medeiros, R., Besarria, C. and Maia, S. (2018) Forecasting crude oil price: Does exist an optimal econometric model?, *Energy*, vol. 155, pp. 578-591, <https://doi.org/10.1016/j.energy.2018.04.187>.
- [9] Hu, C. and Xiong, W (2013) “Are Commodity Futures Prices Barometers of the Global Economy?”, NBER Working Paper No. 19706.
- [10] Jammazi, R., Aloui, C. (2012) Crude oil price forecasting: Experimental evidence from wavelet decomposition and neural network modeling, *Energy Economics*, 34(3), pp 828-841.
- [11] Morana, Claudio, (2013), “The “Oil-Macroeconomy Relationship Since the Mid-1980s: A Global Perspective”, *The Energy Journal*, vol. 34, pp. 131-156.
- [12] Noguera, J. (2013) Oil Prices: Breaks and Trends, *Energy Economics*, 37, pp. 60-67.
- [13] Salisu, A., & Fasanya, I (2013) Modelling Oil Price Volatility With Structural Breaks, 52, pp. 554-562.
- [14] Shin, H., Hou, T., Park, K., Park, C., and Choi, S. (2013) Prediction of movement direction in crude oil prices based on semi-supervised learning, *Decision Support Systems*, 55(1), pp 348-358.
- [15] Tsai, C.L., (2015), “How Do US Stock Returns Respond Differently to Oil Price Shocks Pre-Crisis, Within the Financial Crisis, and Post-Crisis?” *Energy Economics*, 50:47-62.
- [16] Westgaard, Sjur; Osmundsen, Petter; Stenslet, Lord Olav Daniel; Ringheim, Jo Kogstad. (2017) Modeling superior predictors for crude oil prices. *Journal of Energy Markets*. vol. 10 (2).
- [17] Xiong, T., Bao, Y., Hu, Z (2013) Beyond one-step-ahead forecasting: Evaluation of alternative multi-step-ahead forecasting models for crude oil prices, *Energy Economics*, 40, pp 405-415.
- [18] Yin, L. and Zhou, Y. (2016). What Drives Long-term Oil Market Volatility? Fundamentals versus Speculation. *Economics: The Open-Access, Open-Assessment E-Journal*, 10 (2016-20): 1—26. <http://dx.doi.org/10.5018/economics-ejournal.ja.2016-20>
- [19] Yu L., Wang S.Y., Lai K.K. (2008) Forecasting crude oil price with an EMD-based neural network ensemble learning paradigm, *Energy Economics*, 30 (5), pp. 2623-2635.

**Analytics, Big Data,  
Business Intelligence,  
Data Mining, Statistics  
and Expert Systems -  
Abstracts**

# A Data Analytics Model for Extended Real Estate Comparative Market Analysis

---

Regular Session

---

***Mr . Binu Jacob <sup>1</sup>, Dr . Charles Tappert <sup>1</sup>***

*1. Pace University*

A Data Analytics Model for Extended Real Estate Comparative Market Analysis

Binu Jacob and Charles C. Tappert

Seidenberg School of CSIS, Pace University, Pleasantville, New York

*Abstract:* As part of real estate sales, a comparative market analysis is an analysis that is provided to most of the prospects and customers. Currently, this market analysis typically includes only nearby properties and is rather superficial. In the case of an investor, the list of properties in the analysis should include properties beyond the nearby area. In this study, data analytics tools for clustering, classification, and recommendation models were explored with the aim of producing a larger and more detailed list of properties to resolve these issues.

# ADVANTAGES OF EXPERIENTIAL LEARNING FOR MBA STUDENTS

---

Regular Session

---

***Dr . Mohammad Ahmadi <sup>1</sup>, Dr . PARTHASARATI DILEEPAN <sup>1</sup>, Dr . Marilyn Helms <sup>2</sup>***

*1. Gary W. Rollins College of Business, The University of Tennessee Chattanooga, Chattanooga, TN 37403 , 2. Dean School of Business, Dalton State College 650 College Drive, Dalton, GA 30720*

This paper describes a student-centered experiential learning component of the MBA level quantitative decision analysis course and benefits from this high impact practice as viewed by students and faculty. In this student-centered experiential learning component, teams work on research projects in which they apply theoretical model-building knowledge to actual 'real-world' business problems. Following completion, a survey of students' opinions regarding the experiential learning component of the course showed positive results. Most students were "very satisfied" to "satisfied". Steps for implementation are included following the discussion along with areas for future research.



# An initial empirical investigation of the use of SODA I and II

---

Regular Session

---

***Dr. Patrick Hester*** <sup>1</sup>

*1. UNC Asheville*

Problem structuring methods are espoused by many researchers and practitioners as being useful in the context of framing and understanding wicked problems. The utility of these methods is often demonstrated anecdotally through stakeholder surveys and interviews. However, there is a lack of clear, empirical demonstration of the utility of these methods as contrasted with problem solution efforts not using such methods. As an initial experiment, a group of undergraduate students was exposed to two problem structuring methods, Strategic Option Development and Analysis (SODA) I [5] and SODA II [6]. These methods were utilized on a fictitious problem and confidence in student recommendations was analyzed. Further, SODA I and SODA II were assessed for their relative utility in understanding complex problems. This second set of experiments was repeated using two separate example problems to test robustness of results. A set of hypothesis tests was used to analyze the results of these experiments. Initial results indicate some significant findings supporting the use of problem structuring methods and a need for further research.

# Assessing Data Normality While Using Resources Across Multiple Disciplines

---

Regular Session

---

*Dr . Anna Johnson-Synder <sup>1</sup>, Dr . Brenda Killingsworth <sup>1</sup>*

*1. East Carolina University*

Experimental researchers frequently find violations of the normality assumption in dependent variables after a survey has been designed and implemented. Sources are split on which tests or methods to use when addressing such normality issues. Researchers must traverse these resources to ascertain what source to use as support for data analyses. In this research, we summarize advice found across multiple disciplines on how to address normality assumption violations.

# Blockchain-based Traceability in Supply Chain Network: Modeling and Implications

---

Regular Session

---

***Dr . Binshan Lin*** <sup>1</sup>

*1. LSU Shreveport*

Blockchain can be applied to many challenges of the supply chain networks such as complicated record keeping and tracking of products. As a less corruptible and better-automated alternative to centralized databases, the integration of blockchain technology into a traceability system that allows consumers to trace the ingredients of products could easily accomplish transparency, traceability, and information sharing throughout the product supply chain. Blockchain has also led to a disruption in the supply chain network by removing the trust related issues.

We first address the deficiency of diffusion of innovation theory and enhanced the current state of knowledge by investigating the direct influence of institutional theory on the diffusion of innovation theory and discovering the mediating role of institutional theory on the diffusion of innovation theory. This study serves as a pioneer study in applying the institutional theory to understand the intention to participate in a blockchain-based system.

We then model the relationships between the enablers of blockchain adoption in supply chain network. This study has several implications for the current state of knowledge. Finally, we lay out future research directions.

# Characteristics of Communication Transmission Using Twitter During a Natural Disaster

---

Regular Session

---

*Dr . Chia-Hsuan Yang <sup>1</sup>*

*1. James Madison University*

Government agencies have been using social media (e.g. Twitter and Facebook) to communicate interactively with the public during disasters (e.g. hurricanes, wildfires, floods, and earthquakes). While government agencies are developing communication practices for social media to enable efficient communication with the public, it is also important to know which communication channels the population is using and how they're using them. In this study, we will analyze the twitter usage during Hurricane Irma to explain what parts of the population would be most likely to receive information about a disaster using social media, what topics they were discussing at the time of the disaster, where they received the information, and how they got the information (i.e. (re)tweet of news, (re)tweet of government agencies, or re(tweet) of friends' text). 6,225,061 tweets were collected during the Hurricane Irma disaster, from September 1, 2017 to September 14, 2017, which contained the keyword: "Irma". During the same period, 5,916,281, tweets containing specific hashtags, "#Irma", "#HurricaneIrma", "#IrmaHurricane", "#HurricaneIrma2017", or "#IrmaHurricane2017" were identified. The tweets will be analyzed to understand: 1) the topics of those tweets, 2) the origin of the tweets (if they were retweeted), 3) the characteristics of the tweets and users, and 5) how these factors intertwined with each other. Both machine learning and statistical approaches will be utilized. Machine learning approaches, such as topic modeling and text mining, will identify the topics of those tweets and cluster tweets around those topics. A statistical model will be used to explore the relationship between the factors.

# Developing Better Surveys: Applying Topic Modeling and Sentiment Analysis for Item and Scale Development

---

Regular Session

---

*Prof. Sven Rehm*<sup>1</sup>, *Prof. Mark Hartley*<sup>2</sup>, *Prof. Iris Junglas*<sup>2</sup>

*1. EM Strasbourg Business School, 2. College of Charleston*

In this abstract, we propose a combination of topic modeling and neural sentiment analysis to streamline and introduce additional rigor to the item development process for evaluative constructs. While topic modeling (or Latent Dirichlet Algorithm) is an example of an unsupervised approach to text analysis that uncovers hidden structures (or themes) based on probabilities of co-occurrences, neural sentiment analysis detects the mood that is expressed in-text. The application of topic modeling ensures that survey measurement items capture the universe of interest and represent an existing topic; the application of sentiment analysis assists in safeguarding that the scale chosen for each measurement item is a valid one to take. By utilizing both, researchers will be able to leverage machine learning mechanisms to enhance the content validity of measures, along with the proper anchoring of scales, for an advanced survey design.

## Do Business Analytics Abilities Vary in Different Industries?

---

Regular Session

---

***Dr . Hong Qin <sup>1</sup>, Dr . Haoyu Wen <sup>2</sup>, Dr . Kai Koong <sup>3</sup>, Dr . Lai Liu <sup>1</sup>***

*1. The University of Texas Rio Grande Valley , 2. Xidian University , 3. Tuskegee University*

The Big Data revolution creates challenges and opportunities for business communities and academic research. With the rapid development of high technology, Business Analytics (BA) is obtaining growing attention in a variety of business domains over the past two decades. This study develops SWEET framework and SaaS software for data crawling and analysis. Using associational analysis and demographic segmentation, it identifies existing and innovative BA professional skills and abilities. Moreover, it examines the different BA skills demanded for different industries and their relationships. The findings can benefit companies for recruitment, help higher education for curriculum design and job hunters for market preparation.

# Estimating the Weighted Average Cost of Capital for Operating Assets

---

Regular Session

---

*Prof. Chengho Hsieh<sup>1</sup>, Prof. Timothy Vines<sup>1</sup>*

*1. LSU*

A firm's total assets includes non-operating and operating components. In the conventional value-based management and economic value added models, the value created comes from the firm's operating assets; therefore, the weighted average cost of capital in the models should also be based on the operating assets instead of the total assets. A method to find this cost of capital is presented.

# Examining the topics in the DSJIE 2003-2019 and JSE 2003-2019 with Text Analytics

---

Regular Session

---

***Dr . Kellie Keeling***<sup>1</sup>

*1. University of Denver*

Text Analytics allows researchers to gain insight and understanding about unstructured data in documents. In this paper I am examining the titles, keywords, and abstracts for the Decision Sciences Journal of Innovative Education for the years 2003 (its beginning) to 2019 and the Journal of Statistics Education during the same time period. The goal is to determine the topics that have been reported on over the past 17 years in the statistics and business analytics education literature. In particular I am examining the words and phrases that appear most often. In addition, I am breaking down the articles over time from 2003-2007, 2008-13, and 2014-19 to focus on the changes in terms over time.

Pilot results show that common topics in the titles for DSJIE include “exercise”, “project”, “game”, and “online.” Common topics in the abstracts include “group,” “online,” and “team”. In addition there has been an increase “supply chain”, “study abroad,” and “spreadsheet” mentions in abstracts over time. In the titles, there has been a move away from terms such as “web based” and an increase in the terms “project” and “learning studio.” Common bigrams include “learning outcomes,” “supply chain,” “operations management,” “information systems,” and “student learning.” Common trigrams include “supply chain management” and “undergraduate business students.”

The final part of the study will use LDA topic modeling in order to identify over-arching themes and clusters that appear in the articles. It is hoped that based on this exploration a representative educational research taxonomy may be found to classify these articles.



# Flight Disruption Insights with Big Data Analytics

---

Regular Session

---

**Mr . Krishna Bathula <sup>1</sup>, Ms . Kaleemunnisa Lnu <sup>1</sup>, Dr . Charles Tappert <sup>2</sup>**

*1. Pace University , 2. Pac University*

Flight Disruption Insights with Big Data Analytics

Krishna Bathula, Kaleemunnisa LNU, Charles C. Tappert, Istvan Barabasi, and Ronald I. Frank

Seidenberg School of CSIS Pace University, Pleasantville NY

*Abstract*—Data is exponentially growing and in different forms such as structured, unstructured and semi-structured. This study uses big data analytics concepts and machine learning algorithms to work with structured data of flights, airports, airlines and weather information. The objective is to represent the correlation between different data points among the datasets and use these associations to identify the key features that can disrupt flight schedules and lead the study for impact analysis. The domino effect that is passed on to the stopover and connecting flights in the route to their destinations is also predicted. These insights provide the basis for disaster management and recovery of valuable air time as the delays in flights influence the economy of airport authority, airlines and flyers, causing damage to environments due to increased consumption of utilities like fuel and gas.

# Framework and Patterns for Machine Learning as Microservices

---

Regular Session

---

*Mr . Istvan Barabasi <sup>1</sup>, Dr . Ronald Frank <sup>1</sup>, Dr . Charles Tappert <sup>1</sup>*

*1. Pace University*

## **Framework and Patterns for Machine Learning as Microservices**

Istvan Barabasi, Ronald I. Frank, and Charles C. Tappert

Seidenberg School of CSIS, Pace University, Pleasantville, New York

*Abstract:* This study explores implementing and using machine learning in an easy, scalable, and sustainable way to solve common everyday problems. There are multiple challenges with new technology adoption and constraints around accessing and using data, running computational workload, especially when using multiple cloud vendors and proprietary technologies. The paper proposes adopting the microservices architecture style to implement and practice machine learning, applicable for a broad set of machine learning frameworks and algorithms.

*Keywords:* machine learning, deep learning, data analytics, microservices, containers, cloud native, open source.

---

# Hypothesis Hypothesis testing: How much do researchers and graduate students know about it?

---

Regular Session

---

*Dr . Reza Kheirandish <sup>1</sup>, Dr . Shabnam Mousavi <sup>2</sup>, Dr . Uwe Czienskowski <sup>2</sup>*

*1. Clayton State University , 2. Max Planck Institute for Human Development*

Statistical analysis is one of the main tools for many empirical studies. In statistics, the Hypothesis Testing is one of the essential tools that have been used in many different disciplines, including Economics, Marketing, Management, Psychology, to name a few. But despite its popularity among researchers, Hypothesis Testing is a very controversial and misunderstood topic, maybe now more so than ever, and even thoughtful and intelligent statisticians and researchers have major disagreements about the value of Hypothesis Testing. The classical Hypothesis Testing framework has been criticized since the late 1920s, especially by Bayesians. Since early twentieth century, there has been heated debates between Fisher and Neyman –Pearson and some statisticians simply dislike p-values altogether. In this paper, we want to see whether the general understanding of the “trained professionals” and/or the graduate students about Hypothesis Testing are as bad as depicted in some of the previous studies or not? We provide our case, which involves a ritual of performing statistical Null Hypothesis Testing that requires close scrutiny and we believe it can shed light on the recent concerns with the lack of scientific transparency and replication crisis. We present the results of our study on Hypothesis Testing literacy among one hundred academics, students, and practitioners who were participants in five different business and economics conferences, and compare them to the previous results in the literature. Using a survey of twenty True or False questions (we have also added “Don’t Know” and “Ambiguous/Undecidable” to the possible responses), we have asked participants to test their understanding of the Hypothesis Testing, with absolutely no deception (full transparency about the intent of the study) and voluntary participation in answering the survey which biases the results positively: Only those who are more comfortable with the topic and confident about their knowledge of the subject matter will participate. We also look at the differences between economists and other business professionals. The results of the study are alarming, to say the least and show a deep misunderstanding about this statistical tool both among economist and other business professionals even in our positively biased sample which suggest an even more pronounced problem in an unbiased sample. For future research, we plan to collect more data from different conferences and analyze it. In the next phase of this research, we also plan to point out ways to improve the statistical practices in social sciences and business schools and provide suggestions for a smooth introduction of elements into the curricula and textbooks that rectify the presented shortcomings.

# IMPROVING LOGISTICS PERFORMANCE IN THE DIGITAL ENTERPRISE

---

Regular Session

---

***Dr . Jose Gavidia*** <sup>1</sup>

*1. College of Charleston*

The integration of technologies and real-time data analytics tools is revolutionizing the ERP landscape in an evolution toward the digital enterprise, and this trend will continue for many years to come. This paper analyzes the drivers of the current transformation of ERP systems, current pain points in logistics, production and supply chain management, including long planning and reaction times due to lack of visibility and analytical tools. The paper then addresses how intelligent ERP systems have evolved by integrating data, processes, and technologies. The digital enterprise can address logistics shortcomings through augmented capabilities via Internet of Things, machine learning and analytical tools that allow detecting problems in real time or even predicting them, proposing optimized solutions, and simulating their outcomes. Specific impact points in logistics are described, contrasting the processes in current versus intelligent ERP. The digital enterprise has deep implications in all areas of business, but in this paper we will focus on broadly defined logistics processes, including materials planning, purchasing, production, quality control, plant maintenance, sales processes, and transportation.

The sources of advantage of the digital enterprise are derived from the availability of additional sources of structured and unstructured data, faster computing speed allowing the use of advanced algorithms in real time, including artificial intelligence and machine learning tools both inside and outside the ERP system. While enhanced computing speed allows the use of additional deterministic (e.g. material requirements planning) and stochastic (e.g. forecasting) models, artificial intelligence allows the discovery of hidden relationships in the data that can reveal unknown facts both inside and outside the ERP system.

The transition toward the digital enterprise implies an escalation in complexity in ERP systems, with more data and the generalized use of advanced heuristics until recently only known in the academic literature and advanced firms. Lack of understanding of these heuristics by implementers or users of the system can lead to errors in configuration and master data which until now have been difficult to detect. These errors include the selection of sub-optimal workflows or models, resulting in decreased logistics performance. The paper will explore how artificial intelligence tools can help to uncover such errors and the impact of the digital enterprise on human skills.

# Integrating DLT (Distributed Ledger Technology) into Cloud Trading Platform

---

Regular Session

---

*Dr . yang lu*<sup>1</sup>

*1. Visiting Assistant Professor*

Cloud computing is an emerging technology that offers rich resources and services through the network. Most cloud providers adopt centralized mechanisms to price and to allocate cloud resources. Meanwhile, cloud consumers pay more attention to Quality of Service (QoS), such as availability and reliability, which measures how well a service is performed. This paper proposes a hybrid decentralized QoS-based P2P cloud trading system that can efficiently allocate resources according to customers' QoS preferences. A relationship between QoS and price is established. Accompanying with P2P requirements, we implement continuous double auction for trading cloud services. This research offers a strong method to merge cloud industries with informatics systems.

# INTELLIGENT NETWORKS: IMPLICATIONS FOR RURAL CITIZENS IN INDIA

---

Regular Session

---

***Prof. Sameer Prasad*** <sup>1</sup>

*1. University of Wisconsin-Whitewater*

In the developing world, self-help networks were initially formed to provide credit at the micro-enterprise level. Today, these networks have evolved, and can now offer a range of services including supporting integrated supply chain networks for farmers to the delivery of essential services such as primary healthcare. These networks are adaptive and reflect the complex and non-linear realities experienced by the populations. In this research, we first describe the nature of complex and non-linear environments in rural settings, and the importance of accounting for such environment in attempting to find solutions for the villagers. Secondly, we explore different forms of informal networks through the lens of social capital theory. Finally, we suggest how Artificial Intelligence (AI) can model informal networks and provide insights into finding enhanced solutions for villagers.

In rural communities, the available infrastructure can be view as frayed and riddled with holes.

Villagers need to overcome these difficulties by navigating around frayed services and, at times, plugging “holes” in the infrastructure or navigating around gaps in information flow. Plugging “holes” or navigating around gaps requires villagers to work in groups to solve complex problems be open to non-linear approaches. For example, villagers can form Self Help Groups (SHG), or networks of villagers (generally women) that provide a mechanism for aggregating financial resources, repayment services, and a feedback loop on business plans. These groups can also be a conduit for health care in terms of providing information, access to medication, and even transportation. Groups can be viewed through the lens of social capital theory; including the structural, relational, and cognitive social capital that they rely upon.

In this research, we examine the ability of groups in rural settings to solve complex problems. To model such behaviors, we examine the applicability of Artificial Neural Networks (ANN) in predicting the relationships between several inputs (e.g., measures of structural, relational, and cognitive social capital) with several relevant outputs (e.g., health care metrics). Neural networks provide a high degree of flexibility because they are not constrained by linear assumptions. Between the input and output layer, there can be one or more hidden layers. In many typical applications, a single hidden layer is sufficient, but if complexity grows, additional layers can be added. In this study, we plan to use the Back Propagation (BP) method to train the network. In non-linear environments, ANN outperforms standard linear methods such as regression.

In this research, we detail how action research, in conjunction with Sodhana Charitable Trust, is being braided with possible AI modeling to develop solutions at the ground level.

# Natural Language Processing, Data Visualization, and the Mueller Report

---

Workshop

---

***Dr . Mike Mitri*** <sup>1</sup>

*1. College of Business, James Madison University*

This presentation discusses the use of open source software libraries for extracting key story elements from a textual narrative and displaying them in an intuitive and interactive manner to users via a set of visualizations. The first library is Stanford's CoreNLP, a Java API that provides natural language processing (NLP) services such as sentence recognition, tokenizing, parts-of-speech identification, dependency parsing, named entity recognition, coreference resolution, and temporal tagging. The second is D3, a JavaScript API built on scalable vector graphics (SVG) which provides powerful data visualization capabilities. Google Charts and Google Maps APIs are also used. An application called Story Analyzer was developed using these APIs. NLP-based application development involves challenges, limitations, and ambiguities. These issues, and accompanying workarounds, are discussed in the context of official impeachment-related documents, including the Mueller Report, opening statements from impeachment witnesses, and other related narratives.

# Pattern recognition in solicited policy-based public comments: Challenges and opportunities

---

Regular Session

---

***Dr . Bola Ekezie*** <sup>1</sup>

*1. Fayetteville State University*

This study aims to identify challenges in analyzing solicited public comments for policy decisions and proposes ways to optimize models used to derive patterns.

Public comment has been and continues to be an important part of the government rule and policy decision-making process. Often, there is a required period for the public to submit their inputs on proposed policies. This period affords the public opportunity to participate in shaping the policies and rules by submitting written comments that reflect their opinions and views. The preferred method of solicitation and collection of public comments is through an online web form that is primarily unstructured and free-flowing. Text analysis value is in its capability to identify patterns and derive structured information from text data, but there are increasing challenges in analyzing public comments. The criticism of public comments as a means of engaging the public is centered on the high potential for fraudulent and automated system submitted comments. If public comments will be credible, fraudulent comments and noise in the data must be systematically identified and excluded.

We analyzed the public comments collected for North Carolina's Medicaid Reform Demonstration Amended Application in 2016. The Medicaid Reform application intends to implement managed care transformation for Medicaid beneficiaries and benefits for sub-group populations. We used Natural Language Processing (NLP) technique to identify patterns, obtained the similarity score to identify and exclude potential copies, developed concept link diagram for key concepts in the Medicaid reform, and correlation of sentiments with key concepts. In conclusion, substantial cleaning of public comments data is necessary to ensure information derived is credible and reliable. Sentiment analysis of the entire comment as a unit may yield erroneous results. Segmenting the comment to unique sentences for analysis may be necessary.



# Persistent Homology Based Data Analytics: Detecting Anomalies in Android Malware

---

Regular Session

---

*Dr . Paul Schrader <sup>1</sup>, Dr . Rami Alroobi <sup>1</sup>, Dr . Md Karim <sup>1</sup>*

*1. Southern Arkansas University*

## **Persistent Homology Based Data Analytics: Detecting Anomalies in Android Malware**

*Paul Schrader, Rami Alroobi, Md Karim*

*Department of Mathematics and Computer Science*

*Southern Arkansas University*

We present the preliminary results of a persistent homology application for identifying anomalies in an Android malware dataset. The purpose of this study is not to detect new malwares but to analyze the relationships among reported malwares ultimately assisting analysts to better understand malware trends and develop necessary antidotes. Persistent homology (PH) is a novel data analytics tool that summarizes a dataset using its topological properties which remain stable under small perturbation of the input data. A significant shift in PH output can be attributed to a characteristically significant modification in the input data. PH, therefore, has high potential as an effective anomaly characterization tool, and as such should be explored. Presented results show that while PH indicates the inclusion of a new malware sample in a dataset, determining the nature of the added malware sample (i.e., whether the new sample is a variant or a new species) may not always be conclusive. This finding is explainable since cross-pollination is a common phenomenon that happens during the birth of a malware (e.g., malware authors often borrow code from different existing malware species for use in their own creation). Malware relationships can be characterized more precisely through phylogenetic association. Existing phylogenetic methods use feature-level similarity (or distance) scores to determine malware-to-malware relationships. Preliminary results indicate that PH is a strong candidate for identifying some novel aspects of phylogenetic association. The current study uses low-informative bytecodes as features for their simplicity. Our future PH analytic strategies include semantically enriched higher level features in our follow up study and we expect to see improved results.

# PREDICTING ALL-CAUSE 30-DAY HOSPITAL READMISSIONS: A FIRST STEP IN MODEL BENCHMARKING

---

Regular Session

---

*Dr . Stacey Mumbower <sup>1</sup>, Dr . Ronda Hughes <sup>1</sup>*

*1. University of South Carolina*

Utilizing data from a large randomized controlled trial that added risk assessment tools for nurses to use with patients as part of the discharge planning process, we benchmark models that predict all-cause 30-day hospital readmissions. We compare the performance of several commonly used machine learning models against binary logistic regression models and find that machine learning results in a modest increase in predictive ability.

A logistic regression model that incorporates only explanatory variables from the widely-used LACE Index Scoring Tool performs the worst with a test AUC of 0.709. A second logistic regression model that incorporates a more diverse set of variables results in a small increase in predictive ability (1.3% increase in AUC). The neural network, gradient boosting machine, and random forest all perform similarly with test AUCs of 0.736, 0.736, and 0.735 respectively (representing a 2.3 – 2.5% increase in test AUC over that of the second logistic regression model). The best overall model is an ensemble model with a test AUC of 0.743 (a 3.5% increase in test AUC over that of the second logistic regression model, and a 1% increase over the best individual model).

In a secondary analysis, we investigate predictive ability of the information collected as part of the new risk assessment tools for nurses. Prior analysis of the randomized trial found the new tools to be effective in some hospital units, significantly reducing readmissions. However, using information from these new tools as explanatory variables in the models results in only a slight increase in predictive ability (0.4% increase in test AUC).

As part of the model benchmarking process, we also compare predictive ability across different subsets of the data. We find that AUCs vary by hospital and type of diagnosis. These results have implications for using the predictive models as part of the hospitals' discharge planning process.

# PREDICTING INDEPENDENT SALESFORCE PERFORMANCE: USING PREDICTIVE MODELS OF SUCCESS FOR DIRECT SELLING MICRO-ENTREPRENEURS

---

Regular Session

---

*Dr . Murat Adivar <sup>1</sup>, Dr . Caroline Glackin <sup>1</sup>*

*1. Fayetteville State University*

This research addresses essential questions for direct selling organizations (DSO) on how to predict and foster the success of independent sales representatives. It employs predictive analytics to create models for recruits and existing representatives.

The study analyzes the proprietary 2018 National Salesforce Survey commissioned by the Direct Selling Association. It addresses vital considerations for firms in the recruitment, training, and employment of independent sales representatives for organizations that rely on contractual salespeople for revenues and growth. It considers the specific case of 79 direct selling organizations and how to predict and increase the earnings success of independent representatives, thereby ensuring increased organizational revenues.

Employing predictive analytics, it creates models for recruits and existing representatives. Several classification methods (Fit Nominal Logistic, Naïve Bayes, K-Nearest Neighbors, Boosted Trees, Bootstrap Forest) are implemented to develop a best-performing machine learning algorithm to predict the financial success of a direct selling candidate based on predictors available at the time of recruitment. In addition, we use these methods to predict the productivity of active representatives. Our target is the representatives that are most likely to make more than \$10,000 annual net income from their direct selling efforts, the threshold commonly used in the channel, reflecting substantially higher income for the DSOs that recruit them.

The study finds that allocated time for direct selling, agility to find new customers, gender, and adopting direct selling as a career play a vital role in predicting sales success for individuals entering direct selling. The highest performing representatives are characterized by time invested, the experience of direct selling, recruitment, tenure, and use of technology.

This research suggests that DSOs planning to maximize the efficiency of recruiting, training, and other resources while generating optimal sales levels may want to implement some form of pre-contracting questionnaire to sort the representative and his/her potential for performance and to provide targeted support. By using lifts, the study also quantifies the positive impact of using predictive models in hiring, training, and advancement of independent sales representatives.

# Predictive Analytics using Machine Learning for Electronic Health Records

---

Regular Session

---

*Ms . Arjumand Fatima <sup>1</sup>, Dr . Hayden Wimmer <sup>1</sup>, Dr . Cheryl Aasheim <sup>1</sup>*

*1. Georgia Southern*

Machine learning algorithms can play a vital role in different organizations such as healthcare. Using machine learning algorithms can impact the healthcare industry tremendously by predicting diseases outbreaks, mortality rates, monitoring risks, and many other factors. Being able to monitor and control these factors can help save the industry cost, and provide for better resource allocation. This paper aims to analyze different machine learning approaches for predicting hospital length of stay (LOS) using electronic health records (EHRs). The use of a machine learning model such as Logistic Regression(LR), Decision Trees and Neural Networks (NN) will be used along with python and SPSS to preprocess and prepare the data for prediction of hospital LOS. The results will show how the preprocessing phase of data can directly influence your results. Based on preprocessing of data, results could yield to a higher or lower accuracy of prediction models of patients' length of stay in the hospital. Predicting LOS can better assist and provide patients with the proper resources and help reduce hospital cost and provide for a better treatment for the patient. In conclusion, machine learning algorithms can be a vital part for the healthcare industry. It can help save cost, reduce failures and delays in medical settings and impact the healthcare industry tremendously.

---

# R&D PROJECT EVALUATION WITH KNOWLEDGE-BASED SYSTEM

---

Regular Session

---

*Mrs . gabriella toth-haasz <sup>1</sup>, Prof. Zoltan Baracscai <sup>1</sup>*

*1. SzEEDs Doctoral Program, Széchenyi István University*

When an R&D project is launched there are explicit and implicit aspirations as an attempt of project managers to achieve those results along which a project can be successful. Based on experience of previous projects, all these aspirations can be articulated with a commonly accepted and familiar vocabulary as attributes and its values.

In this study, during the Knowledge Engineering (KE) process Knowledge Acquisition (KA) occurred while knowledge engineer attempted to acquire the project managers' explicit and tacit knowledge. KA proved to be an adequate way of data collection through semi-structured interviews with project managers in order to build Knowledge Base from their projects as cases. The collected knowledge elements were inserted into a Knowledge-Based System (KBS), which is able to handle these soft data to find the most informative attributes. KBS used is advanced for systematizing prior knowledge and experience and it can transform them into symbols to develop models for different scenarios. As a result of the KE process a knowledge base was built with 16 relevant attributes and 3 or 4 values were assigned to each of them.

A basic question of the study is that whether the applicability of a KBS can be extended to this way of project evaluation? Within this, authors investigate in this research that which are the most informative attributes in applied engineering R&D projects of a higher education institute, and what is the logical relationship between them? Validation is presented through an application with examination of 21 R&D projects: finally a model was built with the three most informative attributes and three logical rules. The following relevant rules were uncovered: (1) If the "project manager's experience in the domain/topic" was "master" level but "the team leader's relationship to the topic" was "forced to commit" then the result of the project was "financially failed"; (2) if "project manager's experience in the domain/topic" was "master" or "advanced" level and the "the team leader's relationship to the topic" was "accepted" then the result of the project was "according to agreement"; (3) and it is very interesting to see that if "project manager's experience in the domain/topic" was "beginner" level and his or her "experience in coordination" was also "beginner" level, BUT "the team leader's relationship to the topic" was "enthusiastic", the result of the project was "according to agreement".

Using of these rules can have key contributions to strategic planning in prospective academic project management and those can be starting point of re-definition of the role of academic project manager in university D&R labs. The findings describe both the limits and abilities of the project organization by which the decision maker can identify core competencies or even unsubstantiated dependencies on external resources.

# THE MULTI-INTELLIGENT AGENT GROUP DECISION SUPPORT SYSTEM (MIA-GDSS)

---

Regular Session

---

*Mrs . Josephine Stanley-Brown <sup>1</sup>, Dr . Heinz Weistroffer <sup>1</sup>, Mrs . Ramandeep Sandhu <sup>1</sup>*

*1. Virginia Commonwealth University*

The complexities of group decision making are significant, especially today with the size of data and the difficulty for groups to locate, access, filter, and integrate accurate and high-quality information. Additionally, the fact that different members have different levels of expertise and knowledge makes the process even more challenging. GDSSs assist group members with communication, decision analysis, and discussions; however, in their current state, they are becoming less and less effective and efficient. They can no longer just be standard support systems; they must integrate and offer users an element of (artificial) intelligence that can truly address the complex issues of the group decision-making process. So how can these issues be addressed? One solution might lie in the integration of intelligent software agents or intelligent agents. As such, this paper will propose a high-level conceptual framework called the Multi-Intelligent Agent Group Decision Support System (MIA-GDSS), which will attempt to address the question: How can multi-intelligent agents be used to make the group decision-making process more effective and efficient?

# Variable Fixing Hybrid Heuristic for 0-1 Mixed Integer Programming Problems

---

Regular Session

---

*Dr . Jeremy North <sup>1</sup>, Dr . ROBERT NAUSS <sup>2</sup>*

*1. Murray State University , 2. U of Missouri-St. Louis*

Combing heuristic algorithms with “black-box” solvers is an active field of research. In this work, we summarize the literature of hybrid heuristic algorithms that incorporate state-of-the-art optimizers like GUROBI or CPLEX, with a particular focus on approaches that implement variable fixing procedures.

These algorithms typically seek to reduce the “core” of problems that can’t be solved to optimality within a reasonable amount of time. Solving these reduced problems can produce good solutions that aren’t provably optimal to the original problem.

A synthesis of the existing heuristic and metaheuristic algorithms for variable fixing in 0-1 mixed integer programming will be provided with research opportunities identified. We will propose a new variable fixing heuristic algorithm within a hybrid heuristic framework employing a state-of-the-art optimizer. Preliminary results will be provided on benchmark datasets for the p-median problem.

**Analytics, Big Data,  
Business Intelligence,  
Data Mining, Statistics  
and Expert Systems -  
Papers**



## A DATA ANALYTICS MODEL FOR EXTENDED REAL ESTATE COMPARATIVE MARKET ANALYSIS

Binu Jacob, Seidenberg School of CSIS, Pace University, Pleasantville NY, bj47819p@pace.edu  
Charles C. Tappert, Seidenberg School of CSIS, Pace University, Pleasantville NY, ctappert@pace.edu

### ABSTRACT

As part of real estate sales, a comparative market analysis is an analysis that is provided to most of the prospects and customers. Currently, this market analysis typically includes only nearby properties and is rather superficial. In the case of an investor, the list of properties in the analysis should include properties beyond the nearby area. In this study, data analytics tools for clustering, classification, and recommendation models were explored with the aim of producing a larger and more detailed list of properties to resolve these issues.

### INTRODUCTION

In the real estate market, buyers and sellers usually receive a Comparative Market Analysis (CMA) from their agents and this includes only nearby properties that are manually selected in most cases [1]. Investors who want to know similar information from different cities in a state currently must depend on multiple real estate agents to get this information which is also performed manually by various real estate agents. To provide better insight to the investor, it would be valuable if there is a data analytics solution that could find the comparable properties in many cities in a state and also predict the future prices and/or rental estimates of the found comparable properties (a graphical representation can be seen in Figure 1). In addition to this, a person or an agent has to go through many factors that are involved in the short listed properties to give a suggested properties list to the prospect.

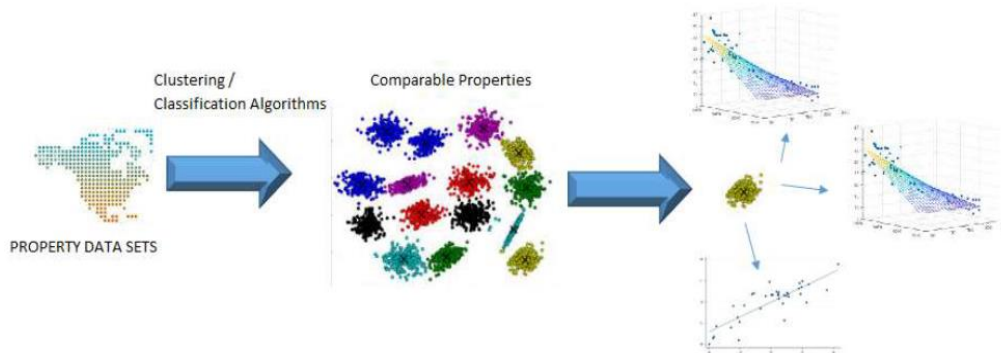

Figure 1. A Graphical Representation of Extended CMA.

Currently online and offline solutions that are aiding the process of filtering real estate listing as per the user selected or provided criteria are handled mainly by online service providers and none of them are effectively using a data analytics approach or machine learning algorithms to tackle the situation. A software solution or an algorithm that can help in automatically filtering the results intelligently considering all the facts can be very helpful. A data analytics model can be a solution for the above mentioned problem.

### **Background**

Whenever a client receives comparative market analysis from an agent, it will be prepared from comparable properties from the nearby areas. It is an important factor from the agents' point of view when preparing CMA (comparative market analysis) to include nearby properties. Most of the agents has access only to one or two real estate associations or they will be subscribed to only minimal amount of multiple listing providers. In addition to this, price of the real estate is considered largely depend on the sales and price of the nearby properties [1, 7, 8]. But what happens when an investor consider purchasing a property that can be anywhere in a large area that can span areas such as north east or south west etc. This kind of search is not limiting to one agent. Then the users have to depend on multiple agents to get the property choices available to them according to their criteria in which all of these agents provide the nearby properties in their respective geographic area. Another way to get this is to depend on a multi-state or nationwide realtor company such as century 21 or Coldwell banker in which they assign many agents to come up with a list of properties from different places. However this also requires co-ordination between agents and arranging and rearranging multiple reports provided by multiple agents.

In some cases software may be available to give an automatic comparison or nearby properties but in some case it will be manually handpicked by agents. If the investor tries another way and searches himself online websites such as Zillow.com, Realtor.com, Trulia.com etc., still their searches mainly done by inputting a property and the site then will provide a list of properties nearby to compare. Here also it can be a tedious task to come up with properties that are matching or comparable to the selected choices of the investor [17, 4, 3]. The search itself can be a huge task. Then they have to spend additional time to consider various factors of the properties given in the list and make a choice. Instead of these time consuming and cumbersome methods of selecting a property for an investor, it will be an easy process if there is a data analytics approach using a machine learning or deep learning model that provides or suggests a list of properties in any given geographical area. The list of properties can be input to the model to train it and after clustering or classifying according to correlating features, it can be submitted to a recommendation model which will analyze various factors and provide best options to the investor according to a recommendation score that the model is producing.

### **Extended Comparative Market Analysis**

While comparative market analysis takes nearby properties to come up with a list of property that are close enough to present to client, Extended Comparative market analysis's main target audience is investors. While residential buyers mainly concentrate on a specific geographic area called nearby area, investor's property search area doesn't need to be limited to nearby area. Investors can buy property anywhere in the

nation wherever a close match can be found. This close match can be in the sense of price, return on investment, rent, easiness to rent, easy to sell etc. etc. depending on the investor. In other words, comparative market analysis produces a list of properties that are nearby while Extended Comparative Market analysis produces a list of properties that are nearby and beyond nearby area depends on the user's choice of geographical area. This geographic area can be extended to anywhere in the nation where the investor's area of business. Note that both comparative and extended comparative market analysis make use of sold price [1, 7, 8]. However, there are other factors that depend on the pricing and value of real estate ownership when it goes beyond nearby area. Extended Comparative Market Analysis includes properties in nearby areas as well as beyond nearby areas. The beyond nearby areas can be anywhere where comparable economic, financial, marketing conditions can come a close match.

### **Nearby area**

Nearby area is a concept that is used in traditional comparative market analysis as well as all real estate similar property searches. A nearby area generally is a geographic area that is close to the user's interested property location. However, this nearness can vary depending on user requirements. It can be a small area of a development site, or a large area that includes one or two zip codes. In addition, a nearby area can even include a city or a specific school zone. The nearby area can be dictated by many factors. It can be a user defined area, it can be a small development, and it can be an area around the property that are enough similar properties can be found. It can be an area coming under a zip code or multiple zip code. It can include a city where the property resides. However, in the case of Extended Comparative market analysis, the above mentioned geographic area concept in ordinary comparative market analysis is ignored and the selection of the properties can be anywhere depends on the data involved.

### **Technologies and Platforms**

Extended Comparative Market Analysis is mainly using Clustering, Classification, and Regression Analysis machine and deep learning algorithms to come up with its final list of properties. The software technologies such as TensorFlow, Keras, Python libraries, R, Hadoop, and Spark are used in various steps of the study. IBM Bluemix, AWS, Google Cloud/Colab, Anaconda, Weka etc. were also used as part of the study in different steps. Resilient Distributed Datasets (RDD), Numpy Arrays, Pandas DataFrames and comma separated value files were used to handle the data during the processing of the software solution.

## **LITERATURE REVIEW**

There are a lot of documents available for house price prediction. However almost all of them are not giving priority on a classification or clustering projects with an intent to come up with properties beyond nearby area. A few documents explore the correlation among features that are usually considered along with house prices such as square feet, number of rooms, number of beds, price etc. Some of the literature review done are given here. Sifei Lu et al investigate hybrid regression techniques for house price prediction. A practical and composite data pre-processing and creative feature engineering method is examined in this paper [13]. Debanjan Banerjee et al is trying to predict the house price direction using

machine learning techniques in their research. This research work applies various feature selection techniques such as variance influence factor, information value, principle component analysis and data transformation techniques such as outlier and missing value treatment as well as box-cox transformation techniques. In this study, the performance of the machine learning technique is measured by accuracy, precision, specificity, and sensitivity [2]. Parasich Andrey Viktorovich et al. describing regression methods of machine learning they used in their work. In this work they used classic machine learning algorithms and their own original methods to predict the sale price [11]. S. Zhou, L. Cao and Y. Li has done a study on real estate investment environment using support vector machine. Natural environment, economic environment, policy environment, social culture environment features were considered for this study [15]. Huawang Shi, in his paper titled “Determination of Real Estate Price Based on Principal Component Analysis and Artificial Neural Networks” uses principal components analysis method of multi-dimensional statistical analysis as well as artificial neural networks to determine the price of real estate [5]. Hu Xiaolong and Zhong Ming studied neural network's ability to resolve the problems associated with prediction of real estate price [6].

## METHODOLOGY

### **Data Collection and Preparation**

In various steps of the study, different sub sets of the same data set have been used. The raw dataset with forty five features has been subjected to various data preparation and visualization steps. The features with better correlation have been selected for the data set for the main study. The comma separated value file of the raw data set allowed to manipulate the file using Excel. However, after initial data preparation steps, the source code of the project has included many steps that addresses the noise issues of the data set. Outlier values are removed from the data set after visualizations. Many of the rows contained spaces in the original raw data set have been removed. Null values also removed from the data set to further achieve a better cleanness of the data. Atomdata.com [12] is the main source of the data used in this study.

### **Data Visualization**

Data visualization is done using Python code in this study. Matplotlib, Seaborn, and Pandas framework are mainly used to create graphs. Univariate analysis has been done by creating one dimensional histogram using Pandas framework. One dimensional histogram (Figure 2) and density plots are created to visualize continuous numeric attributes.

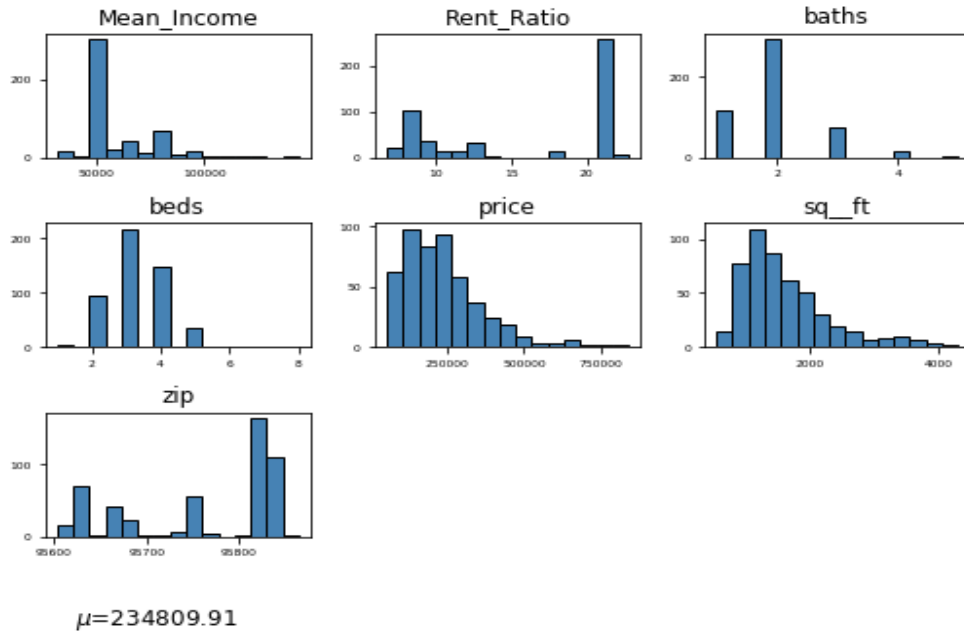

Figure 2 One Dimensional Graphs

Bar plots were created to visualize discrete categorical data attributes. To do multivariate analysis, pairwise correlation matrix and heatmap have been created. A multidimensional scatter plot with zip, price, and square feet was created to visualize data. In addition to this, size and color was used to represent number of baths and number of beds in the same graph.

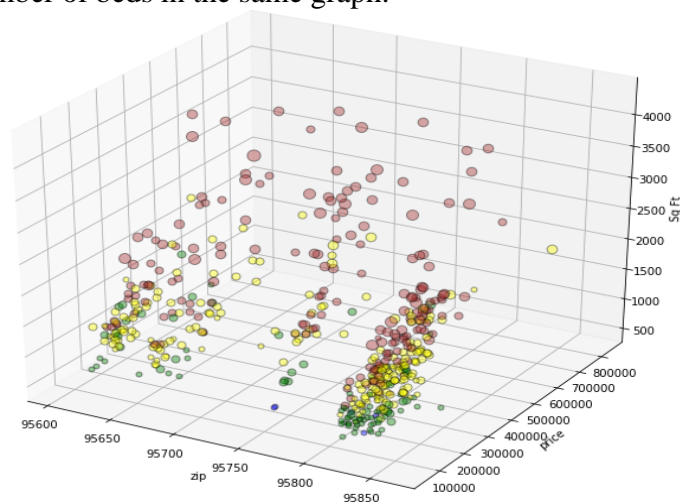

Figure 3 Graph 5D

This made it as 5d graph (Figure 3). Pair-wise plots (Figure 4) against each attributes visualized the data effectively when it used along with correlation heatmap [16].

**Exploratory Data Analysis**

The housing data set used has more than forty columns. However, after the data preparation, the columns selected for this study are street, city, zip, state, beds, baths, square feet, price, type, Mean Income, Inventory, rent ratio, and various other ratios and synthetic features that are derived during the execution of the code. Various one dimensional and multi-dimensional graphs including a five dimensional graph were created and studied.

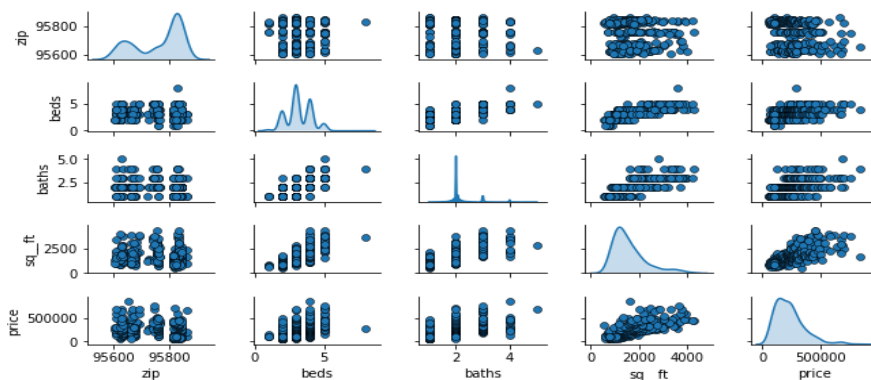

Figure 4 Pair-wise Plots

Histogram square feet vs price (Figure 5) and a density plot for square feet vs price (Figure 6) shows a normal skew with minor issues with some zips. A scatter plot was created using zip, price, square feet data, beds, and bath. The color and size was used to show beds and baths in this graph. The graph has clearly shown the distribution of properties.

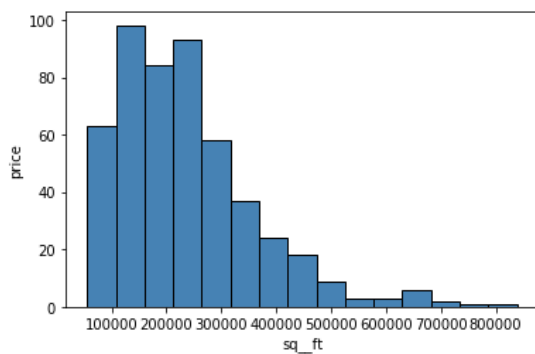

Figure 5 Histogram square feet vs price

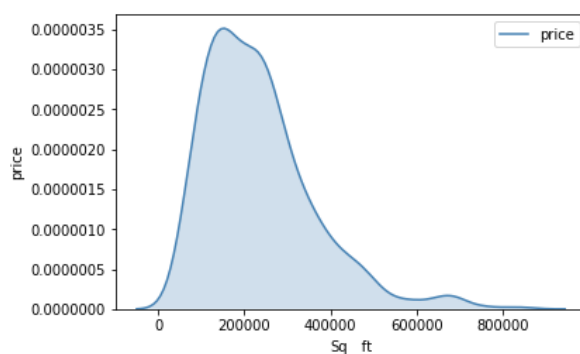

Figure 6 Density plot for square feet vs price

As zip is not a major factor in the model, no data was removed because of the minor abnormality in the bell curve. Cluster graphs visualized the clustering of data by different algorithms such as K-Means and Gaussian Mixture Clustering (Figure 7, 8).

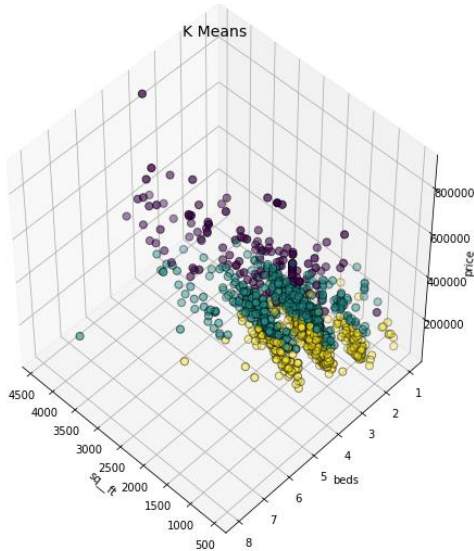

Figure 7 A Sample K-Means Clustering Graph Created During the Study

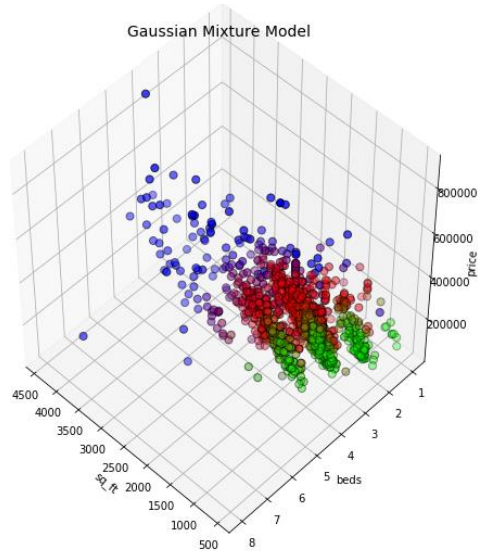

Figure 8 A Sample Gaussian Mixture Clustering Graph Created During the Study

**Feature Engineering**

Relationship between available features were studied in the data set. A correlation heatmap (Figure 9) was used to find the correlation between features. Street, Latitude, and Longitude correlation was poor and hence not used in almost all of the algorithms. The percentage of correlation between square feet and price was expected to be significant.

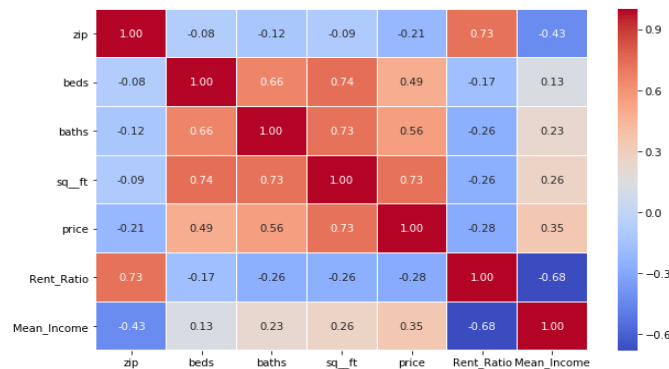

Figure 9 Correlation Heatmap

However in the available data the correlation between square feet and price was only up to thirty one percentage. At the same time, there is a better correlation percentage between other features such as beds, baths, and square feet. Therefore beds, baths, and square feet were also used in a significant way in the algorithms used.

## MACHINE LEARNING

Machine learning algorithms are implemented to the task of filtering the property lists according to various criteria in different levels of processing and finally to come up with a small list of matching properties. Extended Comparative market analysis methodology involve many steps of grouping or clustering based on various types of features. As the model has to come up with a list of properties that are beyond the nearby area, geographical features are ignored when the clustering or grouping takes place and filter properties. However, the algorithm has to find the matching economies or locations based on the economic and financial features and its relationship to price. Once this step is done, the algorithm gives importance to real property features and find its matches. After the real property features then comes the amenity and other features. In the category of other features, anything specific to geographical identifiers are ignored to avoid the grouping based on geographical boundaries. Figure 10 and 11 illustrates the steps as a flow chart.

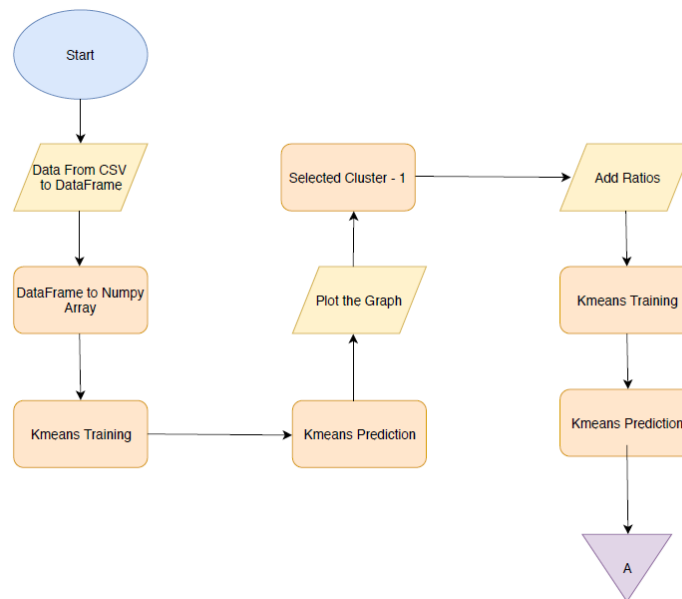

Figure 10 Flow Chart – 1



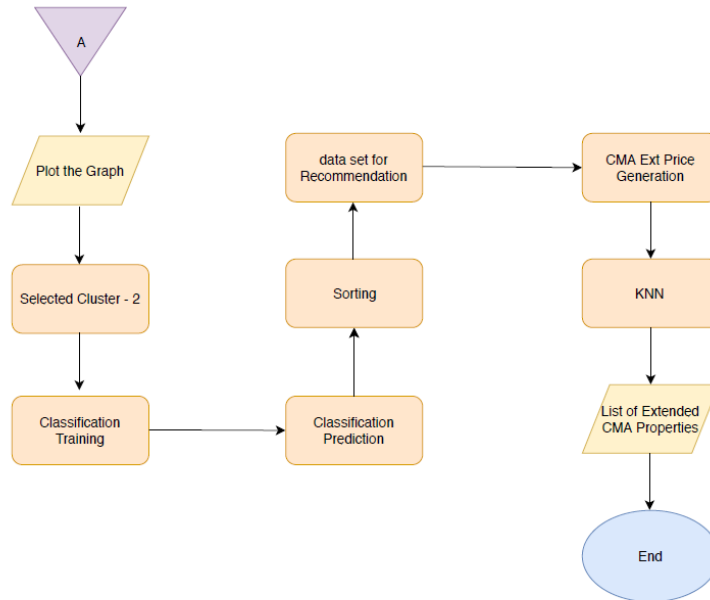

Figure 11 Flow Chart 2

## Clustering

The clustering algorithm used in the model is K-Means clustering which can show us possible cluster (or K) there are in the dataset. Sample Cluster formations created during the code execution is given here in Figure 13 and 14. The algorithm then iteratively moves the k-centers and selects the data points that are closest to that centroid in the cluster [14]. A sample of data with cluster column is shown in Figure 12.

1. Initialize **cluster centroids**  $\mu_1, \mu_2, \dots, \mu_k \in \mathbb{R}^n$  randomly.
2. Repeat until convergence: {
  - For every  $i$ , set
 
$$c^{(i)} := \arg \min_j \|x^{(i)} - \mu_j\|^2.$$
  - For each  $j$ , set
 
$$\mu_j := \frac{\sum_{i=1}^m 1\{c^{(i)} = j\} x^{(i)}}{\sum_{i=1}^m 1\{c^{(i)} = j\}}.$$

selected\_cluster - DataFrame

Index	zip	beds	baths	sq_ft	price	Rent_Ratio	Mean_Income	Inventory	garages	type	cluster
75	95758	4	2	1596	221000	8.69	78535	314	0	1	0
76	95835	2	2	1341	221000	20.98	48226	936	0	1	0
77	95624	5	3	2136	223058	8.69	78535	314	0	1	0
78	95624	4	2	1616	227887	8.69	78535	314	0	1	0
79	95823	3	2	1478	231477	20.98	48226	936	0	1	0
80	95670	3	2	1287	234697	8.87	66104	176	0	1	0
81	95621	4	2	1277	235000	12.3	59953	155	0	1	0
82	95833	4	2	1448	236000	20.98	48226	936	0	1	0
83	95829	4	3	2235	236685	20.98	48226	936	0	1	0
84	95655	3	2	2093	237800	9.57	106418	214	0	1	0
85	95673	3	2	1193	240122	12.24	71446	79	0	1	0
86	95757	3	2	2163	242638	8.69	78535	314	0	1	0
87	95828	3	2	1269	244000	20.98	48226	936	0	1	0
88	95820	3	1	958	244960	20.98	48226	936	0	1	0
89	95624	5	3	2508	245918	8.69	78535	314	0	1	0
90	95621	3	2	1305	250000	12.3	59953	155	0	1	0

Figure 12 Pandas DataFrame with First Cluster Column

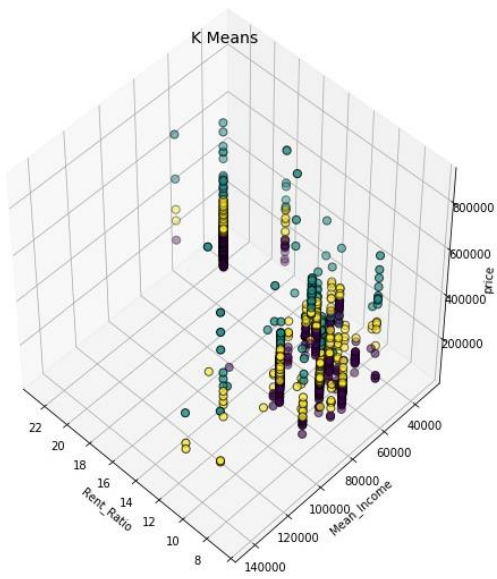

Figure 13 A cluster Graph Created During the Frist Cluster Formation

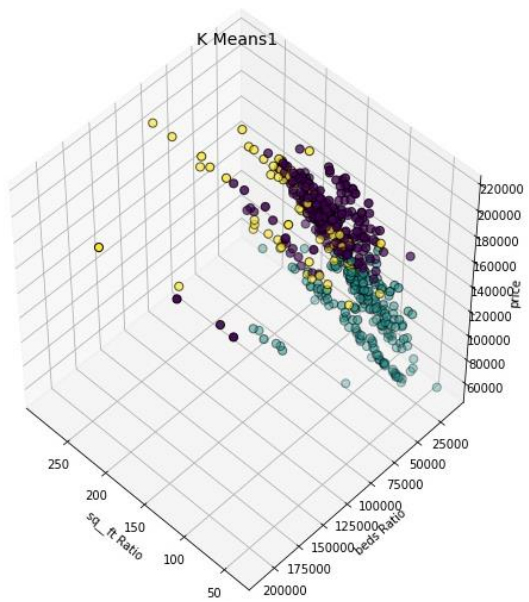

Figure 14 A cluster Graph During the Second Cluster Formation

The graph shown here in Figure 15 is created during the execution of the Extended CMA code and the optimal value of  $k$  is 3 and thereby 3 is the number of clusters used as value of  $k$  in the code [10].

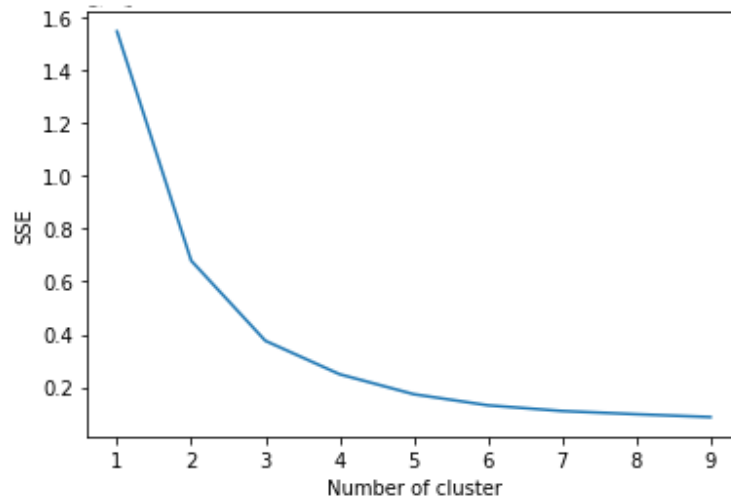

Figure 15 Scikit K-means clustering Performance Measure

### Classification

A neural network for binary classification was used in the study. There are three input variables and one output variable. According to the heatmap created using the correlation for the dataset and the seaborn pair plot showed the relationship among the variables and were fit for the use. Keras sequential model is used to build the neural network. After standardizing the input feature, divided the data into training and testing data set.

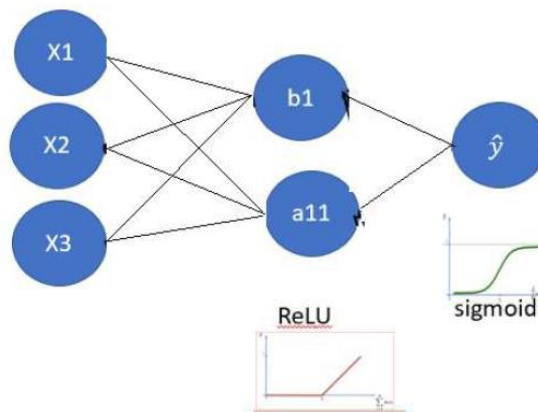

Figure 16 Neural Network Layer

A graphical representation is shown here that explains the neural network layer (Figure 16). As we have 3 input features and one target variable, there is 1 Hidden layer and the hidden layer has 3 nodes. ReLu is the activation function for hidden layer. As this is a binary classification problem, the study used sigmoid as the activation function. Dense layer implements

Output = activation (dot (input, kernel) + bias)

Kernel is the weight matrix. Kernel initialization defines the way to set the initial random weights of Keras layers .As this is a binary classification problem, used binary\_crossentropy to calculate the loss function between the actual output and the predicted output. To optimize the neural network, Adam is used. Adam stands for Adaptive moment estimation. Adam is a combination of RMSProp + Momentum. Momentum takes the past gradients into account in order to smooth out the gradient descent.

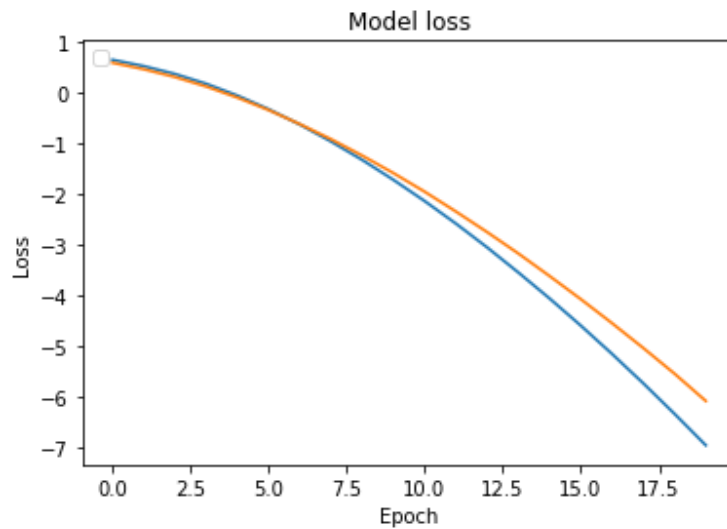

Figure 17 Loss Vs Epoch Graph for Training and Testing Data

The model used a batch size of 10. This implies that we use 10 samples per gradient update. Iterates over 20 epochs to train the model. An epoch is an iteration over the entire data set. A graph is drawn to show the model loss (Figure 17). Number of epoch is shown on the x axis and loss is shown on the y axis. Both training and testing loss is shown as two separate lines in the graph [9,16].

### **KNN Recommendation**

The final algorithm used in the model for recommendation is K-nearest neighbors (KNN). K-nearest neighbors is a supervised algorithm that is easy to implement for the purpose of recommendation systems.

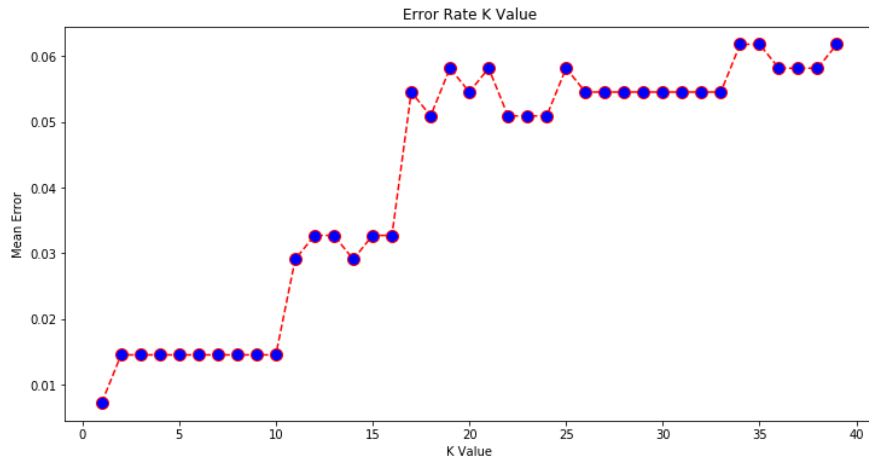

Figure 18 Mean Error Vs K value graph

Sklearn Nearest Neighbors library is used in the model to do the K-nearest neighbors algorithm to recommend the properties. A graph is drawn to show the model performance (Figure 18).

## RESULTS

The model successfully produced a list of comparable properties (Figure 19) beyond the nearby area. The model effectively picked similar economies and compared and matched various features such as real estate features, financial features, Amenity features, different ratios to produce the final results. The order and the purpose of clustering, classification and recommendation algorithms used in the solution was effective which is verified by the results produced.

A clustering model alone was not enough to produce the output and hence methodology included a classification and finally a recommendation model to come up with the final result. Each model has used different features and relationship to optimize the result. When the clustering models used economic and financial feature in the beginning step, and basic feature ratios in the second step, classification used basic real estate features. At the same time recommendation model mainly made use of square feet, beds, bath, and price to come up with list of properties that are comparable to the user selected property.

street	9949 NESTLING CIR	street	6850 21ST ST	street	Liberty
city	ELK GROVE	city	SACRAMENTO	city	Bensalem
zip	95757	zip	95822	zip	19020
beds	3	beds	3	beds	1
baths	2	baths	2	baths	2
sq_ft	1543	sq_ft	1446	sq_ft	1265
price	275000	price	275086	price	250000
Rent_Ratio	8.69	Rent_Ratio	20.98	Rent_Ratio	10.5
Mean_Income	78535	Mean_Income	48226	Mean_Income	89518
Inventory	314	Inventory	936	Inventory	159
garages	0	garages	0	garages	0
type	1	type	1	type	2
cluster	0	cluster	0	cluster	0
cluster1	0	cluster1	0	cluster1	0
Classification Score	1	Classification Score	1	Classification Score	1
psq_ratio	178.224	psq_ratio	190.239	psq_ratio	197.628
CMA_Ext_Price	254122	CMA_Ext_Price	238147	CMA_Ext_Price	208337

street	2678 BRIARTON DR	street	6326 APPIAN WAY
city	LINCOLN	city	CARMICHAEL
zip	95648	zip	95608
beds	3	beds	3
baths	2	baths	2
sq_ft	1650	sq_ft	1443
price	276500	price	280000
Rent_Ratio	9.24	Rent_Ratio	7.61
Mean_Income	59089	Mean_Income	97084
Inventory	25	Inventory	152
garages	0	garages	0
type	1	type	1
cluster	0	cluster	0
cluster1	0	cluster1	0
Classification Score	1	Classification Score	1
psq_ratio	167.576	psq_ratio	194.04
CMA_Ext_Price	271744	CMA_Ext_Price	237653

Figure 19 Final Display of Recommended Properties

## CONCLUSIONS

The Extended CMA algorithm generates a set of properties beyond nearby areas. An application developed using the Extended CMA algorithm can address the need of investors beyond a small geographical area. An application developed using Extended CMA algorithm can eliminate the dependency to multiple realtors to find properties in a large area. An application developed using Extended CMA algorithm can automate real estate search in terms of geographical area, number of properties etc. The algorithm considers a wide range of features and synthetic features. Extended CMA can provide a far greater number of properties to the user than the regular CMA and existing real estate portal searches.

## REFERENCES

- [1] A. Barone, "Comparative Market Analysis," Investopedia, 18-Nov-2019. [Online]. Available: <https://www.investopedia.com/terms/c/comparative-market-analysis.asp>. [Accessed: 20-Nov-2019].
- [2] D., Banerjee & S., Dutta (2017). Predicting the housing price direction using machine learning techniques. 2017 IEEE International Conference on Power, Control, Signals and Instrumentation Engineering (ICPCSI). doi:10.1109/icpcsi.2017.8392275.
- [3] "Discover a place you'll love to live," Trulia Real Estate Search. [Online]. Available: <https://www.trulia.com/>. [Accessed: 22-Nov-2019].
- [4] Find Real Estate, Homes for Sale, Apartments & Houses for Rent: realtor.com®," Find Real Estate, Homes for Sale, Apartments & Houses for Rent | realtor.com®. [Online]. Available: <https://www.realtor.com/>. [Accessed: 22-Nov-2019].

- [5] H., Shi, (2009). Determination of Real Estate Price Based on Principal Component Analysis and Artificial Neural Networks. *2009\_Second International Conference on Intelligent Computation Technology and Automation*: 314-317.
- [6] H, Xiaolong and Z,Ming, "Applied research on real estate price prediction by the neural network," *2010 The 2nd Conference on Environmental Science and Information Application Technology*, Wuhan, 2010, pp. 384-386.
- [7] J. Kimmons, "The Real Estate CMA," *The Balance Small Business*, 08-May-2019. [Online]. Available: <https://www.thebalancesmb.com/comparative-market-analysis-in-real-estate-2866366>. [Accessed: 20-Nov-2019].
- [8] K. Treece , "Comparative Market Analysis: Ultimate Guide to a CMA in Real Estate," *Fit Small Business*, 22-Feb-2019. [Online]. Available: <https://fitsmallbusiness.com/comparative-market-analysis/>. [Accessed: 18-Nov-2019].
- [9] M. Valdenegro, R. Verma, and A. K. Jayaraman, "Keras - Plot training, validation and test set accuracy," *Stack Overflow*, 01-Feb-1967. [Online]. Available: <https://stackoverflow.com/questions/41908379/keras-plot-training-validation-and-test-set-accuracy>. [Accessed: 23-Jan-2020].
- [10] O. Prakash, "Scikit K-means clustering performance measure," *Stack Overflow*, 01-Jun-1967. [Online]. Available: <https://stackoverflow.com/questions/43784903/scikit-k-means-clustering-performance-measure>. [Accessed: 02-Dec-2019].
- [11] P. A., Viktorovich, P. V., Aleksandrovich, K. I., Leopoldovich, & P. I.,Vasilevna (2018). Predicting Sales Prices of the Houses Using Regression Methods of Machine Learning. 2018 3rd Russian-Pacific Conference on Computer Technology and Applications (RPC). doi:10.1109/rpc.2018.8482191
- [12]"Property Characteristics," *ATTOM Data Solutions*. [Online]. Available: <https://www.attomdata.com/data/property-data/property-characteristics/>. [Accessed: 18-Nov-2019].
- [13] S., Lu, Z., Li, Z., Qin, X., Yang & R. S. ,Goh (2017). A hybrid regression technique for house prices prediction. 2017 IEEE International Conference on Industrial Engineering and Engineering Management (IEEM). doi:10.1109/ieem.2017.8289904USA: Abbrev. of Publisher, year, ch. x, sec. x, pp. xxx-xxx.
- [14] S. S. Nazrul, "Clustering Based Unsupervised Learning," *Medium*, 15-May-2018. [Online]. Available: <https://towardsdatascience.com/clustering-based-unsupervised-learning-8d705298ae51>. [Accessed: 02-Dec-2019].
- [15] S. Zhou, L. Cao and Y. Li, "Evaluation model for Real Estate Investment Environment Based on SVM," *2008 International Workshop on Modelling, Simulation and Optimization*, Hong Kong, 2008, pp. 192-195
- [16] Visualization - Keras Documentation. [Online]. Available: <https://keras.io/visualization/>. [Accessed: 03-Dec-2019].
- [17] Zillow. [Online]. Available: <http://www.zillow.com/>. [Accessed: 22-Nov-2019].

## **ADVANTAGES OF EXPERIENTIAL LEARNING FOR MBA STUDENTS**

Dr. Mohammad Ahmadi - Gary W. Rollins College of Business, The University of Tennessee  
Chattanooga, Chattanooga, TN 37403

Dr. PARTHASARATI DILEEPAN - Gary W. Rollins College of Business, The University of  
Tennessee Chattanooga, Chattanooga, TN 37403

Dr. Marilyn Helms - Dean School of Business, Dalton State College 650 College Drive, Dalton,  
GA 30720

### **Abstract**

This paper describes a student-centered experiential learning component of the MBA level quantitative decision analysis course and benefits from this high impact practice as viewed by students and faculty. In this student-centered experiential learning component, teams work on research projects in which they apply theoretical model-building knowledge to actual 'real-world' business problems. Following completion, a survey of students' opinions regarding the experiential learning component of the course showed positive results. Most students were "very satisfied" to "satisfied". Steps for implementation are included following the discussion along with areas for future research.



## ADVANTAGES OF EXPERIENTIAL LEARNING FOR MBA STUDENTS

### INTRODUCTION

MBA programs began around the turn of the twentieth century with the broad participation of current and retired corporate managers of the time, so much so, Friga et al. (2003) refer to this period as the "Corporate-Based Era." Then, in the 1950's, with the significant financial support of the Ford Foundation, attempts were made to move MBA programs from vocational focus to a more academically rigorous focus based on scientific research, one that would emphasize educating students for careers in business rather than basic techniques necessary for an entry-level job (Schlossman et al., 1998). One of the outcomes of this change was the increasing emphasis on basic management research (Friga et al., 2003). This era is referred to as "Faculty-Based Era." Concerns emerged that these changes led to management education being overly scientific and lacking relevance to the 'real world' of business (Birnik & Billsberry, 2008). The scientific research approach, they argue, clearly emphasizes analysis and quantification, rather than essential managerial qualities including judgement, interpretation, reflection, and personal values. The remedy they proposed, in part, is that business schools should be characterized by their applied nature.

Bennis and O'Toole (2005) argue that the 'scientific model' is predicated on the assumption that business is an academic discipline when, in fact, it is a professional discipline, akin to medicine and law. In their view, curricular reforms will work only when the scientific model is replaced by a model supporting business as a profession. To gain relevance, Bennis and O'Toole (2005) emphasize, business school faculties must rediscover the practice of business and serve the business community by educating practitioners and generating knowledge they can use.

Similarly, Upadhyay and Paul (2019) agree academic institutions must engage students and prepare them for industry needs.

Are we now back full circle to a corporate-based era in which MBA programs resemble vocational training? The answer may lie in synthesizing both philosophies into one that transcends the apparent dichotomy between them. Friga et al. (2003) observe that knowledge creation takes place not only in ivory towers, but also in corporate boardrooms. So, they suggest moving to the "Student-Based Era", one that assimilates knowledge created by corporations and other organizations and distributes this knowledge in a manner that is student-centered. This supports Garnjost and Lawter (2019) who found that employers value problem solving, critical thinking, and self-directed learning and that students perceive better learning and higher satisfaction from project-based learning.

In this paper, we describe a student-centered experiential learning component within the MBA-level quantitative decision analysis course and the benefits, as viewed by students, from this high impact practice. In this student-centered experiential learning component, research projects apply theoretical model-building knowledge to actual 'real-world' business problems.

### **LITERATURE REVIEW**

A recurring concern underlying the debate described above is how to make MBA programs relevant to all stakeholders. Employers, a key stakeholder, rank communication skills as most important, followed by teamwork, technical skills, leadership skills, and managerial skills (GMAC, 2017). Neelankavil (1994) presented a survey of 108 human resource directors (HRD) of *Fortune* 1,000 companies in which they complain most MBA graduates are arrogant and lack communication skills. The survey also found, in the opinion of the HRD's, many MBA programs focus on technical skills to the exclusion of communication skills. To improve the

communication skills of MBA graduates, Neelankavil (1994) argues that the number of written assignments and oral presentations must be increased in most classes at the graduate level and be evaluated both content and writing style.

Yousef (2017) studied the impact of three factors on academic performance, namely, teaching style, English language communication, and assessment methods. With his United Arab Emirates University students, he found English language skills had the most predictive value, accounting for about ten percent of the variance of the performance measures, yet there are numerous other factors that could affect learning. Minhas (2017) gave his students an opportunity to select projects based on their heritage and communities. The study concluded that communications improved, and experiential learning had a major effect on motivation and personal development.

The academic literature is filled with interesting and innovative ideas that address concerns of MBA assignment relevance. Hart et al. (2005) presents an experiential, team project in which student teams with non-profit organizations to analyze communication effectiveness and offer suggestions for improvement. They describe a project where student teams gathered quantitative and qualitative data using interviews, surveys, critical incident analysis, network analysis, participant observation, document review, and focus groups. The data was then analyzed with respect to where, what, how, and when employees were receiving and sending information as well as the quality of the information transmitted. This process revealed areas of success along with areas for improvement. Once all data was analyzed and interpreted, the student teams prepared a written report. Hart et al. (2005) reported that participating students acknowledged their increased skills in the areas of communication, teamwork, interviewing, research and analysis from the project.

Williams et al. (2015) presents how written communications were integrated in a Management Science course. In their approach, students were required to articulate ways an organization can use a mathematical programming model to aid decision-making. The students were expected to identify business decisions, write a statement of the business objective, describe constraints, and prepare potential follow-up questions for sensitivity analysis in a final exam essay. The final exam also included essay questions requiring students to describe the use of management science concepts and analysis to solve a problem in a practical scenario. The authors found student performance on the essay component had a positive impact if the semester included extra practice essay quizzes, detailed feedback on the essay quizzes, and class discussion when the essay quizzes were returned in class.

Another effective approach to bring 'real-world' relevance to MBA courses is to incorporate a comprehensive project. Fish (2007) presents such a comprehensive project experience in an Operations Management class. Their project required students to develop a strategic, tactical, and operational plan for a single product with at least five components and at least three bill-of-material levels. Included in the project were specific operations management topics including process strategy, demand management, inventory management, and quality management. The project addressed business communication skills through the written report and team presentation. The end-of-semester survey found over 94% student approval, indicating the assignment to be a successful way to learn operations management application concepts.

D'Souza and Maheshwari (2010) examined the factors influencing student performance in an introductory Management Science course over a two-year period. Of the 333 students in the course, 297 students finished the course with grades of "A". They considered a range of factors under six different categories, namely, student demographics, course structure,

instructional methods, student motivation and effort, student aptitude and application, and student preparation. Using step-wise multiple regression methodology, they found four independent variables; current class grade point average; average homework score; course utilization ratio; and completion of pre-calculus prerequisite to be significant factors predicted of overall student performance in the course.

Piercy et al. (2012) examined the effectiveness of experiential learning on Operations Management course. They studied two module configurations, one was small with 20 students per class and the other large with 90 students per class. The experiential learning component was an operations game, based on a business simulation developed at the Lean Enterprise Research Centre at Cardiff Business School in the late 1990s. They surveyed students from both modules at the conclusion on the quality of the exercise design, satisfaction, value, and preference of teaching methods. The authors found students from both modules expressed a preference for experiential learning as well as high levels of satisfaction with the simulation game.

Robinson et al. (2003) describe a failed attempt and a second successful one in which they redesigned their MBA Operations Research/Management Science (OR/MS) course. The failed first attempt, which received the lowest student ratings, involved moving away from lectures and relying on students reading the text. In this approach, the classes began with the students working on a group case study with minimal formal teaching beforehand. Then, a class discussion followed their solutions. The expectation of this approach was that students learn to use OR/MS techniques and when to apply them in a business context. Their second attempt redesigning the course was also built around the case analysis approach. They began the classes with “mini-lectures” and provided guidance on ways to approach the cases. More lectures were conducted mid-way into the case analysis and student groups presented their preliminary

findings. At the end of the case studies, the case solutions were provided and discussed, including a summary of key learning points. Another feature Robinson et al. (2003) added was optional workshops near the beginning of the module and question-and-answer sessions at the end of classes for students having difficulty with mathematics, though, they note, few students took advantage of these optional sessions. Student scores were higher for interest level, relevance and overall value in the second attempt. In a voting of the best module at the core level, the authors report, the OR/MS module received the second highest number of votes.

Thus, the academic peer-reviewed literature contains much support for using experiential learning in online education. Watanabe (2017) demonstrated that experiential learning can be useful when students are placed in multi-cultural global virtual teams. The study suggests that the process experienced by virtual student teams has similarities with team formation stages in actual organizational settings.

## **METHODOLOGY**

The MBA is a professional, graduate degree that does not generally include a major. Furthermore, MBA programs intend to prepare students for the working world and not that of academic research. Thus, a majority of universities offering an MBA degree do not require writing a thesis for completing the program. However, learning the research process and conducting research is of value to all graduate students in their future work. In this study, we describe a student-centered experiential learning component in the MBA level quantitative decision analysis course and the benefits as viewed by students. Our goal is to show such experiential learning components provide opportunities for students to integrate knowledge from

the classroom with the knowledge created by corporations and other organizations and solve actual 'real-world' business problems.

The University of Tennessee at Chattanooga (UTC) is an urban university located in Chattanooga Tennessee. Enrollment at the University of Tennessee at Chattanooga (UTC) is over 11,500 students. UTC's Gary W. Rollins College of Business is a SACS-COC and AACSB accredited school with 2,167 undergraduates and 320 graduate students. The college offers undergraduate degrees in accounting, finance, entrepreneurship, management, analytics, human resources, economics, and marketing. At the graduate level, the Master of Business Administration (MBA) and Master of Accountancy (MACC) degrees are offered. The quantitative decision analysis course (MGT 5835) is a required course for students who do not have a background in data analytics.

The course covers probability, decision analysis, regression and correlation, forecasting, inventory, optimization methods, project management, quality control, and simulation. Upon completion of the course, students have enough knowledge of analytics to collect, analyze data, and use their analytic knowledge in making better decisions.

In addition to introducing students to analytics, other course objectives are to:

- Analyze and convert data to useful information
- Use computer technologies for problem solving
- Use information to enhance critical thinking
- Apply knowledge to a team research project
- Enhance ability to work in a group

Students' performances were evaluated by the grading of the five components of the course. These components and their associated values are shown below.

<b>Items</b>	<b>Points</b>
First Examination:	100
Final Examination:	100
Weekly Assessments	100
Research Project	45
Peer Evaluation	5
<b>Total points</b>	<b>350</b>

#### Grading Scale

315 - 350 A	280 - 314 B	245 - 279 C	210 - 244 D	Below 210 F
----------------	----------------	----------------	----------------	----------------

Most of the students are enrolled part time in the MBA program and work full time at various companies located in Chattanooga, Tennessee and the surrounding metropolitan areas. All graduate courses are offered in the evenings or online.

Students are required to complete a research project as part of the course. The project is undertaken by groups of students, not exceeding three students per group. Each team chooses their own research topic approved by the professor, or they select a topic from the professor's provided suggestions. By the third week of the semester, a short two-page, double-spaced research proposal is submitted. Students are asked to be brief but clear in the explanation of their objectives. After the proposals are approved, students are to lay the foundation for their research project. Students work with their group members and submit the result of their research project in a formal written paper at the end of the 16-week semester. Students are instructed their final reports should contain the following items:



<b>Content</b>	<b>Description</b>
Abstract	An abstract is a summary of the paper with enough information about the selected topic and the findings presented in the completed paper. The abstract is limited to approximately 250 words.
Introduction	A brief overview of the research project.
Literature Review	A report of previous research that has been done on the selected topic. The literature review should be current and must include a complete bibliography with at least 10 separate sources from academic and nonacademic journals.
Methodology	Explanation of the project, the methodology, and hypotheses in detail.
Data and Results	Explanation of how the data was gathered, what data were collected, and what type of procedures were used for the analysis of the data
Conclusion and Implications	Presentation of the results, conclusions and the implications of such conclusions.

The purpose of this major assignment is to learn to conduct research and to write a business report summarizing their findings. In the process, students learn to convert “data” into “information.” They are provided with examples at the beginning of the semester. Their work is graded based on correctness, organization, presentation, completeness, and soundness of analyses and relative to the work of the other teams.

Students are informed that the main component of the grading is with the content and soundness of projects. However, they are also apprised to be concerned with the grammatical aspect of their paper. Typos, misspelled words, run-on or incomplete sentences and other errors result in reduced grades. Part of the students’ grades on their research paper is determined by their group members assessments of their contributions. Thus, every group member may receive a different grade on the research project.

## Example Projects

Students selected a variety of topics. A brief description of a sample of the projects are presented below.

<b>Team Project Example</b>
<p>• <i>The Amazon Effect: Impact on the United States Economy and Jobs</i>            This Study explored the effect Amazon is having on the economy. Consumers enjoy Amazon for the low prices and convenience, but what is the long-term effect of Amazon's dominance?</p>
<p>• <i>Distracted Driving and Fatalities in the United States: An analysis of various distracted driving categories</i>            This study focused on the causes of distracted driving in the United States and more specifically the correlation between distracted driving and the use of electronic devices while in the vehicle by the drivers involved in these fatal accidents. Data from the NHTSA/CrashStats for traffic fatalities attributed to distracted driving were used to preform analyses with comparisons between various distracted driving categories.</p>
<p>• <i>Female Executives and Performance</i>            This study compared performance of companies with women in the C-suite versus those without female representation. By evaluating stock performance and return before and after women were involved with the company, sales of the company, and any other indicators of performance, the results presented a more complete picture of female's contribution to the success of these top companies.</p>

After the course completion, a survey of student experience and satisfaction was administered and is included in Table 1.

**TABLE 1: RESEARCH PROJECT EXPERIENCE SURVEY**

1. The research project strengthened my understanding of the concepts covered in class.
2. In the future, the research project should remain as a part of the course learning experience.
3. My ability to analyze data using quantitative models has improved because of completing the research project.
4. My ability to interpret the results of quantitative models used for data analysis has improved because of completing the research project.
5. My ability to synthesize and present the results of quantitative models in the form of a research report has improved because of completing the research project.
6. I can use the information I gained from completing the research project at my work.
7. The grading weight assigned to the research project was proportional to the time and effort required to complete it.
8. Overall, how satisfied were you with your experience with the research project?

**Open-ended Questions**

9. State everything you liked about the research project.
10. State everything that you disliked about the research project.

The following choices given to students for questions 1 – 8 as follows.

- a. Strongly disagree
- b. Disagree
- c. Neutral
- d. Agree
- e. Strongly agree

Table 2 shows a summary of the responses of the eight questions to the survey.

**Table 2: Summary of Survey Responses**

Answer Choices	Q1	Q2	Q3	Q4	Q5	Q6	Q7	Q8	Average
Strongly disagree	6%	3%	3%	3%	3%	6%	6%	0%	4%
Disagree	6%	11%	11%	9%	9%	14%	17%	9%	11%
Neutral	20%	23%	23%	20%	23%	34%	14%	29%	23%
Agree	43%	34%	46%	57%	43%	31%	51%	34%	43%
Strongly agree	26%	29%	17%	11%	23%	14%	9%	29%	20%
<b>Agree/Strongly agree</b>	<b>69%</b>	<b>63%</b>	<b>63%</b>	<b>69%</b>	<b>66%</b>	<b>46%</b>	<b>60%</b>	<b>63%</b>	<b>62%</b>

The survey questions are categorized into three groups. Question numbers 1, 3, 4, and 5 relate to “concept comprehension”. Questions 2, 7, and 8 relate to “overall satisfaction” of the experiential learning activity. Question 6 relates to whether the knowledge gained can be used in the student's current work environment. The survey results summarized by question groups are presented in Table 3.

**Table 3: Summary of Survey Responses by Groups**

Answer Choices	Group 1 (Concept Completeness)	Group 2 (Overall Satisfaction)	Group 3 (Usefulness of Knowledge)
Strongly disagree	4%	3%	6%
Disagree	9%	12%	14%
Neutral	21%	22%	34%
Agree	47%	40%	31%
Strongly agree	19%	22%	14%
<b>Agree/Strongly agree</b>	<b>66%</b>	<b>62%</b>	<b>46%</b>

(Group 1 = Q1, Q3, Q4, and Q5; Group 2 = Q2, Q7, and Q8, Group 3 = Q6)

The results, as shown in Table 3, indicate that for Concept Completeness, questions, 66% of the students responded the experiential learning project helped them understand, comprehend, synthesize and present the topics covered in the course. The score of 62% for Overall

Satisfaction questions indicates a high level of overall satisfaction and a desire for the experiential learning project to be continued in future classes. The result of Usefulness of Knowledge shows that only 46% of students “strongly agreed” or “agreed” with this question that knowledge gained by the experiential learning project could be immediately used in their work. The lower score may be due to the present employment level of the students, or the relatively low adoption of advanced numerical techniques in the student's work place.

The last two questions (9 and 10) of the survey instrument solicited open-ended responses from the students. The positive and the negative responses from the students are shown below grouped into categories.

### **Positive Learning Outcomes**

When asked about what they liked from the research project, students enjoyed the real-world applications as shown in comments including:

- *Real world use of our skill and knowledge learned in our class.*
- *The research project allowed us to apply the concepts we learned in class to real world examples.*
- *Excellent application to real world.*
- *Great opportunity to apply theory to practice*

The assignment also impacted career choices as seen in these comments:

- *The topic my team chose allowed all three of us to explore different options for our future and led each of us to three very different paths after the class was over. One of the three left the MBA program, one joined the program full time, and one continued working full-time and attending the program part time*
- *The comparative model our team created helped to influence the three of us in three very different ways. One left the program, one quit their job and committed full time to the program, the third continued with the MBA program, but is also pursuing additional certification.*
- *The project was difficult to find specific data that we were looking (MBA grad salary for our college in the local area, but it challenged us to use national or state-wide data, find comparable schools/populations/salaries and extrapolate what our data would be.*

*It was rewarding working with a small dedicated team. The model is extremely useful for any subject given sufficient comparable data.*

Students also learned new analytical techniques as evidenced by the

following comments:

- *I enjoy data analysis, but this project gave me the opportunity to try working with a predictive model I have never used. Because of that, I feel I learned a lot and gained applicable knowledge. I also got to work within a topic that interested me, making the project interesting. For me, it is always easier to learn analytical concepts when I am able to apply them to a real/relevant issue, which this project allowed,” and “Hands-on real experience using data.*

Teamwork was also noted in the following topics:

- *Collaborating with classmates as one will likely do in a work setting, working together to achieve a common goal and the flexibility for us to choose our own topic to research was very positive*
- *provides an opportunity for teamwork -provides an opportunity for research*
- *I enjoyed how well our team collaborated. As two people took different perspectives it made for a very interesting dialogue within the research paper itself*

Students also appreciated the ability to hone their research skills as shown in these

comments:

- *Establishing a project that last more than a few weeks creates a cumulative effort of more than one assessment week to week. I found that the work required was extensive, but also good to work on an effort that required planning for more than a week or two.*
- *The open subject matter makes it easier to dedicate time to the effort. I found it useful to hone the skills to research and create a project document*
- *I liked being able to relate different sections of material we worked on throughout the semester into the project. It made the topics more tangible, and in my opinion, made them a little more understandable when we were able to compute the information from data we found. I liked finding different pieces of data and then deciding with the group how we were going to interpret the data into a useful part of the project*
- *It provided a broader perspective and enabled me to have a better understanding*

- *I believe it is a good exercise in finding a topic of interest and applying newly formed skills*
- *The assessments were great! They covered a broad range of real-world purposes for using the concepts in the course*
- *the flexibility to research and analyze data from whatever source needed while using our professor as a support structure.*

As was predicted, learning was also noted in these examples:

- *I learned a lot from my research topic. Not only for myself personally but for the class as well. I also think I learned a lot more about my team members throughout the semester due to the research project and that was very important as networking is key in today's world, thank you!*

### **Areas for Improvement**

When the MBA students were asked for comments and suggestions for improvement, the categories grouped into key areas of prefer a presentation, link to campus, community or work, clearer expectations and examples, dissatisfaction with group projects in general, eliminate the project, and implementation changes.

**Prefer a Presentation.** Several students would prefer a presentation as noted in these two comments:

- *I strongly disagree with the ideas of papers in general. I believe in presentations with Q&A segments to help foster a culture of learning the material on an in-depth level*
- *Additionally, having to present the project (short ten minutes presentation) would also be valuable for both students and customers. Thanks!'*

**Link to Campus, Community or Work.** Students noted that projects related to their work, the community or the campus might be preferable and should be recommended. In addition, this could slant the project as a service-learning opportunity for the campus.

The comments included:

- *I think that the research project should be tied to a need somewhere else at the college the surrounding community. Doing a research project for say the engineering dept, athletics, the nursing program, or a nearby small business would give students an actual customer for their project, and be able to see how their project impacts the campus community in the real world*
- *One idea would be to use this class and the research project to assist other areas of the school. Like a request from the environmental science program that a team of students could work on as a project. Or a request from the school of nursing, athletics, ROTC, etc. These "customers" could provide some of the data, that a team of students could utilize as a research project. The project could then be presented back to the "customer". Not only would this build experience with QA but would allow MBA students an opportunity to interact with a customer, maintain timelines, deliver a finished product, and give a business presentation at the end, while also helping other areas of the campus improve and make smarter, data driven decisions. The projects could also be highlighted in campus newsletter to show the value of QA and how the MBA program is positively impacting the campus*
- *I thought the group effort and finalization was very good and then turning it on safe assign was really good vs printing it,' and 'Suggest students to undertake work related efforts so as to really understand process and applications.*

**Clearer Expectations and Examples.** Students always appear to need structure and more directions as noted by the following comments:

- *My understanding of the expectations for the project was not always clear. However, I do feel I came to a good understanding, and I think we always had the opportunity to ask questions if we didn't understand something. It would be nice to know of opportunities to present the research or take it further if we were interested*
- *A bit more guidance from the professor in developing the hypothesis*
- *When looking at the course content, I just felt like the research project was an afterthought. I would have to say that the project was far less essential to the learning experience than all of the other coursework assigned*
- *The lack of specific formats made it hard for me to know where to start. What format what guidelines should be followed? You answered these questions, but I was still intimidated with how broad my options were. Having been out of the academic setting for years this project was larger than I felt ready for at the time. Telling student about the project on the first day when going over the syllabus and*



*remind them 2-3 weeks in might help. Something like "expect a good project to take 40-50 hours or more to complete.*

- *The three good examples helped me, but also providing examples of what not to do would have been beneficial. I personally would have started alone on week 2 or 3 had I know my partner was not going to answer emails and collaborate. I realize grading more papers requires more time. But had we started earlier I would have known sooner I was going to make the project effort alone sooner, thus making it easier to allocate the time and effort to do a good job. I did learn much in the class and the project.*

**Dissatisfaction with Group Projects in General.** As expected from working MBA students with time and family pressures, a few comments included the dissatisfaction with group or team work in general as shown in these comments:

- *I never like group research projects very much, mostly because I feel that I would be able to do a better job and have a more seamless paper if I worked on it alone. However, I do understand the real-world use of working in a group. If the project continues as one for a group, I would perhaps suggest having the teams pick a topic earlier in the semester to work on more gradually. Best case scenario, the teams could, for instance, run a regression analysis on data they found that relates to their research topic in the same week that they learned about it. The groups might still wait until later in the semester to get started, but they could have the option to work on it as they are learning the information*
- *make this an individual project rather than a team project. One person inevitably does all the work,' and 'I suspect you will receive negative comments about "group work" which is tedious. Some students just don't care and that makes it difficult for those that do. I am wondering if two to three "case studies" done independently wouldn't work better while keeping the assessments as group work. Either way, case or paper, I think it is important to be able to apply the skills without being led through the work.*

**Eliminate the Project.** Interestingly only one student noted to eliminate the project all together in this comment:

- *I feel that the assignment needs no improvement other than to eliminate it all together because of how rigorous the course is.*

**Implementation Changes.** Students were vocal about ways to improve the project's implementation as shown in these ideas:

- *Encourage students to start background search early. Provide some examples of prior students work.*
- *great project and effort*
- *I thought that splitting the research paper up into bite sized chunks, each worth a small part of the grade*
- *Have it be a part of the class, but the only criteria for grading would be that you had something*
- *Other teams would review your work and make some comments. I also think that the paper should be the equal of a test in terms of point*
- *Provide more structure on what the project should be. provide more detail on what a professional report should look like.*
- *provide class time for group work, perhaps a day where a proposal is due and must be discussed face to face with faculty and include oral presentations*
- *dedicate some time in class halfway into the semester to discuss research projects.'*

### **DISCUSSION AND CONCLUSIONS**

Generally, MBA programs do not require students to write a thesis overall and few require class research paper. Hence, students lack learning and appreciation of the complete research process. The purpose of this study was to analyze the benefits, as viewed by students, of adding a required student-centered experiential learning component to the MBA-level quantitative decision analysis course. Students viewed this addition as a very valuable learning component and indicated that such an experiential learning component provides opportunities to integrate knowledge from the classroom with the knowledge created by corporations and other organizations and solve actual 'real-world' business problems.

### **AREAS FOR FUTURE RESEARCH**

In this paper, the focus was entirely on the face-to-face (FTF) delivery of the quantitative decision-making class. Differences are in methods of delivery of material, the environment, students, and other factors should be considered in future research. One major possible research

will be to conduct the same study with the online classes. As suggested by one student, it might be beneficial to add the dimension of having students present their research project and results in class and this would also extend the findings. The sample size for this study was somewhat small, and larger sample sizes as well as studying longitudinal data would enhance the study as would comparing similar classes at multiple institutions across a global sample. Another area the authors are considering undertaking is requiring a Meta-Analysis research by which students will become familiar with many selected studies and arrive at their own conclusions. Findings from this analysis should be another area for future research.

**REFERENCES**

- Bennis, Warren G; and O'Toole, James (2005). "How Business Schools Lost Their Way", *Harvard Business Review*, Vol.83, No. 5, pp. 96 – 104.
- Birnik, Andreas; and Billsberry, Jon (2008). Reorienting the Business School Agenda: The Case for Relevance, Rigor, and Righteousness, *Journal of Business Ethics*, Vol. 2, pp. 985 - 999.
- D'Souza, Kelwyn A.; and Maheshwari, Sharad K. (2010). "Factors Influencing Student Performance in the Introductory Management Science Course", *Academy of Educational Leadership Journal*, Vol. 14, No. 3, pp. 99 – 119.
- Fish, Lynn (2007). "Graduate Student Project: Operations Management Product Plan", *Journal of Education for Business*, Vol. 83, Iss. 2, pp. 59 – 71.
- Friga, P. N.; Bettis, R. A.; and Sullivan, R. S. (2003). "Changes in graduate management education and new business school strategies for the 21st century", *Academy of Management Learning and Education*, Vol. 2, No. 3, pp. 233 - 249.
- GMAC 2017 Corporate Recruiters Survey Report, Employment Outlook, Research, Global, 2017, Corporate Recruiters Survey, Survey Report, R. Estrada-Worthington, Graduate Management Admission Council, <https://www.gmac.com/market-intelligence-and-research/research-library/employment-outlook/2017-corporate-recruiters-survey-report.aspx>
- Garnjost, P., & Lawter, L. (2019). Undergraduates' satisfaction and perceptions of learning outcomes across teacher-and learner-focused pedagogies. *The International Journal of Management Education*, 17(2), 267-275.
- Hart, Claudia; Vroman, Margo; and Stulz, Karin (2005). "Experiential, Collaborative and Team Projects: Communication Audits in The MBA Communication Course" *American Journal of Business Education*, Vol. 8, No. 4, pp. 288 – 306.
- Magnier-Watanabe, Remy; Yoshiaki Watanabe, Olivier Aba, Harald Herrig (2017). "Global virtual teams' education: experiential learning in the classroom", *On the Horizon*, Vol. 25 Issue: 4, pp. 267-285.
- Minhas, Wasif and Jo Perret, (2017). "A UAE case study: experiential learning through effective educational partnerships", *Journal of Applied Research in Higher Education*, Vol. 9 Issue: 2, pp. 304-312.
- Neelankavil, James P (1994). Corporate America's quest for an ideal MBA, *The Journal of Management Development*, Vol. 13, No. 5, pp. 38 – 52.
- Piercy, Niall; Brandon-Jones, Alistair; Brandon-Jones, Emma; and Campbell, Colin (2012), "Examining the effectiveness of experiential teaching methods in small and large OM modules", *International Journal of Operations & Production Management*, Vol. 32, No. 12, pp. 1473-1492.

Robinson, Stewart; Meadows, Maureen; Mingers, John; O'Brien, Frances A; Shale, Estelle A.; and Stray, Stephanie (2003). "Teaching OR/MS to MBAs at Warwick Business School: A turnaround story" *Interfaces*, Vol. 33, No. 2, pp. 67 – 76.

Schlossman, Steven; Sedlak, Michael; Wechsler, Harold (1998). The "new look": The Ford Foundation and the revolution in business education, *Selections*, Vol. 14, No. 3, pp. 8 - 28.

Upadhyay, P., & Paul, M. (2019). The linkage between knowledge management practices and Organization Based Projects for better learning outcome: A Conceptual Framework. *International Journal of Educational Management*, 33(1), 166-178.

Williams, Julie Ann Stuart; Stanny, Claudia J.; Reid, Randall; Hill, Christopher; Rankin, Maxwell; and Rosa, Katie Martin (2015). "Assessment of Essays in a Management Science Course", *The Coastal Business Journal*, Vol. 14, No. 1, pp. 1 – 12.

Yousef, Darwish Abdulrahman (2017). "Factors influencing academic performance in quantitative courses among undergraduate business students of a public higher education institution", *Journal of International Education in Business*, Vol. 10, No. 1, pp. 12 – 30.

## **AN INITIAL EMPIRICAL INVESTIGATION OF THE USE OF SODA I AND II**

Patrick Hester, Department of Management and Accountancy, University of North Carolina Asheville, 1 University Heights, Asheville, NC 28804, 828-251-6842, phester@unca.edu

### **ABSTRACT**

Problem structuring methods are espoused by many researchers and practitioners as being useful in the context of framing and understanding wicked problems. The utility of these methods is often demonstrated anecdotally through stakeholder surveys and interviews. However, there is a lack of clear, empirical demonstration of the utility of these methods as contrasted with problem solution efforts not using such methods. As an initial experiment, a group of undergraduate students was exposed to two problem structuring methods, Strategic Option Development and Analysis (SODA) I [5] and SODA II [6]. These methods were utilized on a fictitious problem and confidence in student recommendations was analyzed. Further, SODA I and SODA II were assessed for their relative utility in understanding complex problems. This second set of experiments was repeated using two separate example problems to test robustness of results. A set of hypothesis tests was used to analyze the results of these experiments. Initial results indicate some significant findings supporting the use of problem structuring methods and a need for further research.

### **Introduction**

Problem structuring methods (PSMs) are espoused by many researchers and practitioners as being useful in the context of framing and understanding wicked problems [1,2,8,9,16,17]. The utility of these methods is often demonstrated anecdotally through stakeholder surveys and interviews, but there is a lack of clear, empirical demonstration of the use of these methods as contrasted with problem solution efforts in the absence of such methods. This paper begins to bridge this gap by conducting an initial empirical investigation into the utility of problem structuring methods, specifically Strategic Option Development and Analysis (SODA) I [5] and SODA II [6]. These methods were utilized by a group of undergraduate students who were exposed to a fictitious problem. First, confidence in student recommendations was analyzed. Further, SODA I and SODA II were assessed for their relative utility in addressing complex problems. This second set of experiments was repeated using two separate example problems to test the robustness of results. A set of hypothesis tests was used to analyze the results of these experiments. Initial results indicate some significant findings and a need for further research.

This paper begins with a brief discussion of SODA and the underlying theory behind it. This is followed by a discussion of the experimental design undertaken for this analysis. I then present results, and finally conclusions of the study and potential areas for future research are provided.

## **Strategic Options Development and Analysis**

Strategic Options Development and Analysis (SODA) belongs to a class of methods known as problem structuring methods. Problem structuring methods are part of what is termed soft OR (operations research), as contrasted to traditional hard OR. “The word hard refers to the use of mathematical and quantitative techniques...The soft in soft OR simply refers to the orientation of the approach as qualitative or interpretative rather than quantitative, as is the focus of hard OR... In very general terms, therefore, soft OR methods are those that structure a problem, as opposed to hard OR that seeks to solve it.” [10, pp. 2-4]. Techniques such as optimization, simulation, and decision analysis are typically considered hard OR techniques, whereas soft OR includes techniques such as Soft Systems Methodology and Strategic Options Development and Analysis (SODA), which is the focus of this paper. It is important to note that soft OR techniques, if deployed correctly, should be deployed in conjunction with hard OR techniques, and not in opposition to them. “Problem structuring can be defined as the process of arriving at a sufficient understanding of a particular problem so as to proceed to some sort of formal modelling” [15, p. 1063].

Strategic Options Development and Analysis (SODA) is a specific problem structuring technique based on the theoretical basis of cognitive mapping. Cognitive maps can be thought of as sophisticated influence diagrams. They were pioneered in the work of Robert Axelrod [3] to understand political conflict, but they have been deployed in a number of science, engineering, and management fields since [e.g., 9,13]. The idea of cognitive maps is to develop a shared understanding and appreciation of a complex problem. As such, they are typically used when there is confusion or debate surrounding the formulation of a particular problem.

Cognitive maps are composed of two fundamental elements—concepts (nodes) and arrows (arcs). Concepts are ideas or concerns expressed by an individual or a group, expressed in one’s own words. They represent the “actors, entities and social, political, economic or abstract concepts that compose the system. Examples of concepts might be Inflation, the actions of an influent Politic, a Revolution, the Wealth of an individual or a nation, the Welfare of population, Road conditions, etc.” [4, p. 8]. Concepts are connected by arrows, which show causal relationships between concepts. The start (or tail) of an arrow is the means to achieving the concept at the end (or head). These connections can be either positive or negative, indicating the direction of causal influence.

Cognitive maps can be used as a standalone technique, or within the Strategic Options and Development and Analysis I or II method. SODA I was introduced by Colin Eden [5] and focuses on individual cognitive maps being merged into a comprehensive map to help groups understand problems. SODA I is good for situations in which individuals may have strongly held opinions, but these opinions need to be blended in order to move forward organizationally. SODA II, introduced by Eden and Ackermann [6], builds cognitive maps collectively as a team. This approach helps with map ownership and member buy-in, but it may lead to issues arising from power dynamics due to the open debate about map structure and content.

Research has shown that confidence affects the decision-making process [11,18]. Further, Kotiadis & Mingers state that problem structuring methods are useful in dealing “with messy, wicked and complex problems that are not amenable to the traditional, largely quantitative, OR techniques” [12, p. 856]. With these elements in mind, it would be useful to know whether or not SODA improves confidence in decision making, and if either SODA I or SODA II is more effective at capturing problem complexity. Neither Eden [5] nor Eden and Ackermann [6] prescribe one approach over the other, and a review of literature finds no comparative study of the efficacy of an intervention using cognitive mapping, as well as the relative efficacy of SODA I and II. This paper aims to contribute to the literature by providing an initial empirical investigation into the use of these methods.

### **Experimental Design**

The goal of this research is to explore two research questions:

1. Does the use of SODA improve decision maker confidence?
2. Is there a difference in the use of SODA I as compared to SODA II in terms of representing complex problems?

To address these research questions, a number of undergraduate students composed of mostly management majors enrolled in a management science course were exposed to SODA methods and asked to use them to investigate complex problems. These experiments were conducted during three separate semesters (Spring 2018, Spring 2019, and Fall 2019), in two sections of the same course each semester.

The first set of experiments was conducted during the Spring 2018 academic semester. To answer the first research question, students were exposed to SODA methods (both in a classroom environment and through prior assigned reading) and provided the following information (hereafter referred to as the John example):

*John is a new graduate from college and one of your best friends. After passing a probationary period at his job, he is asking for your advice on his life situation. He keeps complaining about the stress that he has experienced during the probationary period. He tells you that he will finally have 3 weeks paid time off, which he must use within 6 months. He also has \$10,000 in his savings account.*

Students were then given one of the following pieces of additional information:

- A. John has \$30,000 in student loan debt.
- B. John is planning to get married next year.
- C. John has always wanted to visit Europe and has never been there.

Students were then instructed to form a group consisting of one “A”, “B”, and “C” member and to discuss the information they had and their thoughts about what advice they should give John. Students were asked to determine a) what options John had, b) their suggestion for John, and c) their confidence level in their suggested plan (on a scale of 0-10). Students were then exposed to SODA I and SODA II and the fundamentals of cognitive mapping, and asked to reform their groups and answer the same questions using a cognitive map they



developed as a guide. A comparison of their confidence scores was undertaken and is discussed in the results section.

During the Spring 2019 semester, the second set of experiments was conducted as the John example was again presented to students, however, this time the focus was on determining the relative effects of using SODA I or SODA II. Since I teach two sections of the same course, this was easily accomplished experimentally. In one class section, students were asked to build individual cognitive maps and then form groups and build a collect cognitive map (using SODA I). In the other class section, students were asked to build collective cognitive maps as a team (without first building them individually), utilizing SODA II. A comparison of cognitive map metrics was conducted to determine whether or not either technique produced statistically significant results in terms of basic map metrics. Metrics examined were those reported by the software used for cognitive mapping, Mental Modeler [7]. They included: 1) total concepts, 2) total arrows, 3) density (total number of connections/possible connections), 4) connections per concept (arrows/concepts), and 5) complexity score (# of concepts with only incoming arrows/# of concepts with only outgoing arrows).

During the Fall 2019 semester, a repeat of the second set of experiments was conducted, albeit with a different example. This time, the students were exposed to the Lost at Sea example:

*You are adrift on a private yacht in the South Pacific. As a consequence of a fire of unknown origin, much of the yacht and its contents have been destroyed. The yacht had all navigational equipment destroyed while you and the crew were trying to bring the fire under control. Your best estimate is that you are approximately one thousand miles south/southwest of the nearest land.*

*Below is a list of fifteen items that are intact and undamaged after the fire. In addition to these articles, you have a serviceable rubber life raft with oars large enough to carry yourself, the crew, and all the items listed below. The total contents of all survivors' pockets are a package of cigarettes, several books of matches, and five one-dollar bills.*

*Items:*

*1) Sextant, 2) Small transistor radio, 3) Shaving mirror, 4) Shark repellent, 5) 5 gallon can of water, 6) 20 sq.ft. of opaque plastic, 7) Mosquito netting, 8) 1 case of rations, 9) Maps of the area, 10) Seat cushion (flotation device), 11) 2 gallon can of oil/gas mixture, 12) 1 quart of 160 proof rum, 13) 15 ft. of nylon rope, 14) 2 boxes of chocolate bars, 15) Fishing kit*

As with the previous John example, students in one class section were asked to build individual cognitive maps and then form groups and build a collect cognitive map (using SODA I). In the other class section, students were asked to build collective cognitive maps as a team (without first building them individually), thereby utilizing SODA II. A comparison of cognitive map metrics was conducted to determine whether the techniques produced results that were significantly different from one another in terms of map metrics.

## Results

I first investigated the potential effect on confidence using cognitive mapping techniques to determine whether or not students were more confident in their recommendations after using a cognitive map in an effort to address the first research question posed. This analysis used the following one-tailed hypothesis structure:

$$H_0: \mu_2 = \mu_1 \quad (1)$$

$$H_A: \mu_2 > \mu_1 \quad (2)$$

In this case,  $\mu_2$  is the mean confidence reported by students in their recommendations to John *after* using cognitive mapping, and  $\mu_1$  is the mean confidence reported by students in their recommendations to John *before* using cognitive mapping. This hypothesis is tested for Section 1 of the course, Section 2, and in a combined environment (i.e., both Section 1 and 2 together). Section 1 had 12 participants, and Section 2 had 10 participants. The results of this analysis are shown in Table 1.

**Table 1: Summary Statistics for John Example**

Statistic	Section 1	Section 2	Combined Sections
$\mu_1$	7.63	8.2	7.89
$\sigma_1$	1.26	0.92	1.13
$\mu_2$	8.67	7.6	8.18
$\sigma_2$	1.15	1.90	1.59
n	12	10	22
p-value	.02	0.26	0.41
Significant at $\alpha=0.05$ ?	Yes	No	No

We can conclude that, in Section 1, there was a significant increase in confidence when using cognitive mapping. In Section 2, however, there was not a significant increase in confidence when using cognitive mapping. Further, when both classes were combined, there was not a significant difference in the group's confidence before and after cognitive mapping. All tests were conducted with an alpha value of 0.05.

In short, there is *some* evidence for the utility of using SODA to increase individual confidence in decision making. A few factors may complicate this analysis. The first is that students were exposed to SODA techniques in their assigned reading before the experiment. While it would not be safe to assume that 100% of the students read and understood the material, at least some did, which means that they were perhaps predisposed toward use of the techniques and anticipated insights, which may have altered their confidence ratings. Further, SODA is intended to increase group confidence and the

survey was not designed in this manner; in fact, students were asked their individual confidence ratings based on group discussions. Further experiments better experimental design should aim to analyze the difference in group confidence before and after use of SODA.

With *some* evidence in support of the use of SODA, I set out to investigate the potential effect of SODA I as compared to SODA II in terms of the technique's ability to represent complex problems. This analysis involved two separate examples (the John example and Lost at Sea) across two student populations. I investigated a series of hypotheses using the following format:

$$H_0: \mu_2 = \mu_1 \quad (3)$$

$$H_A: \mu_2 \neq \mu_1 \quad (4)$$

In this case,  $\mu_2$  is the cognitive map statistic using SODA I and  $\mu_1$  is the cognitive map statistic using SODA II. First, an independent-samples t-test was conducted to compare a number of statistics related to the overall complexity of cognitive maps produced by individuals using both SODA I and SODA II. These statistics included the total number of components, total connections, density (number of connections/total possible connections), connections/component, and complexity score (# of receiver components/# of driver components). Note that receiver components are those that only have incoming arrows, while driver components only have outgoing arrows. Each of these is a differing measure of complexity for a cognitive map, and therefore a proxy of an relative richness of problem understanding and representation.

For the John example, Group 1 (SODA II, n=5) was compared with Group 2 (SODA I, n=3) using an independent-samples t-test. Table 2 shows the results of this analysis. For all of the John example complexity measures, no significant difference was found in the mean values. Thus, we failed to reject any of the null hypotheses at an alpha value of 0.05.

**Table 2: Summary Statistics for John Example**

Statistic	Total Components	Total connections	Density	Connections Per Component	Complexity Score
$\mu_1$	12.000	27.600	0.220	2.279	0.396
$\sigma_1$	2.915	10.784	0.090	0.601	0.109
$\mu_2$	13.000	26.333	0.150	1.893	0.643
$\sigma_2$	2.646	18.610	0.062	1.097	0.337
p-value	0.645	0.905	0.288	0.534	0.164
Significant at $\alpha=0.05$ ?	No	No	No	No	No

Next, for the Lost at Sea example, Group 1 (SODA II,  $n=3$ ) was compared with Group 2 (SODA I,  $n=5$ ) using an independent-samples t-test. Table 3 shows the results of this analysis. The connections per component metric showed a significant difference. Specifically, students using SODA II (group map composition) had significantly more connections per component than students using SODA I (individual and then group map composition).

**Table 3: Summary Statistics for Lost at Sea Example**

Statistic	Total Components	Total connections	Density	Connections Per Component	Complexity Score
$\mu_1$	19.00	32.67	0.31	1.78	3.67
$\sigma_1$	6.08	7.51	0.30	0.33	2.52
$\mu_2$	20.40	26.20	0.07	1.28	9.20
$\sigma_2$	3.97	6.87	0.02	0.18	4.87
p-value	0.70	0.26	0.11	0.03	0.12
Significant at $\alpha=0.05$ ?	No	No	No	Yes	No

Finally, results of the two examples (John and Lost at Sea) were combined. For this combined population, Group 1 (SODA II,  $n=8$ ) was compared with Group 2 (SODA I,  $n=8$ ) using an independent-samples t-test. Note that tests for total components and total connections were not included. This is because the two examples involved differing levels of complexity and these measures are not normalized. The other metrics are normalized, however, and can be combined across examples. Table 4 shows the results of this analysis. The density metric showed a significant difference. Specifically, students using SODA II (group map composition) had significantly higher density in their maps than students using SODA I (individual and then group map composition).

**Table 4: Summary Statistics for Combined Population**

Statistic	Density	Connections Per Component	Complexity Score
$\mu_1$	0.253	2.091	1.831
$\sigma_1$	0.180	0.552	4.111
$\mu_2$	0.099	1.511	0.623
$\sigma_2$	0.055	0.679	0.820
p-value	0.036	0.082	0.429
Significant at $\alpha=0.05$ ?	Yes	No	No

We can therefore say there is *some* statistical evidence for the claim that the use of SODA I and SODA II produce different representations of complexity. Specifically, in the Lost at Sea analysis, SODA II produced a significantly higher number of connections per component than SODA I. Further, in the combined population, SODA II produced a significantly higher density map than SODA I. These are interesting findings as SODA II involves group map composition and literature shows that SODA II helps with map ownership and buy-in [14], which would seem to favor a simpler representation of a problem, yet experimental analysis showed some evidence that the opposite phenomenon is true. That is, greater buy-in *may be* achieved when a more complex problem representation is generated.

### **Conclusions and Future Research**

Problem structuring methods are espoused by many researchers and practitioners as being useful in the context of framing and understanding wicked problems. However, empirical evidence for their use is lacking. Specifically, Strategic Options Development and Analysis (SODA) I, in which individual participants build maps and then create a group cognitive map, and SODA II, in which individual maps are bypassed in favor of a collectively built group map, were investigated. The aim of this empirical analysis was to investigate whether or not group confidence improved after exposure to SODA and whether or not SODA I or SODA II led to more complex problem representation.

A number of hypothesis tests were undertaken based on instructor-led student exercises. Many of these tests failed to reject the null hypothesis that a difference was present, however some significant findings were determined. In one of the three student populations investigating the John example, there was a significant increase in confidence after using cognitive mapping. Further, in one of the three student populations, students using SODA II (group map composition) had significantly more connections per components than students using SODA I (individual and then group map composition). Finally, in the combined population of students, SODA II produced a significantly higher density map than SODA I.

While these experiments demonstrate some significant findings regarding the utility of SODA I and SODA II in understanding complex problems, it is clear significantly more analysis is needed. Further experimentation is necessary to determine group confidence in the use of these techniques (as opposed to individual confidence), as well as additional experiments to determine the stability of these findings across populations (e.g, working professionals or students not exposed to these techniques). This paper, however, has provided some initial evidence regarding the efficacy of these techniques.

### **REFERENCES**

- [1] Adams, K. M., & Hester, P. T. (2012). Errors in systems approaches. *International Journal of System of Systems Engineering*, 3(3/4), 233–242.

- [2] Adams, K. M., & Hester, P. T. (2013). Accounting for errors when using systems approaches. *Procedia Computer Science*, 20, 318–324.
- [3] Axelrod, R. (1976). *Structure of decision: The cognitive maps of political elites*. Princeton, NJ: Princeton University Press.
- [4] Carvalho, J. P. (2013). On the semantics and the use of fuzzy cognitive maps and dynamic cognitive maps in social sciences. *Fuzzy Sets and Systems*, 214, 6-19.
- [5] Eden, C.L. (1989). Using cognitive mapping for strategic options development and analysis (SODA), *Rational analysis for a problematic world*, ed. By Rosenhead J. Wiley & Sons, Ltd., Chichester, UK.
- [6] Eden, C., & Ackermann, F. (1998). *Making strategy: The journey of strategic management*. London: Sage.
- [7] Gray, S.A., Gray, S., Cox, L.J., and H.-S., S. (2013). Mental Modeler: A fuzzy-logic cognitive mapping modeling tool for adaptive environmental management. In *Proceedings of the 2013 46th Hawaii International Conference on System Sciences (HICSS '13)*. IEEE Computer Society, Washington, DC, USA, 965-973.
- [8] Hester, P. T., & Adams, K. M. (2014). *Systemic thinking: Fundamentals for understanding problems and messes*. Cham, Switzerland: Springer International.
- [9] Hester, P.T., & Adams, K.M. (2017). *Systemic decision making: Fundamentals for addressing problems and messes*. Cham, Switzerland: Springer International.
- [10] Heyer, R. (2004). *Understanding Soft Operations Research: The methods, their application and its future in the Defence setting (DSTO-GD-0411)*. Edinburgh, Australia: DSTO Information Sciences Laboratory.
- [11] Hill, B. (2013). Confidence and decision. *Games and economic behavior*, 82(C), 675-692.
- [12] Kotiadis, K., & Mingers, J. (2006). Combining PSMs with hard OR methods: the philosophical and practical challenges. *Journal of the Operational Research Society*, 57(7), 856-867.
- [13] Papageorgiou, E.I. (Ed.). (2014). *Fuzzy cognitive maps for applied sciences and engineering: From fundamentals to extensions and learning algorithms*. Berlin: Springer.
- [14] Pidd, M. (2009). *Tools for thinking: Modelling in Management Science (3<sup>rd</sup> ed.)*. John Wiley, Chichester, UK.
- [15] Pidd, M., & Woolley, R. N. (1980). A pilot study of problem structuring. *The Journal of the Operational Research Society*, 31(12), 1063-1068.
- [16] Rosenhead, J. V. (2006). Past, present and future of problem structuring methods. *Journal of the Operational Research Society*, 57, 759–765.
- [17] Rosenhead, J. V., & Mingers, J. (2001). *Rational analysis for a problematic world revisited (2<sup>nd</sup> ed.)*. Chichester, England: Wiley.
- [18] Sniezek, J. A. (1992). Groups under uncertainty: An examination of confidence in group decision making. *Organizational Behavior and Human Decision Processes*, 52(1), 124-155.

## **ASSESSING DATA NORMALITY WHILE USING RESOURCES ACROSS MULTIPLE DISCIPLINES**

Anna J. Johnson-Snyder\*, East Carolina University, 312 Slay Hall/MS 503, Greenville, NC  
27858, 252-737-1296, JohnsonAn18@ecu.edu

Brenda L. Killingsworth, 329 Slay Hall/MS 503, Greenville, NC 27858, 252-328-6235,  
killingsworthb@ecu.edu

### **ABSTRACT**

Experimental researchers frequently find violations of the normality assumption in dependent variables after a survey has been designed and implemented. Sources are split on which tests or methods to use when addressing such normality issues. Researchers must traverse these resources to ascertain what source to use as support for data analyses. In this research, we summarize advice found across multiple disciplines on how to address normality assumption violations.

### **INTRODUCTION**

You did everything you were supposed to do correctly, according to many knowledgeable experimental research and psychometric sources and mentors, to theoretically support and meticulously create an instrument to conduct an experimental study. The instrument was vetted, adjusted, and reassessed based on feedback from many professional and academic sources, pilot-tested multiple times, and successfully passed the long Internal Review Board process. After many months of “beating the bushes” of personal and professional sources of academic colleagues and friends, you finally obtain “enough” of the target participants to complete the study to find that you have nonnormal dependent variables.

This issue does not deter you; instead you research books and academic articles to determine how to proceed with non-normal variables. Unfortunately, the advice widely varies between sources and disciplines. Furthermore, you seek suggestions from more advanced researchers and discover the guidance varies within the discipline too. Does this sound familiar? If so, you are not alone. If you have not had this problem and if you are an experimental researcher, odds are you will eventually have a similar problem sometime in your career as well.

This “small” problem does not “ruffle your feathers” – you reach for your beloved research books and articles to discover the advice on how to handle a nonnormal dependent variable drastically varies between sources. Not to be deterred, you solicit an understanding from more experienced researchers only to learn the advice is mixed amongst researchers within disciplines.

### **THE ISSUE**

Prior to conducting an analysis, one needs to assess the parametric assumptions. According to Dugard, Todman, and Staines [1], the hypothesis can be tested if the dependent variable is

approximately normally distributed. Nonparametric tests (e.g., chi-square, Mann-Whitney U, Spearman rho) can be performed when the parametric assumptions are violated [7], for the nonparametric test assumptions are “less restrictive [3, p. 5].

A brief discussion in Kerlinger and Lee [7] showed mixed guidance on whether to choose parametric versus nonparametric tests. For instance, “social science data are generally imprecise... [and] only the most conservative (nonparametric) statistical methods should be used on the data” while others argued that it was acceptable to use “parametric methods for questionable data” or for nonnormal data [7 p. 415]. Yet, if the data was to be used to make inferences, the “power of this analytical deduction is illusory” [7 p. 415]. Considering we want to make inferences from our data analysis, we elect to use parametric tests, which require an assessment of assumptions, which explain “when it is and isn’t reasonable to perform a specific statistical test” [10, p. 55].

The parametric assumptions for multivariate analysis are normality, homogeneity of variance, independence of observations, and that multicollinearity between the dependent variables is not an issue. In this paper, the mixed advice of most interest is that pertaining to the normality assumption. Hence, issues with other assumptions are not discussed.

Individual variables can be examined for multivariate normality assumption violations by assessing normality (i.e. skew and kurtosis), linearity, and homoscedasticity [3][8][13] as one would for a univariate [11]. “[I]t is only in rare cases that multivariate nonnormality will not be detected by univariate normality tests” [11, p. 375].

Is normality really needed? Almost all parametric tests use a derivative of a significance assessment that necessitates multivariate normality, where normality of each variable and linear combination of all variables is assumed [11][13]. To determine whether it is needed, the normality of each variable must be checked [6, p. 63].

Normality or symmetry of a normal distribution is based on the level of skewness and kurtosis of the data plot and whether the relationship between paired variables is linear [13]. Skewness describes the symmetry of a distribution. The more skewed the distribution, the more likely the variable mean does not represent the distribution center [13]. Kurtosis is the “peakedness” of the distribution, which can be too flat (long, thin tails) or peaked (short, thick tails) [13, p. 73]. Linearity describes whether paired variables have a straight-line relationship, which impacts the Pearson's rho (or r). The level of association between the paired variables is captured by Pearson's r [13].

The normality of variables can be determined by using graphing methods (e.g., residual plot, Q-Q plot, stem-and-leaf plot or normal probability plots) or statistical (e.g., Kolmogorov-Smirnov test and Shapiro-Wilks test). Bivariate graphs, such as the residual plot, are used to assess linearity. Yet, after many authors suggesting we check normality, Tabachnick and Fidell state that “if there are substantial nonlinear relationships among variables, they are [to be] ignored” [13, p. 77].



It appears that researchers have favorite graphical methods. For instance, Sharma [11] claims that the most popular method is the Q-Q-plot while Huberty [6] prefers the normal probability plots. Some use the box-and-whiskers plot or the residual plot [3][11]. Different data plots showed that our dependent variable was within normal standards visually, but that may be attributed to it being based on a 7-point Likert scale item. Hence, we decided to perform the recommended statistical tests.

The primary tests used to assess data normality are the Kolmogorov-Smirnov test and the Shapiro-Wilks test. “[T]hey compare the scores in the sample to a normally distribution set of scores with the same mean and standard deviation” [4, p. 144]. A non-significant p-value ( $> 0.05$ ) suggests that the data is not significantly different from a normal distribution [4]. The statistical values were significant, further confirming that our dependent variable was nonnormal. So, we asked ourselves- what is considered nonnormal?

Tabachnick and Fidell [13] state that a normal distribution has a kurtosis index, computed value minus 3.0, of zero while Byrne [2] claims that a normal distribution has a standardized kurtosis index ( $\beta_2$ ) of 3.0. Regardless of the assessment approach used, you must be consistent in its application. A normal distribution kurtosis value based on the original kurtosis value or standardized kurtosis index that should equal 3.0 while that based on the kurtosis index should be zero [2][13].

Kurtosis values that are considered extreme vary even more greatly. For instance, Byrne [2] suggests that anything greater than absolute 5.0 is nonnormal while Bentler [1, p. 110] believes the values of absolute of 5.0 to 6.0 are “nontrivial.” Others (e.g. [1][8] argue that absolute values greater than 7.0 are nonnormal.

### **IS NORMALITY REALLY NEEDED?**

Although normality violations do not have a noticeable effect on the Type I error [11] and it isn't always needed for an analysis [13], it also indicates that the analysis results may be degraded [13] and that there may be violations of other assumptions [5][11]. For example, a nonnormal kurtosis effects test statistic power [11] and may result in an underestimate of variance [13]. Moreover, the normality assumption applies “differently to different multivariate statistics,” depending on whether the data is grouped or ungrouped [13, p. 72]. Thus, normality violations must be remedied prior to assessing other assumptions [5].

### **TO TRANSFORM OR NOT TO TRANSFORM- THAT IS THE QUESTION**

Suggestions from many sources vary from transformation to doing nothing to improve the normality of a dependent variable. Scholars that suggest data transformation (e.g., [3][4][6][7][8][11][13] taught its benefits adjust the data to conform to the “quoted probabilities” in making inferences [3, p. 20], potentially corrects skew and kurtosis problems [8], and improve “doubtful measures” [7, p. 419].

Based on the various recommendations, there are roughly eight possible types of data transformations: (1) logarithmic; (2) roots (3) recoding; (4) reciprocal; (5) sine function; (6) Fisher's Z or standardization; (7) linear; and (8) trimmed mean.

Again, the advice from one source is contradictory in that, Dugard et. al. [3] states "[p]articular types of transformation are often recommended for particular types of violations of parametric assumptions, and then later states, "there is nothing wrong with trying out several and seeing which does best in terms of meeting parameter assumptions" (p.20). This method is referred to as "trial and error" [8, p. 64] and is not recommended. Rather, Kline [8] suggests using the Box-Cox transformations that, if conducted, will require less "trial and error" to determine which transformation is best to correct normality problems (p. 64). However, the process will only work for positive data values. Again, you will have to perform another type of transformation to eliminate the negative values prior to using the Box-Cox process [8].

There are drawbacks to transformation, such as loss of the original variable scale [8], results of the transformed scores must be translated or the inferences no longer directly apply as it would with the original scores [8], and/or no transformation will improve the severely nonnormal data [8]. Thus, transformation should only be used to correct nonnormal data "unless there is some compelling reason not to" [13, p. 72] and is "interpretability is not sacrificed" [3, p. 20]. As previously mentioned, there are scholars that believe nothing should be done to alter the integrity of the original data.

### **DO SOMETHING OR DO NOTHING- THAT IS THE QUESTION.**

Scholars advocating doing nothing about nonnormal data offer convincing arguments. For instance, some researchers argue that transformation or altering the original data "feels like cheating" [3, p. 20]; assessing whether data is or is not normal, in practice, "is not easy" and may not be accurate [3, p. 20]; altering the data may result in a loss of information [8]; nonparametric tests can be performed [3][7]; and assumption violations are "not so serious" because the t- and F- tests, ANOVA, and MANOVA are robust, meaning that the tests are reliable even when there are assumption violations [7, p. 415].

Suggested nonparametric tests for dependent variable normality violations include the (1) Mann-Whitney test, which is analogous to the t-test for independent samples (Dugard et al., 2010); (2) Wilcoxon signed rank test, a substitute for the paired samples t-test or when you have an ordinal dependent variable [9]; and the Kruskal-Wallis test, an alternative for a one-way ANOVA [7].

Parametric analysis using t- and F- tests and ANOVA are recommended if the violations are "not gross and multiple" [3][7, p. 415] and a MANOVA is suggested if you have approximately equal sized groups [9]. However, sample size may also dictate whether or not you can apply one of these parametric tests.

According to the Central Limit Theorem, the mean of variables, that are independent of each other, in a large sample size will approximate normal distribution even if individual variables

are not as long as outliers are not present [13]. In other words, if there are no outliers and the sample size is of a certain size, the observations within the variables will be normal. Tabachnick and Fidell [13] report that positive (negative) kurtosis “disappears” when a sample size has over 100 (200) observations. Hence, a “sufficiently large” sample, depending on whether all observations are positive (negative), can be defined as over 100 (200) observations [13, p. 73].

### **EXTREME ADVICE - BUT SOUND**

Huberty [6] states,

“If one is satisfied with multiple univariate normality, he or she might proceed as though the multivariate normality condition is met. Or one can proceed ‘blindly,’ assuming, without any checks, that the condition is met. If it can be assumed that the sample observations used are typical of those in the populations, logically there is no problem with ‘working in the dark,’ so to speak. If a normal rule is built on nonnormal data and then used on similar nonnormal data, the rule used may not be the most efficient one. However, it may be claimed that ‘this is what I will get if I assume normality’ “[italics added for emphasis] (p. 63).

Although Hubert’s [6] statement may be a bit extreme, it makes sense and is consistent with other comments. Field [4] argues that transformation is not always the best solution- it may solve one problem while creating many more. In one example in the Hair et al. [5] textbook, the normality of one variable could not be improved by any of the attempted transformations, resulting in the use of the original variable scores. The authors conclude that “departures from normality are not so extreme in any of the original variables that they should never be used in any analysis in their original form [5, p. 82].

### **RECOMMENDATIONS**

Although the scholars’ advice spans from using a nonparametric test to doing nothing, overall, they do provide some excellent advice on what to do when your dependent variable is nonnormal. Thus, we recommend the following procedures:

1. Rather than ignoring the problem, check whether your dependent variable is nonnormal.
2. In what way is the variable nonnormal? Is skewness, kurtosis, linearity an issue? Are the values “acceptable”? If so, continue by assessing the other assumptions (do not proceed to the next step). However, if the values are not acceptable, review to determine which type of transformation is appropriate or use the Box-Cox transformation process. “Remember that there is rarely one obviously correct measurement scale for a construct” [3, p. 20].
3. Did a transformation improve data normality? If so, continue with assessing the other assumptions (do not proceed to the next step). However, if normality did not improve, continue to step 4.
4. At this point, you may want to determine whether or not to recode the data into dummy variables or choose a conduct a statistical test. If you choose to recode the

- data, continue with assessing the other assumptions (and do not proceed to the next step). However, if you choose to conduct a statistical test, you have some decisions you need to make.
5. Assuming normality is still an issue, you must either ignore it and use a nonparametric test or choose a technique that is robust to normality issues [5]. Regardless of the decision, the original variable(s) may be used for interpretation of the results.

### REFERENCES

- [1] Bentler, P. M. 2006. *EQS 6 Structural Equations Program Manual*. Encino, CA: Multivariate Software, Inc. Retrieved (<http://www.econ.upf.edu/~satorra/CourseSEMVienna2010/EQSManual.pdf>).
- [2] Byrne, B. M. 2009. *Structural Equation Modeling with Amos: Basic Concepts, Applications, and Programming*. 2nd ed. New York, N.Y.: Routledge Taylor & Francis Group.
- [3] Dugard, P., J. Todman, and H. Staines. 2010. *Approaching Multivariate Analysis: A Practical Introduction*. 2nd ed. New York: Routledge.
- [4] Field, A. 2009. *Discovering Statistics Using SPSS*. 3rd ed. Thousand Oaks, CA: Sage Publications, Inc.
- [5] Hair, J., W. Black, B. Babin, and R. Anderson. 2010. *Multivariate Data Analysis: A Global Perspective*. 7th ed. edited by J. Leale (Senior Editor). Upper Saddle River, N.J.: Pearson.
- [6] Huberty, C. J. 1994. *Applied Discriminant Analysis*. New York, N.Y.: John Wiley & Sons, Inc.
- [7] Kerlinger, F. N. and H. B. Lee. 2000. *Foundations of Behavioral Research*. 4th ed. Orlando, FL: Harcourt College Publishers.
- [8] Kline, R. B. 2011. *Principles and Practice of Structural Equation Modeling*. 3rd ed. New York, N.Y.: The Guilford Press.
- [9] Leech, N. L., K. C. Barrett, and G. A. Morgan. 2011. *IBM SPSS for Intermediate Statistics: Use and Interpretation*. 4th ed. New York: Routledge Taylor & Francis Group.
- [10] Morgan, G. A., N. L. Leech, G. W. Gloeckner, and K. C. Barrett. 2013. *IBM SPSS for Introductory Statistics*. 5th ed. New York, N.Y.: Routledge Taylor & Francis Group.
- [11] Sharma, S. 1996. *Applied Multivariate Techniques*. New York, N.Y.: John Wiley & Sons, Inc.
- [12] Shaughnessy, J. J., E. B. Zechmeister, and J. S. Zechmeister. 2006. *Research Methods in Psychology*. 7th ed. New York, N.Y.: McGraw-Hill Higher Education.
- [13] Tabachnick, B. G. and L. S. Fidell. 2001. *Using Multivariate Statistics*. 4th ed. edited by R. Pascal. Boston, MA: Allyn and Bacon.

**DEVELOPING BETTER SURVEYS: APPLYING TOPIC MODELING AND SENTIMENT ANALYSIS FOR ITEM AND SCALE DEVELOPMENT**

Sven-Volker Rehm, EM Strasbourg Business School, HuManiS EA 7308, 61 avenue de la Forêt-Noire, 67000 Strasbourg, France, sven.rehm@em-strasbourg.eu  
Mark Hartley, College of Charleston, School of Business, Department of Supply Chain and Information Systems, 66 George Street, Charleston, SC 29424, hartley@cofc.edu  
Iris Junglas, College of Charleston, School of Business, Department of Supply Chain and Information Systems, 66 George Street, Charleston, SC 29424, junglasia@cofc.edu

**ABSTRACT**

Surveys are a dominant research method of choice in social as well as Information Systems disciplines. They measure, most often, evaluative constructs that are latent in nature. Because latent constructs cannot be measured directly, they are captured by observable indicators that can be seized and quantified. But when developing indicators, researchers must understand that evaluative constructs have no conceptual meaning independent from the procedures used to measure them, and more importantly, “*changes in measurement procedures change the meaning of a theoretical construct*” [1, p. 265]. This interconnectedness makes it difficult to separate one from the other; it also makes it difficult to produce measures for evaluative constructs that are content valid, yet adaptable to their inherent changing nature and context.

In contrast to measuring evaluative constructs via surveys, online reviews provide unsolicited evaluations of products (or services) in a free-style format, written by individuals that have put time and effort into charting down their thoughts. As qualitative data, online reviews are “raw” and rich in authenticity. It is this “rawness”, or the direct link between thought and written expression, that can be harnessed to find the best measure for an evaluative, or latent, construct.

In this abstract, we propose a combination of topic modeling and neural sentiment analysis to streamline and introduce additional rigor to the item development process for evaluative constructs. While topic modeling (or Latent Dirichlet Algorithm) is an example of an unsupervised approach to text analysis that uncovers hidden structures (or themes) based on probabilities of co-occurrences, neural sentiment analysis detects the mood that is expressed in-text. The application of topic modeling ensures that survey measurement items capture the universe of interest and represent an existing topic; the application of sentiment analysis assists in safeguarding that the scale chosen for each measurement item is a valid one to take. For example, based on a set of reviews topic modeling might identify a range of themes that users talk about and that are important for them to evaluate a product (or service). Sentiment analysis, on the other hand, provides an indication about the positivity (or negativity) of the topic. By utilizing both, researchers will be able to leverage machine learning mechanisms—more specifically a tool developed and available at [minemytext.com](http://minemytext.com)—to enhance the content validity of measures, along with the proper anchoring of scales, for an advanced survey design.

[1] Bagozzi, R. P. Measurement and Meaning in Information Systems and Organizational Research: Methodological and Philosophical Foundations. *Management Information Systems Quarterly*, 2011, 35(2), 261-292.

**ESTIMATING THE WEIGHTED AVERAGE COST OF CAPITAL OF OPERATING ASSETS**

Timothy Vines, College of Business, Louisiana State University in Shreveport, One University Place, Shreveport, LA 71115, 318-797-5013, timothy.vines@lsus.edu

Chengho Hsieh, College of Business, Louisiana State University in Shreveport, One University Place, Shreveport, LA 71115, 318-797-5015, chengho.hsieh@lsus.edu

**ABSTRACT**

A firm's total assets includes non-operating and operating components. In the conventional value-based management and economic value added models, the value created comes from the firm's operating assets; therefore, the weighted average cost of capital in the models should also be based on the operating assets instead of the total assets. A method to find this cost of capital is presented.

## **FLIGHT DISRUPTION INSIGHTS WITH BIG DATA ANALYTICS**

Krishna Bathula, Seidenberg School of CSIS, Pace University, 861 Bedford Road,  
Pleasantville NY 10570, 914-773-3989, kbathula@pace.edu  
Kaleemunnisa LNU, Seidenberg School of CSIS, Pace University, 861 Bedford Road,  
Pleasantville NY 10570, 914-773-3989, klnu@pace.edu  
Charles C. Tappert, Seidenberg School of CSIS, Pace University, 861 Bedford Road,  
Pleasantville NY 10570, 914-773-3989, ctappert@pace.edu

### **ABSTRACT**

Data is growing exponentially and in different forms such as structured, unstructured and semi-structured. This study uses big data analytics concepts and machine learning algorithms to work with structured data of flights, airports, airlines, and weather information. The objective is to represent the correlation between different data points among the datasets and to use these associations to identify the key features that can disrupt flight schedules and, in turn, direct the investigation into the area of impact analysis. The domino effect that is passed on to the stopovers and connecting flights en-route to the original flight destinations is also predicted. These insights can provide the basis for disaster management and recovery of valuable air time as the delays in flights influence the economy of airport authority, airlines and flyers, as well as causing damage to the environment due to the increased consumption of utilities like fuel.

Index Terms—Big data analytics, data science, data mining, flight schedule disruptions, flight delays, flight delays by weather analysis.

### **INTRODUCTION**

The U.S. Department of Transportation (DOT) tracks the punctuality of domestic flight arrivals operated across the USA by large airlines. This statistical information has an apparent increase of air transportation in recent years, and points towards progressively congested airports and airspaces. This extensive usage of airspace reflects the heightened risk of operational disruptions that can be traced to delays, cost criteria, deteriorated quality of service, airline setbacks, passenger discontent, etc. In addition to these, airlines are constantly finding numerous strategies in optimizing their operational profits above competing with their counterparts. It is a challenging task to balance higher turnover with customer gratification and sustainability [3].

As per the analysis done by Bureau of Transportation Statistics (BTS), nearly 20% of commercial air transport run out of scheduled time. Which results in heavy losses to airline companies as well as superfluous distress to customers. Weather is contributing factor significantly in flights delay as well as late arrivals. The study of prediction of delay in flights is vivacious area of research as demands for air travel increase. According to the U.S. Department of Transportation's Air Travel Consumer Report, in January 2017 alone, all

the airlines of United States of America, recorded a mean on-time arrival frequency of 76.0 percentage, down from 81.0% compared to 2016 data and up to 82.5% in the final quarter of 2016. Thus, various studies were attempted earlier to determine patterns in air traffic and flight schedule deviation from the actual planned.

In this study, we focus on the flight disruptions that arise from air system delays, security delays, airline delays, late aircraft delays and weather delays. Our aim is to find the correlation between attributes like flights and weather and whether we must consider all the constraints that effect delays or just the ones that have major impact. This impact analysis further provides grounds for determining the influence of these delays to the connecting flights from the destinations. The data from various datasets are observed for the features that effect the overall delays. These patterns in the itinerary and delays can be used to predict the possible future delays. We use data science algorithms to do in-depth study of several key factors that contribute to the airline performance factor and determine the correlation among these characteristics. We also propose a model that will predict the flight disruptive phenomenon with respect to climate changes and forecast the repercussions to the consecutive flight patterns, one such instance being the connecting flights. These observations will help the airline industry to take essential precautions for operational effectiveness, time and wealth optimizations.

### LITERATURE REVIEW

According to the latest reports by the Bureau of Transportation Statistics, U.S. Department of Transportation [5], the on-time flights are 78.37%. The rest of 19.68% constitutes to the delay in schedule. A flight can be announced delayed if it arrives more than 15minutes than planned schedule. Although the various reasons for delay like weather, security, National Aviation System (NAS) delay etc., are considered, if there are multiple reasons contribute to a delay, each source is prorated based on the deferred minutes. The results for on-time arrival are analyzed from the source of the historical data from June 2003 to August 2019 (Fig. 1).

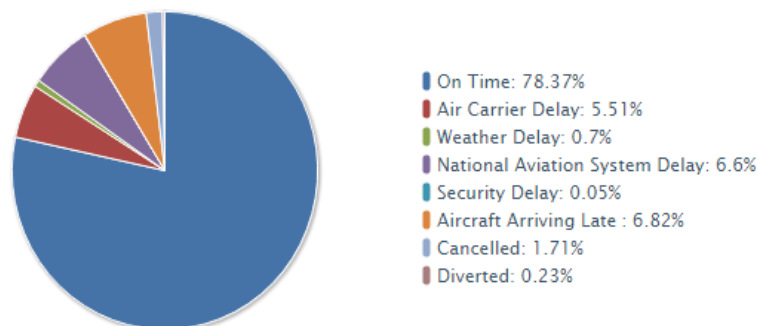

Fig. 1. U.S. Department of Transportation Statistics [5].

If the historical data is further prompted for the exact cause of delay, the study yields weather as the much incriminating factor with almost 72.99% than the others (Table 1).



All these measures are based on the number of flight operations.

Table1. Flight Delay Analysis Report (Source: BTS, DOT).

<b>Causes of National Aviation System Delays National (June, 2003 - August, 2019)</b>				
	Number of Operations	% of Total Operations	Delayed Minutes	% of Total Delayed Minutes
Weather	4,384,592	61.89%	237,732,919	72.99%
Volume	1,831,716	25.86%	57,336,563	17.60%
Equipment	51,160	0.72%	2,324,560	0.71%
Closed Runway	564,633	7.97%	19,546,609	6.00%
Other	252,329	3.56%	8,786,129	2.70%
<b>Total Operations</b>	<b>7,084,430</b>	<b>100.00%</b>	<b>325,726,780</b>	<b>100.00%</b>

Rebello et al. have created indicative model predicting network-related interruptions of the forthcoming by applying the system-level dependences between airports [8]. In a similar fashion, Hansen et al. analyzed the advancement in flying delays in the United States, domestic system by assessing an econometric model of systematic routine delay that combines the properties of arrival line up such as terminal weather situations, seasonal and secular impacts. The results suggested that even after monitoring these factors overall, the delays decreased gradually from 2000 through mid-2003, but the trend inverted drastically thereafter [6].

Another group of researchers Mueller et al, developed a statistical method to analyze the departure, arrival data and characterize the delay data [7]. Belcastro et al. [2] developed a model that govern onset delay prediction of a scheduled flight. On the other hand, Choi et al. [4] have anticipated a model to forecast carrier onset interruptions caused by inclement weather situations using data mining techniques and supervised machine learning algorithms.

Over a period, numerous analytical models and simulation methods have been developed to analyze flight delay, which includes deterministic queuing models, neural networks, econometric models etc.

## METHODOLOGY

In this research we are predicting the flight delay due to weather disruption, which can help airlines and passengers to have appropriate plan of action. In this paper we will be using machine learning techniques for predicting the delay.

The project is divided in to 3 different parts, one is the Data Engineering, the second is the Exploratory Data Analysis and the last is the prediction of the connecting Flight Disruptions.

The initial step towards a successful Data Analysis is ensuring the Data Quality. The Airline data is fetched from Department of Transportation US (DOT). And the source of Weather data is from National Oceanic and Atmospheric Administration (NOAA).

## Data Preprocessing

Data is thoroughly examined for integrity criteria as well. Since we expect the model to work with all the forms like offline, near line and online data, we curtailed the irrelevant and unnecessary parameters that could overburden the dataset. We have also dropped the null values and assigned zero to Not a Number (NaN) values as one of the data cleansing activities. The data types of time factors such as scheduled time, airtime etc., are found to be in float point and needs proper conversion of input time to standard date time format. The categorical data is assigned with proper numeric values which are the most contributing factors that flag the key filters. Finally, the data is analyzed for distribution after cleansing, converting and preprocessing.

Then different datasets such the airline, flight, airports and weather datasets are integrated and normalized to identify the correlating factors that affect the flight cancellations (Fig. 2).

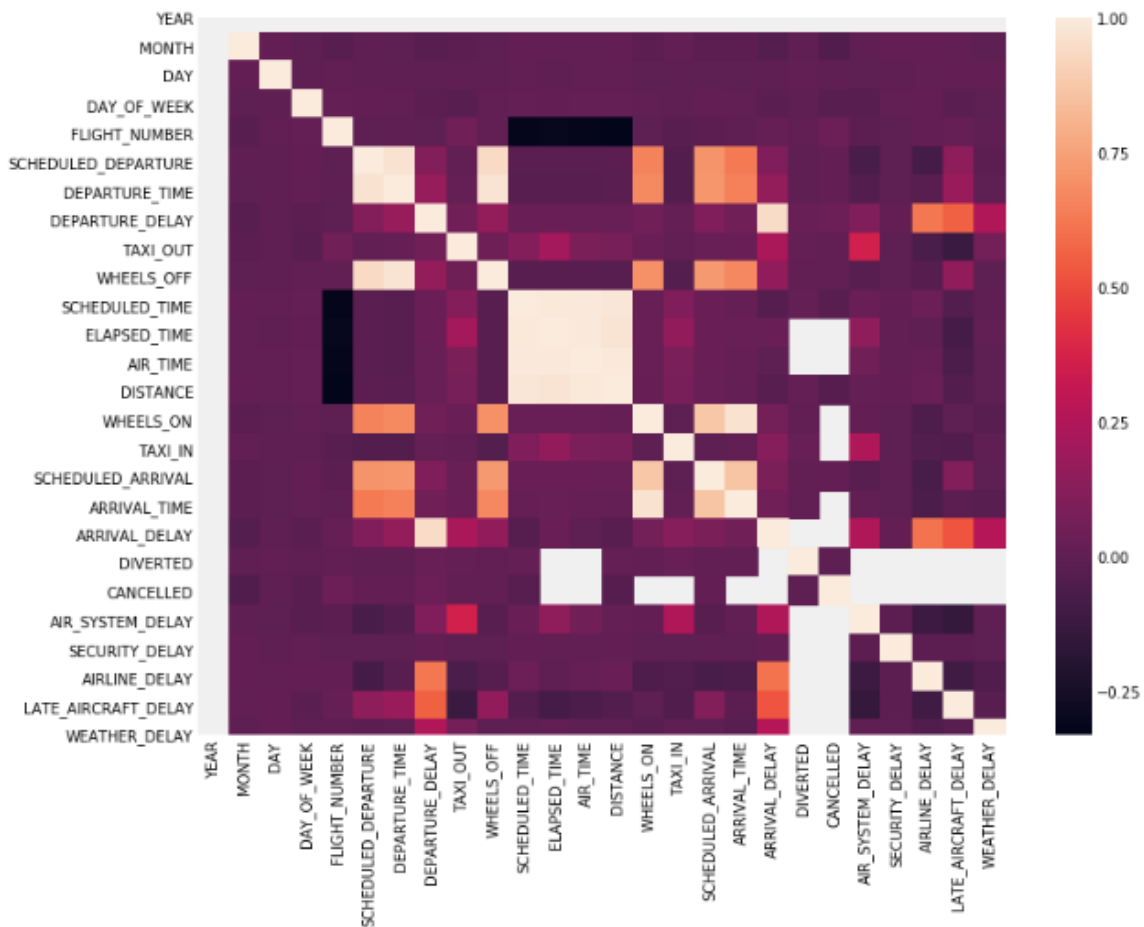

Fig. 2. Feature Correlation.

## Exploratory Data Analysis (EDA)

As part of EDA, the data have been explored in different views. The first EDA is on the number of flights per year at all airports. The distribution of delays by airlines is a reasonable starting analysis as seen in the pair plots of Fig. 3 with respect to the scheduled time, geographical area covered, and the delay incurred. Hence, the airline characteristics will be considered as key features for our model.

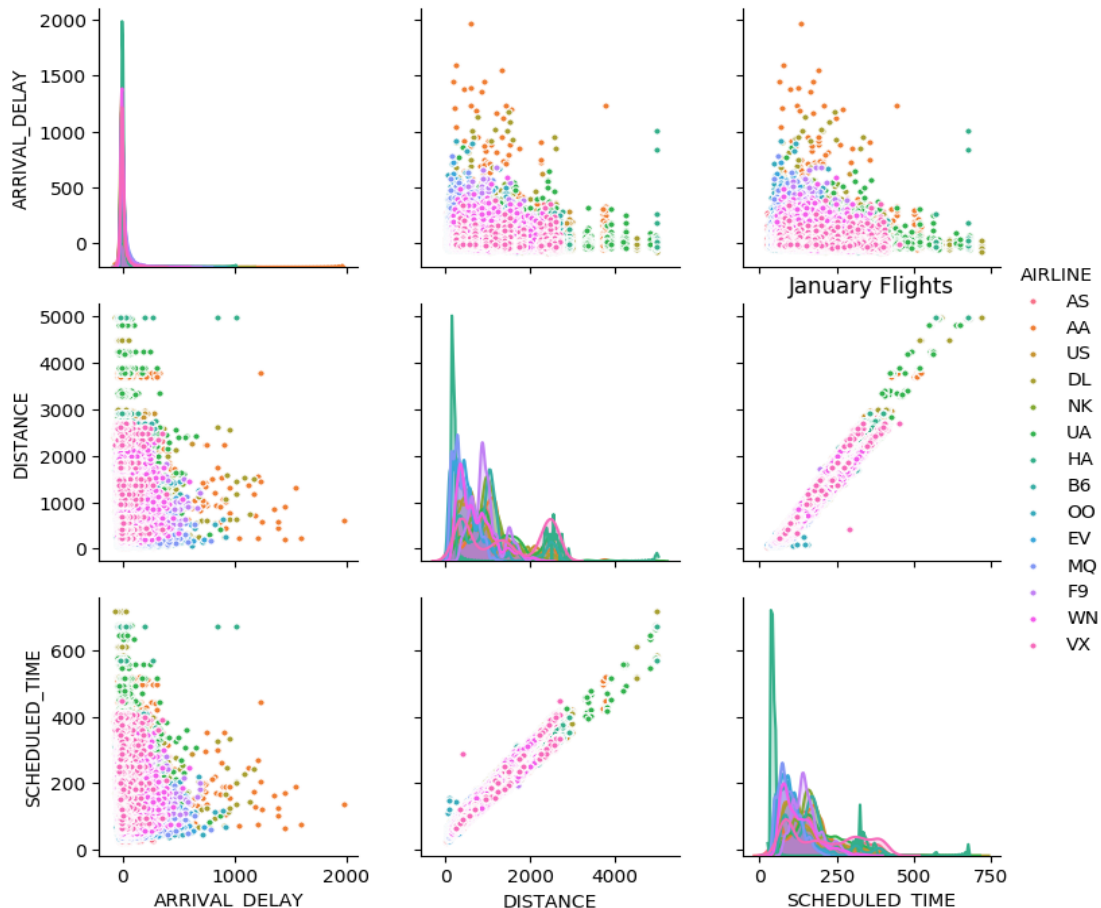

Fig. 3. Pair Plots.

Since all the airlines are operated from airports which can be either an origin or destination. From these data we will be selecting only Top 50 busiest airports. To get the Top 50 we have added departures and arrivals. The predictors are chosen based on their delay factors. The data frame for the small feature set is fitted with Random Forest classifier and extracted Feature importance score for each feature. Such as Departure Delay and Arrival Delay due to weather.

- 1) Departure Delay Prediction: All the feature set utilized in the departure delay forecasting is identified with the help of correlation matrix. Therefore, in predicting the delay, each feature is relatively significant.

2) Arrival Delay Prediction: As departure delays will affect the arrivals, we will be selecting the origin airport.

Data Integration: Top 50 busiest airlines data is integrated to weather data by origin and destination airports at the time of takeoff and landing. While analyzing the data we have found that approximately 65% of the flights originate and land in these airports. The Flight data is integrated with the weather data, for all the weather station, we have considered the average weather parameters, i.e. Annual Mean Temperature, Annual Mean Precipitation, Annual Mean Visibility etc. Two Data Frames are created for simplicity - One for Origin, and one for Destination. They are the same data frames, except for the Column Names.

The delays are plotted against weather conditions such as heavy rains gauged in inches fig.5. The impact analysis plot can be viewed in fig.4

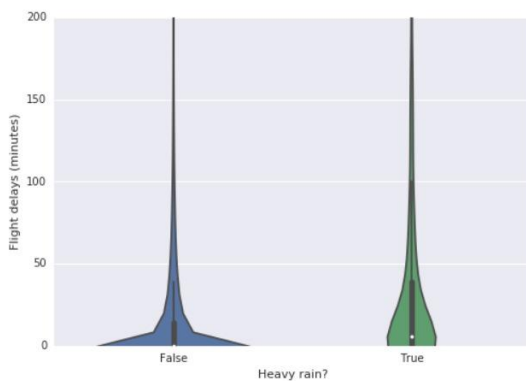

Fig. 4 Rain effected Delays

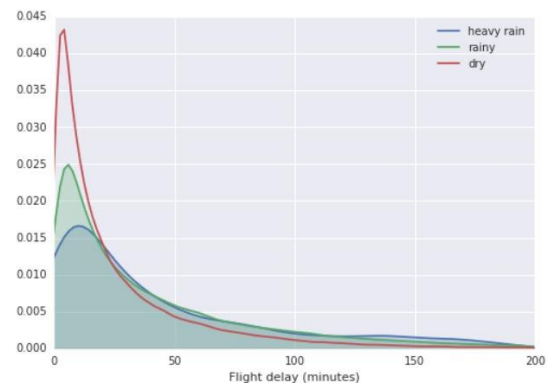

Fig. 5 Delays vs Precipitation Rate

## Model Analysis

The input data is split in to training and testing data. The intent of our model is to predict arrival delay, which gives us the reference window time prediction for the connecting flight. In order to get closer time window that determines if a connecting flight can be boarded by delayed passengers, we start with arrival delay which is vastly tricky, as majority of flights having zero or a small arrival delay. We break the problem into two subparts:

### Delay Classification Model

The threshold of delay factor being more than 5 minutes, we performed binary classification, training a logistic regression model and record resulting P value of the delay i.e., the output probability of delays.

## Predicted Delay

Perform Linear Regression and model trained on positive delays from the above result of binary classification.

### MODEL EVALUATION RESULTS

The model has been trained to predict arrival delays, given flight features such as flight number, origin and destination etc. Additionally, the weather features like precipitation, wind speed, visibility which are primarily key characteristics. To discount the effect of weather on historical delays, we predict arrival delay for each flight with the mean weather conditions of the origin and destination airports.

As per the preliminary results, we were able to obtain 30% of positive prediction Fig. 6, which is on the much lower side. We have selected the K-fold cross validation method which is deterministic. If we try to use more than one model, there is a possibility of overfitting the data and this approach may lead the parameters of the model to be biased. We were able to achieve these results using the regularization techniques.

```
Final Accuracy: 0.712627
TP: 158341
FP: 145880
TN: 554286
FN: 141493
% of positive predictions:
0.304221
```

Fig. 6. Results.

### CONCLUSIONS

With the help of this model airlines and passengers can get advance notice on the expected delays in their journey. This study proposed a prediction model which is Regression using Linear regression. The Logistics Regression Model classifies the delay and Airline delays triggered by extreme weather condition. In specific, the model was built on historic weather and airlines data for top 50 airlines by utilizing machine learning algorithms. The project has incorporated and showed the importance of Regression Analysis in Machine Learning, Big Data Analytics, including Cross Validation technique and Regularization in ML for making proper models. Because the data was imbalanced, we have performed data cleansing techniques. We were also able to infer that there is significant subsequent impact on the connecting flights when there is a delay of greater than 45 minutes in the arrival of the aircraft at the stopover destination.

The model's prediction performance on the validation set and the test set was analyzed. We feel that there are few more possible methods that can be useful to improve the model in the future. Also, for future work we can integrate expenses which could be saved by predicting the delays, every second in delay could lead to losses. We will study on how we can save one percent by avoiding delays which are in control.

## REFERENCES

- [1] Allan, S & Gaddy, S & Evans, J. (2011). "Delay Causality and Reduction at the New York City Airports Using Terminal Weather Information", MIT, Lexington, Massachusetts.
- [2] Belcastro, L. & Marozzo, Fabrizio & Talia, Domenico & Trunfio, Paolo. (2016). "Using Scalable Data Mining for Predicting Flight Delays," *ACM Transactions on Intelligent Systems and Technology*, vol. 8, no. 1, pp. 1-20, 2016.
- [3] Burmester, Gerrit & Ma, Hui & Steinmetz, Dietrich & Hartmann, Sven. (2018). "Big Data and Data Analytics in Aviation." SpringerLink, Springer, Cham, 1 Jan. 1970, [https://link.springer.com/chapter/10.1007/978-3-319-75058-3\\_5](https://link.springer.com/chapter/10.1007/978-3-319-75058-3_5).
- [4] Choi, Sun & Kim, Young Jin & Briceno, Simon & Mavris, Dimitri. (2016). "Prediction of weather induced airline delays based on machine learning algorithms," 2016 IEEE/AIAA 35th Digital Avionics Systems Conference (DASC), Sacramento, CA, 2016, pp. 1-6.
- [5] Federal Aviation Administration "Aviation Data & Statistics." [https://www.faa.gov/data\\_research/aviation\\_data\\_statistics/](https://www.faa.gov/data_research/aviation_data_statistics/).
- [6] Hansen, Mark & Hsiao, Chieh-Yu. (2005). "Going South? An Econometric Analysis of US Airline Flight Delays from 2000 to 2004, Presented at the 84th Annual Meeting of the Transportation Research Board (TRB)", Washington D.C.'05.
- [7] Mueller, Eric & Chatterji, Gano. (2002). "Analysis of Aircraft Arrival and Departure Delay Characteristics," AIAA's Aircraft Technology, Integration, and Operations (ATIO) 2002 Technical Forum, 2002.
- [8] Rebollo, Juan & Balakrishnan, Hamsa. (2014). "Characterization and prediction of air traffic delays," *Transportation Research Part C: Emerging Technologies*, vol. 44, pp. 231-241, 2014.

## **FRAMEWORK AND PATTERNS FOR MACHINE LEARNING AS MICROSERVICES**

Istvan Barabasi Seidenberg School of CSIS, Pace University, 861 Bedford Road,  
Pleasantville NY 10570, 914-773-3989, ibarabasi@pace.edu  
Ronald I. Frank Seidenberg School of CSIS, Pace University, 861 Bedford Road,  
Pleasantville NY 10570, 914-773-3989, rfrank@pace.edu  
Charles C. Tappert Seidenberg School of CSIS, Pace University, 861 Bedford Road,  
Pleasantville NY 10570, 914-773-3989, ctappert@pace.edu

### **ABSTRACT**

This study explores implementing and using machine learning in an easy, scalable, and sustainable way to solve common everyday problems. There are multiple challenges with new technology adoption and constraints around accessing and using data, running computational workload, especially when using multiple cloud vendors and proprietary technologies. The paper proposes adopting the microservices architecture style to implement and practice machine learning, applicable for a broad set of machine learning frameworks and algorithms.

**Keywords:** machine learning, deep learning, data analytics, microservices, containers, cloud native, open source.

### **INTRODUCTION**

Machine Learning (ML) is an application of artificial intelligence (AI) that automatically learns from data and is able to make guesses and predictions that are statistically verifiable as accuracy and subsequently prove good enough to be applicable and useful. ML represents data analytics practices and patterns that teach computers to do what humans and animal perform naturally, such as learn from prior experience, use evidence to inference and abstract. ML models are established by learning directly from the data and in some cases taking input from humans or other machines (ex: supervised learning). Machine Learning uses algorithms to learn from data, perform statistical processing using the data and performs subsequent predictions. Modern implementations of ML develop and harvest ML Models and produce programs that can be implemented and executed as jobs. Jobs will consume data and are implemented on various platforms, such as in-house (“on-premise”) computers and/or on public cloud platforms.

The proposed ML Framework and Patterns are covering key practical elements of applied ML, with focus on simplification, streamlining and making it accessible for everyday practitioner to implement them end-to-end (E2E) and produce practical results. Pattern Recognition (PR) is the process of recognizing patterns by using Machine Learning Algorithms. PR helps detect characteristics of data, including features, classes, clusters and

other properties that yield information about a given system, service or studied entity. Microservices represent engineering patterns to developing applications as a suite of small, independently deployable services built in alignment with key business functions of a solution. Microservices enable simplification and streamlining, while open-source and cloud-native technologies will provide accessibility and ability to implement on-premise and/or public-cloud agnostic. The proposed ML framework includes practices for developing, training and deploying deep learning models as we microservices.

### **CHALLENGES WITH PRACTICAL MACHINE LEARNING**

The multitude of today's machine learning frameworks, together with the broad spectrum of computing platforms and associated technologies for virtualization, computation acceleration and real-time streaming make ML projects implementation very complex and hard to accomplish at scale and as a service. This is made worst by presence of multiple public cloud services providers that use different and many times proprietary technologies that can easily lock in customers and make them cloud and platform dependent. For example, when using Amazon Web Services (AWS) the offered ML solution is based on SageMaker Framework, while within Azure the preferred technology is based on MXNet Framework. Often proprietary technology will lock-in developers and data scientists to sub-optimal and expensive solutions, thus negatively impacting their research and ML implementation efforts.

The challenges this paper addresses are defining simple enough framework with patterns and practices that can be applied for a broad set of problems, leverage multiple open source machine learning technologies, be easy to implement and use anywhere, including developer workstations, on-premise computers and public cloud environment. To achieve this, the patterns and practices must be computation, operating system and cloud-platform agnostic.

### **SOLUTION STRATEGY**

The solution strategy entails researching and developing (R&D) a framework and underpinning patterns that leverage the following elements:

1. REST-based microservices architectures and development patterns
2. Light-weight virtualization components, that implement simplified Software Stack for various ML frameworks, such as Nvidia CUDA Stack for TensorFlow.
3. Cloud agnostic big data components that enable seamless parallel and distributed functionality and scalability
4. Open Source technologies including Big Data, Virtualization and ML Frameworks
5. Cloud Native tools and technologies that enable cloud provider agnostic solutions



6. Opensource workflow type solutions that implement multiple practices end-to-end across ML projects and solutions. Such workflows enable the training, improvement, test, validation and use of ML Models and associated ML Features.

## TECHNOLOGY LANDSCAPE

Let's review the key cloud computing concepts definitions.

**Virtualization** is one of the key technologies for cloud computing, and virtualization in the cloud covers multiple areas:

- Compute: includes virtual machines and other components that use CPUs or GPUs
- Compute acceleration with GPUs; some cloud providers enable GPU virtualization as well.
- Networking, that is required components to communicate. Networking has multiple virtualization implementations, such as VLANs, Overlay Networks, VPCs (virtual private clouds) or VDCs (virtual data centers).
- Virtualized storage attached to virtual machines / compute and unattached storage exposed as API etc.
- Data virtualization and metadata management

**Cloud Computing** is type of shared multi-tenant computing which usually provides remote pool of computing resources and compute services via the internet. The representative cloud compute services are the following:

- Infrastructure as a Service (IaaS), which provides virtualized compute (virtual machines with dedicated operating system), virtualized storage and virtualized network (virtual LANs; VLANs).
- Container as a service (CaaS) also provides virtualized compute which is abstracted away from operating systems using container packaged runtime environment including libraries and applications, Containers don't have dedicated operating system. Containers communicate with the operating systems kernel, as such they inherit a series of process management and security functions
- Function as a Service (FaaS) , which is a lightweight, event-based, asynchronous compute solution that allows creating and running small single-purpose functions that can be instantiated within the cloud without the need to instantiate a server or a runtime environment.
- Jobs (cloud runs) that are stateless containers invoked via HTTPS requests. Jobs can run on top of CaaS or simply abstracted within the provider's cloud environment, such as Google Cloud Run. Sometimes these jobs or runs are called Jobs as a Service (JaaS).

The "**Cloud-Native**" concept emerged within the last 4 years and is characteristic to service or applications that can leverage properties and interfaces offered by cloud computing providers or frameworks, but their code packaging libraries are independent from the cloud provider platforms. Cloud native applications leverage elements from the "The Twelve-Factor App" definitions (<https://12factor.net>) which promotes concepts for optimal design

and deployment in the cloud environment such as declarative formats for setup automation, clean contract with operating system / cloud provider, continuous build and deployment and minimum difference between development and production environments. While many of the concepts of cloud computing implementations are similar, cloud service providers implemented in their cloud environment many proprietary technologies and solution. These proprietary technologies impacted Big Data, Machine Learning, AI, DevOps and other cloud services areas, making very difficult to migrate machine learning applications between cloud providers, as well as between on-premise solutions and cloud providers. The **Cloud Native Computing Foundation** (CNCF) was established as part of the nonprofit Linux Foundation to promote open source software that is cloud agnostic and can be practically deployed to any public cloud of choice without major modifications and re-engineering effort. “CNCF serves as the vendor-neutral home for many of the fastest-growing open source projects, including Kubernetes, Prometheus and Containerd” (cncf.io main page)

**Microservices**, also referred to as Microservice Architecture, represent an architectural style that provides framing for applications as a structured collection of REST-based services, with the following main properties:

- Easy maintainable and testable
- Independently deployable
- Loosely coupled
- Organized around business capabilities and functions
- Owned by small teams

In depth description and references for microservices are available at <https://microservices.io>

## DESIGN PATTERNS AND FRAMEWORK

Design patterns present good practice solutions to frequently occurring problems in Information technology (IT) and Computer Science (CS) solutions design, such as for example object-oriented software patterns, machine learning patterns and others. Their correct application in a solutions design may significantly improve its quality and usability attributes such as ability to reproduce, maintain, scale, accelerate as computation and other attributes. According to Steven Bradley in [1], design patterns, design components, and design frameworks are concepts related to each other. Within this chapter, I will refer to them simply just as patterns, components and frameworks. These three entities help software developers and software engineers developing and implementing modular design, reuse code and machine learning artifacts, implement built-in flexibility and separation of functions or services. Patterns are abstract solutions that have been observed to work for specific tangible problems. They capture common characteristics of similar problems, describe solution elements used, including pros, cons and potential resulting implications. Collecting and organizing representative patterns to a common problem, can lead to a pattern library or pattern catalog. Frequently pattern language and/or component libraries (example stored in Github.com repos) can emerge as well.

Components represent the actual implementations of design patterns. Components provide artifacts, such as code we can reuse in future similar projects. Components should be flexible to enable adoption and adaptation, including patterns-based mechanisms for their modification. There can be multiple components for a single design pattern, as there can be multiple solutions to a problem.

Frameworks combine components, design patterns and package them together following some kind of services-based design, such as Services Oriented Architecture (SOA), Micro Services Architecture or others.

$$\text{Framework} = \sum \text{Components} + \sum \text{Design Patterns}$$

Frameworks support tools and application programming interfaces (APIs) that connect its instantiated components. By nature, frameworks tend to be more specialized.

In general, comparing patterns with frameworks, the following differences can be observed:

- Patterns are more abstract and less specialized than frameworks.
- Patterns represent smaller and more abstracted architectural elements than frameworks.

There are four (4) essential attributes for design patterns, as they emerged over the years:

- Name - defines how we will reference it
- Problem — defines the problem, including context and when the patterns is applicable. It also includes requirements and constraints
- Solution — specifies the elements of the pattern, including their relationships, function, and interactions.
- Implications (consequences) – these result from trade-offs in using this pattern. This is critical for evaluating design alternatives. It is good practice to add here pros and cons as well, which help better describe the implications.

## **ACCELERATING COMPUTATION USING GPUS**

Since the evolution of the Graphical Processing Units (GPU), there were an overwhelming number of studies published about their use to accelerate computation for machine learning and deep learning workloads. Kamil Aida-zade at al. within [3] compared running deep neural networks on GPU and CPU-based frameworks trained using the MNIST dataset. They leveraged CUDA (Compute Unified Device Architecture) parallel computing technology developed by introduced by NVIDIA Inc, which is dominant in the industry using GPUs for computation. The authors clearly demonstrated that GPU based deep learning frameworks are computationally multiple times more effective and faster compared to CPU technology. Youngrang Kim at al. in [4] investigated building Large-scale Deep Learning Framework based on Heterogeneous Multi-GPU Cluster, taking advantage of parallel GPU-based computing using multiple GPU worker nodes. The authors evaluated various distributed

deep-learning scenarios, distributed within a Tensorflow based machine learning framework. The study demonstrated the efficiency of parallelizing workload across four different GPU systems, even when heterogeneous by nature. Eun-Ji Lim et al. in [5] proposed a Shared Memory based framework for Fast Deep Neural Network Training, where multiple deep learning workers shared training parameters (“weights”) using remote shared memory (RSM).

### CONTAINERIZED WORKLOADS FOR MACHINE LEARNING

Pengfei Xu et al. in [6] analyzed the feasibility of running deep learning workloads in Docker containers and performed a series of tests and evaluation regarding tools and technology performance and scalability. The authors concluded that deploying deep learning technology into docker containers is feasible and can benefit overall solution due to its flexibility, lightweight, and resource isolation abilities. Different deep learning software or different versions of the same software can coexist on the same systems yet enabling multi-tenant use and good performance.

Rupesh Raj Karn et al. in [7] has experimented with a Cloud DevOps type solution for ML using containerize infrastructure to enable easy parallelization, on-demand deployment of components and flexible scaling. Their study covered multiple use cases implemented on container scheduler:

- Matching a single optimized model to a given context in a dynamic environment.
- Creating and building multiple models and selecting the best for a given context.
- Closed loop, auto-selection mechanism in the cloud DevOps environment.
- Using unsupervised clustering to segment dataset ahead of supervised classification.
- End-to-end comparison with Ensemble Machine Learning (EML), where different data subsets are drawn from the training set and each training subset is used to train a different classifier.
- DL implementation and its hyperparameters tuning.

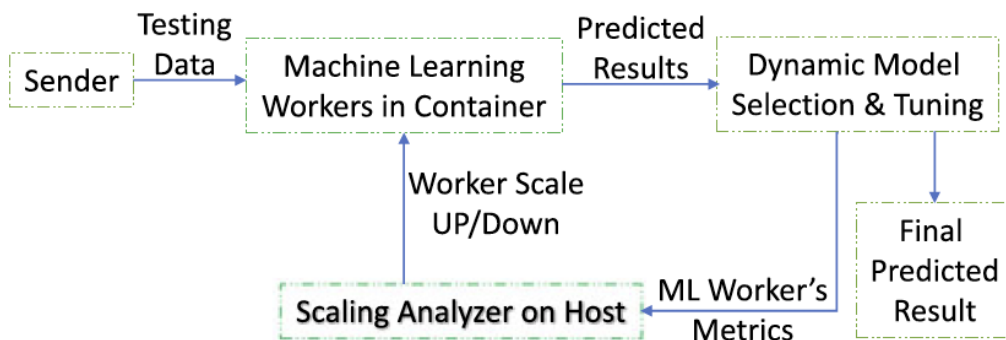

Figure 1. Containerized DevOps architecture for ML.

## **OVERVIEW OF MACHINE LEARNING PRACTICES**

Machine Learning (ML) represents a set of practices and techniques that use algorithms and statistics to learn from data and make predictions that are good enough to be useful. ML enables computers to learn automatically without human intervention and generate outputs or actions based on algorithmic data analysis and inference performed.

Machine Learning algorithms can be categorized as follows:

- Supervised Learning, trains ML model using pre-labeled data, where the correct classes or outcome values are given. The predicted classes or values to be predicted are known and well defined from the beginning.
- Unsupervised machine learning algorithms work use data that is neither classified nor labeled. Unsupervised ML models infer a function to describe a hidden structure from unlabeled data.
- Reinforcement machine learning algorithms interact with its environment to discover errors or rewards and take subsequent actions. Trial and error search and delayed reward are the most relevant characteristics of reinforcement learning. This method allows machines and software agents to automatically determine the ideal behavior within a specific context in order to maximize its performance. Simple reward feedback is required for the agent to learn which action is best; this is known as the reinforcement signal.
- Ensemble learning combines multiple ML models is the process by which multiple algorithms and resulting models, such as classification, prediction, function approximation and others, to solve a particular machine intelligence problem

## **PATTERN RECOGNITION IN CONTEXT OF ML**

Patterns are using Machine Learning algorithm to recognize patterns in the data. It focuses on classifying data based on knowledge already gained or on statistical information extracted from patterns. Pattern recognition discover data arrangements and hidden structures that yield information about a given system or data set.

Pattern recognition algorithms when used in prediction can identify statistically probable movements of time series or other type of data into the future. Their main characteristics are:

- Pattern recognition relies on data to derive outcomes and train models
- Pattern recognition systems must recognize patterns quickly and accurate, as well as classify unfamiliar entities with unknown applicable patterns quickly
- Identify patterns and entities using partially available and/or hidden data.

## MACHINE LEARNING ARCHITECTURE AS MICROSERVICES

Machine Learning solutions incorporate multiple functional building blocks, including data acquisition, data splitting into testing and training datasets, model building, model testing and finally model serving, as presented within the figure below.

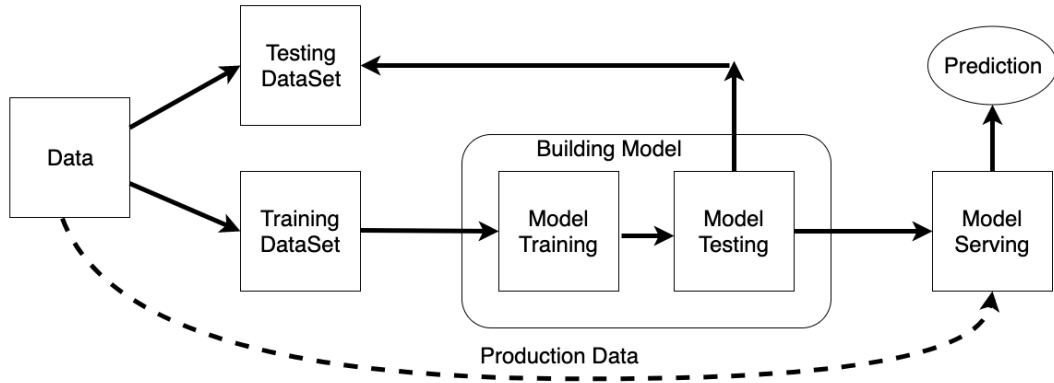

Figure 2. High-level architecture of a machine learning solution.

A Microservices style architecture places functional building blocks of a ML system into individual service components, which can be built, deployed, and scaled individually. Each component implements a standalone machine learning function and is implemented as a distinct virtual infrastructure compute component, such as a container of server-less function. Machine Learning Microservices (MLMs) are small, autonomous services that communicate between each other using REST APIs. The Figure below depicts a conceptual MLM design template for a Machine Learning Project.

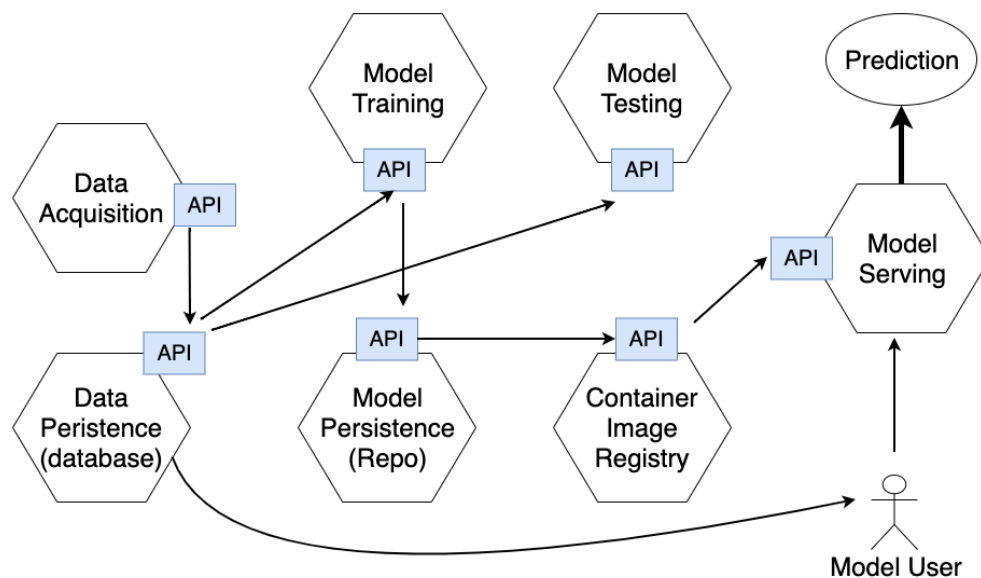

Figure 3. Conceptual MLM design for machine learning projects.

## PROPOSED FRAMEWORK FOR MLM PATTERNS AND PRACTICES

This paper is proposing the following high-level framework for MLM type solutions, which is broken up into three distinct categories of components:

- Data collection and data management components
- ML/DL models training and testing components
- Model serving components

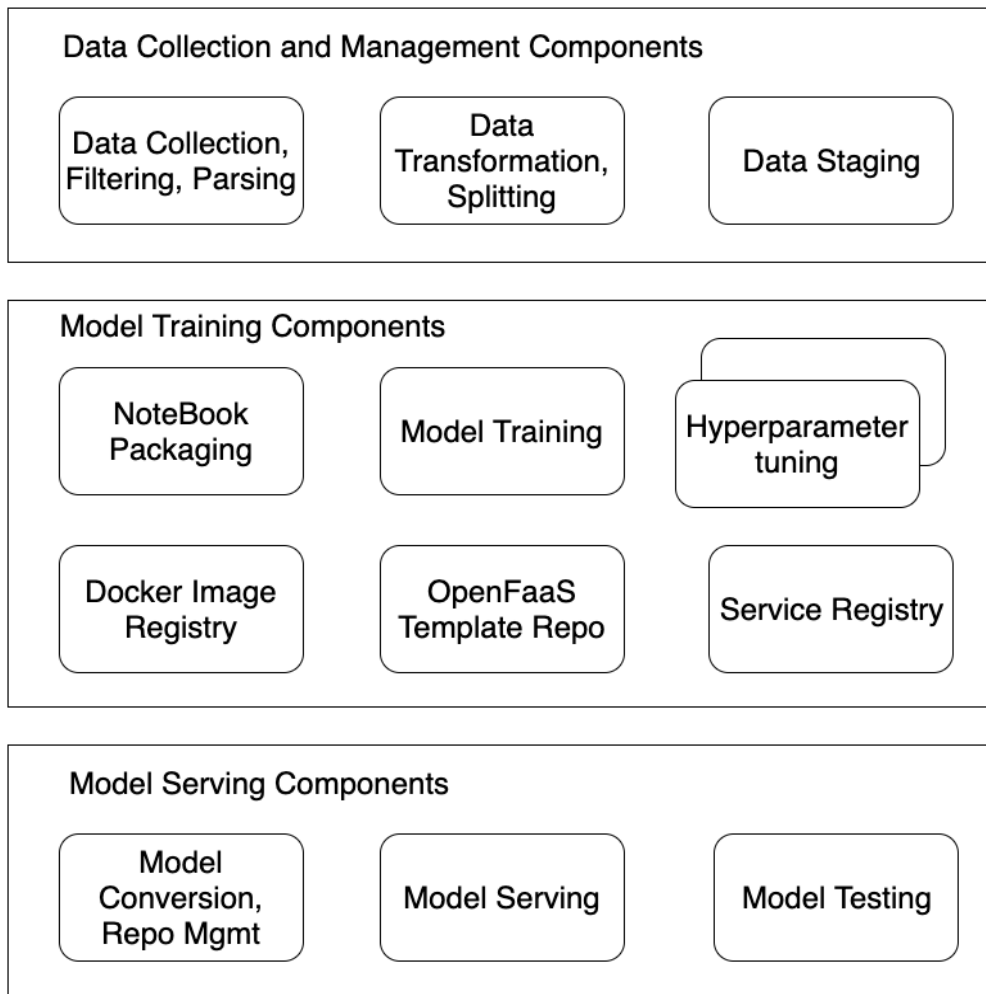

Figure 4. High-Level Architecture ML Components.

A generic architecture for data collection and management components is presented below:

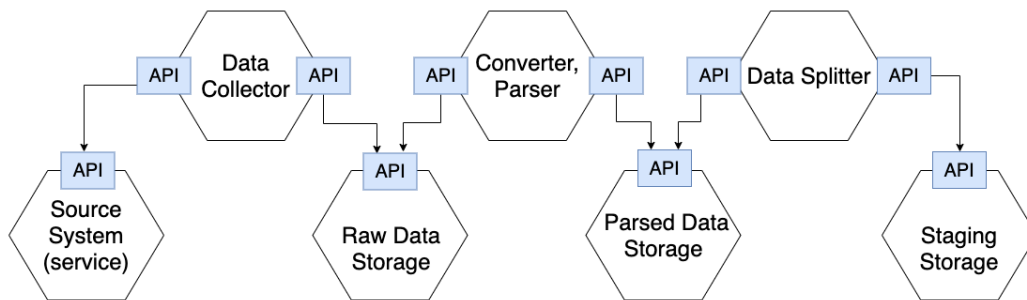

Figure 5. MLM architecture for data processing.

A generic MLM architecture for model training and testing leverages container images, deployable to Docker Swarm or Kubernetes platform. We packaged Talos enabled hyperparameter optimization as microservices, together with Keras, Tensorflow or Pytorch, as well as MongoDB and HDF5Lib containers for models and their weights persistence.

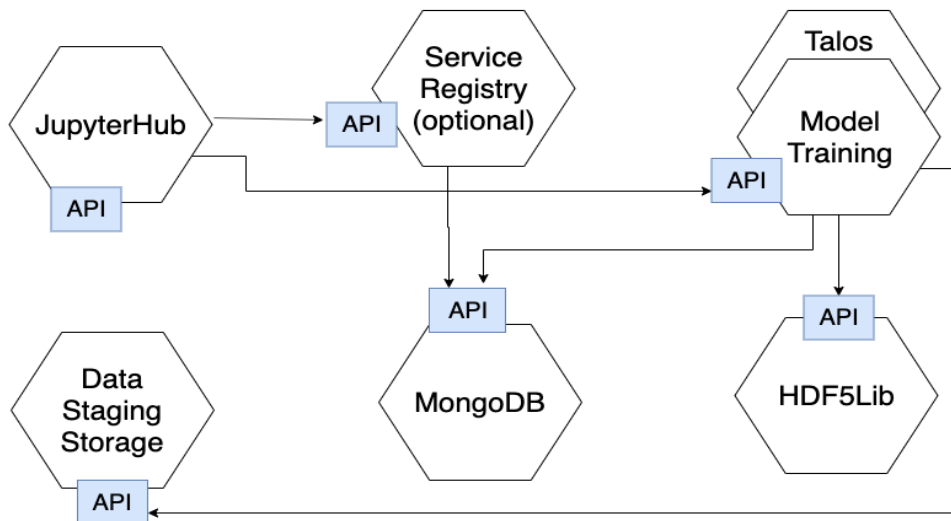

Figure 6. MLM architecture for models training and testing.

Model serving is frequently implemented as a microservice using container type deployment, as well as serverless deployment, publishing the microservice as function as a service (FaaS). We have experimented with serverless infrastructure using the OpenFaaS project ([openfaas.com](https://openfaas.com)) and single node Kubernetes environment ([minikube.sigs.k8s.io](https://minikube.sigs.k8s.io)).



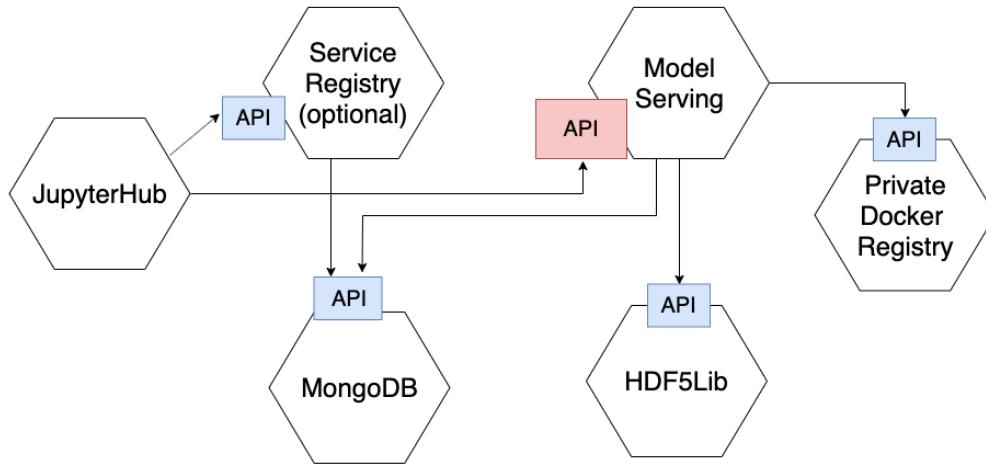

Figure: 7. MLM architecture for model serving.

### ALGORITHMS AND FRAMEWORKS WE USED MLM WITH

We evaluated the MLM concept, including selective implementation and testing for the following ML frameworks:

- SciKit-Learn ([scikit-learn.org](http://scikit-learn.org))
- Keras and Tensorflow ([keras.io](http://keras.io), [tensorflow.org](http://tensorflow.org))
- Rapids-AI project ([rapids.ai](http://rapids.ai)) and its machine learning library CuML ([github.com/rapidsai/cuml](https://github.com/rapidsai/cuml))
- Machine Learning algorithms augmented with Quantum Computing (QML algorithms), such as for example:
  - QSVM from IBM Qiskit SDK ([github.com/qiskit/aqua/algorithms](https://github.com/qiskit/aqua/algorithms)).
  - QKMeans example from <https://github.com/enniogit/Quantum-K-means>

Below are sample supervised learning algorithms considered.

#### **Scikit-Learn: Support Vector Machines**

- Classification: `from sklearn import svm; model = svm.SVC()`
- Regression: `from sklearn import svm; model = svm.SVR()`

#### **Scikit-Learn: Stochastic Gradient Descent**

- Classification: `from sklearn.linear_model import SGDClassifier`
- Regression: `from sklearn.linear_model import SGDRegressor`

#### **Scikit-Learn: Nearest Neighbors**

- Classification: `from sklearn import neighbors; model = neighbors.KNeighborsClassifier()`
- Regression: `from sklearn import neighbors; model = neighbors.KNeighborsRegressor()`

**Keras**

- Classification: `from keras.wrappers.scikit_learn import KerasRegressor`
- Regression: `from keras.wrappers.scikit_learn import KerasRegressor`

**Nvidia: CuML**

- Classification:
  - `from cuml import svm; model = svm.SVC()`
- Regression:
  - `from cuml import LinearRegression`
  - `from cuml import LogisticRegression`

**QML:**

- Classification: `from qiskit.aqua.algorithms import QSVM`

**SAMPLE PATTERN DEFINITION: MLM MODEL TRAINING**

- Pattern Name: “Machine Learning Model Training”
- Pattern ID: MOD-TRAIN-001
- **Also Known As:** “Model training using various frameworks and algorithms as Microservice”
- **Problem** – Implementing machine learning environment SW stack, that integrates with Python libraries, GPU drivers, scales as single or multiple nodes is not a simple task to accomplish. Having all this enabled as a Microservices, that is easy deployable as container or callable as a function makes developers and students life much easier.
- **Purpose (Intent):** Implement a Microservice that takes a generic Python script or Jupyter Notebook and creates a function for it. The function will require as input pointer to training and test data, the loss function and the model name that will be saved and stored. For deep learning models training, may have to specify parameters for defining the neural network.
- **Motivation (Forces):** We need an easy, API based way to train model, available to developers or students with limited knowledge about machine learning and associated tooling.
- **Applicability:** This pattern is applicable for various deep learning networks. Requirements are ability to use various python libraries, input code based on Jupyter notebook or python program, use CPU or GPU based computation. In case of Quantum Neural Networks, the backend would be a Quantum simulator, or an IBM Quantum computer accessed as a Microservices using Qiskit or other Open Source SDK.
- **Structure:** The proposed structure for the Microservice Pattern is based on an initial Jupyter Notebook, that is converted into a microservice. Input parameters must be sent to the notebook, as such as initial step need to parameterize the notebook.

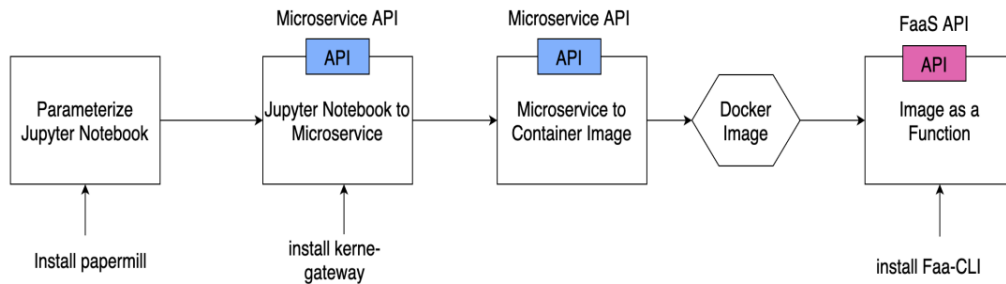

Figure 8. Generic Structure Model Training as a Service.

- **Participants:** The following entities participate within this pattern: Jupyter Notebook, Python Libraries, Papermill product, Github packages (Kernel-Gateway, OpenFaaS), Docker Registry Server: Private Registry or DockerHub.
- **Consequences:**
  - The user will have no direct access to Jupyter; rather via API and sending input parameters
  - Training and Test data must be prepared to Github Repo or some kind of Cloud Storage
- **Implementation (solution, may include diagram):**
  - Pattern deployed as Container; local system or cloud.
  - Pattern deployed as Function; Kubernetes in the cloud.
- **Known Uses:** This pattern can work with multiple machine learning frameworks, Scikit-Learn (extended via MLXtend), Apache Spark, Keras (uses Tensorflow or Pytorch), Nvidia CuML, experimental QML prototypes.

### SAMPLE PATTERN DEFINITION: MLM DATA ACQUISITION

- **Pattern Name:** “Data Acquisition for Machine Learning”
- **Pattern ID:** DATA-AC-001
- **Also Known As:** “Data Acquisition using Open Source Collectors as Microservices”
- **Problem** – There are many different data sources, accessible via different protocols and using multiple authentication mechanisms. Diversified set of data collector capabilities and practices are required to work with these sources of data. Once data is acquired, additional data augmentation is manipulation is required, which should be performed at acquisition stage.
- **Purpose (Intent):** Define simple, easy to deploy, use and scale pattern that can handle most of data collection and processing needs. Data acquisition will have its own mini-framework of connectors (input, out-put, fan-in, fan-out, conditional, etc.) and processors.
- **Motivation (Forces):** Common data Acquisition components and practices are needed to implement this pattern to address broad scale and diversified data acquisition requirements.

- **Applicability:** Applicable to practically all Big Data and traditional relational databases type data sources. It is also applicable to large number of public cloud middleware, such as Google Big Table Aws S3, others.
- **Structure:** The proposed structure for the Data Collector is using one or multiple Microservices. In general, the data collector is deployed as one single microservice (typically as a container), with multiple staging libraries: one staging library for each of the modules within the figure, such as for input, output, processor and others.

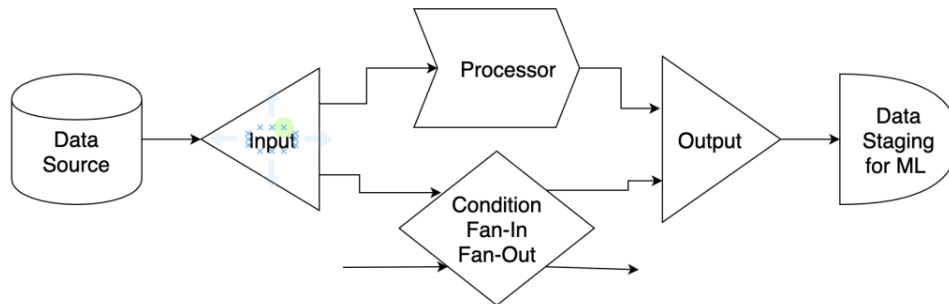

Figure 9. Generic Structure for a Data Collector.

- **Participants:** The following entities participate within this pattern:
  - Data source: Big Data Middleware, remote API, Database, web page, etc.
  - Target staging area, such as for example: Github, filesystem, cloud storage
  - Data collector itself, such as for example Apache NiFi or others
- **Consequences:**
  - Data is acquired and processed by this pattern
  - Proper authentication and authorization required to collect the data
  - Data during transfer will have to be encrypted (encryption in motion)
  - The microservice must be protected, including associated APIs
- **Implementation (solution, may include diagram):**
  - The recommended implementation is using Docker containers, with selectively added staging libraries to the Docker image.
  - The container can be deployed for continuous operation or as a job.
  - Deployment as a function is possible but recommended for simple data acquisition tasks, such as using APIs and with lightweight data processing.
- **Known Uses:** This pattern incorporates several data acquisition and integration use cases. Few examples:
  - Automated data acquisition, parsing, formatting and storage to MySQL.
    - Cloud solution with Google DataFlows.
    - On-premise solution using Apache Nifi.
  - Implementing foreign keys and subsequent joins between multiple data source (MySQL tables).
  - Enrich the data using formulas and new fields.

## REFERENCES

- [1] Design Patterns, Components, And Frameworks by Steven Bradley,  
<https://vanseodesign.com/web-design/patterns-components-frameworks/>
- [2] Essential Framework Design Patterns, Wolfgang Pree
- [3] <http://choices.cs.illinois.edu/uChoices/Papers/fabio/2k/htdocs/Internal/dependence-chapter/related/EssDPs96.ps>
- [4] Comparison of Deep Learning in Neural Networks on CPU and GPU-based frameworks  
Kamil Aida-zade, E. Mustafayev, Samir Rustamov,
- [5] Efficient Large-scale Deep Learning Framework for Heterogeneous Multi-GPU Cluster,  
Youngrang Kim, Hyeonseong Choi, Jaehwan Lee, Jik-Soo Kim, Hyunseung Jei, Hongchan Roh
- [6] Distributed Deep Learning Framework based on Shared Memory for Fast Deep Neural  
Network Training, Eun-Ji Lim, Shin-Young Ahn, Yoo-Mi Park, Wan Choi
- [7] Performance Evaluation of Deep Learning Tools in Docker Containers Pengfei Xu,  
Shaohuai Shi, Xiaowen Chu
- [8] Dynamic Autoselection and Autotuning of Machine Learning Models for Cloud Network  
Analytics, Rupesh Raj Karn , Prabhakar Kudva , and Ibrahim (Abe) M. Elfadel
- [9] Machine learning as a reusable microservice, Marc-Oliver Pahl ; Markus Loipfinger,  
NOMS 2018 - 2018 IEEE/IFIP Network Operations and Management Symposium
- [10] Packaging and Sharing Machine Learning Models via the Acumos AI Open Platform,  
Shuai Zhao ; Manoop Talasila ; Guy Jacobson ; Cristian Borcea ; Syed Anwar Aftab ; John  
F Murray
- [11] A Container Scheduling Strategy Based on Machine Learning in, Microservice  
Architecture, Jingze Lv ; Mingchang Wei ; Yang Yu, 2019 IEEE International Conference  
on Services Computing
- [12] Bodhisattva - Rapid Deployment of AI on Containers, Shreyas S Rao ; Pradyumna S ;  
Subramaniam Kalambur ; Dinkar Sitaram, 2018 IEEE International Conference on Cloud  
Computing in Emerging Markets (CCEM)

## **IMPROVING LOGISTICS PERFORMANCE IN THE DIGITAL ENTERPRISE**

Jose V. Gavidia, School of Business, College of Charleston,  
5 Liberty Street, Charleston, SC 29424, 843-953-6523, gavidiaj@cofc.edu

### **ABSTRACT**

The adoption of artificial intelligence and the availability of real-time data analytics tools is revolutionizing the ERP landscape in an evolution toward the digital enterprise, and this trend will continue for many years to come. This paper analyzes current ERP pain points in logistics, production and supply chain management, including long planning and reaction times due to lack of visibility and analytical tools. The paper then addresses how intelligent ERP systems can address these shortcomings through augmented information via Internet of Things, machine learning and analytical tools that allow detecting problems in real time or even predicting them, proposing optimized solutions, and simulating their outcomes. Specific impact points in logistics are described, contrasting the processes in current versus intelligent ERP.

The sources of advantage of the digital enterprise are derived from the availability of additional sources of structured and unstructured data, faster computing speed allowing the use of advanced algorithms in real time, including artificial intelligence and machine learning tools both inside and outside the ERP system. While enhanced computing speed allows the use of additional deterministic (e.g. material requirements planning) and stochastic (e.g. forecasting) models, artificial intelligence allows the discovery of hidden relationships in the data that can reveal unknown facts both inside and outside the ERP system.

The transition toward the digital enterprise implies an escalation in complexity in ERP systems, with more data and the generalized use of advanced heuristics until now only known in the academic literature. Lack of understanding of these heuristics by implementers or users of the system can lead to errors in configuration and master data which until now have been difficult to detect. These errors include the selection of sub-optimal workflows or models, resulting in decreased logistics performance. The paper will explore how artificial intelligence tools can help to uncover such errors and the impact of the digital enterprise on human skills.

Public comment has been and continues to be an important part of the government rule and policy decision-making process. Often, there is a required period for the public to submit their inputs on proposed policies. This period allows citizen's participation in shaping the policies and rules by submitting written comments that reflect their opinions and views. While the public still has the option to mail in their comments, the preferred method of solicitation and collection of public comments is through an online web form that is primarily unstructured and free-flowing. Although the value of text analysis is its capability to identify patterns and derive structured information from text data, there are increasing challenges in analyzing text data, especially public comments. The criticism of public comments as a means of engaging the public is centered on the high potential for fraudulent and automated system submitted comments. If the utility of public comments will be credible, fraudulent comments and noise in the data must be systematically identified and excluded. This study explored unsupervised sentiment analysis of public comments, identified challenges, and suggested solutions.

We analyzed the public comments submitted for North Carolina's Medicaid Reform Demonstration Amended Application in 2016. The application included requests to implement managed care reform for Medicaid beneficiaries and benefits for sub-group populations. Of the 1997 comments submitted, 44 had no data, 555 were duplicates, one non-English language submission, and 7 with only attached files were excluded. A total of 1,390 comments were analyzed; the length of comments ranged between 3 to 415 words. To identify potential automated submissions, we used these criteria; Cosine similarity score of  $\geq 0.95$ , paired comments with the same length and date, and time of submission within 60 seconds apart. Unsupervised sentiment analysis classified the comments into four categories of sentiment polarity; positive 10%, neutral 5%, negative 34%, neutral 51%. Manual coding of 442 selected comments shows substantial misclassifications because of the nuanced nature of the comments, and the need to address multiple policy objectives in a comment, which may engender contrary sentiments. Three topics were identified in concept analysis; opposition to the proposal, support for the existing Medicaid program, and support for an expansion of Medicaid. Word cloud highlights the keywords associated with each concept.

In conclusion, some public comments are nuanced with mixed opinions that may hinder the identification of clear polar sentiments. Similar comments were submitted multiple times with minor variations, an indication the comments used a similar template. Supervised analysis and trained algorithm may reduce misclassification of sentiments polarity; however, it will require a larger volume of comments. Importantly, a semi-structured format that solicits comments on specific policy objectives rather than a free-flowing unstructured format.

# PERSISTENT HOMOLOGY BASED DATA ANALYTICS: DETECTING ANOMALIES IN ANDROID MALWARE

Paul T. Schrader<sup>1</sup>, Rami M. Alroobi<sup>1</sup> and Md E. Karim<sup>1</sup>

<sup>1</sup>Department of Mathematics and Computer Science, Southern Arkansas University, 100 E. University Street Magnolia, AR 71753-5000  
870-235-*{5121, 4295, 5147}*,*{paulschrader, ramialroobi, mdkarim}*@saumag.edu

## ABSTRACT

We present the preliminary results of a persistent homology application for identifying anomalies in an Android malware dataset. The purpose of this study is not to detect new malwares but to analyze the relationships among reported malwares ultimately assisting analysts to better understand malware trends and develop necessary antidotes. Persistent homology (PH) is a novel data analytics tool that summarizes a dataset using its topological properties which remain stable under small perturbation of the input data. A significant shift in PH output can be attributed to a characteristically significant modification in the input data. PH, therefore, has high potential as an effective anomaly characterization tool, and as such should be explored. Presented results show that while PH indicates the inclusion of a new malware sample in a dataset, determining the nature of the added malware sample (i.e., whether the new sample is a variant or a new species) may not always be conclusive. This finding is explainable since cross-pollination is a common phenomenon that happens during the birth of a malware (e.g., malware authors often borrow code from different existing malware species for use in their own creation). Malware relationships can be characterized more precisely through phylogenetic association. Existing phylogenetic methods use feature-level similarity (or distance) scores to determine malware-to-malware relationships. Preliminary results indicate that PH is a strong candidate for identifying some novel aspects of phylogenetic association. The current study uses low-informative bytecodes as features for their simplicity. Our future PH analytic strategies include semantically enriched higher level features in our follow up study and we expect to see improved results.

## 1 INTRODUCTION

Persistent Homology is a tool of Topological Data Analysis (TDA), a recently developed field originating from applied combinatorics, algebraic topology, and computational geometry. TDA is motivated by the idea that topology and geometry gives us a means to detect qualitative and sometimes quantitative global features of a data set which are stable under small perturbations. The origins of TDA as a field can be traced back to [32] and [105]. The resulting information from TDA provides topological traits of a data set which in conjunction with other standard data analytics (e.g., clustering techniques and uncertainty quantification) yields robust qualitative information. Often the results are presented as visualizations that communicate these features intuitively and aid in inferential or summary strategies.



The engine driving TDA is the field of computational topology. Although various forms of computational topology have utility in TDA the most successful of these approaches is that of persistent homology (PH). PH quantifies critical points of continuous spaces but also addresses more general notions of multi-scale characteristics, high-dimensional features, and abstract data structures with the use of discrete metrics and linearizations. This makes PH an attractive choice for many digital applications where the intuition of TDA has brought numerous results.

Since the beginnings of TDA and PH there have been developments in software which carry out the constructs of a data set's associated complexes, perform the necessary homological computations, produce certain statistical mechanisms of the results, and generate visualizations of PH. Currently, there are several options for the data analyst in this arena. For example, a summary of available TDA and PH software can be found at [68].

The primary objective of this study is to confirm the validity of utilizing PH in detecting anomalies within a specified dataset of software structures, namely Android malware. This application forms a prototype for PH detection capabilities which, in conjunction with standard approaches in data analytics, may enhance our understanding of cybersecurity concerns. Its results strongly indicate the need for further testing of PH and TDA in developing anomaly detection applications.

The structure of the paper is as follows. In section 2 we introduce several different types of common malware (section 2.1) along with some current malware detection approaches (section 2.2) and techniques (2.3). This is followed by a brief overview of malware classification in section 3. Next, we give a short general introduction to TDA and PH in section 4, a short summary of algebraic topology in section 5, and an intuitive introduction to PH in section 6. Section 7 describes the data preparation phase of the experiments in our study, section 8 our experimental design, and section 9 the experimental results. The concluding remarks and future work objectives are in the last section 10.

## 2 ANDROID MALWARE DETECTION

In the last several decades mobile devices have seen a tremendous increase in popularity and use. These, mainly hand-held devices, are equipped with a variety of platforms such as Android, iOS, Windows, etc. In fact, the market share of Android devices is more than 85% during the 4<sup>th</sup> quarter of 2017 (see [43]). However, this popularity of the Android world comes with the price of attracting numerous attackers and malware developers. Since mobile devices became an integral part of many lives these devices contain sensitive personal and financial data; a fortune which malicious attackers are eager to harvest. The goal of anti-malware companies is to protect a users' data. In their ongoing battle new approaches of malware detection and security measures are constantly needed as the attacks become more sophisticated and frequent.

Current anti-malware concerns have objectives which include protecting a users' data and detecting malicious behavior. However, there are different ways for attackers to retaliate such as code obfuscation and stealth techniques, dynamic execution, repackaging, and encryption. Our work focuses on the detection facet of anti-malware strategies. First, before describing Android current malware detection techniques, let us have a quick glimpse of the main flavors

of malwares.

## 2.1 Malware Types

(A) **Trojans:**

Drawing from the Greek idea for using a Trojan horse to gain entrance to the ancient city of Troy, a Trojan is a malicious code that is packaged inside another legitimate software. These malwares can steal information from the infected device such as browsing history, contacts, or financial data. In addition, the Trojan can activate some functions without the consent or knowledge of the owner like sending messages and causing several types of losses. Some examples are [73, 26].

(B) **Worms:**

This type of malware is usually designed to cause congestion problems by creating many copies of itself and distributing those copies through a network connection for various devices (e.g., Bluetooth connections [3]).

(C) **Spyware:**

In this case, the malware app is mainly monitoring the activities of the user to ultimately steal the user's data and send it to the attacker. Also, this type of malware can release a payload that can cause a variety of damage [91, 40].

(D) **Ransomware:**

Here, the damage caused to the device happens by disabling some functionalities until a ransom is paid to the attacker[6]. Often attackers use Cryptocurrency (see [17]) for payment of the ransom making them difficult to track.

(E) **Backdoors:**

This malware type tries to penetrate the attacked device to gain its root privileges. If successful, this will give full control of the device to the malicious attacker. This level of control can lead to stealing user's data and even installing other applications [103].

(F) **Adware:**

An adware is a malware that introduces excessive advertisements frequently trying to lure the user to open them. Once opened the consequences may or may not be harmful but interruption and discomfort have already occurred.

## 2.2 Malware Detection Approaches

According to [55, 8], malware detection techniques can be classified into Dynamic Methods, Static Methods, Honeypots Methods, and Sandboxing Methods.

(A) **Dynamic Methods:**

In this strategy researchers construct their detection techniques by examining the behavior of a live (i.e., active or running) application code. These methods, unlike the static approach, are more effective against variability in malware achieved by means of code obfuscation, encryption, repackaging, etc. In this case usually machine learning

techniques are used to detect abnormal behavior of the apps (or applications) running on the device. The malicious behavior can render itself in the form of certain system calls, CPU consumption, battery consumption, and network communications. These features are then often used to classify apps as malware or not. Other techniques only monitor the use of sensitive resources like camera input (see [96, 36]).

(B) **Static Methods:**

Contrary to dynamic methods, static methods study the behavior of the source code before execution occurs (i.e., resting code). The types of static methods are code signature based, resource permission based, and bytecode based. Code signature based methods are very common in commercial Anti-Malware tools. This approach extracts the semantic features of the code and creates a signature from those features. Examples of semantics include methods names, control of flow, etc. (see [41]). Some other approaches detect malware using code signature (see [37, 99]). In these cases the signatures have to be known. The resource permission based methods analyze certain permission xml files, such as `AndroidManifest.xml`, where resource permissions are stored on the android system. This method checks for apps that have requested resource access permissions which exceed expected use (see [84, 52, 79, 53]). According to [61] malware apps request 12.99 permissions on average while benign apps requested 4.5. Another approach is Intent analysis [92] where *intents* are objects with data about the operations to be performed. Finally, there are bytecode based methods. Their objective is to obfuscate the original bytecode of the app and transform it to a different bytecode that can be analyzed in terms of method calls, control, and data flows. For example, methods such as [42, 100, 24, 57] use bytecode analysis for malware detection. Another example uses *dex code* which is unique for Android systems and can be found in files such as `classes.dex` in the android apk. The dex code can be decompiled into different formats with several levels of granularity ranging from bytecode, to assembly, and readable source code. Some formats and approaches along with their corresponding results include: Dalvik Bytecode [58] with results of  $\simeq 75\%$  unknown, Java bytecode [23] with results of false positive  $\simeq 12.5\%$ , source code [29] with results of accuracy  $\simeq 94\%$ , Smali [50] with results of accuracy  $\simeq 99\%$ , Assembly [39] with the results of false positive  $\simeq 4\%$ , Jar [46] with results of false positive  $\simeq 35\%$ , and Jimple [9] with recall  $\simeq 93\%$  and precision  $\simeq 86\%$ .

(C) **Hybrid Methods:**

This approach applies static and dynamic methods to enhance the detection process. In [16], the process starts with static analysis of the code. Then dynamic analysis of the system calls off the executed code into a sandbox. Another approach, in [97] and [62], statically analyzes activity paths in the code and use these results during the dynamic analysis of code execution.

(D) **Honeypot Methods:**

This approach purposefully plans to attract attacks from malware developers by creating groups of honeypots (e.g., an outdated API or Application Programming Interface with security flaws). In this way, the behavior, techniques, and technologies used by malicious attacker can be analyzed and studied (see [80]). However, managing and

protecting honeypots can be an exhaustive task specially when the complexity of these pots increases.

(E) **Sandboxing Methods:**

The use of sandboxed environments results in more freedom to test and manipulate malware apps in isolation (see [85]). In this case numerous experiments can be applied without the concern of infecting other platforms or devices. A sandbox is a special case of the more general solution using virtual machines that can be employed to test the execution of the malware apps [74]. The difference between real platforms and sandboxes can be a limiting factor in these approaches.

## 2.3 Malware Detection Techniques

In this section we overview some of the specific methods the aforementioned approaches to detect malware apps (see [83]).

(A) **Network Traffic Analysis:**

Monitoring network activity can be indicative of benign or malware activities. In [78] it was reported that 93.38% of malware apps tried to access network resources while only 68% of benign apps requested to access the network. Accessing the network can lead to downloading malicious payloads or loss of a user's data. In this case, packet analysis and port scanning can be part of this analysis process.

(B) **Analysis of Application Programming Interfaces:**

API (Application Programming Interfaces) provide a set of functions for apps to access the services of another entity (the mobile device in this case). The APIs include the app libraries and the system APIs. In [98, 93] the researchers tried to use dynamic analysis to monitor system APIs to check for app policy enforcement.

(C) **Tracking System Calls:**

For any app to access the device hardware resources it must use/invoke system calls. Usually the process entails switching from user mode to kernel mode where the system calls can be performed. Analysis of system calls behavior has been part of the work in [47, 75].

(D) **Creating Dependency Graphs:**

In this method the app is represented as a graph where statements are nodes and edges based on statements to statement dependencies for their values or for their execution. These graphs can be used to track data flow so losses can be identified (see [102, 4, 10]).

(E) **Extracting Features:**

From a certain perspective an app can be considered as a set of features (such as APIs) that are triggered during the app execution in the dynamic analysis. Studying such features can highlight the behavior of the app as malware or benign (see [11, 27]).

(F) **Monitoring Function Calls :**

The dynamic monitoring of function calls while running the app aids in the creation

of a semantic overview for the app and confirms if the functions have experienced any misuse. Usually, a function can be hooked and triggered to allow for parameter analysis.

(G) **Following the Flow of Information:**

An important aspect for malware detection is the ability to follow the data flow and create data flow graphs. The path of the data from the source to the sink can exhibit data loss (see [36, 46]). The flow analysis can be employed to track app level messages and virtual memory variables. Machine learning approaches (see [72]) can use features like API usage, code syntax, and code semantics to provide more information about the source and sink of data flow.

(H) **Tracking the Inter-Process Communication Analysis:**

In any operating system such as the Android, the performance of the system depends on process interactions in the form of inter-process communications (IPC). In addition, processes can invoke objects and services which are remotely located using remote procedure calls (RPC) as if these were local to the residing system of the process. The analysis of IPC/RPC can provide insight on malicious activities about attempts to access suspicious web resources or if some applications are participating in an orchestrated behavior. Some methods use static approaches to track the movements of *Intents* (see [60, 95]).

(I) **Hardware Activity Analysis:**

Hardware monitoring can be an essential part of malware detection. For example, monitoring a device's power signature, power consumption, and CPU cycles may indicate malicious activity. For example, in [5], the method collects data from different hardware components, use these as features, use machine learning to train the system and create models, and lastly use those to detect malware.

### 3 MALWARE CLASSIFICATION

Developing automatic approaches to classify malware apps is becoming a vital need with significant challenges such as evasion detection which uses more sophisticated obfuscation techniques. In the context of dynamic analysis, some approaches have been developed to classify malware tracking through the use of system calls (see [12, 14]). Although successful, these approaches have serious limitations such as operating system specificity (i.e., system calls differ from one system to another), random system calls execution, etc. According to [83], one way to address issues similar to these is to consider a behavior-oriented analysis that can be based on system calls among other features. The behavior features are based on effects of the system calls such as file changes, network connections, and changing of system settings. In CopperDroid [83], another method reconstructs system behaviors such as SMS send, IMEI access, and Intent communications by tracking detailed system calls traces. These behaviors are fed into a hybrid machine learning system that combines the Support Vector Machine (SVM) classifier and the Conformal Prediction (CP) classifier. SVM

works to categorize the data based on data labels by a separating hyperplan, which could be a line if the data has only two classes [25]. SVM achieved accuracy ranging from 75% to 94.5%. For app samples that were not classified successfully CP was used to improve the performance of the method. In this study they used a dataset of 1,137 samples from the Android Malware Genome project (see[101]).

In [12], the method used compression distances to measure malware sample similarity and used hierarchical clustering on the malware samples. Out of 3698 samples this method achieved success rate of 91.6%.

Still another method in [76] uses SVM for classifying and clustering malware samples. The behavioral features are employed and their frequencies were embedded into a vector space. These vectors were used to train the SVM classifier. 3,139 samples were considered and the method correctly identified 70% of the samples.

In [94], the method creates a behavioral graph that is created statically to detect malicious behaviors. The nodes of the graph are sensitive API calls. All the paths between those sensitive nodes are analyzed to detect and classify malware apps using a random forest tree classifier. Out of 12,466 apps the approach correctly classified 95.3% of the apps.

For the method described in [4], a context dependency graph was created from statically extracted APIs to create app semantics. One graph of the database was created for malware apps and another graph for benign ones. Graph based features were extracted and used to train two classifiers. Then Graph weights were introduced to distance malware from benign datasets. Against 2,000 malware samples and 13,000 benign samples the method accuracy rate was 93% for multi-classification and it was also successful in detecting zero-day malwares. As has been the case, statically based methods are limited against native code and embedded malicious code.

In [28], the method uses API signatures to classify malware families . The signature is commonly a digest of the API code. The digest can be created by employing one of several hashing functions such as SHA-1 or MD5 (see [30, 77]). To extract the signatures, the Android Package (APK) of the app is partitioned into modules and those modules are then analyzed to find modules with higher probability of being malicious. The accuracy achieved in this method was  $\simeq 94\%$ . However this approach, being a static method, has weaknesses regarding dynamic code behavior.

The method in [95] focused on the context (i.e. environment) where the malicious app shows behavior. The method uses a set of features such as permissions, hardware, and user interface. The context is created through tracking the inter-component communications activity. In this study, features from 200 malware apps and 633 apps from Google play were used in the analysis involving an SVM classifier. The precision was around 89.7%.

In [7], the features from the apps samples are extracted based on permission from the android manifest and decompiled APK codes like APIs and network addresses among others. These features are used to create a boolean vector with 0 and 1 representing the existence and absence of the feature respectively. This process is performed for malware and benign apps and both vectors are used with an SVM classifier. With 100,000 benign samples and 5,000 malware samples, the accuracy rate was 94%.

Additionally, neural networks are being deployed in malware detection. In [64], they used convolutional neural networks (CNN) which have been successful in natural language processing to classify malware data. Here the disassembled malware bytecode is treated as

text to be analyzed by the CNN. The approach is n-gram, which are symbolic pattern based, where the features used to train the classifier are low-level opcodes. An app APK has dex code files, xml file, and resources files. The dex files can be transformed into smali files. A smali file is one class, each of these classes has methods, each method has instructions, and an instruction has an opcode; these opcodes are the only features considered. In this case, manual intervention is not necessary. The datasets in this study were obtained from the Android Malware Genome project (see [101]) and McAfee Labs ranging from  $\simeq 2,000$  to  $\simeq 18,000$  apps that are benign and malware. The performance of the method was efficient after training the CNN was done classifying 3000 malware per second. The accuracy ranged from 82% to 98%.

## 4 A BRIEF INTRODUCTION TO TOPOLOGICAL DATA ANALYTICS AND PERSISTENT HOMOLOGY

A recent field originating from studies in applied combinatorial and algebraic topology along with computational geometry is called Topological Data Analysis (TDA). TDA is motivated by the idea that topology and geometry gives us a way to expose qualitative and sometimes quantitative global features of a data set which are stable under small perturbations. Its objective is to supply rigorous mathematical, statistical, and efficient algorithmic methods that produce meaningful analytics when applied to topological and geometric structures of significant complexity which represent an underlying data set. Often these data sets are point clouds embedded in Euclidean or some more general metric space where a notion of distance is defined. The genesis of TDA as a field can be traced back to [32] and [105]. TDA became more widely known after the introduction of [19]. For some further references on TDA see [104], [21], and [71].

Under the assumption that the input is a finite point cloud of data (which may be high-dimensional, noisy, and dynamic) embedded in a metric space, TDA follows a typical flow of topological constructions and analytical steps. First a combinatorially continuous space, usually in the form of a simplicial complex, is built from the data which act as its vertices. Roughly, a simplicial complex, say in  $\mathbb{R}^n$ , is a finite set of simplices (points, line segments, triangles, tetrahedra, and their  $n$ -dimensional counterparts) which are disjoint or intersect in a particular way (see section 5 for details). This complex emphasizes the underlying topology or geometry of the given data while portraying at its differing scales and dimensions. Then topological or geometric information is produced about the complex using particular computational methods derived from algebraic topology (e.g., persistent homology). The resulting information provides global topological features which in conjunction with other standard data analytics (e.g., clustering techniques and inferential strategies) yields robust qualitative information about the data set. Often the results are presented as visualizations that communicate these features intuitively and aid in summary strategies.

The power plant which drives TDA is the field of computational topology. Although various forms of computational topology have utility in TDA (e.g., see [34], [54], and [106]) the workhorse and most successful of these approaches is that of persistent homology (PH). The mathematical foundations of PH lie in Morse theory (see [65]). Not unlike Morse

theory, PH quantifies critical points of continuous spaces but also addresses more general notions of multi-scale characteristics, high-dimensional features, and abstract data structures with the use of discrete metrics and linearizations. This makes PH an attractive choice for many digital applications where the intuition of TDA has brought numerous results. Some examples of the successful implementation of PH can be found in [15], [38], [48], [82], [88], [87], [51], and [59].

## 5 A BRIEF OVERVIEW OF ALGEBRAIC TOPOLOGY

The goal of this section is not to provide a comprehensive discussion of the known results of algebraic and point-set topology. Here we briefly outline the required background to intuitively understand PH in section 6 and its applications to malware later in the paper. However, for the reader interested in pursuing this well-understood mathematical subject we do provide suitable references throughout this section.

To understand the notions of TDA and PH one must first understand the subject of topology. Topology is the mathematical study of abstract spaces and the continuous transformations (or deformations) between them. More precisely, a *topological space* is a set  $X$  together with a collection of all subsets in  $X$  defined as “open” or necessarily satisfying a list of set theoretic properties. A metric or notion of distance is permissible but not required. Networks, data sets, signals, imagery, graphs, vector spaces and Euclidean space are all familiar examples of topological spaces. The inclusion of a vector subspace in a vector space is a relevant example of a continuous transformation (or *function*) between topological spaces.

Topology is concerned with the fundamental notion of equivalence up to a defined “flexible nearness” of what makes a space (i.e., *homotopic* and *homeomorphic* equivalence). Thus, properties of a space such as connectivity and holes are significant while the bends and corners of a space are of less importance. *Topological invariants* of spaces and the continuous mappings between them record essential qualitative features insensitive to coordinates changes and deformations while providing the assembly instructions for the space. The reader can find a detailed study of point-set topology in [67].

Eponymous in nature, *algebraic topology* provides information about a topological space through algebraic methodologies. *Homology* is a mature compression schematic in algebraic topology that can measure important topological features of a space such as connected components, holes, and voids (e.g., the interior of a surface, such as a sphere, embedded in 3 dimensional space). Homology intuitively associates to any topological spaces  $X$  a family of groups which encode topological features of  $X$  at particular dimensions. These groups are known as *homology groups*  $H_k(X)$  where  $k = 0, 1, \dots$  represents the particular dimensions of the encoded topological features of  $X$ . For example, the *0th homology group*  $H_0(X)$  detects the connected components of  $X$ , the *1st homology group*  $H_1(X)$  detects the holes of  $X$ , the *2nd homology group*  $H_2(X)$  detects the voids in  $X$ , etc. A fundamental property of homology is that any continuous function between topological spaces (e.g., vector spaces)  $f : X \rightarrow Y$  ( $T : V \rightarrow W$ ) induces a homomorphism (linear transformation)  $f_* : H_k(X) \rightarrow H_k(Y)$  ( $T_* : H_k(V) \rightarrow H_k(W)$ ) between homology groups (matrix representations) encoding how  $f$  ( $T$ ) maps topological features from  $X(V)$  to  $Y(W)$ . In fact, a



mapping between homeomorphic topological spaces (or a *homeomorphism*) induces an isomorphism between their respective homology groups. Furthermore, aside from encoding and characterizing topological properties of complex structures, homology remains robust under small perturbations. These qualities make homology an attractive choice for data analysis especially when considering linear spaces which can represent most data sets (homogeneous, dynamic, high-dimensional, or otherwise). One can find further details of algebraic topology and homology in, for example, [35], [66], [49], and in the second part of [67].

The types of topological spaces we work with here in our homological computations are linear and known as simplicial complexes. Intuitively, a simplicial complex is constructed from a union of points, edges, triangles, tetrahedra, and higher dimensional polytopes connected in a specified way. Thus, they can be viewed as higher dimensional generalizations of graphs. More precisely, given a set of points  $V = \{v_0, \dots, v_k\} \subset \mathbb{R}^n$  (finite dimensional Euclidean space) of  $k + 1$  affinely independent points (i.e.,  $v_1 - v_0, v_2 - v_0, \dots, v_k - v_0$  are linearly independent), a  $k$ -dimensional simplex  $\sigma = [v_0, \dots, v_k]$  spanned by  $V$  is the smallest convex set (or convex hull) of  $V$ . We call the points of  $V$  the *vertices* of  $\sigma$  and the simplices of  $V$  spanned by the subsets of  $V$  the *faces* of  $\sigma$ . A *geometric simplicial complex*  $S$  in  $\mathbb{R}^n$  is a collection of simplices such that any face of a simplex in  $S$  is a simplex of  $S$  and any intersection of two simplices in  $S$  is either empty or a common face of both. For example, a set of data points  $X_0$  in  $\mathbb{R}^n$  could be viewed as a simplicial complex contained in the graph  $X_1$  (also a simplicial complex) whose vertex set is  $X_0$ . Furthermore, 0-simplices are the vertices of this graph and 1-simplices are the edges of this graph whose faces are the 0-simplices. Higher dimensional simplices include 2-simplices (triangles), 3-simplices (tetrahedra), etc. We call an indexed sequence of nested simplicial complexes a *simplicial filtration* or simply a *filtration*. For further details on simplicial complexes see [66], [49], and [54].

Assuming that the given data set is embedded in a topological space equipped with a notion of distance or a *metric space* (like  $\mathbb{R}^n$ ) there are several ways to construct simplicial complexes from a given data set. Our strategy in this study assumes that  $X = \text{AMD}$  (i.e., the Android Malware Dataset found in [89]; for more details see section 7) is a point cloud (or set) in finite dimensional Euclidean space making  $X$  a metric space with Euclidean metric  $d_X$ . Then by choosing a real number  $\epsilon \geq 0$  we construct a simplicial complex based on  $X$  called an *Vietoris-Rips complex* or  $\text{Rips}(X, \epsilon)$ . A  $\text{Rips}(X, \epsilon)$  is a simplicial complex whose vertices are the points of  $X$  and  $\sigma = [x_0, \dots, x_k] \in \text{Rips}(X, \epsilon)$  if and only if  $d_X(x_i, x_j) \leq \epsilon$  for any  $i, j \in \{0, \dots, k\}$ . Further details on these types of simplicial complexes can be found in [86]. The reader can find details of simplicial complex constructions in, e.g., [22] [31], [33], [34], and [32].

Figure 1 provides an example of an  $\text{Rips}(X, 2\epsilon)$  formed from a point cloud in  $\mathbb{R}^2$ . Beginning in part (a) of Figure 1 with our point cloud  $X$  we then choose a real value  $\epsilon \geq 0$ . In part (b) of the same figure we develop open disks whose radius is the chosen  $\epsilon$  and whose centers are the points of (a). Although not necessary the visualization involving the construction of these disks is often done for the viewer's convenience in realizing the complex. Then, based on the definition of  $\text{Rips}(X, 2\epsilon)$ , in part (c) we construct the associated simplicial complex. So if any two vertices (or 0-simplices) are less than or equal to  $2\epsilon$  apart then an edge (or 1-simplex) is drawn between them. Similarly, if three vertices are less than or equal to  $2\epsilon$  apart then a 2-simplex is constructed between their shared edges, if four vertices are less than or equal to  $2\epsilon$  apart then a 3-simplex is constructed between their shared triangular

faces, etc.

A key feature to the effective use of simplicial constructions such as  $\text{Rips}(X, \epsilon)$  in persistent homology is not to consider a single real value for  $\epsilon$  but to let  $\epsilon$  continuously dilate toward an arbitrarily large value. In effect, this causes the evolution of a Rips complex based on a vertex set whose elements are a data set of interest. We see this evolution occur in Figure 2. As  $\epsilon$  continuously increases in positive value (as indicated by the dilation of the disks) then a sequence of nested simplicial complexes (in particular Rips complexes) are formed. It is on these types of simplicial filtrations we perform our persistent homological computations yielding global topological information about connected components, holes, and voids that mirror the topological information about the underlying data set.

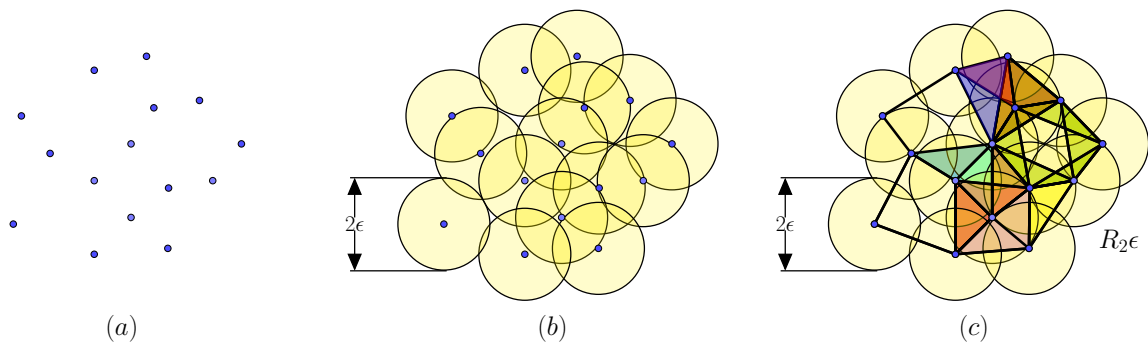

Figure 1: The Construction of a  $\text{Rips}(X, 2\epsilon)$  complex from a point cloud in  $\mathbb{R}^2$

## 6 PERSISTENT HOMOLOGY

For those new to PH we suggest [45] and [44] and for the non-mathematician [69]. More advanced literature on the subject of PH can be found in, for example, [22], [13], [20], [34], [31], [33], [63], and [70]. The following section is drawn from these references and are known results.

The notion of PH provides a mathematical structure containing coherent algorithms which encodes the developing homology for families of filtered topological spaces indexed by a set of real numbers. Often these indices are seen as scales as in our case when applied to the evolution of a Rips complex. So given a filtration  $\{R_\epsilon\}_{\epsilon \in \mathbb{R}_{\geq 0}}$  based an evolution of a Rips Complex based on a data set of interest in  $\mathbb{R}^n$  its homology changes as  $\epsilon$  increases: new connected components can appear and existing connected components aggregate, holes and voids can form and be filled, etc. PH gives us a means to monitor and record these changes by identifying features (i.e., connected components, holes, and voids) on by an interval representing lifespan or  $(\epsilon_{\text{birth}}, \epsilon_{\text{death}})$ . For example, a connected component is a feature that is *born* in a filtration  $\{R_\epsilon\}_{\epsilon \in \mathbb{R}_{\geq 0}}$  at the smallest such  $\epsilon_B$  that the component is present. When that connected component merges with an older connected component at  $\epsilon_D$  then it is said to *die*. Holes and voids are detected and given a lifespan by PH using the same information. These *birth/death pairs*  $(\epsilon_B, \epsilon_D)$  completely describe the topological features and their significance in the filtration. The longer a feature persists the more relevant it is in describing the topology of the filtration and the underlying data set. One can consider

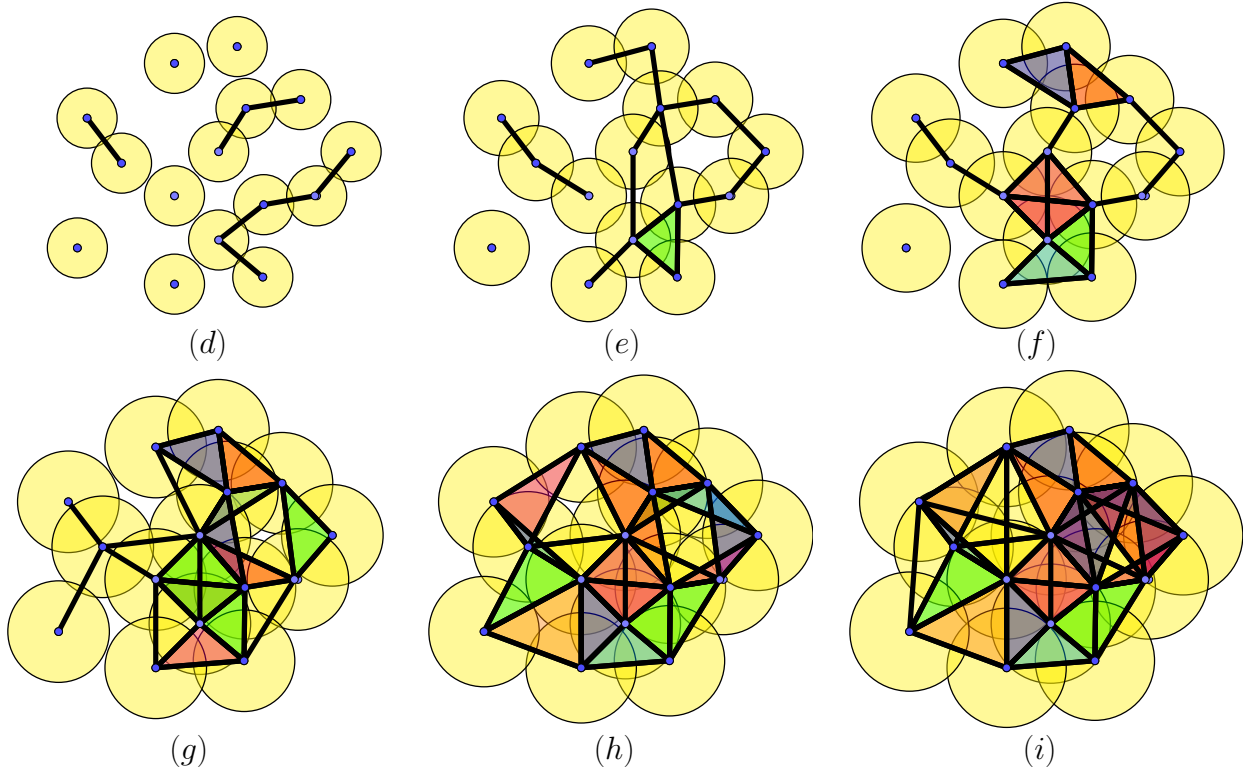

Figure 2: The Evolution of a Rips Complex based on a point cloud in  $\mathbb{R}^2$

the birth/death pairs  $(\epsilon_B, \epsilon_D)$  as order pairs in  $\mathbb{R}^2$ . This set points is called the *persistence diagram* of the filtration. Alternatively, the collection of intervals representing the lifespans of these detected features is called a *barcode* of the filtration.

A third way to represent the PH on a filtration  $\{R_\epsilon\}_{\epsilon \in \mathbb{R}_{\geq 0}}$  is called a persistence landscape. First seen in [18] the following definitions and results are taken from there. Given a birth/death pair  $(b, d)$ , we first define the piecewise linear function  $f_{(b,d)} : \mathbb{R} \rightarrow [0, \infty]$  by

$$f_{(\epsilon_b, \epsilon_d)} = \begin{cases} 0 & \text{if } x \notin (b, d) \\ x - b & \text{if } x \in \left(b, \frac{b+d}{2}\right] \\ -x + d & \text{if } x \in \left(\frac{b+d}{2}, d\right) \end{cases} \quad (1)$$

The *persistence landscape* on the birth/death pairs  $\{(b_i, d_i)\}_{i=1}^n$  is the sequence of function  $\ell_k : \mathbb{R} \rightarrow [0, \infty]$  with  $k = 1, 2, \dots$  where  $\ell_k(x)$  is the  $k$ th largest value of  $\{f_{(b_i, d_i)}(x)\}_{i=1}^n$ . Here we set  $\ell_k(x) = 0$  if the  $k$ th largest value does not exist so that  $\ell_k = 0$  for  $k > n$ .

An example of a persistent diagram (PD), a barcode (BC), and a persistent landscape (PL) taken from our experimental results presented later in section 9 is seen in Figure 3. In this case, we perform PH on a particular variety of Android malware; the LotoorV14 data set reduced under PCA from 256 features (dimensions) to 70 features (dimensions). To begin, we construct an evolving Rips complex using the PCA70LotoorV14 data forming

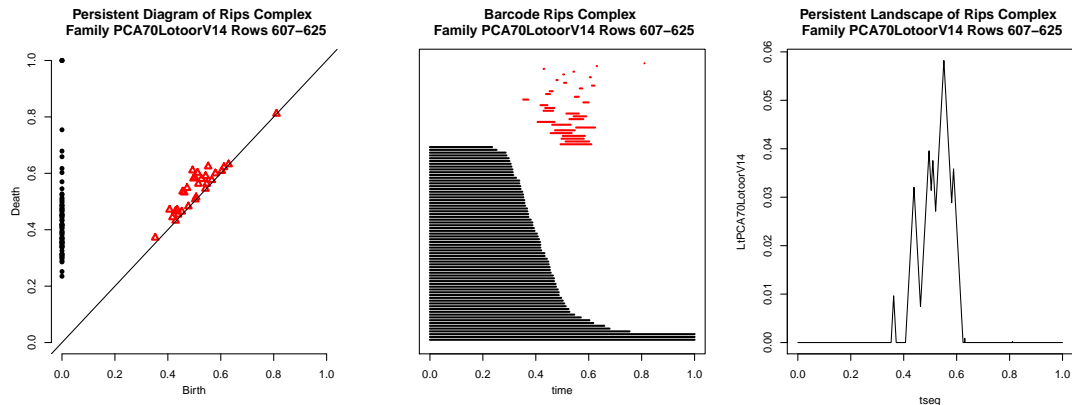

Figure 3: An Example of a persistent diagram, barcode, and persistent landscape of a filtration

a filtration and performed the PH computations on this filtration. All computations were done in the TDA package of R. For each diagram our we limit our PH computation to the 0th and 1st homology groups encoding the connected components and holes respectively of the filtration. This amount of information is sufficient for detection and identification within our study and reduced computational expense in the PH. However, if the need arises, the TDA package can be programmed to perform PH in any finite dimension.

Beginning the PD, where the birth/death pairs are taken as ordered pairs in  $\mathbb{R}^2$ , observe that the horizontal axis is associated to the birth values and the vertical axis to the death values. The black points in the PD indicate the birth/death pairs for connected components in the filtration associated to the data set PCA70LotoorV14 and the red triangles represent the birth/death pair for a hole. All birth/death pairs in a PD will lie on or above the diagonal since a feature cannot die before it is born. Since this filtration is based on an evolving Rips complex on the PCA70LotoorV14 data set the topological features encoded in the PH on the PD are topologically equivalent (in particular, homotopy equivalent) to the topological features of the PCA70LotoorV14 data set. Thus, the set of all birth/death pairs from the PH computation of the PCA70LotoorV14 filtration visualized in a PD gives us a potential method to distinguish this malware type's data set from others. Moreover, this method should detect anomalies within this data set due to the change in topological features encoded in the PH computations.

Recall that in a BC the birth/death pairs  $(\epsilon_{\text{birth}}, \epsilon_{\text{death}})$  are taken as intervals in  $\mathbb{R}_{\geq 0}$ . In the middle graph the BC considers these as time intervals where the time  $t$  runs along the horizontal axis. The black intervals represent connected components and the red intervals the holes. As our  $\epsilon \geq 0$  dilates and the Rips complex evolves the individual bars in the graph indicate the lifespan of particular topological features starting from  $t = 0$ . For example, at  $t = 0$  we have all distinct connected components in the filtration from the PCA70LotoorV14 data set since  $\epsilon = 0$ . As  $\epsilon > 0$  over time, some of these distinct connected components merge and begin to die off. This begins to occur in  $0.2 < t < 0.4$  and continues until a single connected component exists as  $t \rightarrow \infty$ . Also, as some connected components merge they

may form cycles which bound holes. The red bars above the black bars in the BC track these hole lifespans. As with the PD, the BC can also give us a second potential method to distinguish a malware type's data set from others and detect anomalies within this data set.

The PL in Figure 3 is formed by evaluating the set of all birth/death pairs from the PH computation on the filtration based on PCA70LotoorV14 (i.e., the Principal Component Analysis on variety 14 of the HackerTool family "Lotoor" of [89]; see Figure 5) in the equation 1. This inherently piece-wise linear diagram is the most intuitive way to identify and distinguish this malware type data set. In their PL each distinct malware type, family, and variety would produce a distinct PL due to the differences in topological features of their filtrations yielding a third potential detection method for anomalies.

## 7 DATA SOURCE AND PREPARATION FOR THE PH ANALYSIS

In [89], malware datasets were collected and grouped into families. Family names were given based on information related to the malware samples such as malware writer, campaigns, keywords, and other characteristics.

The malware apps were collected from VirusShare [1], Google Play, and other security companies. VirusTotal [2] is a well-known service to submit suspicious files and URLs for malware detection and can be used for assigning family names, based on commercial anti-virus (AV) tools analysis. However, a lot of acquired apps did not have a family. Therefore, similar to [81], a process of two steps was employed: 1) VirusTotal decided if the app is malware or not based on 50% voting threshold among the AV tools. 2) The dominant-key-word search for dominant keywords generated by VirusTotal was used along with the manual removal of generic English words. The resulting keyword (i.e., the family name) has to appear in 50% of the results and it has to be at least twice any other keyword. In this manual process other tools were employed (see [90]) to track API calls. Some IDE tools were also part of the work to illustrate class hierarchy, def-use chains, and method invocation. Since the analysis is mainly manual, no accuracy rates were reported. Data preparation section has further information about the dataset resulting from this work.

The work of this paper is based on the Android Malware Dataset (AMD) (see [89]). The Dataset has 71 Malware families that are divided into 135 varieties. The total number of samples considered in the study is 24553. The families belong to different Malware types such as Adware, Backdoor, Ransom, Trojan-Banker, Trojan-Dropper, Trojan-SMS, Trojan, Trojan-Spy, Trojan-clicker, and HackerTool. Figure 4 shows the distribution of the AMD data; the Malware types, number of samples, and number of varieties.

We performed byte code analysis for dex files of every malware sample. A feature vector (i.e., a profile) was created to represent each sample of the dataset. This profile is extracted by computing the byte-frequency of the data in each sample. The resulting matrix  $\mathbb{A}$  has the form:

$$\mathbb{A}_{m,n} = \begin{pmatrix} a_{1,1} & a_{1,2} & \cdots & a_{1,n} \\ a_{2,1} & a_{2,2} & \cdots & a_{2,n} \\ \vdots & \vdots & \ddots & \vdots \\ a_{m,1} & a_{m,2} & \cdots & a_{m,n} \end{pmatrix}$$

where  $a_{i,j}$  is the frequency of byte  $j = \{1, 2, \dots, n\}$  in the sample  $i = \{1, 2, \dots, m\}$ ,  $n = 256$  and  $m = 24553$ .

Malware Type	Number of Samples	Number of Varieties
Adware	14163	8
Backdoor	1047	24
Ransom	2148	11
Trojan-Banker	929	19
Trojan-Dropper	301	7
Trojan-SMS	3219	28
Trojan	517	16
Trojan-Spy	1851	4
Trojan-Clicker	31	2
Hackertool	347	16

Figure 4: An illustration of the distribution of Malware Type, Number of Samples, and Varieties in the AMD dataset.

## 8 THE EXPERIMENTAL DESIGN FOR PH ANALYSIS ON A ANDROID MALWARE DATASET

The primary objective of the experiment is to confirm the validity of utilizing PH in detecting anomalies within a specified dataset of software structures, namely Android malware. This application forms a prototype for PH detection capabilities which in conjunction with standard approaches may enhance our understanding of cybersecurity concerns. Its results strongly indicate the need for further testing of PH and TDA in other computer science fields.

The experiment used the Android Malware Dataset (AMD) described in section 7. AMD contains 10 malware types divided into 71 families of 135 varieties totaling 24553 samples. The entire AMD is available at <http://amd:arguslab.org/>. For the reader's convenience a concise summary of the AMD is shown in figure 5.

For this experiment we utilized the original family names from the AMD classification with some slight modifications. For example, consider the HackerTool Malware type family Lotoor which has a total of 15 varieties with 329 samples. Here we will say LotoorV14 to indicate the 14th variety of the Lotoor family. In order to be consistent in our experiment every family of the AMD will have a variety indicator even if only one variety is present. Thus AirpushV1 would be the Adware type Airpush family variety 1 with 7843 samples.

We begin with the choice of a reference sample to test the validity of anomaly detection within the AMD. For our experiment we choose LotoorV14 as our reference variety. Consulting <http://amd:arguslab.org/> of [89] we find that the HackerTool type Lotoor family has

## PERSISTENT HOMOLOGY BASED DATA ANALYTICS: DETECTING ANOMALIES IN ANDROID MALWARE

Paul T. Schrader, Rami Alroobi, Md Karim

Type	Family	Varieties	Samples
Adware	Airpush	1	7843
Adware	AndUp	1	45
Adware	Dowgin	1	3385
Adware	Kuguo	1	1199
Adware	Kyview	1	175
Adware	Minimob	1	203
Adware	Utchi	1	12
Adware	Youmi	1	1307
Backdoor	AndroRAT	1	46
Backdoor	DroidKungFu	6	546
Backdoor	FakeAngry	2	10
Backdoor	Fjcon	1	16
Backdoor	Fobus	1	4
Backdoor	GingerMaster	7	128
Backdoor	GoldDream	1	53
Backdoor	Obad	1	9
Backdoor	Spambot	1	15
Backdoor	Triada	1	210
Backdoor	Univert	1	10
HackerTool	Lotoor	15	329
HackerTool	Penetho	1	18
Ransom	Aples	1	21
Ransom	Fusob	2	1277
Ransom	Jisut	1	560
Ransom	Koler	2	69
Ransom	Roop	1	48
Ransom	SimpleLocker	4	173
Trojan	FakeAV	1	5
Trojan	FakeDoc	1	21
Trojan	FakeTimer	2	12
Trojan	FakeUpdates	1	5
Trojan	Lnk	1	5
Trojan	Ksapp	1	36
Trojan	Mmarketpay	1	14
Trojan	MobileTX	1	17
Trojan	Mseg	1	235
Total			
Trojan	Mtk	3	67
Trojan	Nandrobox	2	76
Trojan	UpdtKiller	1	24
Trojan-Banker	BankBot	8	650
Trojan-Banker	Bankun	4	70
Trojan-Banker	SlemBunk	4	174
Trojan-Banker	Svpeng	1	13
Trojan-Banker	Zitmo	2	24
Trojan-Clicker	Steek	1	12
Trojan-Clicker	Winge	1	19
Trojan-Dropper	Boqx	2	215
Trojan-Dropper	Gorpo	1	36
Trojan-Dropper	Kemoge	1	15
Trojan-Dropper	Ramnit	1	8
Trojan-Dropper	VikingHorde	1	7
Trojan-Dropper	Ztorg	1	20
Trojan-SMS	Boxer	1	44
Trojan-SMS	Cova	2	17
Trojan-SMS	Erop	1	46
Trojan-SMS	FakeInst	5	1772
Trojan-SMS	FakePlayer	2	21
Trojan-SMS	Gumen	1	145
Trojan-SMS	Leech	3	128
Trojan-SMS	Ogel	1	6
Trojan-SMS	Opfake	2	10
Trojan-SMS	RuMMS	4	402
Trojan-SMS	SmsKey	2	165
Trojan-SMS	SpyBubble	1	10
Trojan-SMS	Stealer	1	25
Trojan-SMS	Tesbo	1	5
Trojan-SMS	Vidro	1	23
Trojan-Spy	Finspy	1	9
Trojan-Spy	Mecor	1	1820
Trojan-Spy	SmsZombie	1	9
Trojan-Spy	Vmvol	1	13
Total			
10	71	135	24553

Figure 5: A Summarization of the AMD

15 varieties and LotoorV14 contains 19 samples (see figure 6). This choice was based on its moderate sample size and the families number of varieties. Our experiment consisted of testing for anomaly detection at two different levels of classification. For one test run we considered if PH could detect an anomaly from a different variety in the same family. So we removed one random sample from LotoorV14 and then added one random sample from another variety for all other 14 Lotoor varieties. For our second run we tested if PH could detect an anomaly from a different family. So we removed one random sample from LotoorV14 and then added one random sample from another family for all remaining 119 varieties. These tests were performed with the AMD using its full 256 dimensional data structure (based on byte frequencies) and with the AMD under PCA reduced to 70 dimensions. To indicate that we are using a family under this PCA we will write, for example, PCA70LotoorV14.

All computations for the PH analysis were performed in the *R* statistical software open source platform using the TDA package. This TDA package generates associated Rips complexes (though other platforms such as GUDHI and Ripser), computes the PH, and produces standard PH visualization formats such as persistence diagrams (PD), the bar codes (BC), and the persistence landscapes (PL). We generated a PD, BC, and PL for each instance

Type	Family	Variety	Samples
HackerTool	Lotoor	1	18
HackerTool	Lotoor	2	67
HackerTool	Lotoor	3	4
HackerTool	Lotoor	4	89
HackerTool	Lotoor	5	3
HackerTool	Lotoor	6	74
HackerTool	Lotoor	7	11
HackerTool	Lotoor	8	7
HackerTool	Lotoor	9	6
HackerTool	Lotoor	10	11
HackerTool	Lotoor	11	5
HackerTool	Lotoor	12	6
HackerTool	Lotoor	13	7
HackerTool	Lotoor	14	19
HackerTool	Lotoor	15	2
		Total	329

Figure 6: A Summarization of the Lotoor Family

of anomaly in both test runs. Since introducing an anomaly affects the structure of the generated Rips complex associated to the AMD reference sample and deforms its topology the resulting PH changes. In turn, the visualizations of the PH qualitatively change such that they are rendered distinct by inspection. This results in an anomaly detection when its visualizations (i.e., the PL, BC, and PL) are compared to the control visualizations of that same reference variety.

## 9 RESULTS

The goal of this section is to present the results of our experiment and explain them. Due to the limited space, selected but representative results are presented. The remaining results, including those of the unreduced AMD data set of 256 features or dimensions, can be available from the authors.

Each row-wise trio of graphs in Figure 7 presents the PD, BC, and PL (see section 6) results for eight different combinations of a chosen reference group, namely variety 14 of the HackerTool family Lotoor (see Figure 5), containing 19 samples. The upper leftmost trio in Figure 7 is our control of this reference group. The remaining 7 row-wise trios in this figure are created by replacing a single sample in our reference group with another unique variety, or anomaly, of the Hackerware family Lotoor. Notice by comparative inspection of the remaining 7 trios to the control trio, particularly in each rightmost PL, the qualitative (or geometric) deformation each anomaly makes to the control’s visualization. These perceptible changes indicate a “detection” of the anomaly within each variety of Lotoor.

The same configuration described above applies to Figure 8 except that we do not include another copy of our control trio. In these 8 cases, each row-wise trio of graphs contains the PD, BC, and PL of 18 samples of variety 14 of the Lotoor family and 1 unique non-Lotoor species from various other malware families listed in Figure ???. Again, particularly when using the PL in the control trio seen in the upper leftmost of Figure 7, by comparative inspection one can visually detect the deformation that the introduction of these anomalies produces. Again we see perceptible changes indicating a “detection” of the anomaly from



other families.

These visualizations clearly demonstrate that PH detects the inclusion of a malware sample in an input dataset, whether that sample comes from the same species or a different species of malware. Visually, many variants from the same species demonstrated smaller perturbation in the output than samples from different species. However, we also noticed some counter examples to this behavior. Without further investigation, a conclusive remark cannot be made. The possible reasons for this is explained in the conclusion below.

## 10 CONCLUSION AND FUTURE WORK

We noticed that PH is sensitive to the inclusion of a malware sample in a dataset and can possibly be used in developing methods for identifying relationships among malware variants and species. The state of the presented work is ongoing and we noticed some counter-intuitive examples. One possible reason that prohibits clean separation of different species of malware is their cross-pollination; most malware authors do not create a malware from scratch, they re-use existing codes instead (see [56]). We are investigating if cross-pollination can explain the counterexamples in our results, and, instead of using Persistent Homology for classification purposes, we can use it as a phylogenetic tool to express relationships among malware. Additionally, in our study we utilized bytecodes as features. Byte codes are not highly distinguishing. We plan to use semantically enriched features in our follow up studies and expect to see finer results.

The study also shows PH's promise in identifying anomalies which may have broad applications in designing scalable and real time cyber security monitoring tools, especially when big data is involved.

PERSISTENT HOMOLOGY BASED DATA ANALYTICS: DETECTING ANOMALIES IN ANDROID MALWARE  
 Paul T. Schrader, Rami Alroobi, Md Karim

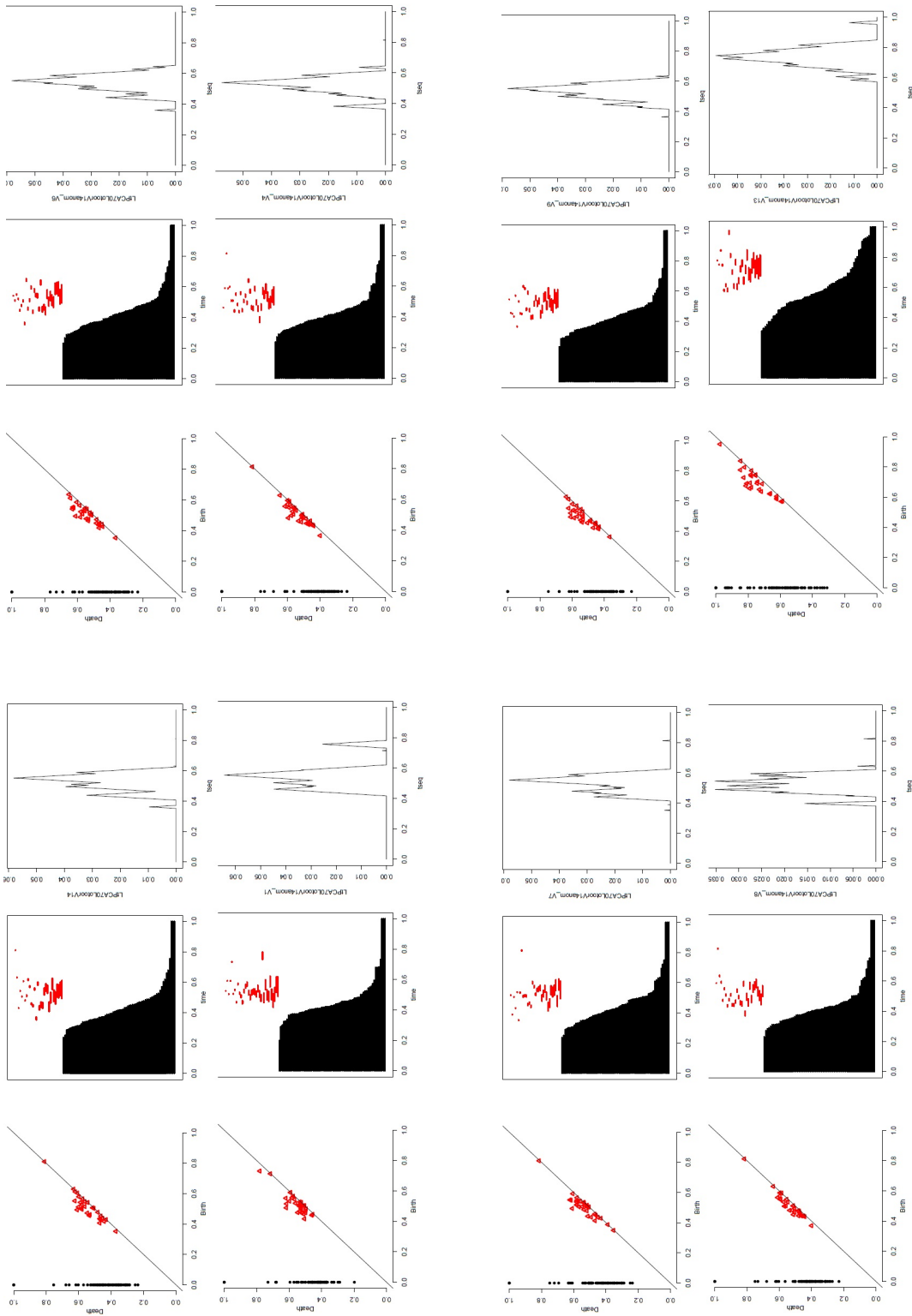

Figure 7: PH analysis for different combinations of variants of HackerTool family "Lotoor"

PERSISTENT HOMOLOGY BASED DATA ANALYTICS: DETECTING ANOMALIES IN ANDROID MALWARE  
 Paul T. Schrader, Rami Alroobi, Md Karim

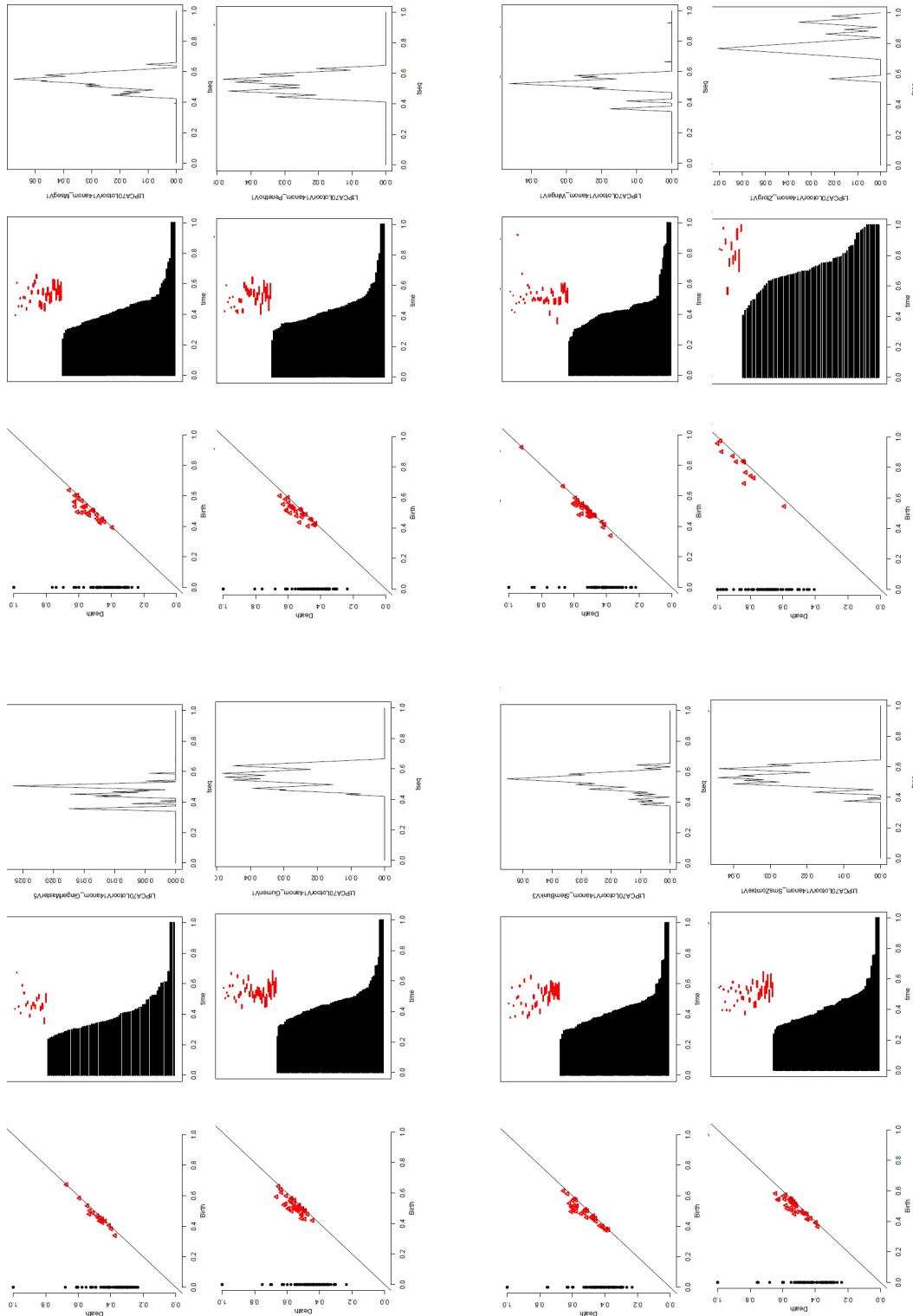

Figure 8: PH analysis when a combination of variants of HackerTool family "Lotoor" includes a sample from a different species

## REFERENCES

- [1] VirusShare. <https://virusshare.com/>. Accessed: 2018-12-20.
- [2] VirusTotal. <https://www.virustotal.com/>. Accessed: 2018-12-20.
- [3] Mohammed K. Alzaylaee, Suleiman Y. Yerima, and Sakir Sezer. Emulator vs real phone: Android malware detection using machine learning. In *IWSPA@CODASPY*, 2017.
- [4] Abdelfattah Amamra, Chamseddine Talhi, and Jean-Marc Robert. Smartphone malware detection: From a survey towards taxonomy. *2012 7th International Conference on Malicious and Unwanted Software*, pages 79–86, 2012.
- [5] Brandon Amos, Hamilton A. Turner, and Jules White. Applying machine learning classifiers to dynamic android malware detection at scale. *2013 9th International Wireless Communications and Mobile Computing Conference (IWCMC)*, pages 1666–1671, 2013.
- [6] Belal Amro. Personal mobile malware guard pmmg: a mobile malware detection technique based on user’s preferences. *CoRR*, abs/1802.04328, 2018.
- [7] Daniel Arp, Michael Spreitzenbarth, Malte Hubner, Hugo Gascon, and Konrad Rieck. Drebin: Effective and explainable detection of android malware in your pocket. In *NDSS*, 2014.
- [8] Saba Arshad, Munam Ali Shah, Abid Khan, and Mansoor Ahmed. Android malware detection and protection: A survey. *International Journal of Advanced Computer Science and Applications*, 7(2), 2016.
- [9] Steven Arzt, Siegfried Rasthofer, Christian Fritz, Eric Bodden, Alexandre Bartel, Jacques Klein, Yves Le Traon, Damien Octeau, and Patrick D. McDaniel. Flowdroid: precise context, flow, field, object-sensitive and lifecycle-aware taint analysis for android apps. In *PLDI*, 2014.
- [10] Kathy Wain Yee Au, Yi Fan Zhou, Zhen Huang, and David Lie. Pscout: analyzing the android permission specification. In *ACM Conference on Computer and Communications Security*, 2012.
- [11] Michael Backes, Sebastian Gerling, Christian Hammer, Matteo Maffei, and Philipp von Styp-Rekowsky. Appguard - fine-grained policy enforcement for untrusted android applications. In *DPM/SETOP*, 2013.
- [12] Michael Bailey, Jon Oberheide, Jon Andersen, Zhuoqing Morley Mao, Farnam Jahanian, and Jose Nazario. Automated classification and analysis of internet malware. In *RAID*, 2007.

- [13] Ulrich Bauer, Michael Kerber, Jan Reininghaus, and Hubert Wagner. PHAT—persistent homology algorithms toolbox. In *Mathematical software—ICMS 2014*, volume 8592 of *Lecture Notes in Comput. Sci.*, pages 137–143. Springer, Heidelberg. Softwar available at <https://code.google.com/p/phat/>, 2014.
- [14] Ulrich Bayer, Paolo Milani Comparetti, Clemens Hlauschek, Christopher Krügel, and Engin Kirda. Scalable, behavior-based malware clustering. In *NDSS*, 2009.
- [15] Bendich, P. & Kerber, M. & Edelsbrunner, H. Computing robustness and persistence for images. *IEEE Transactions on Visualization & Computer Graphics*, 16:1251–1260, 09 2010.
- [16] T. Bläsing, L. Batyuk, A. Schmidt, S. A. Camtepe, and S. Albayrak. An android application sandbox system for suspicious software detection. In *2010 5th International Conference on Malicious and Unwanted Software*, pages 55–62, Oct 2010.
- [17] Joseph Bonneau, Andrew Miller, Jeremy Clark, Arvind Narayanan, Joshua A. Kroll, and Edward W. Felten. Sok: Research perspectives and challenges for bitcoin and cryptocurrencies. *2015 IEEE Symposium on Security and Privacy*, pages 104–121, 2015.
- [18] Peter Bubenik. Statistical topological data analysis using persistence landscapes. *J. Mach. Learn. Res.*, 16:77–102, 2015.
- [19] Gunnar Carlsson. Topology and data. *Bull. Amer. Math. Soc. (N.S.)*, 46(2):255–308, 2009.
- [20] Gunnar Carlsson, Gurjeet Singh, and Afra Zomorodian. Computing multidimensional persistence. In *Algorithms and computation*, volume 5878 of *Lecture Notes in Comput. Sci.*, pages 730–739. Springer, Berlin, 2009.
- [21] Frédéric Chazal. High-Dimensional Topological Data Analysis. In *3rd Handbook of Discrete and Computational Geometry*. CRC Press, 2016. to appear.
- [22] Frédéric Chazal and Bertrand Michel. An introduction to topological data analysis: fundamental and practical aspects for data scientists. *CoRR*, abs/1710.04019, 2017.
- [23] Kevin Zhijie Chen, Noah M. Johnson, Vijay D’Silva, Shuaifu Dai, Kyle MacNamara, Thomas R. Magrino, Edward XueJun Wu, Martin C. Rinard, and Dawn Xiaodong Song. Contextual policy enforcement in android applications with permission event graphs. In *NDSS*, 2013.
- [24] Erika Chin, Adrienne Porter Felt, Kate Greenwood, and David A. Wagner. Analyzing inter-application communication in android. In *MobiSys*, 2011.
- [25] Corinna Cortes and Vladimir Vapnik. Support-vector networks. *Machine Learning*, 20(3):273–297, Sep 1995.

- [26] Lucas Davi, Alexandra Dmitrienko, Christopher Liebchen, and Ahmad-Reza Sadeghi. Over-the-air cross-platform infection for breaking mtan-based online banking authentication. 2012.
- [27] Benjamin Davis, Ben Sanders, Armen Khodaverdian, and Hao Chen. I-arm-droid : A rewriting framework for in-app reference monitors for android applications. 2012.
- [28] Luke Deshotels, Vivek Notani, and Arun Lakhotia. Droidlegacy: Automated familial classification of android malware. In *PPREW@POPL*, 2014.
- [29] Anthony Desnos and Geoffroy Gueguen ESIEA. Android : From reversing to decompilation. 2011.
- [30] D. Eastlake and P. Jones. Rfc3174: Us secure hash algorithm 1 (sha1). 2001.
- [31] Herbert Edelsbrunner and John Harer. Persistent homology—a survey. In *Surveys on discrete and computational geometry*, volume 453 of *Contemp. Math.*, pages 257–282. Amer. Math. Soc., Providence, RI, 2008.
- [32] Herbert Edelsbrunner, David Letscher, and Afra Zomorodian. Topological persistence and simplification. *Discrete Comput. Geom.*, 28(4):511–533, 2002. Discrete and computational geometry and graph drawing (Columbia, SC, 2001).
- [33] Herbert Edelsbrunner and Dmitriy Morozov. Persistent homology: theory and practice. In *European Congress of Mathematics*, pages 31–50. Eur. Math. Soc., Zürich, 2013.
- [34] Edelsbrunner, H. & Harer, J. *Computational Topology, An Introduction*. American Mathematical Society, 2010.
- [35] Samuel Eilenberg and Norman Steenrod. *Foundations of algebraic topology*. Princeton University Press, Princeton, New Jersey, 1952.
- [36] William Enck, Peter Gilbert, Byung-Gon Chun, Landon P. Cox, Jaeyeon Jung, Patrick D. McDaniel, and Anmol Sheth. Taintdroid: An information-flow tracking system for realtime privacy monitoring on smartphones. In *OSDI*, 2010.
- [37] Parvez Faruki, Vijay Ganmoor, Vijay Laxmi, Manoj Singh Gaur, and Ammar Bharmal. Androsimilar: robust statistical feature signature for android malware detection. In *SIN*, 2013.
- [38] Fasy, Brittany Terese & Lecci, Fabrizio & Rinaldo, Alessandro & Wasserman, Larry & Balakrishnan, Sivaraman & Singh, Aarti. Confidence sets for persistence diagrams. *Ann. Statist.*, 42(6):2301–2339, 12 2014.
- [39] Adrienne Porter Felt, Erika Chin, Steve Hanna, Dawn Xiaodong Song, and David A. Wagner. Android permissions demystified. In *ACM Conference on Computer and Communications Security*, 2011.
- [40] Adrienne Porter Felt, Matthew Finifter, Erika Chin, Steve Hanna, and David A. Wagner. A survey of mobile malware in the wild. In *SPSM@CCS*, 2011.

- [41] Yu Feng, Saswat Anand, Isil Dillig, and Alexander Aiken. Apposcopy: semantics-based detection of android malware through static analysis. In *SIGSOFT FSE*, 2014.
- [42] Adam Fuchs, Avik Chaudhuri, and Jeffrey S. Foster. Scandroid : Automated security certification of android applications. 2009.
- [43] GartnerInc. Gartner says worldwide sales of smartphones recorded first ever decline during the fourth quarter of 2017, 2018. Accessed: 2018-12-09.
- [44] Robert Ghrist. *Elementary Applied Topology*. ISBN 9781502880857, 2014.
- [45] Ghrist, Robert. Barcodes: The persistent topology of data. Technical report, University of Pennsylvania, 2007.
- [46] Clint Gibler, Jonathan Crussell, Jeremy Erickson, and Hao Chen. Androidleaks: Automatically detecting potential privacy leaks in android applications on a large scale. In *TRUST*, 2012.
- [47] Michael C. Grace, Yajin Zhou, Qiang Zhang, Shihong Zou, and Xuxian Jiang. Riskranker: scalable and accurate zero-day android malware detection. In *MobiSys*, 2012.
- [48] M. Hajij, B. Wang, C. Scheidegger, and P. Rosen. Visual detection of structural changes in time-varying graphs using persistent homology. In *2018 IEEE Pacific Visualization Symposium (PacificVis)*. IEEE, April 2018.
- [49] Allen Hatcher. *Algebraic topology*. Cambridge University Press, Cambridge, 2002.
- [50] Johannes J M L Hoffmann, Martin Ussath, Thorsten Holz, and Michael Spreitzenbarth. Slicing droids: program slicing for smali code. In *SAC*, 2013.
- [51] Danijela Horak, Slobodan Maletić, and Milan Rajković. Persistent homology of complex networks. *J. Stat. Mech. Theory Exp.*, (3):P03034, 24, 2009.
- [52] Chun-Ying Huang, Yi-Ting Tsai, and Chung-Han Hsu. Performance evaluation on permission-based detection for android malware. 2012.
- [53] Abdullah Talha Kabakus, Ibrahim Alper Dogru, and Aydin Cetin. Apk auditor: Permission-based android malware detection system. *Digital Investigation*, 13:1–14, 2015.
- [54] Kaczynski, Tomasz & Mischaikow, Konstantin & Mrozek, Marian. *Computational homology*, volume 157 of *Applied Mathematical Sciences*. Springer-Verlag, New York, 2004.
- [55] FAYAZ KAMALI. Malware detection using integrated static and dynamic analysis. 2017.

- [56] Md. Enamul Karim, Andrew Walenstein, Arun Lakhotia, and Laxmi Parida. Malware phylogeny generation using permutations of code. *Journal in Computer Virology*, 1:13–23, 2005.
- [57] J. Kim, Yongho Yoon, and Kwangkeun Yi. Static analyzer for detecting privacy leaks in android applications. 2012.
- [58] J. Kim, Yongho Yoon, and Kwangkeun Yi. Static analyzer for detecting privacy leaks in android applications. 2012.
- [59] Kovacev-Nikolic, Violeta & Bubenik, Peter& Nikolić, Dragan & Heo, Giseon. Using persistent homology and dynamical distances to analyze protein binding. *Stat. Appl. Genet. Mol. Biol.*, 15(1):19–38, 2016.
- [60] Li Li, Alexandre Bartel, Tegawendé F. Bissyandé, Jacques Klein, Yves Le Traon, Steven Arzt, Siegfried Rasthofer, Eric Bodden, Damien Octeau, and Patrick D. McDaniel. Iccta: Detecting inter-component privacy leaks in android apps. *2015 IEEE/ACM 37th IEEE International Conference on Software Engineering*, 1:280–291, 2015.
- [61] Martina Lindorfer, Matthias Neugschwandtner, Lukas Weichselbaum, Yanick Fratantonio, Victor van der Veen, and Christian Platzer. Andrubis: 1,000,000 apps later: A view on current android malware behaviors. *2014 Third International Workshop on Building Analysis Datasets and Gathering Experience Returns for Security (BADGERS)*, pages 3–17, 2014.
- [62] Riyadh Mahmood, Nariman Mirzaei, and Sam Malek. Evodroid: Segmented evolutionary testing of android apps. In *Proceedings of the 22Nd ACM SIGSOFT International Symposium on Foundations of Software Engineering, FSE 2014*, pages 599–609, New York, NY, USA, 2014. ACM.
- [63] Clément Maria, Jean-Daniel Boissonnat, Marc Glisse, and Mariette Yvinec. The gudhi library: Simplicial complexes and persistent homology. In Hoon Hong and Chee Yap, editors, *Mathematical Software – ICMS 2014*, pages 167–174, Berlin, Heidelberg, 2014. Springer Berlin Heidelberg. Software available at <https://project.inria.fr/gudhi/software/>.
- [64] Niall McLaughlin, Jesús Martínez del Rincón, BooJoong Kang, Suleiman Y. Yerima, Paul C. Miller, Sakir Sezer, Yeganeh Safaei, Erik Trickett, Ziming Zhao, Adam Doupé, and Gail-Joon Ahn. Deep android malware detection. In *CODASPY*, 2017.
- [65] J. Milnor. *Morse theory*. Based on lecture notes by M. Spivak and R. Wells. *Annals of Mathematics Studies*, No. 51. Princeton University Press, Princeton, N.J., 1963.
- [66] James R. Munkres. *Elements of algebraic topology*. Addison-Wesley Publishing Company, Menlo Park, CA, 1984.
- [67] James R. Munkres. *Topology*. Prentice Hall, Inc., Upper Saddle River, NJ, 2000. Second edition of [ MR0464128].



- [68] Otter, Nina. *Software for Persistent Homology*, [https://people.maths.ox.ac.uk/otter/PH\\_programs](https://people.maths.ox.ac.uk/otter/PH_programs), 2015.
- [69] Otter, Nina & Porter, Mason A. & Tillmann, Ulrike & Grindrod, Peter & Harrington, Heather. A roadmap for the computation of persistent homology. *EPJ Data Science*, 6:1–38, 2015.
- [70] Steve Y. Oudot. *Persistence theory: from quiver representations to data analysis*, volume 209 of *Mathematical Surveys and Monographs*. American Mathematical Society, Providence, RI, 2015.
- [71] Alice Patania, Francesco Vaccarino, and Giovanni Petri. Topological analysis of data. *EPJ Data Science*, 6(1):7, Jun 2017.
- [72] Siegfried Rasthofer, Steven Arzt, and Eric Bodden. A machine-learning approach for classifying and categorizing android sources and sinks. In *NDSS*, 2014.
- [73] R. Raveendranath, V. Rajamani, A. J. Babu, and S. K. Datta. Android malware attacks and countermeasures: Current and future directions. In *2014 International Conference on Control, Instrumentation, Communication and Computational Technologies (ICCICCT)*, pages 137–143, July 2014.
- [74] Mohd Faizal Ab Razak, Nor Badrul Anuar, Rosli Salleh, and Ahmad Firdaus. The rise of malware. *J. Netw. Comput. Appl.*, 75(C):58–76, November 2016.
- [75] Alessandro Reina. A system call-centric analysis and stimulation technique to automatically reconstruct android malware behaviors. 2013.
- [76] Konrad Rieck, Thorsten Holz, Carsten Willems, Patrick Düssel, and Pavel Laskov. Learning and classification of malware behavior. In *DIMVA*, 2008.
- [77] R. Rivest. Rfc1321: The md5 message-digest algorithm. 1992.
- [78] Bhaskar Pratim Sarma, Ninghui Li, Christopher S. Gates, Rahul Potharaju, Cristina Nita-Rotaru, and Ian Molloy. Android permissions: a perspective combining risks and benefits. In *SACMAT*, 2012.
- [79] Ryo Sato, Daiki Chiba, and Shigeki Goto. Detecting android malware by analyzing manifest files. 2013.
- [80] Utkarsh Saxena, Om Prakash Bachhan, and Rana Majumdar. Static and dynamic malware behavioral analysis based on arm based board. *2015 2nd International Conference on Computing for Sustainable Global Development (INDIACom)*, pages 272–277, 2015.
- [81] Marcos Sebastián, Richard Rivera, Platon Kotzias, and Juan Caballero. Avclass: A tool for massive malware labeling. In *RAID*, 2016.
- [82] Bernadette J. Stolz, Heather A. Harrington, and Mason A. Porter. Persistent homology of time-dependent functional networks constructed from coupled time series. *Chaos*, 27(4):047410, 17, 2017.

- [83] Kimberly Tam, Ali Feizollah, Nor Badrul Anuar, Rosli Salleh, and Lorenzo Cavallaro. The evolution of android malware and android analysis techniques. *ACM Comput. Surv.*, 49:76:1–76:41, 2017.
- [84] Wei Tang, Guang Jin, Jiaming He, and Xianliang Jiang. Extending android security enforcement with a security distance model. *2011 International Conference on Internet Technology and Applications*, pages 1–4, 2011.
- [85] Mihai Vasilescu, Laura Gheorghe, and Nicolae Tapus. Practical malware analysis based on sandboxing. *2014 RoEduNet Conference 13th Edition: Networking in Education and Research Joint Event RENAM 8th Conference*, pages 1–6, 2014.
- [86] L. Vietoris. Über den höheren Zusammenhang kompakter Räume und eine Klasse von zusammenhangstreuen Abbildungen. *Math. Ann.*, 97(1):454–472, 1927.
- [87] Hubert Wagner, Chao Chen, and Erald Vuçini. Efficient computation of persistent homology for cubical data. In *Topological methods in data analysis and visualization II*, Math. Vis., pages 91–106. Springer, Heidelberg, 2012.
- [88] Hubert Wagner, Paweł Dłotko, and Marian Mrozek. Computational topology in text mining. In *Computational topology in image context*, volume 7309 of *Lecture Notes in Comput. Sci.*, pages 68–78. Springer, Heidelberg, 2012.
- [89] Fengguo Wei, Yuping Li, Sankardas Roy, Xinming Ou, and Wu Zhou. Deep ground truth analysis of current android malware. In *International Conference on Detection of Intrusions and Malware, and Vulnerability Assessment (DIMVA'17)*, pages 252–276, Bonn, Germany, 2017. Springer.
- [90] Fengguo Wei, Sankardas Roy, Xinming Ou, and Robby. A android: A precise and general inter-component data flow analysis framework for security vetting of android apps. *ACM Trans. Priv. Secur.*, 21:14:1–14:32, 2014.
- [91] C. C. White. Android malware past , present , and future. 2011.
- [92] Dong-Jie Wu, Ching-Hao Mao, Te-En Wei, Hahn-Ming Lee, and Kuo-Ping Wu. Droid-mat: Android malware detection through manifest and api calls tracing. *2012 Seventh Asia Joint Conference on Information Security*, pages 62–69, 2012.
- [93] Rubin Xu, Hassen Saïdi, and Ross J. Anderson. Aurasium: Practical policy enforcement for android applications. In *USENIX Security Symposium*, 2012.
- [94] Chao Yang, Zhaoyan Xu, Guofei Gu, Vinod Yegneswaran, and Phillip A. Porras. Droid-miner: Automated mining and characterization of fine-grained malicious behaviors in android applications. In *ESORICS*, 2014.
- [95] Wei Yang, Xusheng Xiao, Benjamin Andow, Sihan Li, Tao Xie, and William Enck. Appcontext: Differentiating malicious and benign mobile app behaviors using context. *2015 IEEE/ACM 37th IEEE International Conference on Software Engineering*, 1:303–313, 2015.

- [96] Min Zhao, Fangbin Ge, Tao Zhang, and Zhijian Yuan. Antimaldroid: An efficient svm-based malware detection framework for android. In *ICICA*, 2011.
- [97] Cong Zheng, Shixiong Zhu, Shuaifu Dai, Guofei Gu, Xiaorui Gong, Xinhui Han, and Wei Zou. Smartdroid: An automatic system for revealing ui-based trigger conditions in android applications. In *Proceedings of the Second ACM Workshop on Security and Privacy in Smartphones and Mobile Devices*, SPSM '12, pages 93–104, New York, NY, USA, 2012. ACM.
- [98] Cong Zheng, Shixiong Zhu, Shuaifu Dai, Guofei Gu, Xiaorui Gong, Xinhui Han, and Wei Zou. Smartdroid: an automatic system for revealing ui-based trigger conditions in android applications. In *SPSM@CCS*, 2012.
- [99] Min Zheng, Mingshen Sun, and John C. S. Lui. Droid analytics: A signature based analytic system to collect, extract, analyze and associate android malware. *2013 12th IEEE International Conference on Trust, Security and Privacy in Computing and Communications*, pages 163–171, 2013.
- [100] Wu Zhou, Yajin Zhou, Xuxian Jiang, and Peng Ning. Detecting repackaged smartphone applications in third-party android marketplaces. In *CODASPY*, 2012.
- [101] Yajin Zhou and Xuxian Jiang. Dissecting android malware: Characterization and evolution. *2012 IEEE Symposium on Security and Privacy*, pages 95–109, 2012.
- [102] Yajin Zhou and Xuxian Jiang. Detecting passive content leaks and pollution in android applications. In *NDSS*, 2013.
- [103] Yajin Zhou, Zhi Wang, Wu Zhou, and Xuxian Jiang. Hey, you, get off of my market: Detecting malicious apps in official and alternative android markets. In *NDSS*, 2012.
- [104] Afra Zomorodian. Topological data analysis. In *Advances in applied and computational topology*, volume 70 of *Proc. Sympos. Appl. Math.*, pages 1–39. Amer. Math. Soc., Providence, RI, 2012.
- [105] Afra Zomorodian and Gunnar Carlsson. Computing persistent homology. *Discrete Comput. Geom.*, 33(2):249–274, 2005.
- [106] Afra J. Zomorodian. *Topology for computing*, volume 16 of *Cambridge Monographs on Applied and Computational Mathematics*. Cambridge University Press, Cambridge, 2009. Reprint of the 2005 original [MR2111929].

**PREDICTING ALL-CAUSE 30-DAY HOSPITAL READMISSIONS: A FIRST STEP  
IN MODEL BENCHMARKING**

Stacey Mumbower, Darla Moore School of Business, University of South Carolina, 1014  
Greene Street, Columbia, SC 29208, 803-777-2941, stacey.mumbower@moore.sc.edu

Ronda Hughes, College of Nursing, University of South Carolina, 1601 Greene Street  
Columbia, SC 29208, hughesrg@mailbox.sc.edu

**ABSTRACT**

Utilizing data from a large randomized controlled trial that added risk assessment tools for nurses to use with patients as part of the discharge planning process, we benchmark models that predict all-cause 30-day hospital readmissions. We compare the performance of several commonly used machine learning models against binary logistic regression models and find that machine learning results in a modest increase in predictive ability.

A logistic regression model that incorporates only explanatory variables from the widely-used LACE Index Scoring Tool performs the worst with a test AUC of 0.709. A second logistic regression model that incorporates a more diverse set of variables results in a small increase in predictive ability (1.3% increase in AUC). The neural network, gradient boosting machine, and random forest all perform similarly with test AUCs of 0.736, 0.736, and 0.735 respectively (representing a 2.3 – 2.5% increase in test AUC over that of the second logistic regression model). The best overall model is an ensemble model with a test AUC of 0.743 (a 3.5% increase in test AUC over that of the second logistic regression model, and a 1% increase over the best individual model).

In a secondary analysis, we investigate predictive ability of the information collected as part of the new risk assessment tools for nurses. Prior analysis of the randomized trial found the new tools to be effective in some hospital units, significantly reducing readmissions. However, using information from these new tools as explanatory variables in the models results in only a slight increase in predictive ability (0.4% increase in test AUC).

As part of the model benchmarking process, we also compare predictive ability across different subsets of the data. We find that AUCs vary by hospital and type of diagnosis. These results have implications for using the predictive models as part of the hospitals' discharge planning process.

## Predictive Analytics using Machine Learning for Electronic Health Records

Arjumand Fatima, Department of Information Technology, Georgia Southern University, Statesboro, GA 30460, [af08128@georgiasouthern.edu](mailto:af08128@georgiasouthern.edu)

Hayden Wimmer\*, Department of Information Technology, Georgia Southern University, Statesboro, GA 30460, [hwimmer@georgiasouthern.edu](mailto:hwimmer@georgiasouthern.edu)

Cheryl Aasheim, Department of Information Technology, Georgia Southern University, Statesboro, GA 30460, [caasheim@georgiasouthern.edu](mailto:caasheim@georgiasouthern.edu)

### Abstract

Machine learning algorithms can play a vital role in different organizations such as healthcare. Using machine learning algorithms can impact the healthcare industry tremendously by predicting diseases outbreaks, mortality rates, monitoring risks, and many other factors. Being able to monitor and control these factors can help save the industry cost, and provide for better resource allocation. This paper aims to analyze different machine learning approaches for predicting hospital length of stay (LOS) using electronic health records (EHRs). The use of a machine learning model such as Logistic Regression(LR), Decision Trees and Neural Networks (NN) will be used along with python and SPSS to preprocess and prepare the data for prediction of hospital LOS. The results will show how the preprocessing phase of data can directly influence your results. Based on preprocessing of data, results could yield to a higher or lower accuracy of prediction models of patients' length of stay in the hospital. Predicting LOS can better assist and provide patients with the proper resources and help reduce hospital cost and provide for a better treatment for the patient. In conclusion, machine learning algorithms can be a vital part for the healthcare industry. It can help save cost, reduce failures and delays in medical settings and impact the healthcare industry tremendously

### Introduction

Predictive analytics using machine learning is an emerging topic in data analytics. Watson (2019) describes predictive analytics as a branch of advanced analytics that can be utilized in making predictions about unknown future events or activities that can eventually lead to decisions. Watson (2019) further mentions predictive analytics utilizes different techniques such as statistics, data mining, and machine learning to evaluate and analyze historical and real-time data to make predictions about the future [1]. Machine learning along with predictive analytics can be an extremely useful technique to make predictions in the healthcare industry. This discipline can help save costs, allow for resource allocation, predict future wellness, aid in diagnosis and more. Kumar & Pranavi (2017) define the data generated in healthcare field as very large, critical and more complex with multi dimensions. In order to analyze and understand such huge data and acquire relevant knowledge from the data is a challenging task [2].

Ghassemi, Naumann, Schulam, Beam, and Ranganath (2018) discuss machine learning from health datasets hold the potential to improve health care in many ways such as by delivering better patient treatments, improving operations, or answering fundamental scientific questions (Ghassemi, et al., 2018). This can also be useful when predicting patients' LOS. By being able to predict the length of stay

for patients, a hospital is better able to utilize its resources, aid in diagnosis and aid in room and bed logistics. This can allow for better planning and resource allocation. Tanuja, Acharya & Shailesh (2011) suggest predicting LOS will help hospitals in achieving benchmark performance levels in profitability, patient care and process efficiency. LOS is an important measure of health care utilization and determinant of hospitalization costs [3]. The main objective of this paper is to examine electronic health records to predict hospital length of stay and analyze different machine learning models suitable to allow for accurate predictions.

In this work we use a comprehensive approach to address the above challenge by comparing different machine learning techniques. This paper utilizes electronic health records obtained from the Medical Information Mart of Intensive Care (MIMIC) developed by the Massachusetts Institute of Technology lab. The data was preprocessed using several tools such as Python and SPSS. The final dataset consisted of records and attributes useful in predicting hospital length of stay. This final dataset consisted of around 53000 records along with 8 different attributes after being pre-processed in a way to minimize outliers and skewness of data. The final dataset was exported into SPSS and several different machine learning techniques were applied. In this paper we consider three different machine learning algorithms such as Logistic Regression(LR), CART Decision Tree and Neural Networks(NN) to predict length of stay. The results show that these three different machine learning techniques, LR, CART Decision Tree algorithms and Neural Networks showed approximately similar results around ~84% of accuracy when predicting length of stay > 3 days and < 3 days. When predicting length of stay for > 5 days and < 5 days, the results showed around ~70% of accuracy for all three models. When compared with similar studies, the results show how preprocessing can play a vital role in predicting accuracy of different machine learning models.

#### Literature Review

In our review, we found varying use machine learning techniques such as to predict hospital appointments, diseases, mortality and length of stay using different machine learning techniques. Each technique yielded different preprocessing techniques and varying degrees of accuracy. Ehlers, Roy, Khor, Mandagani, Maria, Alfonso-Cristancho, & Flum (2017) describe machine learning algorithms were used for risk prediction for adverse events following a surgery. A Naive Bayes algorithm was used to predict risk of adverse events or death within 90 days of surgery. This method was compared with a commonly used risk prediction tool Charlson's comorbidity index. Performance was assessed by measuring the area under the curve. The Naive Bayes algorithm predicted 79% of adverse effects and 78% of deaths while Charlson's comorbidity predicted 57% of adverse effects and 59% of deaths. This paper shows that while these algorithms can be used for several other things, they can be used to predict risk of an adverse effect following a surgery for a more patient centered decision making and for significant cost savings [4].

Sarwar, Kamal, Hamid, & Shah (2018) used six different machine learning methods and applied it to a diabetes dataset to measure performance and accuracy of these algorithms to reveal which method is best used to predict diabetes. Data was gathered and pre-processed. Coding was done in python using the Enthought Canopy package. Data was divided into two sets training and testing. The training data was first used on the machine learning model then the testing data was used to check the accuracy. This was done for all the six algorithms. The results showed that Support Vector Machine and K-Nearest Neighbor are appropriate for the prediction of the diabetes disease as they had the highest accuracy.

This paper discusses the different machine learning techniques and the best techniques that can be used for accurate predictions (Sarwar, et al. 2018).

Rojas, Carey, Edelson, Venable, Howell, & Churpek, (2018) aimed to use a machine learning based approach to predict and validate ICU readmissions by using real time variables in EHRs and comparing it to other machine learning algorithms. The authors used 60% of the transfers in the training dataset and 40% in the testing dataset. Characteristics such as medications, prior admissions, lab results, were extracted from the electronic health records and used as predictor variables in a gradient boosted machine learning model. Accuracy was compared with the stability and workload index for transfer score was used as well as modified early warning score. Results showed that the machine learning model had better performance with an area under the receiver operating curve (ROC) at 0.76 than the stability and workload index for transfer score with an area under the ROC curve of 0.65 or modified early warning score of an AUROC of 0.58. Using a machine learning model to predict ICU readmission was significantly more accurate than previously established algorithms. This paper shows how using a machine learning approach can benefit by targeting patients who may benefit from additional time in the ICU or require more frequent monitoring [5].

Ma, Khataniar, Wu, & Ng, (2014) study predictive analytics for outpatient appointments. Author uses logistic regression and recursive partitioning to predict patient appointments in hospitals that experience high volume of no shows to avoid poor patient satisfaction and loss of revenue for the hospital. Exploratory data analysis was used to find major causes of no shows. Then using techniques such as logistic regression and recursive partitioning were used to predict patients who have a high probability of no shows. The logistic regression model used in this paper predicted around 70% of the no shows cases correctly with a K-coefficient of 0.41 on the validation data. This paper gives an example of how predictive analytics can be applied to the different areas of healthcare industry (Ma, et al., 2014).

Karhade, Ogink, Thio, Broekman, Cha, Gormley, Hershman, Peul, Bono, Schwab (2018) use a machine learning approach such as neural networks for hospital length of stay (LOS) prediction. Hospital LOS can be prolonged if a patient is awaiting treatment at a rehab center or a nursing facility following a spine surgery. Using preoperative prediction of the likelihood of postoperative discharge after spine surgery can help decrease hospital length of stay. The use of machine learning algorithms to develop an open access web application is used to predict hospital length of stay after spine surgery. Four models, neural network, support vector machine, Bayes point machine and boosted decision tree models were used to predict 30-day mortality. Predictive factors such as age, sex, BMI, functional status, severity of comorbid diseases, diabetes and preoperative hematocrit level we used. The results showed that neural network was the best model with an area under the ROC curve of 0.823. This research shows another example of promising results of machine learning algorithms in regards to prediction of length of stay and being used in preoperative risk stratification [6].

Morton, Marzban, Giannoulis, Patel, Aparasu and Kakadiaris (2014) perform a study on the comparison of supervised machine learning techniques for predicting short-term in-hospital length of stay among diabetic patients. The objective of this paper was to use machine learning models such as multiple linear regression, support vector machines, multi-task learning, and random forest to predict long versus short length of stay in diabetic patients. Instead of predicting exact LOS, the authors predict short versus long term length of stay for each patient where less than three days is considered a short term LOS. They used attributes such as age, (under 18 years of age, between 18 and 65 years of age, over 65 years

of age), sex, Race, Expected Primary Payer, Admission Type, and the All Patient Refined DRG (APR-DRG) measure. A total of 10,000 records were used for prediction. The results show that among comparison of the different models, the support vector plus algorithm performed the best with an AUC of 0.76 and an accuracy of 68% following the random forest algorithm with an AUC of 0.70 and accuracy of 65% multi-task learning with AUC of 0.56 and accuracy of 55% and multiple linear regression with an AUC of 0.45 and accuracy of 50%. This paper provides an example of different machine learning techniques applied to hospital length of stay among diabetic patients and which technique performed the best in predicting short vs longer length of stay in patients [7].

Taleb, Hasant, & Khan (2017), used data from the Neurology department database of King Fahd Bin Abdul-Aziz Hospital. The dataset consists of 105 attributes and 866 stroke patients' records who were studied clinically to determine the level of stroke. The objective of this paper was to predict hospital length of stay and compare and identify the best performing algorithm. Two algorithms, Bayesian network and C4.5 decisions tree algorithm were used for prediction. The original data set consisted of 105 attributes out of which 54 were eliminated due to redundancy and irrelevancy. However, the other 51 attributes were ranked with respect to LOS and a process of elimination was applied to further narrow down to 16 attributes. A 10-fold cross validation method was used to evaluate prediction models constructed by using these two methods. Common classification metrics were used to measure the classification models using accuracy, sensitivity, specificity and area under the ROC curve. The results show that the accuracy of the Bayesian model is higher at 81.21% compared to the C4.5 decision tree algorithm at 77.1%. The performance of Bayesian model is also better in terms of AUC, sensitivity and specificity. This study only utilizes 866 stroke patients along with 51 attributes to eliminate redundancy and irrelevancy. show that better pre-processing of data can yield to a higher accuracy such as mentioned above [8].

Tanuja, Acharya, & Shailesh (2011) predict length of stay in patients during the first day of admission using four different techniques such as multilayer backpropagation NN, Naïve Bayes Classifier, K-NN method, C4.5 decision tree algorithm. The dataset used consisted of 40,000 electronic health records. Patient information was gathered from admission time and the discharge summary details to develop a model to predict length of stay. The model used 16 parameters as inputs to train the network. The duration of stay variable was categorized into three groups and these formed the output class for classification. The Bayes technique was used to follow a simple, clear and fast classifier. The results show that out of the four models, the Bayes model performed the second best after the multi-layer network model at 87.8% of accuracy whereas the Bayes model had an 85.5% accuracy. This paper provides an example of Bayesian network technique applied to hospital length of stay and showed that it performed better in comparison with a different machine learning algorithm [3].

Veith & Steele (2018) performed a study on the same data set used in this paper, MIMIC-III and the objective this paper was to use a large dataset of 58,000 ICU admissions to train and evaluate a number of all-condition patient mortality predictive models. A 5,000-row subset of data was used to increase the number of model configurations to test. After receiving the top 5 configurations, each model was re-trained and re-evaluated using the full dataset of 58,978 was used along and 10-fold cross validations. The training set results were higher across the board and the 10-fold cross validation results were close to their counterparts. The results show that the LazyKStar algorithm had the highest AUC at .721. Other models consisted of Logistic, Simple Logistic, Naïve Bayes, and BayesNet which show predictive potential with AUC scores ranging from 0.69 to 0.718. Since this paper considered all the records in the



data set, the AUC for all the models was around .70. In conclusion, pre-processing of data can have a direct effect on the results of the predictive models. Since the authors used the entire dataset to predict LOS, it resulted in AUC scores of around 0.70 [9].

Wang, McDermott, Chauhan, Hughes, Naumann, & Ghassemi (2019) used MIMIC-III dataset which is used in this paper to predict hospital LOS based on LOS > 3 days' prediction and LOS > 7 days' prediction. ICU admission were used for adult patients with age > 15 where LOS was between 12 hours and 10 days. The resulting cohort included 34,472 patients. The authors use systems clinically grouped time-varying labs and vitals features to predict this target as binary classification task. They used the first 24 hours of patients' data only considering patients with at least 30 hours of present data. Three different models were used for prediction including logistic regression, random forest and gated current unit with delay. The results show an accuracy of 68.6% for logistic regression, 69.5% for random forest and 68.3% for gated recurrent unit with delay for LOS > 3 days. For LOS > 7 days the results showed an accuracy of 91.9% for logistic regression, 92.3% for random forest and 91.2% for gated recurrent unit with delay. The results show higher accuracy for LOS >7 days when compared with LOS > 3 days. In conclusion, the authors method of pre-processing resulted with a lower accuracy of predictive models for LOS > 3 days but higher for LOS > 7 days [10].

#### Methods

##### Machine Learning Methods

##### Logistic Regression

Hosmer Jr, Lemeshow, & Sturdivant (2013), define logistic regression as the relationship between a categorical dependent variable along with one or more independent predictor variable. EMCE (2015), describe logistic regression can be used to predict the likelihood of an outcome based on the input variables. They further describe the use cases of logistic regression in public and private sectors including medical, finance, marketing and engineering [11].

$$f(y) = \frac{e^y}{1 + e^y} \text{ for } -\infty < y < \infty$$

as  $y \rightarrow \infty, f(y) \rightarrow 1$ , and as  $y \rightarrow -\infty, f(y) \rightarrow 0$

EMCE (2015) describe the range of  $f(y)$  is (0,1), the logistic function models the probability of a particular occurrence of an outcome. As the value of  $y$  increases, the probability of the outcome occurring also increases. To predict the likelihood of an outcome,  $y$  needs to be a function of the input variables. Therefore,  $y$  is expressed as a linear function of the input variables [11].

$$y = \beta_0 + \beta_1 x_1 + \beta_2 x_2 \dots + \beta_{p-1} x_{p-1}$$

Based on the input, the probability of an outcome can be shown as

$$p(x_1, x_2, \dots, x_{p-1}) = f(y) = \frac{e^y}{1 + e^y} \text{ for } -\infty < y < \infty$$

##### CART Decision Tree

EMCE (2015), define a decision tree as a prediction tree which uses a tree structure to specify sequences of decisions and consequences. Given an input  $X = \{x_1, x_2, \dots, x_n\}$ , the goal is to predict a response or output variable  $Y$ . The prediction can be achieved by constructing a decision tree with test points and

branches. At each test point, a decision is made to pick a specific branch and traverse down the tree. Eventually, a final point is reached, and a prediction can be made. Each test point in a decision tree involves testing a particular attribute, and each branch represents the decision being made [11].

CART decision tree is used for this study. EMCE (2015) describe CART as a Classification and Regression tree which can handle continuous attributes. It further describes CART as a method which constructs a sequence of subtrees, uses cross-validation to estimate the misclassification cost of each subtree, and chooses the one with the lowest cost [11].

#### Neural Networks

Gentimis, Ala’J, Durante, Cook, & Steele, (2017) describe Neural Networks as one of the most prominent tools for analyzing big data sets. It describes NN as an algorithm which emulates the “learn by example” technique that is used to understand any phenomenon. Inside the core of a NN is a directed graph of nodes and connectors, called neurons and synapses. Each layer of neurons is connected to the next one using a set of activation functions (Gentimis, et al., 2017).

Gentimis, Ala’J, Durante, Cook, & Steele, (2017) further explains neural networks that require large data sets to train, more specifically when the input for a specific model can be broken down into several categories. Due to the rapid increase in the availability of digitized health data, NN potentially provides a powerful approach for research and health analytics applications (Gentimis, et al., 2017).

Larose & Larose (2014) describe neural networks first use a combination function to produce a linear combination of the node inputs and the connection weights into a single scalar value, which in this case is known as net, for a given node  $j$ . The combination function is defined below (Larose & Larose, 2014).

$$net_j = \sum_i W_{ij}x_{ij} = W_{0j}x_{0j} + W_{1j}x_{1j} + \dots + W_{Ij}x_{Ij}$$

where  $x_{ij}$  represents the  $j$ th input to node  $j$ ,  $W_{ij}$  represents the weight associated with the  $j$ th input to node  $j$ , and there are  $I + 1$  inputs to node  $j$

Larose & Larose, (2014) define the net of the combination function is used as an input to an activation function. In biological sense, signals are sent between neurons when the combination of inputs to a particular neuron cross a certain threshold. The neuron then fires. This behavior of neurons firing is not linearly related to the increment in input simulation therefore this can be defined as nonlinear behavior. This behavior can be modeled in neural networks using an activation function. The most common activation function is known as the sigmoid function which is defined below (Larose & Larose, 2014).

$$y = \frac{1}{1 + e^{-x}}$$

Gentimis, Ala’J, Durante, Cook, & Steele (2017) further explains neural networks that require large data sets to train, more specifically when the input for a specific model can be broken down into several categories. Due to the rapid increase in the availability of digitized health data, NN potentially provides a powerful approach for research and health analytics applications (Gentimis, et al., 2017).

#### Data Source

For the purpose of this study, the data was obtained from the Medical Information Mart for Intensive Care, MIMIC-III. MIMIC-III is the current version of the MIMIC database which integrates comprehensive de-identified clinical data of patients admitted to the Beth Israel Deaconess Medical Center in Boston, Massachusetts, and it is widely accessible to researchers under a data use agreement. The dataset consists of data more than a decade, with detailed information about individual patient care. A course in protecting human research participants that includes Health Insurance Portability and Accountability Act (HIPAA) requirements is required as well as a data use agreement must be signed which outlines the appropriate use of data and security standards. The database is available for international research and education as well under a data use agreement.

The MIMIC-III dataset comprises of data associated with 58,976 distinct hospital admission events and around 46,520 unique patients between 2001 and 2012. The database includes information such as demographics, vital sign measurements, laboratory test results, procedures, medications, caregiver notes, imaging reports, and mortality. The MIMIC-III database is a popular and widely used database used for acquiring hospital related electronic health record data. Several studies have used this database for the purposes of research and have applied machine learning and deep learning techniques. As with most data sets, the MIMIC-III dataset requires data exploration, formatting and preprocessing before it can be used further.

In order to gain access to the data, first a “Data or Specimens Only Research” course was completed through the MIT website. Then an account was created on PhysioNet and an application was filed to request access to the data set. After being granted access, the files in the record consisted of multiple different datasets out of which three datasets were used named:

- ADMISSIONS.csv,
- PATIENTS.csv,
- DIAGNOSIS\_ICD.csv,

The datasets ADMISSIONS.csv consisted of information regarding a patient’s admission to the hospital. Information available includes timing information for admission and discharge, demographic information, the source of the admission, and more and consists of 58,976 rows. The PATIENTS.csv defines each patient in the database and consists of date of birth, date of death, and gender and a total of 46,520 rows. Finally, the DIAGNOSIS\_ICD.csv consist of ICD diagnoses for patients, most notably ICD-9 diagnoses which consist of 651,047 rows. All of these datasets are linked to each other through a unique subject ID (SUBJECT\_ID) and a hospital admission ID (HADM\_ID).

#### Data Preparation

##### Python

The data obtained from the MIMIC-III database was in a structured format with appropriate headers, columns and rows as it was in a CSV file. Since this research focuses on hospital length of stay, the data was preprocessed appropriately to remove any irrelevant or unused attributes, columns and rows from the four datasets. The dataset of ADMISSIONS had several different attributes including, Subject ID, HADM ID, admission time, discharge time, admission type, insurance, marital status, and ethnicity. Out of the total of 19 attributes in this dataset, only 8 were relevant for predicting hospital length of stay. Other attributes such as admission location, discharge location, language, religion, death time and time patient was admitted and discharged from emergency, and hospital expire flag which indicates whether the patient died or is still alive were excluded.

The length of stay is identified as the target variable or the dependent variable for this study. In order to calculate the length of stay, the discharge time was subtracted from the admission time. A python script was written to omit any irrelevant variables and to also calculate the hospital length of stay. The script was also used to remove patients that had a negative length of stay, such as patients that died before admission. Also, patients who died at the hospital were also dropped as it would result in a biased LOS since the patients were never discharged alive from the hospital, and the length of stay would be shorter for these patients. A new LOS column was created to analyze length of stay  $> 3$  &  $< 3$  days with LOS  $> 3$  days being “longer” and LOS  $< 3$  days being “shorter”. This was also done for length of stay  $> 5$  &  $< 5$  days with LOS  $> 5$  days being “longer” and LOS  $< 5$  days being “shorter”.

In the DIAGNOSIS\_ICD table, only Subject ID, HADM ID and the ICD-9 Codes were the only relevant attributes. For this table, first, it was determined how many unique ICD-9 codes were part of the dataset. There were around 6,984 unique codes for this dataset. In order to reduce this number, the list of ICD-9 codes was re-coded in terms of categorical variables. ICD-9 codes consist of 17 categories therefore after re-coding, the category ranges were assigned for each code and an associated category name was assigned to the category range with a final total of 17 categories. Then the values were re-coded in terms of integers and the integers were then assigned to the appropriate category name. By reducing the number of categories it allows for a more accurate and clean prediction model.

#### SPSS

In order to further analyze the data, this finalized dataset was exported into Statistical Package for Social Sciences (SPSS) by IBM. After importing the data into SPSS, three different types of analysis would be performed on this dataset, a logistic regression model, CART decision tree model and neural networks.

First, a binary logistic model was performed for each attribute being the independent variable and the length of stay being the dependent variable. The model was analyzed for admission type, gender, ethnicity, age, marital status, insurance type, and the ICD9 diagnosis categories against length of stay for  $> 3$  &  $< 3$  days and for  $> 5$  &  $< 5$  days. In this case, the age, admission type, gender, ethnicity, marital status, and insurance type were categorical variables and therefore these were defined in SPSS before running the binary logistic model. Second, the decision tree model was analyzed for all the attributes compared with the dependent variable of length of stay for  $> 3$  &  $< 3$  days and for  $> 5$  &  $< 5$  days. For this analysis, the CRT decision tree was used as CRT decision tree provides a detailed and an in-depth tree. Therefore, all the independent attributes were tested against length of stay using the CRT decision tree method in SPSS. Third, a multilayer perception of Neural Networks model was analyzed for all the attributes against the dependent variable length of stay for  $> 3$  &  $< 3$  days and  $> 5$  &  $< 5$  days.

#### Results

The results for three machine learning techniques, binary logistic regression, CART decision tree and neural networks are shown in the figure below. The results show the prediction accuracy for LOS  $> 3$  days and  $< 3$  days for logistic regression to be at 84.3%, CART decision tree to be at 84.2% and neural networks at 84.1%. The results for length of stay  $> 5$  days and  $< 5$  days for logistic regression was 73.1%, CART decision tree was 71% and neural networks was 71.7%. [10], used a similar approach to predict LOS which yielded with an accuracy of 68.6% for logistic regression for LOS  $> 3$  days as compared to our model which was 84.3%. We believe the higher accuracy in our study shows a direct

emphasis on the preprocessing stage of data which therefore resulted in our study to have a higher accuracy.

Wang, et al., (2019) uses a cohort which included 34,472 patients in their final dataset. They used the first 24 hours of patients' data only considering patients with at least 30 hours of present data. They also use clinically grouped time-varying labs and vitals features to predict LOS as binary classification task [10]. Our predictive models developed in this research is not constrained to a specific health condition or group of conditions as used in previous studies when using the MIMIC-III dataset to predict LOS. Our models are simple and generalized models which do not require any clinical information such as physiological data, lab vitals, etc., to calculate and predict an outcome.

Machine Learning Technique	Prediction accuracy for LOS > 3 & < 3 days	Prediction accuracy for LOS > 5 & < 5 days
<b>Binary Logistic Regression</b>	84.3%	73.1%
<b>Decision Tree - CART</b>	84.2%	71.0%
<b>Neural Networks</b>	84.1%	71.7%

#### Conclusion

In conclusion, LOS can be an important variable in the health care industry and EHRs which can be used to better assist and provide patients with the proper resources and help reduce hospital cost and provide for a better treatment for the patient. Machine learning and predictive analytics are emerging more and more as data science and data analytics gains popularity. From our research, we suggest that emphasis on data preprocessing could result in a higher accuracy model. Emphasis on preprocessing can better help analyze results and derive conclusions more efficiently. Machine learning can be applied to different industries and organizations but machine learning algorithms along with predictive analytics can play a vital part for the healthcare industry. These techniques can help save cost, reduce failures and delays in medical settings and impact the healthcare industry tremendously.

#### Work cited

K.Watson, "Predictive Analytics in Healthcare", Deloitte Insights, 2019.

P. S. Kumar and S. Pranavi, "Performance analysis of machine learning algorithms on diabetes dataset using big data analytics," *2017 International Conference on Infocom Technologies and Unmanned Systems (Trends and Future Directions) (ICTUS)*, Dubai, 2017, pp. 508-513.

Marzyeh Ghassemi, Tristan Naumann, Peter Schulam, Andrew L Beam, and Rajesh Ranganath. Opportunities in machine learning for healthcare. *arXiv preprint arXiv:1806.00388*, 2018.

Ehlers, A. P., Roy, S. B., Khor, S., Mandagani, P., Maria, M., Alfonso-Cristancho, R., & Flum, D. R. (2017). Improved Risk Prediction Following Surgery Using Machine Learning Algorithms. *EGEMS (Washington, DC)*, 5(2), 3. doi:10.13063/2327-9214.1278

Sarwar, M. A., Kamal, N., Hamid, W., & Shah, M. A. (2018). Prediction of Diabetes Using Machine Learning Algorithms in Healthcare. *2018 24th International Conference on Automation and Computing (ICAC)*. doi: 10.23919/iconac.2018.8748992

Rojas, J., Carey, K., Edelson, D., Venable, L., Howell, M., & Churpek, M. (2018). Predicting Intensive Care Unit Readmission with Machine Learning Using EHR Data. *AnnalsATS*, 846-853.

Karhade, Aditya & Ogink, Paul & Thio, Quirina & Broekman, Marike & Cha, Thomas & Gormley, William & Hershman, Stuart & Peul, Wilco & Bono, Christopher & Schwab, Joseph. (2018). Development of machine learning algorithms for prediction of discharge disposition after elective inpatient surgery for lumbar degenerative disc disorders. *Neurosurgical Focus*. 45. 10.3171/2018.8.FOCUS18340.

A. Morton, E. Marzban, G. Giannoulis, A. Patel, R. Aparasu and I. A. Kakadiaris, "A Comparison of Supervised Machine Learning Techniques for Predicting Short-Term In-Hospital Length of Stay among Diabetic Patients," *2014 13th International Conference on Machine Learning and Applications*, Detroit, MI, 2014, pp. 428-431.

A. R. Al Taleb, M. Hoque, A. Hasanat and M. B. Khan, "Application of data mining techniques to predict length of stay of stroke patients," *2017 International Conference on Informatics, Health & Technology (ICIHT)*, Riyadh, 2017, pp. 1-5.

Tanuja, S., Acharya, D.U., & Shailesh, K. (2011). Comparison of Different Data Mining Techniques to Predict Hospital Length of Stay.

Veith, Nick & Steele, Robert. (2018). Machine Learning-based Prediction of ICU Patient Mortality at Time of Admission. 10.1145/3206098.3206116.

Wang, S., McDermott, M., Chauhan, G., Hughes, M. C., Naumann, T., & Ghassemi, M. (2019). Mimic-extract: A data extraction, preprocessing, and representation pipeline for mimic-iii. *arXiv preprint arXiv:1907.08322*.

Ma, N. L., Khataniar, S., Wu, D., & Ng, S. S. Y. (2014). Predictive Analytics for Outpatient Appointments. *2014 International Conference on Information Science & Applications (ICISA)*. doi: 10.1109/icisa.2014.6847449

Hosmer Jr, D. W., Lemeshow, S., & Sturdivant, R. X. (2013). *Applied logistic regression* (Vol. 398). John Wiley & Sons.

Services, E. M. C. E. (2015). *Data Science and Big Data Analytics: Discovering, Analyzing, Visualizing and Presenting Data*. Somerset: Wiley.

Gentimis, T., Ala'J, A., Durante, A., Cook, K., & Steele, R. (2017, November). Predicting hospital length of stay using neural networks on mimic iii data. In *2017 IEEE 15th Intl Conf on Dependable, Autonomic and Secure Computing, 15th Intl Conf on Pervasive Intelligence and Computing, 3rd Intl Conf on Big Data Intelligence and Computing and Cyber Science and Technology Congress (DASC/PiCom/DataCom/CyberSciTech)* (pp. 1194-1201). IEEE.

Larose, D. T., & Larose, C. D. (2014). *Discovering knowledge in data: an introduction to data mining*, second edition. New Jersey: John Wiley.

## **THE MULTI-INTELLIGENT AGENT GROUP DECISION SUPPORT SYSTEM (MIA-GDSS)**

Josephine Stanley-Brown, Virginia Commonwealth University, 301 W Main St., Richmond, VA 23284, 804-828-1595, [stanleybrowjb@vcu.edu](mailto:stanleybrowjb@vcu.edu) and  
Norfolk State University, 700 Park Ave., Norfolk, VA 23502  
Heinz Roland Weistroffer, Virginia Commonwealth University, 301 W Main St., Richmond, VA 23284, 804-828-1595, [hrweistr@vcu.edu](mailto:hrweistr@vcu.edu)  
Ramandeep Kaur Sandhu, Virginia Commonwealth University, 301 W Main St., Richmond, VA 23284, 804-828-1595, [sandhurk2@vcu.edu](mailto:sandhurk2@vcu.edu)

### **ABSTRACT**

The complexities of group decision making are significant, especially today with the size of data and the difficulty for groups to locate, access, filter, and integrate accurate and high-quality information. Additionally, the fact that different members have different levels of expertise and knowledge makes the process even more challenging. GDSSs assist group members with communication, decision analysis, and discussions; however, in their current state, they are becoming less and less effective and efficient. They can no longer just be standard support systems; they must integrate and offer users an element of (artificial) intelligence that can truly address the complex issues of the group decision-making process. So how can these issues be addressed? One solution might lie in the integration of intelligent software agents or intelligent agents. As such, this paper will propose a high-level conceptual framework called the Multi-Intelligent Agent Group Decision Support System (MIA-GDSS), which will attempt to address the question: How can multi-intelligent agents be used to make the group decision-making process more effective and efficient?

### **INTRODUCTION**

Group decision making involving complex problems in and of itself is a complex process. Because it involves more than one person, a consensus on how to address and solve problems becomes a complicated task. Moreover, because of the nature of, and the enormous amount of data (i.e., big data) that exist, it is becoming more and more difficult for groups to locate, access, filter, and integrate accurate and high-quality information in the decision-making process. Additionally, the fact that different members have different levels of expertise and knowledge makes the process even more challenging. Of course, conventional Group Decision Support Systems (GDSSs) are tools that have addressed some of these issues. In fact, according to Ito and Shintani (1997), there are three ways in which a GDSS can assist the group decision making process: 1. It allows for the exchange of information amongst members; 2. It reduces uncertainty by providing decision-modeling and techniques; and 3. It offers expert advice in the selection of rules to apply to problems during meetings. So how can a GDSS assist groups with obtaining and deciphering through large amounts of relevant data, as well as understanding each piece of the data for insight in the decision making process; especially when group members have different levels of expertise and knowledge? One way may be to integrate artificial intelligence in the form of intelligent agents, specifically, multi-intelligent agents into the GDSS. Intelligent agents are autonomous, learning and reasoning interactive softwares. That is, they are programs

capable of achieving objectives without human intervention for humans, for themselves, or for other agents. They can be complementary to humans by adapting similar skills (e.g., communication, learning and coordination) rather than just replacing humans (Wooldridge and Jennings, 1995). Intelligent agents can also interact and exchange information with one another within a system, known as a multi-intelligent agent system. In this ecosystem, each agent focuses on specific tasks making them more effective and efficient at achieving a cohesive objective. Wooldridge and Jennings (1995) categorized the capabilities of agents in the following ways: Autonomous, they can operate without human intervention; co-operative, they can cooperate with other agents to achieve objectives; reactive, they can respond to changes in their environment in a timely fashion; proactive, they can take initiative; and mobile, they can travel through computer networks with knowledge and data. Nwana (1996) further classified agents by topology using five categories: 1. mobility, they can move; 2. reasoning, they can be deliberative or reactive; 3. ideal and primary attributes, they have autonomy and the ability to learn and cooperate; 4. role, they can inform or manage; and 5. hybrid, they be a combination of or all of the above.

The objective of this paper is to answer the following question: How can multi-intelligent agents be used to make the group decision-making process more effective and efficient? This will be accomplished by proposing a high-level conceptual framework called the Multi-Intelligent Agent Group Decision Support System (MIA-GDSS).

To answer the question, this paper will proceed as follows, first the methodology and an overview on intelligent agents will be discussed, next the decision-making process and related works will be presented, followed by a discussion on the issues of the group decision-making process. Lastly, a novel high level, conceptual group decision support system framework called the Multi-Intelligent Agent Group Decision Support System (MIA-GDSS) will be presented, along with the evaluation, limitations, and conclusion.

## METHODOLOGY

This study follows the design science methodology presented by Hevner et al. (2004) as shown in Table 1. The purpose is to present an artifact, i.e., framework.

**Table 1.** Methodology

<b>Guideline</b>	<b>Activity</b>
Design as an Artifact	Design a Multi-Intelligent Agent Group DSS that assist users with data mining and data analytics for decision-making.
Problem Relevance	Review of the literature to reveal that a system such as the Multi-Intelligent Agent Group DSS does not exist and is needed.
Design Evaluation	Evaluate using an informed argument.
Research Contribution	Present a DSS for a group that utilizes intelligent agents in mining and analyzing large volumes and varieties of data.



Research Rigor	Utilize the concepts of intelligent agents, collaborative group decision-making, and Groupthink theory.
Design as a Search Process.	Mine and analyze big data for the purpose of making the group decision-making process more effective and efficient.
Communication of Research	Inform the research community via a paper.

### INTELLIGENT AGENTS (IA)

An intelligent agent (IA) is a subcategory of artificial intelligence. In essence, IAs are software or components of a system responsible for performing part of a programmatic process, making them capable of accomplishing tasks on behalf of their users. They can be described by using cognitive notions, such as knowledge, belief, intention, obligation (Shen et al. 1995, Wooldridge, 1995), and emotion (Bates, 1994). They also can be characterized in multiple ways: functionality, utility, or topology (Gilbert, 1997; Magedanz et al., 1996; Tweedale, 2007). IAs are autonomous, yet cooperative. They can communicate with not only their users, but the system resources and other agents when required to accomplish a task. Together they can work and collaborate with each other when a task is beyond the ability of a single agent (i.e., they can become a multi-agent). They are mobile and can transport themselves, as well as information, across one system to another to access remote resources. Magedanz et al., 1996 describes intelligent agents with the attributes shown in Table 2.

**Table 2.** Intelligent Agent Attributes

<i>Agent Attributes</i>	<i>Description</i>
Intelligence	Understands goals, tasks, preferences, and vocabularies appropriate for various domains.
Asynchronous	Executes tasks totally decoupled from its user or other agents.
Communication	Communicates with various system resources and users.
Cooperation	Exchanges knowledge and information with user, system, and other agents, which represents the prerequisite for multi-agent systems.
Mobility	Transports data and information through a network to remote sites, usually in a specific run-time environment.

### THE DECISION-MAKING PROCESS

The decision-making process is a multi-step process, as noted by many researchers: Tuckman (1965) offered a five-stage process which included forming, storming, norming, performing, and adjourning. Fisher (1970) offered orientation, conflict, emergence, and reinforcement. Tubbs (1995) modified Fisher's model by adding orientation, conflict, consensus, and closure. These models fall in line with Simon's well-known 4-phase model of intelligence design, choice, and implementation. Turban et al. (2011) combined Simon's model of the decision-making process in a clear and succinct list of the major tasks activities along with the process activities (See Table 3). Overall, a group's goal is to work

together to arrive at a common goal-oriented decision. Not a decision that meets one particular member, or even a subset (i.e., majority) of members. The group decision-making process requires that the members communicate, interact, deliberate, search for and collect information, ask questions, obtain answers, produce answers, and make decisions or solve problems as one collective unit.

**Table 3.** Activities in the Decision-making Process

<b>Simon's Model</b>	<b>Tasks activities</b>	<b>Process activities</b>
Intelligence	Identify problems Collect information Information sharing Identify decision criteria Prioritizing decision criteria	Brainstorming Nominal group techniques Voting Ranking Deliberation negotiation
Design	Find alternatives Evaluate alternatives Compare alternatives Prioritize alternatives	Brainstorming Delphi method Voting Ranking
Choice	Alternative selection Sensitivity analysis Implementation plan	Choice models Decision analysis Negotiation
Implementation	Selection of an alternative Meeting management	Polling Discussion groups

For the purpose of this study, we will focus only on the intelligence and design tasks activities for the proposed multi-intelligent agent group decision support system.

### RELATED WORKS

We will present works within the last ten years that focus on agents and group decision support systems. Although the studies utilize agents to make the group decision-making process more effective and efficient, none of the studies address the issues of big data and different levels of expertise of the members.

Significant studies have been conducted with the idea of agents either replacing or assisting users within the group decision support system environment. We review some of the studies within the last few years. Santos et al. (2009) proposed a multi-agent model that supports groups in the decision-making process. They attempt to use agents in the negotiation process. Specifically, they use a negotiator agent, an aggressor agent, a submissive agent, and an avoider agent based on the McCrae & John (1992) Five Factor Model that defines agents' personalities. Yu et al. (2009) proposed an intelligent agent model that analyzed and evaluated risk levels of credit applicants over pre-defined criteria. Their evaluation results produced by different intelligent agents were aggregated into a group consensus to support the final decision for decision-makers of credit-granting institutions.

Palomares et al. (2013) proposed a Web-based consensus support system that integrates the decision-makers' attitude regarding consensus. They focus on the importance of decision-makers reaching a consensus with regard to modifying their own preferences. In their study, a decision-maker can have three attitudes: pessimistic, indifferent and optimistic. In their system, a decision-maker who has an optimistic attitude, means that for her to reach an agreement is more important than her own preferences. This means that the group's options will be given more importance. They argue that an optimistic attitude helps to reach consensus while a pessimistic attitude hampers the achievement of a consensus. Recio-García et al. (2013) proposed a group decision support system where each decision-maker has an agent who fights with the other agents in order to obtain the best alternative for the group. The proposed negotiation model consists of the users' social factors, personality and trust in the negotiation process. The decision-maker's personality is represented by a number ranging from 0 to 1 where 0 means a very cooperative person and 1 a very selfish person. They conclude that the proposed model allows for the achievement of better satisfaction rates when compared to the standard "fully connected" group recommender.

Abraham et al. (2014) presented a study using Multi-attribute decision-making (MADM) techniques and data visualization methods in group decision-making processes as a way to help reach a consensus. They conclude that the use of MADM methods assist the group in reaching a consensus; moreover, they gain understanding on the use of visualization techniques which assist decision-makers in showing clients the reasons for why a proposal is made. Palomares and Martínez (2014a) proposed a system that helps decision-makers reach a consensus during urgent situations. They presented a visual decision support tool that can represent the experts' preferences. This tool is based on Self-Organizing Maps and consists of a two-dimensional visual representation that allows perception of the levels of agreement/disagreement. They developed an experiment to reveal the usefulness of the proposed tool. They also revealed that the proposed tool can help decision-makers reach consensus more easily, as well as to have a better view of the current status of the decision process.

Palomares and Martínez (2014b) proposed a semi supervised consensus support system (CSS) using a multiagent system paradigm with the goal of overcoming difficulties associated with managing large groups of experts and the need for constant human supervision. To minimize the need for experts' interactions with the system, they developed a strategy that allowed the experts to express their individual concerns. They developed three different profiles: sure profile, unsure profile and neutral profile. The sure profile represents the experts that are very confident about their preferences. As such, they do not intend to change them. The unsure represents experts that want to achieve a consensus but are unsure about their opinions. The neutral, represent the experts that want to achieve a consensus and are moderately sure about their opinions. They conducted a case study of several experiments with the intent of understanding the different evolution of the degree of consensus between the proposed semi supervised CSS and a full-supervised CSS. They determined that within their proposed system it was possible to

minimize the need for expert human supervision and that their proposal helps to achieve high levels of consensus faster than the full-supervised CSS.

### **GROUP DECISION MAKING ISSUES**

“Two heads are better than one” as it is said. If so, then groups have more informational and motivational resources, and therefore probably can outperform individuals. However, there are multiple issues that hinder effective and efficient decision-making when multiple decision-makers are involved (i.e., group members). Members may feel an obligation to go along with the other members in the decision simply to appear as a “team” player even when the decision is not the best. Members may have difficulties mining and managing large amounts of data relevant to the decision-making process, and/or members may lack necessary knowledge and/or skills necessary to make the best decision. Conceivably some or all of these issues may contribute to a group not making the best decision possible as discussed below.

#### **Groupthink Theory**

Janis (1972) developed a theory named Groupthink, which is describe as faulty decision making that can occur in groups as a result of forces that bring a group together (group cohesion). By design because of the nature of groups and how they make decisions, the concept of Groupthink is very relevant. In fact, Groupthink causes the following group decision making problems:

- Inadequately considering all alternatives in order to maintain unanimity
- Poor examination of decision objectives
- Failure to properly evaluate the risks of the chosen solution alternative
- Information searches that are insufficient or biased

As discovered by Janis (1972), the desire for group conformity and unanimity essentially overrides the need to make effective decisions. This is where the usage of intelligent agents may assist group members in making better decisions. Unlike humans, intelligent agents are independent, unbiased actors that can interact with the users by receiving user specifications and delivering results. They can access large amounts of heterogeneous sources of collections of information, filter through large amounts of data/information and determine all alternatives relevant to a decision, as well as determine and resolve information conflicts and aggregate appropriate information.

#### **Big Data**

Today, because of the volume of big data, it is challenging for IT professionals and managers to decipher it and analyze it. Moreover, as the name implies, it is not only the volume that makes the understanding of big data a challenge, but the variety (structured, semi-structured, and unstructured), velocity (speed of the data coming from various sources), variability (inconsistency of data flow, especially with the inclusion of social media), complexity (linking, matching, cleansing and transforming of the data across

systems coming from various sources), and value (determining the importance of the data) that also add to this issue (Katal, et al. 2013).

As such, there are two main challenges for group decision making as it relates to big data: The handling of the data effectively and efficiently and the filtering of the most important data from all the data collected so as to add value to the organization, i.e., assist with making good decisions (Katal, et al. 2013). Unlike humans, intelligent agents are independent actors that can interact with the users by receiving user specifications and delivering results. They can filter through large amounts of data/information and determine all alternatives relevant to a decision.

### **Group Members' Level of Knowledge and Expertise**

The experience, knowledge, and expertise needed in organizations to solve problems and make decisions most times are carried out in groups. Often it is these groups that are formed with the explicit objective of bringing together people who are or are expected to become experts in performing specific aspects of the work in the organization. However, knowledge and expertise are heterogeneously distributed with the groups such that some members will become more of an expert in the performance of a particular tasks over others, given the differences in experience, training, education, and natural ability. As such, groups deal with the challenge of identifying their more expert members and giving greater weight to the advice, suggestions, and opinions of the more expert members in solving problems or making decisions (Bunderson, 2003).

Intelligent agents, as discussed, have the abilities to help counter the issues discussed. As shown in Table 4, they are not subject to Groupthink because they are independent and not influenced by other agents as well as they can mine, determine, examine, and consider the important alternatives with respect to the decision-making process. Unlike humans who have different expertise and knowledge bases, all intelligent agents involved can have a high level of expertise and knowledge in a desired area.

**Table 4.** Issues with Group Decision Making and Advantages of Intelligent Agents (Sycara et al. 1996)

<i>Issues with Group Decision Making</i>	<i>Advantages Intelligent Agents</i>
Inadequately considering all alternatives in order to maintain unanimity due to Groupthink	Intelligent agents are independent actors that can interact with the users by receiving user specifications and delivering results. They can filter through large amounts of data/information and determine all alternatives relevant to a decision.
Poor examination of decision objectives due to lack of knowledge/expertise	Intelligent agents can identify and interpret importance of information-seeking sub-goals/objectives.

Failure to properly evaluate the risks of the chosen solution alternative due to lack of knowledge/expertise	Intelligent agents can retain useful information from their interactions as training examples and use various machine-learning techniques to adapt to new situations and improve performance.
Information searches that are insufficient or biased due to big data	Intelligent agents are unbiased in their functionality. They can access large amounts of heterogeneous sources of collections of information, determine and resolve information conflicts, and aggregate appropriate information.

### **PROPOSED MULTI-INTELLIGENT AGENT GROUP DECISION SUPPORT SYSTEM (MIA-GDSS)**

From the studies discussed, none focused on the issues presented from the theory of Groupthink, big data and various levels of knowledge and expertise. As such, the proposed Multi-Intelligent Agent Group Decision Support System (MIA-GDSS) provides a solution not explored, yet relevant to making the group decision making process more effective and efficient (See Figure 1).

Below we will discuss the MIA-GDSS and its three main intelligent agents: the interaction agent whose functions are to provide an interface between the group members, shared knowledge, and the system's components so that collaboration can take place; the coordinator agent whose functions are to facilitate and transport knowledge between members' interaction agents and the knowledge support agent, to manage the progress made by the support agent, as well as to notify members of the support agent's discovery, and to control all communications, and the knowledge support agent whose function is to discover knowledge.

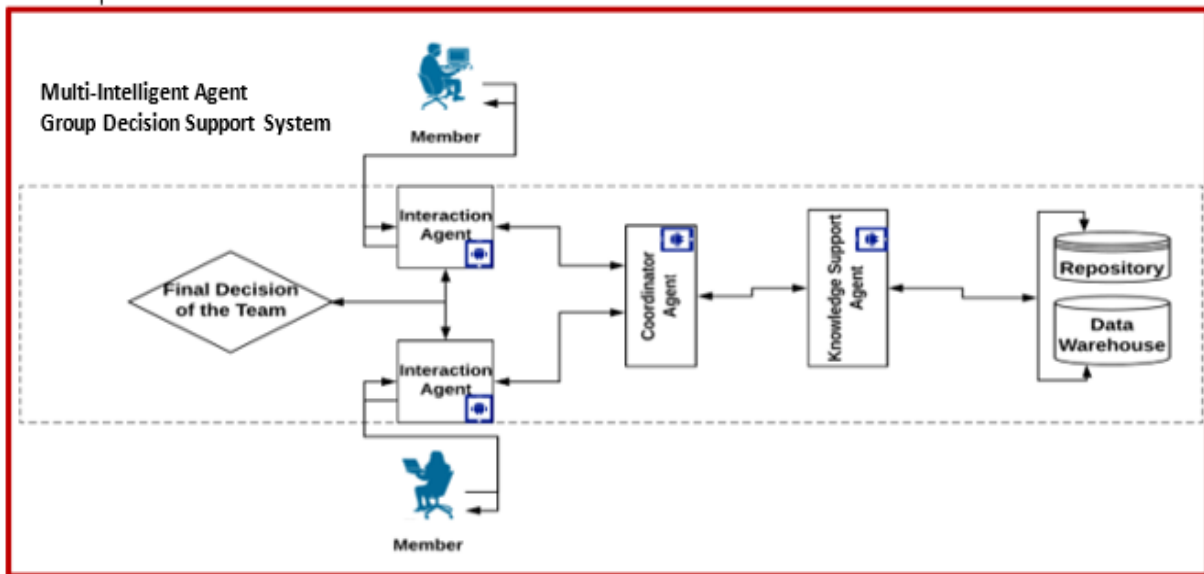
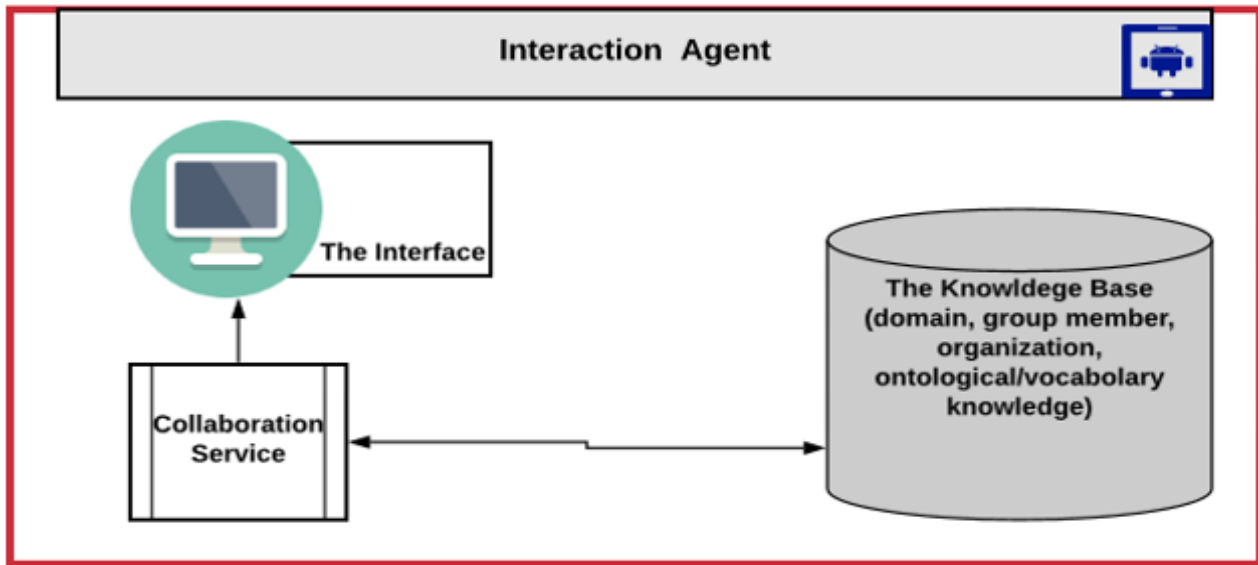

**Figure 1.** Proposed Multi-Intelligent Agent Group Decision Support System (MIA-GDSS)

### The Interaction Agent

The interaction agent allows the interaction between the group members and the other components of the IMAT-DSS. It has three components shown in Figure 2. The interface allows for the initial interaction and communications between the group member and the MIA-GDSS. The collaboration service manages the interactions with the group members like accepting request for a task of the knowledge support agent while the coordinator agent manages the communications. The relevant knowledge like domain knowledge, past organization knowledge, and ontological knowledge is stored in the local knowledge base. All the components are controlled by the collaboration service agent.

The function of the interaction agent is relevant to the decision-making process in that it assists the group member with seeing the other group members' priorities as well as the opportunity to share her own priorities with the other group members. Additionally, group members can request task to the support knowledge agents for knowledge discovery. The interaction agent can then share the request with the collaborator agent and interpret the discovery results.



**Figure 2.** Interaction Agent

### The Coordinator Agent

The coordinator agent assists with managing and controlling the functions of all the agents in the MIA-GDSS. The three components of the coordinator agent are shown in Figure 3. The support knowledge agent, the interaction agent, and the repository make available support for focused reasoning.

The coordinator agent is responsible for deciding when to use the knowledge support agents, for managing and analyzing the request through the local knowledge. It also initiates when the knowledge support agent will perform requested tasks. Additionally, it facilitates the discovered knowledge from the knowledge support agent, stores the knowledge into the repository for future use and forwards the relevant knowledge to the group member. Lastly, it synchronizes the time between the collection and progress of the support knowledge agent through notification to the group member alerting them that knowledge has been discovered.

The function of the coordinator agent is relevant to the decision-making process in that it manages activities between the group members, between the group members and the agents, and the repository for knowledge sharing.



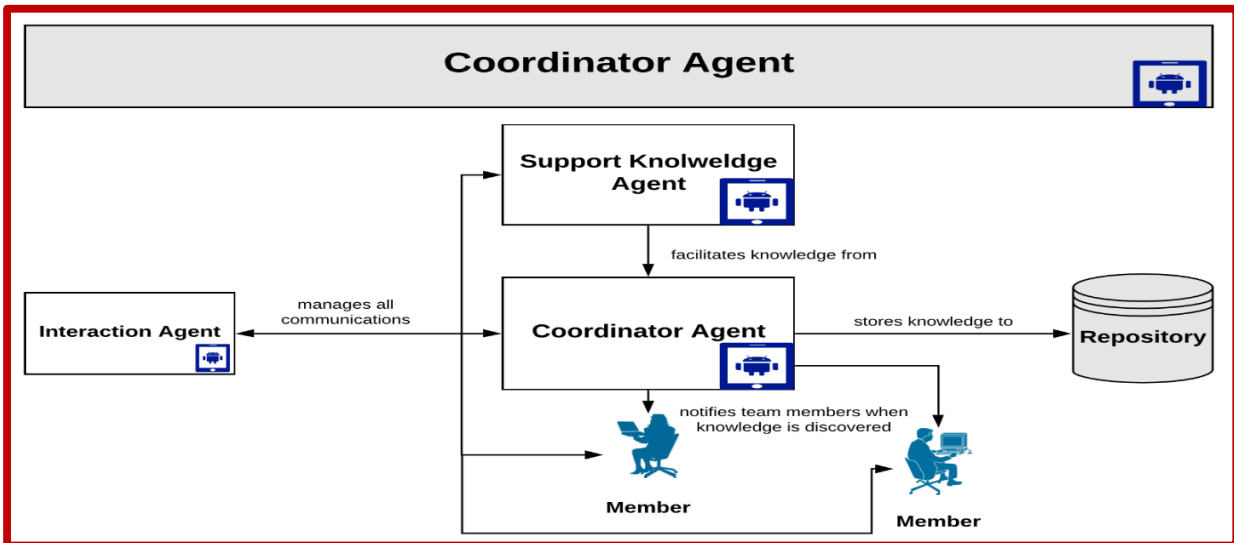

**Figure 3.** Coordinator Agent

### The Knowledge Support Agent

During the intelligence phase, group members identify the problem or opportunity and collect relevant information. The collection task can be challenging when members are not knowledgeable or do not have a certain level of expertise in the area of data and text mining or analytics. In this case, an intelligent agent can be very effective and efficient regarding the tasks of finding, sharing, and analyzing information.

In the design phase, group members need to generate potential alternative courses of actions. There are multiple ways to accomplish this task; however, it is very challenging for group members because of the aforementioned reasons associated with Groupthink (e.g., inadequately considering all alternatives in order to maintain unanimity) and big data (e.g., too much data to analyze and understand). Again, intelligent agents can be very effective and efficient regarding these tasks also.

The role of the knowledge support agent is to discover patterns about the topic, providing support in the decision-making process. The knowledge support agent's consist of four components shown in Figure 4. The MIA-GDSS interface component manages the communication between the knowledge support agent and the coordinator agent. Once the knowledge support agent receives a message, the MIA-GDSS interface translates the message into the local format based on the local vocabulary/ontology. Conversely, when the knowledge support agent sends a message out, the MIA-GDSS interface translates it into common format first, then sends it to the coordinator agent. To carry out the mining task, the domain knowledge and other local knowledge is retained in the knowledge base, while the data interface component serves as the interface to external data sources.

The function of the knowledge support agent is relevant to the decision-making process in that it discovers hidden relationships, dependencies, and patterns within the data sources, which provides valuable information to the group decision-makers in finding a solution.

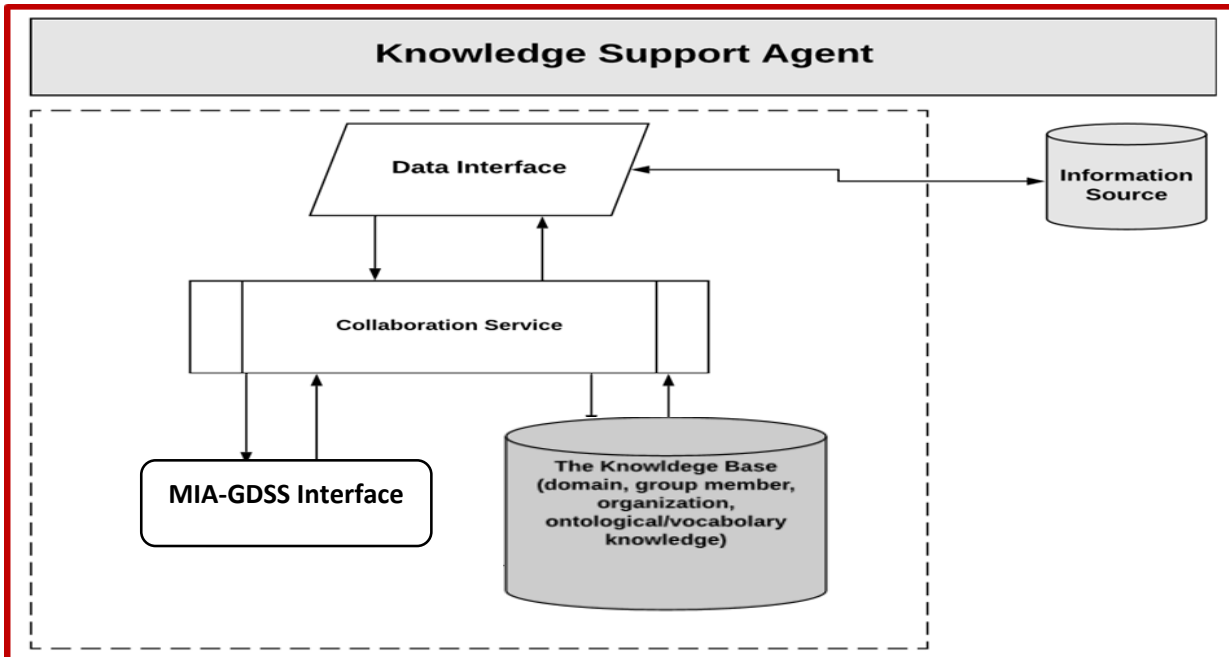

**Figure 4.** Knowledge Support Agent

**EVALUATION**

Hevner et al. (2004) states that the descriptive informed argument evaluation method is appropriate and acceptable for artifacts (See Table 5).

**Table 5.** Informed Arguments for each agent in Intelligent Multi-Agent Group Decision Support System (IMAT-DSS)

<b>Agent</b>	<b>Justification</b>
Interaction Agent	It allows for the interaction between the group members and the other components. -The subcomponent, interface allows for the initial interaction and communications between the group member and the MIA-GDSS. -The collaboration service manages the interactions with the group member, for example, accepting request for a task of the knowledge support agent.
The Coordinator Agent	It assists with managing and controlling the functions of all the agents in the MIA-GDSS. It is responsible for deciding when to use the knowledge support agents, for managing and analyzing the request through the local knowledge base. It also

	initiates when the knowledge support agent will perform requested tasks.
The Knowledge Support Agent	<p>The role of the knowledge support agent is to discover patterns about the topic, providing support in the decision-making process.</p> <p>The knowledge support agent's consist of four components.</p> <ul style="list-style-type: none"> <li>-The MIA-GDSS interface component manages the communication between the knowledge support agent and the coordinator agent. Once the knowledge support agent receives a message, the MIA-GDSS interface translates the message into the local format based on the local vocabulary/ontology.</li> <li>-When the knowledge support agent sends a message out, the IMAT-DSS interface translates it into common format first, then sends it to the coordinator agent. To carry out the mining task, the domain knowledge and other local knowledge is retained in the knowledge base, while the data interface component serves as the interface to external data sources.</li> <li>-The function of the knowledge support agent is relevant to the decision-making process in that it discovers hidden relationships, dependencies, and patterns within the data sources, which provides valuable information to the group decision makers in finding a solution.</li> </ul>

### **LIMITATIONS AND CONCLUSION**

The complexities of group decision making are significant, especially today with the size of data and the difficulty for groups to locate, access, filter, and integrate accurate and high-quality information. Additionally, the fact that different members have different levels of expertise and knowledge makes the process even more challenging. Conventional Group Decision Support Systems (GDSSs) have not addressed these issues and as such, are becoming less and less effective and efficient in their current state. They can no longer be standard models; they must integrate and offer users an element of (artificial) intelligence that can truly address the complex issues of the group decision-making process.

The goal of this paper is to offer a partial solution to the problem and answer the question: How can multi-intelligent agents be used to make the group decision-making process more effective and efficient? The authors acknowledge, however, that the solution offered is just a high-level conceptual one. To know truly if it is a solution would require the actual design and instantiation of the artifact, and the evaluation of such a system to determine if it is a valid answer to a complex problem. Nonetheless, it is the hope of the authors that the proposed framework sparks further investigation by researchers and provides insight for practitioners.

## REFERENCES

- [1] Abraham, K., Flager, F., Macedo, J., Gerber, D., & Lepech, M. (2014, July). Multi-attribute decision-making and data visualization for multi-disciplinary group building project decisions. Working Paper Series, Proceedings of the Engineering Project Organization Conference, Winter Park, CO.
- [2] Bates, J. (1994). The role of emotion in believable agents. *Communications of the ACM*, 37(7), 122-125.
- [3] Bunderson, J. (2003). Recognizing and Utilizing Expertise in Work Groups: A Status Characteristics Perspective. *Administrative Science Quarterly*, 48(4), 557-591. doi:10.2307/3556637
- [4] Desanctis, G., & Gallupe, R. B. (1987). A foundation for the study of group decision support systems. *Management science*, 33(5), 589-609.
- [5] Fisher, B. A. (1970). Decision emergence: Phases in group decision-making. *Communications Monographs*, 37(1), 53-66.
- [6] Forsyth, D. R. (2014). *Group dynamics* (6th ed.). Belmont, CA: Wadsworth Cengage Learning.
- [7] Gilbert, D. (1997). *Intelligent agents*. IBM Intelligent Agent Center.
- [8] Ito, T., & Shintani, T. (1997). Persuasion among agents: An approach to implementing a group decision support system based on multi-agent negotiation. In *international joint conference on artificial intelligence* (Vol. 15, pp. 592-599). Lawrence Erlbaum Associates Ltd.
- [9] Hevner, A., March, S., Park, J., & Ram, S. (2004). Design Science in Information Systems Research. *MIS Quarterly*, 28(1), 75-105. doi:10.2307/25148625
- [10] Katal, A., Wazid, M., & Goudar, R. H. (2013, August). Big data: issues, challenges, tools and good practices. In *2013 Sixth international conference on contemporary computing (IC3)* (pp. 404-409). IEEE.
- [11] Lin, R., Kraus, S.: Can automated agents proficiently negotiate with humans? *Communications of the ACM* 53(1), 78-88 (2010).
- [12] McCrae, R. R., & John, O. P. (1992). An introduction to the five-factor model and its applications. *Journal of personality*, 60(2), 175-215.
- [13] Magedanz, T., Rothermel, K., & Krause, S. (1996, March). Intelligent agents: An emerging technology for next generation telecommunications?. In *Proceedings of IEEE INFOCOM'96. Conference on Computer Communications* (Vol. 2, pp. 464-472). IEEE.

- [14] Palomares, I., Rodríguez, R. M., & Martínez, L. (2013). An attitude-driven web consensus support system for heterogeneous group decision making. *Expert Systems with Applications*, 40(1), 139-149.
- [15] Palomares, I., & Martínez, L. (2014a). Low-dimensional visualization of experts' preferences in urgent group decision making under uncertainty. *Procedia Computer Science*, 29, 2090-2101.
- [16] Palomares, I., & Martínez, L. (2014b). A semisupervised multiagent system model to support consensus-reaching processes. *IEEE Transactions on Fuzzy Systems*, 22(4), 762-777.
- [17] Recio-García, J. A., Quijano, L., & Díaz-Agudo, B. (2013). Including social factors in an argumentative model for group decision support systems. *Decision Support Systems*, 56, 48-55.
- [18] Santos, R., Marreiros, G., Ramos, C., Neves, J., & Bulas-Cruz, J. (2009, May). Using personality types to support argumentation. In *International Workshop on Argumentation in Multi-Agent Systems* (pp. 292-304). Springer, Berlin, Heidelberg.
- [19] Shen, W., & Barthes, J. P. A. (1995, June). DIDE: A Multi-Agent Environment for Engineering Design. In *ICMAS* (pp. 344-351).
- [20] Sycara, K., Pannu, A., Williamson, M., Zeng, D., & Decker, K. (1996). Distributed intelligent agents. *IEEE expert*, 11(6), 36-46.
- [21] Tubbs, S. L. (2012). A systems approach to small group interaction.
- [22] Tuckman, B. W. (1965). Developmental sequence in small groups. *Psychological bulletin*, 63(6), 384.
- [23] Turban, E., Liang, T. P., & Wu, S. P. (2011). A framework for adopting collaboration 2.0 tools for virtual group decision making. *Group decision and negotiation*, 20(2), 137-154.
- [24] Tweedale, J., Ichalkaranje, N., Sioutis, C., Jarvis, B., Consoli, A., & Phillips-Wren, G. (2007). Innovations in multi-agent systems. *Journal of Network and Computer Applications*, 30(3), 1089-1115.
- [25] van Heck, E., & Ketter, W. (2011, May). Challenges for Software Agents Supporting Decision-Makers in Trading Flowers Worldwide. In *International Conference on Web Information Systems and Technologies* (pp. 32-39). Springer, Berlin, Heidelberg.
- [26] Wooldridge, M., & Jennings, N. R. (1995). Intelligent agents: Theory and practice. *The knowledge engineering review*, 10(2), 115-152.
- [27] Yu, L., Wang, S., & Lai, K. K. (2009). An intelligent-agent-based fuzzy group decision making model for financial multicriteria decision support: The case of credit scoring. *European journal of operational research*, 195(3), 942-959.

**Data Analytics and  
Statistics Instruction  
(DASI) (Invited sessions  
only) - Abstracts**

## **AACSB Accreditation Contributes More to the Cost of Education than the Quality of Education: True or False?**

---

Regular Session

---

***Dr . Bob Andrews*** <sup>1</sup>, ***Dr . Gary Hackbarth*** <sup>2</sup>, ***Dr . Suzie Smith*** <sup>3</sup>, ***Dr . Kellie Keeling*** <sup>4</sup>

*1. Virginia Commonwealth University , 2. Valdosta State University , 3. Presbyterian College , 4. University of Denver*

To begin the process of answering this question, the session will engage the attendees in brainstorming for the first two steps of the CRISP DM process: Business Understanding & Data Understanding. Arriving at the right decision depends on getting the right data. Problem formulation and identifying proper data may be the most difficult to teach. To obtain a broad understanding of a process it is important to engage a group of people with a variety of experiences with the process. During this session the attendees and session leaders will identify variables that can be used to measure the cost of AACSB Accreditation and variables to measure the improvement of quality of the education provided to students as a result of the AACSB Accreditation process.

## **Analytics & Data Science Difference and “Using Software” in Business Analytics Courses**

---

Regular Session

---

***Dr . Bob Andrews*** <sup>1</sup>, ***Dr . Jeff Camm*** <sup>2</sup>, ***Dr . Melissa Bowers*** <sup>3</sup>, ***Mr . David Stephan*** <sup>4</sup>

*1. Virginia Commonwealth University , 2. Wake Forest University , 3. University of Tennessee , 4. Two Bridges Instructional Technology*

Session addresses two topics. 1. **What is the difference in Analytics and Data Science?** This talk summarizes our findings based on a review of academic (masters) programs as well as job ads in analytics and data science. We also discuss who should care and why. 2. **Misconceptions About “Using Software” in Business Analytics Courses** A generation ago, shapers of IS courses often spent much time disagreeing about which software to use in their courses. In hindsight, differing mental models shaped perceptions about what “using software” meant and clouded such discussions. Comments at DSI 2019 DASI sessions suggest that a similar “cloudiness” impedes discussions that seek to define business analytics courses. This session provides a basis for avoiding such cloudiness and explains the assertion that saying “my analytics course uses X,” where X is a specific piece of software, is always an incomplete specification.



# Dealing with Challenging Data, Adaptive Learning Course Design & Statistical Knowledge for Analytics

---

Regular Session

---

*Dr . Bob Andrews<sup>1</sup>, Dr . Ping Wang<sup>2</sup>, Dr . Zhiwei Zhu<sup>3</sup>, Dr . Denise Benton<sup>3</sup>, Mrs . Wilma Andrews<sup>1</sup>*

*1. Virginia Commonwealth University , 2. Texas A&M University at Galveston , 3. University of Louisiana at Lafayette*

The first presentation will introduce R packages with recent advancements of regression-based estimation methods to analyze challenging data such as unobtrusively collected “digital exhaust” data. The second presentation will discuss how combining Open Educational Resources (OER) and the adaptive platform can make it possible to adopt a variety of course materials to use a data-driven approach to instruction and remediation, which can differentiate individual learning pathways to meet the needs of specific learners. The third presentation will take a critical look at the typical topics in introductory statistics classes from the perspective of the knowledge needed for business intelligence and business analytics.. It will also address how to use new features in PowerPoint to effectively communicate analysis results.

## Experiences with Teaching Coding with R and Python to Business Students

---

Regular Session

---

***Dr . Bob Andrews <sup>1</sup>, Dr . Leslie Hendrix <sup>2</sup>, Dr . Cheryl Aasheim <sup>3</sup>***

*1. Virginia Commonwealth University , 2. University of South Carolina , 3. Georgia Southern University*

Deciding whether to teach coding in R or Python to business students can lead to a heated debate from both sides. This session features two experiences, one with R and one with Python. At the Darla Moore School of Business at the University of South Carolina, all undergraduate business students learn basic programming skills in R, in addition to Excel. This talk discusses why and how we teach coding to students who have no coding experience and why we think it is important. We will also discuss student and faculty sentiment toward this new initiative and how R programming is being woven throughout the rest of the curriculum. For example, based on student requests, students in our data visualization course are learning to run R scripts in Power BI. For teaching Python coding for Analytics in an IT Program at Georgia Southern University, the presentation will discuss the use of Python as the core programming course as well as it's use for analytics. The presentation will focus on how the course fits in the curriculum, pros and cons of using Python, materials used, course structure, the libraries and skills taught and lessons learned from the first offering of the course.

## Helping students learn that analyzing model residuals helps them understand the data better

---

Regular Session

---

Mr . Kevin Potcner <sup>1</sup>

1. JMP

Most traditional statistics courses emphasize that analyzing model residuals is necessary in order to validate certain assumptions – normality, homogeneity of variance, etc. Since these assumptions are primarily about ensuring that the underlying mathematical framework of a statistical procedure is valid, students often see this step as something necessary but not tremendously insightful.

Using examples that focus more on how the analysis of residuals can uncover interesting features in the data, students are more likely to see why doing so helps them understand the data better and even the model itself. In addition, many of the new modeling techniques being taught today don't rely on those traditional model assumptions. For these techniques, it's quite natural to shift the focus towards using residuals as a means to gain better understanding of the data rather than to simply verify that one can trust the analysis results.

In this talk, the audience will see some examples that they can use in the classroom to help students appreciate the value that exploring the residuals has in doing a thorough data analysis.

## Report on Efforts to Expand Course and Degree Offerings to Satisfy Increased Demand for Analytics Knowledge

---

Regular Session

---

***Dr . Bob Andrews <sup>1</sup>, Dr . Alan Russell Cannon <sup>2</sup>, Dr . Mary M. Whiteside <sup>2</sup>, Dr . Stephen W. Custer <sup>1</sup>, Dr . Barbara J. Hoopes <sup>3</sup>***

*1. Virginia Commonwealth University , 2. University of Texas at Arlington , 3. Virginia Tech*

Three universities report on their efforts to expand course offerings and degree programs to address the demand for graduates with analytics knowledge. The University of Texas at Arlington switched from a single required junior level statistics course to a sophomore level course followed by an advanced junior level class and is developing a follow on third course. Virginia Commonwealth University moved from a Decision Sciences concentration in an MS in Business degree with traditional evening courses to a Master of Decision Analytics Program with a Traditional Track and a Professional Track offered on weekends. Virginia Tech currently has several different graduate degrees with some analytics focus. Their report will be on evaluating the possibility of launching a new graduate degree in Business Analytics

# Residual Analysis for Better Data Understanding & Data Mining with Microsoft Azure Machine Learning Studio

---

Regular Session

---

***Dr . Bob Andrews*** <sup>1</sup>, ***Mr . Kevin Potcner*** <sup>2</sup>, ***Dr . Denise Benton*** <sup>3</sup>, ***Dr . Zhiwei Zhu*** <sup>3</sup>

*1. Virginia Commonwealth University , 2. JMP , 3. University of Louisiana at Lafayette*

Session has two major components. The first uses examples to show how the analysis of residuals for a prediction model can uncover interesting features in the data. Audience members can use these examples in their classroom to help students appreciate how exploring the residuals can provide a more thorough understanding of the data. The second tells of the experience of Using Microsoft Azure Machine Learning Studio for data mining in an intermediate level business analytics course. This will include a demonstration of accessing ML Studio, exploring data using the application, running the data mining algorithms and viewing the results.

# Teaching Data Visualization: Course Design, Use of Tableau & Grading Rubric for Projects

---

Regular Session

---

***Dr . Bob Andrews*** <sup>1</sup>, ***Dr . Barry Wray*** <sup>2</sup>, ***Dr . Suzie Smith*** <sup>3</sup>, ***Prof . Maureen Petkewich*** <sup>4</sup>, ***Dr . Rebecca Scott*** <sup>5</sup>

*1. Virginia Commonwealth University , 2. University of North Carolina Wilmington , 3. Presbyterian College , 4. University of South Carolina , 5. University of North Carolina, Wilmington*

Session addresses important aspects of teaching data visualization.

**Course Design:** Course structure is very much dependent on the unique area for which it is designed. Focus will be on design issues for visualization courses taught for students in both undergraduate and graduate programs in Business Analytics.

**Teaching with Tableau:** Proficiency in Data Analytics includes creating compelling visualizations and telling the right story well with data. This presentation offers insights on these important topics using Tableau as the primary platform for instruction.

**Grading Rubric for Projects:** Will present a rubric for grading data visualization projects using Power BI along with the thinking behind the different categories and weighting. Will finish with an interactive discussion of the criteria with the audience and seek their ideas on grading interactive dashboards

## Using Advanced Analysis Methods for Better Understanding: Cluster Analysis, Logistic Regression, & Classification Trees

---

Regular Session

---

***Dr . Bob Andrews <sup>1</sup>, Dr . Rose Sebastianelli <sup>2</sup>, Dr . Nabil Tamimi <sup>2</sup>, Mr . David Stephan <sup>3</sup>***

*1. Virginia Commonwealth University , 2. University of Scranton , 3. Two Bridges Instructional Technology*

Session begins with an example of how cluster analysis can be used to facilitate identification of the “leaders” and “laggards” among the S&P 500 with respect to transparency on environmental and social practices and performance. Secondly, there is a discussion of how logistic regression and classification trees are a natural pair of tools that can help students and analysts better understand the interplay between explanatory and predictive analytics models.

**Data Analytics and  
Statistics Instruction  
(DASI) (Invited sessions  
only) - Papers**



## **Report on Efforts to Expand Course and Degree Offerings to Satisfy Increased Demand for Analytics Knowledge**

Session Chair & Presenter: **Robert L. Andrews**  
Virginia Commonwealth University  
Emeritus Professor, School of Business  
randrews@vcu.edu

**Alan Russell Cannon**  
University of Texas at Arlington  
acannon@uta.edu

**Mary M. Whiteside**  
University of Texas at Arlington  
whiteside@uta.edu

**Stephen W. Custer**  
Virginia Commonwealth University  
Director Decision Analytics Professional Track  
swcuster@vcu.edu

**Barbara J. Hoopes**  
Virginia Tech  
Academic Director – VT MBA Programs  
bhoopes@vt.edu

### **Abstract**

Three universities report on their efforts to expand course offerings and degree programs to address the demand for graduates with analytics knowledge. The University of Texas at Arlington switched from a single required junior level statistics course to a sophomore level course followed by an advanced junior level class and is developing a follow on third course. Virginia Commonwealth University moved from a Decision Sciences concentration in an MS in Business degree with traditional evening courses to a Master of Decision Analytics Program with a Traditional Track and a Professional Track offered on weekends. Virginia Tech currently has several different graduate degrees with some analytics focus. Their report will be on evaluating the possibility of launching a new graduate degree in Business Analytics

**University of Texas at Arlington** report will discuss: 1) mapping out the transition, as our college's undergraduate population gradually turns over from the "one course" to the "two course" paradigm; 2) deciding on the content to be visited in that second course; 3) exploring how that third course should (or will) be configured; and 4) choosing a software approach for one, more or all of these courses.

**Virginia Commonwealth University** began with a Decision Sciences concentration in an M.S. in Business with evening classes oriented toward serving working students. We ended with a STEM degree, Master of Decision Analytics (M.D.A.) with two tracks offered in two different

formats. The Traditional Track uses traditional 3-credit-hour courses with a 5-course required core and five electives that allow the student flexibility to specialize in an area of interest. The Professional Track courses are on weekends similar to our EMBA program. This track requires previous professional experience in addition to an undergraduate degree. A cohort of students move through four semesters of coursework, which allows for better coaching in the areas of communication and teamwork.

### **Another Analytics Graduate Degree Program? What Are They Thinking?**

The **Virginia Tech** Pamplin College of Business is considering launching another graduate degree in Business Analytics, likely online. However, the deliberations have been deep, considering that 1) we already offer a Master of Science in Business Administration in Business Analytics at the Blacksburg campus, 2) Virginia Tech at large offers several Analytics-based graduate degrees out of other departments, both online and in the metro-Washington, DC region, where this degree would be based, and 3) perhaps we have missed the bubble of interest in Analytics degrees anyway. But we also believe that Business Analytics education is adequately differentiated from the statistics and computer science/engineering-based degrees, there still seems to be adequate demand, especially in the online population, and Virginia Tech can seemingly build on their success with their online Master of Information Technology degree program. So, DOES the world really need another Business Analytics degree program? What exactly would it look like, how can we compete in a saturated market space, and how can we design it to maximize the likelihood of its long-term success? There are both internal (university) and external (state) hurdles to conquer in the process.

**Healthcare, Public Sector  
and Not for Profit  
Management - Abstracts**

# **A Case Study for Enabling a Non-Profit Organization to Help Adult Artists with Cognitive Disabilities through a Multisensory Environment (MSE) of Virtual Reality (VR)**

---

Oral

---

***Dr . James Lawler <sup>1</sup>***

*1. Pace University*

The descriptive findings of this paper highlight comfortability as a foundation for non-profit organizations to further invest in multisensory environments of virtual reality for artistic higher-functioning people with developmental and intellectual disabilities (IDD).

## COMMON COMPETENCIES FOR HEALTHCARE MANAGERS: A COMMUNITY PERSPECTIVE

---

Oral

---

***Dr . Matthew Kolakowski <sup>1</sup>, Dr . Sherif Ebrahim <sup>2</sup>, Dr . Janice Pittman <sup>3</sup>***

*1. Valdosta State University , 2. Tulane University , 3. Union University*

Today's healthcare environment requires an examination of what it means to be a fully competent leader. As a result, an upsurge in interest in healthcare management competencies has resulted. The present study utilizes a diverse group of informants as participants: health management practitioners, multi-disciplinary faculty groups, and health service consumers. Using the competency directory published by the Healthcare Leadership Alliance (HLA), this study examined which traits are essential in the provision of quality healthcare services. Additionally, demographic questions were used from the American Health Values Survey to prevent ontological oscillation. Using survey data collected from 139 respondents, this study reveals that leadership was the only statistically significant competency. Implications for the practice of healthcare management are discussed.

## Designing Firm Strategies with Obesity Policy Research

---

Oral

---

*Dr . Sajeesh Sajeesh <sup>1</sup>, Dr . Ozgur Araz <sup>1</sup>, Dr . Terry Huang <sup>2</sup>*

*1. University of Nebraska-Lincoln , 2. City University of New York*

Public health agencies have designed and implemented interventions and policies specifically targeting individuals in the lower socio-economic strata. These policies have shown positive effects on individuals nutrition and physical activity practices, but food producers have been challenged with this changing policy environment and dynamics in the marketplace in which there have been some shifts in consumer trends. Recently, there is increasing interest in food industry for strategies that are responsive to these changing trends. The objective of this study is to build an analytical model to understand firms' competitive strategies on product positioning and pricing in the market and derive insights on the interactions of firm strategies and (perceived) impact of public health policies. In such a context, considered questions are: (i) Should firms offer similar or very different healthful offerings? and, (ii) How should firms' positioning strategies change as consumers' perceptions of healthful messaging and perceptions on taxation change? We formulate a duopoly market setting and solve for equilibrium prices and positioning sequentially using backward induction in order to answer these two important questions.

## Emergency! The ED Simulation Game

---

Oral

---

***Dr . Craig Froehle <sup>1</sup>, Dr . Elham Torabi <sup>2</sup>***

*1. University of Cincinnati , 2. James Madison University*

Attendees will participate in a demo of Emergency!, a cooperative, simulation-based, educational game based on an actual Emergency Department. Emergency! helps students understand key operations concepts, including the influence of variability on service performance, the role of flexibility in managing service capacity, and the value of shifting capacity in response to unpredictable changes in demand. Emergency! has been adopted by leading educational institutions, including: University of South Carolina, James Madison University, University of North Carolina and University of Victoria.

The presenter has obtained permission from the game developer “Happy Harpy Games” to present a demo at SEDSI 2020.

Presenter: Elham Torabi, PhD. James Madison University.

# Engaging Students in Evaluating Films for a Disability Film Festival: Foundational Impacts

---

Regular Session

---

*Dr . James Lawler* <sup>1</sup>

*1. Pace University*

James P. Lawler  
Pace University  
New York City, New York 10038 USA

Community engagement with disadvantaged people is a goal of a university. The author of the paper describes the engagement of students as advocate agents of change in the evaluation of films for a disability film festival program at a leading metropolitan university. The program is fostering impacts of meaningful opportunities of outreach on both people with disabilities and students.

The film festival program is designed for discovering films of actual people with disabilities aspiring to be like people without disabilities. The films are focused on actual (not Hollywood) people with disabilities functioning in life despite impairments that often preclude them from society, from which other people with disabilities in the local neighborhoods are learning more of independent living possibilities in society. From engagement with film festivals, municipal organizations and non-profit organizations focusing on this population, the author describes the design of a diversity focus group of undergraduate students that is involved in the evaluation process for the films to be included in the program each spring. The author describes the empirically favorable impacts of the process on the students, most of whom do not have disabilities, in learning of people with disabilities and in marketing the program in the local neighborhoods of the university. In engagement with the students, the author describes further in this research-in-progress paper the favorable impacts of the program on the local people with disabilities. From the film festival program, the presence of the university is pronounced in its mission of improving the potential of an aspiring but often isolated population in society.

The impacts of the film festival program are high on the local people with disabilities at the program screenings and on the students participating in the process contributing to the screenings selected by them. The author describes the best of the films, identifying high impacts of respect on the students and of self-advocacy on the people with disabilities. The initial findings of this paper will benefit faculty of urban and non-urban universities considering the creativeness of film festival programs as a feasible proposition for expanding their readiness roles in improving opportunities for disadvantaged people and involving students in service with this population.



# GROSS STATE PRODUCT AND TECHNOLOGY EFFECTS ON HEALTHCARE EXPENDITURES IN U.S. STATES, 1991-2014

---

Oral

---

***Dr. Helen You***<sup>1</sup>

*1. James Madison University*

Changes in income and technology are the two major drivers of aggregate healthcare expenditures (HCE). This study, for the first time in the literature, presents econometric model estimates of the short- and long-run effects of income (Gross State Product) and technology proxies on healthcare expenditures (HCE) using alternative panel cointegration techniques applying for the 1991-2014 available update data for US state-level health expenditures. This study makes two novel contributions to the literature: first, it uses alternative panel unit root tests and the Westerlund ECM cointegration tests; second, it uses state-level data to model the determinant of HCE with panel cointegration technique. We detect long-run cointegration relationships among HCE, GSP, and the various measures of Research and Development (R&D) activities. To handle cross-sectional dependency, we applied the updated Bai FM and CUP-FM methods based on a factor model. Findings show the estimated income elasticities of HCE fall in the 0.60 to 0.97 range depending on the R&D measure employed, and that the upper bound of the technological change effect is 0.152. Since the US state-level health care is a necessity, subsidizing and providing access to care for low-income people as the Medicaid program could see dramatic achievement on welfare improving.

# Health Disparities, The Untold Stories: An Empirical Study

---

Oral

---

*Dr . Yvette Essounga-Njan <sup>1</sup>, Dr . Sherell Price <sup>1</sup>, Ms . Maya Little <sup>1</sup>*

*1. Tuskegee University*

This discussion zooms in on the persisting gap between Blacks and Whites on a variety of health conditions. Stroke and cancer may be the major health issues that continue to leave Blacks disabled in higher numbers than they impact other ethnicities. However, these two conditions are not the only ones making salient the divide in health between Blacks and other ethnicities. This review will use data to discuss the health disparities that continue to draw a wedge between Blacks and Whites, especially looking into the causes and remedies of such disparities.

Key words: health disparities, awareness, untold stories.

# Health Disparities: What If Your Neighborhood Mattered More Than You Thought

---

Oral

---

*Dr . Yvette Essounga-Njan <sup>1</sup>, Ms . Tiombe Jones <sup>1</sup>*

*1. Tuskegee University*

## Abstract

This review discusses health disparities from the point of view of the risks populations often incur when left to live in toxic zones. Black populations, more so than individuals in other ethnicities tend to be ignorant of the risks of living in a neighborhood having been exposed to toxicity from one source or another. Further, even when aware of the risks, individuals in Black communities tend to have less options or choices regarding the places in which they may choose to reside. As a result, populations of color are the ones who are left to suffer the diseases resulting from exposure to deadly chemicals. This review shines a light on the relationship between socio-economic status (SES) and health disparities, particularly looking at the effect of one's neighborhood.

Key words: health disparities, neighborhood, SES.

---

# Healthcare Provider Recommendation Engine

---

Oral

---

***Mr . Tuhin Dasgupta<sup>1</sup>, Mr . Adrian Blue<sup>1</sup>, Dr . Burcu Adivar<sup>1</sup>, Ms . Alex Harris<sup>1</sup>, Dr . Jennifer Bushelle Edghill<sup>1</sup>, Dr . Lee Brown<sup>1</sup>, Dr . Bola Ekezue<sup>1</sup>***

*1. Fayetteville State University*

In this study, we propose a multi-criteria decision-making approach for matching patients and healthcare providers. The proposed approach features the characteristics of goal programming and location covering models to provide recommendations to patients based on rating, distance, and appointment lead times. The model can be used for developing or improving upon existing methods to improve public health outcomes, reduce health disparities, and broaden access to healthcare.

From a patient perspective, we focus on three criteria including minimizing distance, minimizing appointment lead time, and maximizing the provider rating. We compile three datasets: one with patient data, another one with healthcare provider data, and a third one with the distance of the Cartesian product of all. Data mining techniques are used to enhance the provider dataset by geocoding, adding ratings, and adding capacities. For geocoding and calculating real driving distances, we used programming languages like Visual Basic in addition to Application Program Interfaces (APIs) provided by Microsoft Bing. After implementing missing value imputation techniques, we obtained data to be used in the proposed optimization model. The multi-objective optimization model has been converted into a linear integer programming model using weights for each criterion of individual patients. For our demonstration purpose we generated the weights using an excel formula, but while implementing the model we may request patients to provide their preferred weights for each criterion. Then the resulting optimization model is solved by SAS OptModel Procedure. Model is tested with sanitized patient data and results are presented.

Working with a data set of 200+ patients and 100+ providers, we used a multi-criteria decision-making algorithm to accomplish the request. Future work would include having additional criteria, GIS integration, real-time data feed, and integration with a healthcare provider database. Future research direction is to lay out the foundation of a back-end recommendation application that public health departments could use behind a front-end application. The foundation of this model can be applied to virtually any field that requires a matching system.

---

# Improving Firefighting Traceability Processes with RFID Technology Application

---

Oral

---

*Ms. Caraline Smith<sup>1</sup>, Prof. Afrooz Moatari-Kazerouni<sup>1</sup>*

*1. University of Lethbridge*

Firefighting is a unique profession. It requires hazard engagement rather than hazard avoidance. Within such responses, firefighters may be exposed to numerous threats such as dense smoke, extreme noise and heat from the flames, confined spaces, or collapsing structures. These environmental factors make navigation for the firefighters very difficult, often resulting in confusion and disorientation. In an attempt to prevent these tragedies, it is critical to track a responder's movements within the emergency and disastrous environment. Such tracking ability will assist firefighters within the building to escape serious threats or in the event of a mayday call, assist their team in completing a rescue. This has led to the development of various technologies and search methods to improve safety standards during an emergency response, one of which is RFID.

The purpose of this research was to identify an RFID-based traceability system that could accurately track a firefighter's location during an emergency response and determine the practicality of implementation within the fire services. A case study was conducted by collecting data from several fire stations in Lethbridge, AB, Canada. Business Process Reengineering (BPR) approach was undertaken for analysing the results. Information via in-person interviews and surveys were gathered to the gain expert insight into the theory of implementing a tracking technology for their fire services, as well as understanding the equipment standards for their working conditions.

This research has investigated several scenarios for the proper placement of the RFID tag as the results of interviews and surveys. The recommended scenario is using an active RFID tag, to be sewn on the interior left side of their coats, on the back of their upper arm. This spot is preferable because the technology would not impact the firefighter's mobility, be the most protected from the environment, as well as the responder's movements, remain assigned to a specific individual as the coats are not shared and remain on a piece of equipment that is unlikely to be removed.

As a further step to this research, the fourth stage of BPR will be investigated by looking into practical sides of application of the proposed traceability system. For this means, the testing of the proposed technology at a Lethbridge Fire Station is being considered. The researchers will also explore the capability to determine vertical location of firefighters within a structure for a more accurate location navigation.

## Medical School - Business School Collaboration for Quality Improvement Training and Research

---

Oral

---

*Dr . Ashley Metcalf*<sup>1</sup>

*1. Ohio University*

Physicians and other healthcare leaders are under increasing pressure to know the fundamentals of Leadership, Patient Safety and Quality Improvement. Because of this pressure, there is a recent growth in opportunity for collaboration between business schools and medical schools to fill the gap. In this paper, I discuss the drivers and benefits of this collaboration as well as an example of collaboration using root cause analysis.

## NURSING SURVIVAL TRAITS: PREPPING TO RETAIN

---

Oral

---

***Dr . Gary Hackbarth <sup>1</sup>, Dr . Matthew Kolakowski <sup>1</sup>***

*1. Valdosta State University*

Preparation and survival traits afford nurses adaptability in a continually evolving healthcare landscape. Nurses that “prep” are employees who strive to learn, network, and express family values. To assess the potential organizational value of “prepper” nurses, we analyzed 1,171 newly licensed Registered Nurses in a 2014-2015 Cohort pulled from the Inter-university Consortium for Political and Social Research (ICPSR). Results indicated that nurses with “prepper” traits, 94.3% of respondent’s self-report good to excellent health, and 76.3% of nurses self-reported intent to stay with their current employer. Results indicate that “prepper” nurses are a critical resource to the healthcare system.

# ONLINE HEALTH COMMUNITIES: THE IMPACT OF SOCIAL SUPPORT ON THE HEALTH STATE OF PEOPLE WITH CHRONIC ILLNESS

---

Oral

---

***Dr. Zachary Davis***<sup>1</sup>

*1. Jacksonville University*

People with a chronic illness require daily medical care over the course of their lifetime and with this comes an emotional burden that is difficult to share with people not managing the same illness. Finding others with the same illness to discuss questions and concerns with used to be quite difficult but with the rise of online health communities connecting with others has become significantly easier. We examine an online health community used by people with diabetes to determine the effect of social support, in the form of informational support, emotional support, and companionship, on their overall health.



## Reducing VA Re-Admission Rates

---

Oral

---

***Ms . Stacy Passage<sup>1</sup>, Dr . Gary Hackbarth<sup>1</sup>***

*1. Valdosta State University*

Since the passing of the Affordable Care Act in 2009, there is an increased focus on reducing readmission rates. The Department of Veterans Affairs (VA) hospitals do not fall under the rules set forth by the Centers for Medicare and Medicaid (CMS). The penalties and rules imposed on Medicare hospitals do not apply to VA hospitals, making comparisons difficult. Comparing Medicare and Veterans Affairs hospitals can be challenging due to the vast difference in the number of Medicare hospitals versus VA hospitals. CMS created a program specifically designed to reduce hospital readmissions; however, the VA has not gone to the same lengths to lower readmission rates, which may contribute to why readmission rates are higher at VA hospitals for Acute Myocardial Infarction, Heart Failure, and Pneumonia. However, the rates for Chronic Obstructive Pulmonary Disease are much lower at the VA.

---

# Simulation Analysis of an Obstetrical Emergency Department Unit

---

Oral

---

**Dr . C.David Adair <sup>1</sup>, Dr . Mohammad Ahmadi <sup>2</sup>, Dr . PARTHASARATI DILEEPAN <sup>2</sup>**

1. Erlanger Health Systems, Chattanooga, TN 37410 , 2. Gary W. Rollins College of Business, The University of Tennessee  
Chattanooga, Chattanooga, TN 37403

*High acuity areas, such as emergency rooms, follow simple supply and demand curves. They have high resource value but limited availability, thus an imbalance occurs creating a high demand state. This limited availability can be maximized by simulation modeling to ascertain and identify potential obstacles to efficient resource utilization. Specialty specific emergency departments are a recent concept, which have evolved over the past two decades. Like its larger counterpart, these units can be fraught with overcrowding, which can impact care delivery. There have been several efforts to provide simulation analysis in the macrocosm of the Emergency department and other specialty units, to our knowledge none have been done to specifically examine this microcosm of an Obstetrical Emergency Department. In this paper we present such an analysis. We show that an obstetrical specialty specific emergency department has several "bottleneck" areas. These constraints project poorly to the patient and serve for frustration to care providers. By identifying and better managing these impediments, improved outcomes, better morale, and satisfaction by all can be expected. Specifically patient wait times can be minimized and quality perception improved.*

# The Effect of Information Technology Capability and Innovative Capability on Knowledge Management in Healthcare

---

Oral

---

*Dr . Christie Chen <sup>1</sup>, Mr . M. Clint Taylor <sup>1</sup>, Dr . Tommy Cates <sup>1</sup>*

*1. University of Tennessee at Martin*

Strategic management of organizations depends on the development of distinctive competencies as a means to improve performance over competing organizations and to serve customers. The sum total of the knowledge available within an organization should develop competency through IT capability and innovative capability. The integrated nature of the entire knowledge management capabilities may impact organizational performance. In fact, knowledge management capability is associated with knowledge acquisition, knowledge conversion, knowledge application, and knowledge protection (Gold et al., 2001). Typically, firms seeking to enhance their overall capabilities should first decide on necessary applications, then move to decisions about infrastructure and other required processes in support of the specific application (e.g. how knowledge will be acquired, converted and protected). Focusing on individual knowledge processes provides a more fundamental understanding of a firm's knowledge management capability while enhancing management decision-making at the resource level (Mills & Smith, 2011). The majority of previous research studies of long-term care sectors has focused on reducing deficiencies and improving quality. The objective of this current study is to investigate how information technology capability affects innovative capability and knowledge management in the long-term healthcare sector. Based on the strategic objectives of an organization, knowledge management should identify, capture, structure, and share information to help nursing facilities offer better service, thereby enabling the organization to achieve competitive advantages. Our findings indicate that IT and innovative capabilities are associated with facilities' knowledge management capability in the U.S. long-term care sector. Hence, the success of healthcare depends critically on the utilization of information technology capability and innovative capability in order to collect, analyze, and exchange knowledge within and across organizational boundaries.

# The Effects of Occupation, Income, and Gender on Psychological Distress in Canada

---

Oral

---

*Dr . Xiangdong An<sup>1</sup>, Dr . Christie Chen<sup>1</sup>, Mr . M. Clint Taylor<sup>1</sup>*

*1. University of Tennessee at Martin*

Various studies have been conducted on the relationships between psychological distress, socioeconomic status, gender, occupation, income, and lifestyle choices (e.g. fruit and vegetable consumption, physical activities and leisure-time activities). Cockerham et al. (2006) found that females carry a much heavier burden of psychological distress than males. Furthermore, their study revealed that less distressed females and males consumed a more balanced diet than more highly distressed persons. Cadieux and Marchand (2014) indicated that the level of psychological distress is significantly lower among professionals in regulated occupations than among professionals working in non-regulated occupations. However, Bultmann et al. (2001) did not find significant relationships between psychological distress and occupations. Drapeau et al. (2014) found the mean level of psychological distress to be higher in women than in men in all age groups; also, individuals in the 18-29 age group reported higher distress levels than older Canadian adults. The contexts of these various studies are generally different, and the results are not always consistent. The purpose of this study is to provide a close examination of a wider population to identify how factors such as gender, occupation, income level, and lifestyle choices affect an individual's distress level. In this paper, the Canadian Community Health Survey (CCHS) dataset is utilized to conduct our study of a sample of 14,089 people in Canada. The results indicate that among five occupation groups, individuals in the sales and services category have significantly higher distress levels than the other four groups. Additionally, the results also reveal that people with personal incomes of less than \$20,000 annually perceive significantly higher distress levels than all other groups. Furthermore, we found that lifestyle choices have a strong impact on distress levels; specifically, higher fruit consumption, as well as reduced time spent on leisure/physical activities, can reduce distress levels. Moreover, females seem to have higher distress levels than males. Finally, this present study shows that people who have longer commuting times perceive higher distress levels.

# THE IMPACT OF BACKORDERS ON THE HEALTHCARE SUPPLY CHAIN

---

Oral

---

***Ms . Helen Gillion <sup>1</sup>, Ms . Frances Newland <sup>1</sup>***

*1. Anderson University -*

Backorders are a major issue within healthcare supply chain management. Backorder processes are informal and reactive which hinders supply chain efficiency. This research study summarizes interviews with two healthcare organizations (HCOs) regarding backorder difficulties with manufacturers. In addition, a representative from a third-party logistics organization (3 PL) was interviewed for further insight. Interviewees shared recommendations based on their experience within the industry. It was discovered that internal and external communication, technological resource utilization and vendor credentialing measures have the potential to decrease issues caused by backorders. These recommendations may lead to best practices for the healthcare supply chain industry once validated. However, further research is necessary to determine the effectiveness of these approaches.

# Universal Basic Income and the Impact on Health

---

Oral

---

***Dr . Peggy Johnson***<sup>1</sup>

*1. Lander University*

Universal Basic Income and the Impact on Health

By

Dr. Peggy Johnson, Lander University

Dr. Stanley Vinson, Lander University

Abstract.

The following abstract introduces an investigation of the literature concerning Universal Basic Income and the impact on the health of a population that benefits from this approach to addressing the distribution of income. Universal Basic Income or UBI, is a version of Social Security that allows all citizens of a country to receive an amount of money each month that is not dependent on their work status or income. UBI is a term that means that the government distributes cash universally. It is different from the traditional welfare schemes by ensuring sustenance for all.

The concept of basic income has gained proponents throughout the world. It is being acknowledged by social thinkers as the best route for transforming capitalism into a more just vehicle for equally distributing gains and by the tech community concerned about the job-destroying consequence of technology. UBI pilot projects exist throughout the world. In various forms, UBI has captivated activists and intellectuals since the 1500. Thomas Moore's novel advanced the idea at the time. Many who have labored in health care over the decades have long recognized the link between poverty and poor health.

Dr. Michael Marmot in 1967 England, completed the study examining the connection between health and wealth. The Whitehall study of 18,000 men in the Civil Service was initiated. The initial Whitehall study showed that men in the lowest employment grades were much more likely to die prematurely than men in the highest grades. The second Whitehall study was set up to determine what underlies this phenomena in death and disease and to include women. Income levels in both studies predicted disease burden and mortality.

The second study examined the independent impacts of income and wealth on the burden of illness. Income is highly correlated with the level of employment, so much so that once the level of employment was accounted for, income made no additional contribution to predicting illness. Wealth is a predictor of illness and represents a balance of income and expenditure over the entire lifetime, including wealth that was inherited from previous generations. The Marmot studies identified an association between wealth and health and may represent the effect of accumulation of material and psychosocial factors on health. Additionally, wealth relates to financial security and prospects for the future, which can have an impact on rates of illness. Other studies offer similar conclusion, however, the opportunity to investigate the impact of a Universal Basic Income on health aids in further understanding the impact of increased wealth on the health of populations. This paper will present alternating views on this controversial issue.

# Using AHP to Determine the Best Location for a Free-Standing Emergency Department

---

Oral

---

*Ms . Laurel Mills <sup>1</sup>, Mr . Joseph Mazzola <sup>1</sup>, Mr . Omar Saunders <sup>1</sup>, Ms . Lila Huff<sup>1</sup>, Dr . Burcu Adivar <sup>1</sup>,  
Dr . Jennifer Bushelle Edghill <sup>1</sup>, Dr . Bola Ekezue <sup>1</sup>*

*1. Fayetteville State University*

Free-standing Emergency Departments (FSEDs) are healthcare facilities licensed by a state to provide emergency services to a community. These facilities are physically separate from a full-service hospital. While FSEDs are designated to provide the same level of access and care as a hospital-based emergency department, they are not able to provide trauma services. In this study, we utilize data mining and multi -criteria decision analysis with Analytical Hierarchy Process (AHP) to determine the best location for a Free-standing Emergency Department. The proposed methodology is demonstrated with a real business case to support the establishment of a FSED in Cumberland County, North Carolina using data from the North Carolina Healthcare Association (NCHA), Cumberland County Community Health Needs Assessments and Census data.

**Healthcare, Public Sector  
and Not for Profit  
Management - Papers**



**A CASE STUDY FOR ENABLING A NON-PROFIT ORGANIZATION TO HELP ADULT ARTISTS WITH COGNITIVE DISABILITIES THROUGH A MULTISENSORY ENVIRONMENT (MSE) OF VIRTUAL REALITY (VR)**

James Lawler

lawlerj@aol.com

Vivian Ng

vn62682n@pace.edu

Miraj Patel

mp83545n@pace.edu

Jevon Cowell

lawlerj@aol.com

Pace University

Seidenberg School of Computer Science and Information Systems

163 William Street – 2<sup>nd</sup> Floor

New York City, New York 10038, USA

**ABSTRACT**

Managers in non-profit organizations are challenged in engaging artistic people with cognitive disabilities. Multisensory environments (MSE) as facilities in non-profit organizations can be helpful however to artistic people with disabilities desiring to display their products and to express the meanings of their products in systems of virtual reality (VR). The descriptive findings of this paper highlight comfortability as a foundation for non-profit organizations to further invest in multisensory environments of virtual reality for artistic higher-functioning people with developmental and intellectual disabilities (IDD). Focus groups and surveys of the higher-functioning people at a leading non-profit organization are indicating intermediate interests in the technology of virtual reality. The paper can benefit both artistic entrepreneurial people with disabilities and non-profit organizations in considering a journey into the potential of multisensory virtual reality.

**Keywords:** Assistive Devices, Disabilities, Multisensory Environments (MSE), People with Developmental and Intellectual Disabilities (IDD), Virtual Reality, Virtual Reality Applications (Apps), Web Design

## BACKGROUND

The accessibility of computers for people with disabilities contributes to an appreciation of the abilities not the disabilities of the people with disabilities (Bowe, 1987). Multisensory environments (MSE) are “artificially [authentic] engineered environments” (Fowler, 2008) that can engage people with disabilities in imaginations with objects of interests, if not with other people, in the environments. Applications (apps) of multisensory environments coupled with artificially digital environments (VE) of immersive virtual reality (VR), with physical presences and sensory stimulations (Jerald, 2016), can enrich the interests of people with developmental and intellectual disabilities (IDD). The accessibility of these environments for people with disabilities continues to expand in the features of games (Santana, 2019). The availability of multisensory environments of virtual reality is considered a critical development for people with disabilities (Bolton, 2016).

The benefits of multisensory environments continue to be documented in the experiences of people with disabilities. Empathy of people with disabilities is boosted from multisensory environments (Hays, 2018). Multisensory environments of virtual reality are engaging people with developmental and intellectual disabilities in comfortability in diverse experiences in life, and these people are experimenting in independent living practices with the technology (Renault, 2018). Those with developmental and intellectual disabilities are exploring multisensory environments of virtual reality in interactions of skills in sociality with those with and without disabilities and are finding the interventions beneficial to them (Weidig, 2019). The benefits of multisensory environments as facilities for people with disabilities can be applied creatively to artistic people with disabilities anxious to display their products on virtual reality, with the enablement of non-profit organizations.

The evolution of multisensory environments is affording a platform for people with disabilities to display their products on immersive virtual reality. Museums are currently involved in displaying artistic products on virtual reality (Cigainero, 2018), and people with disabilities can be equally involved in displaying installations of their products with this technology. People with developmental and intellectual disabilities can be involved in demonstrating their portfolios of products as entrepreneurs (Ugelvig, 2019), expressing pride in their skills, not in mere multisensory private rooms but on public virtual reality spaces (Stanton, 2018). The pollination of the products and of the simulations of the technology is a progression of virtual reality (Schwarz, 2019) –“a platform in its own right” (Farago, 2017) – for people with disabilities. This paper examines the potential of this virtual reality for both people with disabilities and for non-profit organizations already servicing them.

## INTRODUCTION

The authors explore the feasibility of multisensory environments (MSE) of virtual reality (VR) for artistic people with disabilities at AHRC NYC, a non-profit organization partner of the Seidenberg School of Computer Science and Information Systems of Pace University. This paper involves higher-functioning people (i.e. limited support) with developmental and intellectual disabilities (IDD) at the organization who are already partnered with students on another project to migrate artistic – art and music - portfolios of products on to the Web. The migration of the presentation of the portfolios by the students to multisensory environments of virtual reality is a forthcoming project based on the feasibility of the technology discussed in this paper.

For this paper, the authors decided on the Facebook Oculus Rift S (System) with Oculus Touch (Figure 1 in Appendix), as a best-in-the-field system from literature on virtual reality (Greenwald, 2019a), and on the 3D Organon VR, Ocean Rift and Star Chart, and additionally Guided Mediation VR, Jam Studio VR and Oneiric Masterpieces – Paris (Figures 2-7), as applications (apps) for consideration for design elements (McNeil, 2014) for artistic portfolios. The experiences of the entrepreneurial developmental and intellectual people with disabilities in eventual apps scenarios, to be evaluated involving auditory, kinesthetic, tactile, vibrating and visual reality, were determined to be important in the forming or not forming of their interests in the multisensory environments for their portfolios. The Oculus Rift and the 3D Organon, Ocean Rift and Star Chart were also evaluated for interests in multisensory environments in an earlier paper of the authors (Lawler, Ng, & Patel, 2019), with alternate people with different disabilities, which was a decision element in this paper.

The authors of this paper, as explained in the forthcoming section on methodology of study, evaluated the apps from factors of the earlier paper (Lawler, Ng, & Patel, 2019). The factors included ease of use in interfacing with the apps, flexibility of use in navigating with the apps on the system, information perceptibility in perspicacity of presentations with the apps, intuitiveness in processing scenarios and sequences with the apps on the system, and limited processing requirements (i.e. headset tethered) without restrictions of the physical technology. The factors for the artistic people with disabilities integrated known principles of universal design (Figure 8) in the literature (The Center for Universal Design, 2003) relative to those with disabilities cited in the earlier paper (Lawler, Ng, & Patel, 2019) of the authors.

## FOCUS

The focus of this paper contributes an evaluation of the feasibility of multisensory environments (MSE) of virtual reality (VR) for higher-functioning people with developmental and intellectual disabilities (IDD), at the local non-profit organization. Few papers are found historically as to the impacts of multisensory environments of virtual reality (Wallis, 2019), though the hype of virtual reality is at the peak of inflated expectations in the literature (Gartner Group, 2018). Limited optimized products are found moreover in the spaces of virtual reality for those with developmental and intellectual disabilities. Nevertheless, products of virtual reality might entrepreneurially help higher-functioning people with developmental and intellectual disabilities

in increased independence in living and in inter-personal marketing, so that they might be incrementally less reliant on the limited resources of non-profit organizations. This paper is a contribution as to the potential of virtual reality technology for non-profit organizations and for people with developmental and intellectual disabilities.

### **METHODOLOGY OF STUDY**

The authors of the paper analyzed the comfortability functionality of  $n=3$  3D Organon Anatomy, Ocean Rift and Star Chart applications (apps) on the Oculus Rift system. The apps were analyzed in winter 2018 / spring 2019, from the  $n=5$  design factors of ease of use, flexibility of use, information perceptibility, intuitiveness and limited physical requirements, for each of the apps as a consideration for a multisensory environment (MSE) for artistic people with disabilities. The apps were navigated by aged 21-39  $n=24$  higher-functioning people with developmental and intellectual disabilities (IDD) from the non-profit organization already partnered with the Seidenberg School of Computer Science and Information Systems of Pace University.

In stage 1 of the paper, the second author-student confirmed the best-in-the field apps that included 3D Organon Anatomy, Ocean Rift and Star Chart for a multisensory environment for the people with disabilities, from a literature scan. In stages 2a and 2b, the third and fourth author-students of the Seidenberg School helped the  $n=24$  people with disabilities ( $n=11$  in a group 1 and  $n=13$  in a group 2, both on different days of 3-hour sessions), in initially navigating the  $n=3$  apps on the Oculus Rift system. The  $n=2$  author-students were helped by  $n=6$  organizational staff and by  $n=24$  other students already mentoring one-on-one the  $n=24$  people with disabilities on artistic designs on the Web (McNeil, 2014) that might be migrated to the multisensory environments of virtual reality (VR). However, the people with disabilities were independently navigating the apps in a Diverse Voices method (Young, Magassa, & Friedman, 2019), after first helped by the students. In stage 3 of the paper, the first author-professor initiated focus groups (both groups in different 3-hour sessions) in further investigating the  $n=3$  apps with the  $n=24$  people with disabilities and the  $n=6$  staff. The stages of the paper were supervised by the first author-professor of the study.

The evaluations of the functionality of the  $n=3$  3D Organon Anatomy, Ocean Rift and Star Chart apps on the Oculus Rift system were done by the  $n=24$  people with disabilities, confidentially interpreted by the stage 2  $n=2$  observing author-students and by the  $n=6$  observing organizational staff, with a pre-tested Likert-like script survey. The evaluations were indicated with descriptive perception ratings of (5) very high, 4 (high), (3) intermediate, (2) low and (1) very low or (0) none in comfortability satisfaction by  $n=24$  artistic people with disabilities (i.e. 24 people x 3 apps x 5 design factors = 360 occurrences) and inserted in Excel 2016 16.0 for interpretation of means (Bruce, & Bruce, 2017) by the second author-student. Finally, the evaluations were further confidentially interpreted in the focus groups (Stewart, & Shamdasani, 2015), with a semi-structured qualitative survey by the first author-professor.

The methods are equivalent to the methodology of a previous study (Lawler, Ng, & Patel, 2019) of virtual reality of a similarly small population of subjects. The methods increased the knowledge of the  $n=3$  author-students on the investigatory processes and on the non-profit organizational

problems. Their learning of multisensory environments for people with developmental and intellectual disabilities increased with the methodology of the study.

The analysis of the findings from the perceptions of the higher-functioning people with disabilities, as to the potential of virtual reality, are discussed in the next section of this study.

### **ANALYSIS OF FINDINGS OF STUDY**

The analysis of the findings in stages 2a and 2b of the survey is highlighting comfortability in the perceptions of the n=24 largely artistic people with disabilities in the study. The perceptions of the n=24 higher-functioning people with developmental and intellectual disabilities (IDD) are illustrating enriched favorability of the net of the factors of functionality (intermediate means=3.19 / 5.00), and especially favorability in the n=13 group 2 (high means=4.23) in contrast to the n=11 group 1 (low means=2.14) of the people, as observed by the staff and by the students. The factor findings of ease of use, flexibility of use, information perceptibility, intuitiveness and limited physical requirements are indicating to be empirically indistinguishable individually for the consolidated findings (intermediate means=3.19) of the groups.

The factors are however indicating individually that the people with disabilities immersed in the applications (apps) of 3D Organon VR Anatomy, Ocean Rift and Star Chart without impediment. Ease, flexibility of use and intuitiveness of the apps are indicating immediate navigation on the systems without instructions. Information literacy in perceptibility is indicating informative multimedia presentation of the art portfolios of the people with disabilities. Learning of the physical requirements of the apps systems is indicating an impediment (Metz, 2019) initially, but it is not a limitation for people persevering on the systems. The factors of functionality are indicating an immersive presence on systems of virtual reality (VR).

The findings from the perceptions of the n=24 people with disabilities are indicating Star Chart (means=3.72), 3D Organon VR Anatomy (means=3.15) and Ocean Rift (means= 3.12) favorability with the apps of the multisensory environments (MSE) of virtual reality at intermediate modest levels of satisfaction. The perceptions of the n=13 group 2 people are indicating the highest levels for 3D Organon VR Anatomy (means=4.12) and the lowest levels for Ocean Rift (means=3.73) in satisfaction, though the perceptions of the n=11 group 1 people are indicating the highest levels for Ocean Rift (means=2.50) in satisfaction with virtual reality, as observed by the session staff and by the students in stages 2a and 2b. The frequently lower perceptions of n=11 group 1 people, in contrast to the n=13 group 2 people, may be attributable to a higher number of artistic people in group 2 (n=11/13 people) than in group 1 (n=7/11 people) who already have established portfolios of their artistic products and to a limited number of people in group 1 (n=2/11 people) who have partial disorders in hearing or vision.

(Though Guided Meditation VR, Jam Studio VR and Oneiric Masterpieces – Paris were intended to be further played in this study, they were not played by the people with disabilities due to their enthusiastic elapsed playing of the other apps of the survey, which exhausted the playing time.)

The analysis of the findings in stage 3 of the focus groups is indicating favorability in results similar to the findings in stages 2a and 2b. Most of the people (17/24 people) of the focus groups are indicating interests in having their existing or future portfolios of products migrated from non-Web or Web sources to the apps of dynamic multidimensional and multisensory environments of virtual reality, a forthcoming goal of the authors. The favorability of the perceptions of the focus groups are from reflections on the sessions with the staff and the students. “I am excited for apps for my art”; “I am interested in learning more about the environments, so that I can present [my art] and myself to the public”; and “I had hope we spent more time on the systems” are a few of the reflections. In fact, the findings from the perceptions of the people with disabilities in stage 3 are indicating favorability in higher qualitative results than the quantitative results in stages 2a and 2b, as observed by the non-profit organizational staff and by the students of the university.

The findings are indicating the feasibility of an exploratory foundation for helping creative entrepreneurial people with disabilities to be independent in a larger navigational presence in multisensory environments. (Brazil, 2018). Though modest, these findings are also indicating the feasibility of a further foundation for non-profit organizations to gradually invest in multisensory environments, as facilities for involving higher-functioning motivated people with developmental and intellectual disabilities in independent opportunities with the technology. Finally, the findings of the study are indicating opportunities for both the non-profit organizational staff and the people with disabilities in productive pursuits with virtual reality.

## **IMPLICATIONS**

The findings are firstly an illustration of an occasion for non-profit organizations to incrementally invest in multisensory environments (MSE) for appropriate client people with disabilities. Higher-functioning people with disabilities, such as artistic people with developmental and intellectual disabilities (IDD), can be helped in person-centered portfolio projects through the potential of virtual reality (VR). The findings of the paper furnish an opportunity for non-profit organizations to integrate multisensory environments of virtual reality as optional services to people with disabilities.

The findings of the paper are a concurrent indication of an opportunity for people with disabilities having interests to be involved more with multisensory environments. The focus on the abilities, not the disabilities, of the artistic entrepreneurial higher-functioning people with disabilities in the paper is crucial in the customized formation of their forthcoming personal planning portfolios of products on virtual reality (Wobbrock, Gajos, Kane, & Vanderheiden, 2018). The findings highlight the interests of those with disabilities for multisensory environments as an opportunity to satisfy these people.

The findings are not however a justification for immediate investment in immersive multisensory environment platforms without caution. Multisensory environments are in a hyped nascent stage of systems (Gartner Group, 2018), indicating a challenge (Metz, 2019) for non-profit organizations in considering the usability of the virtual reality tools for their niche populations of those with

disabilities. The findings on the perceptions of positive potential of virtual reality are cautioned with a proposition for further prudent study.

Though multisensory environments are in a nascent stage of technology (Gartner Group, 2018), the findings of the paper are an indication that non-profit organizations can investigate virtual reality for those with disabilities. Managers in non-profit organizations can learn the nuances of the technology, and its usability for higher-functioning interested people with disabilities, in partnership with technology vendors and with universities, and in prototyping the technology (Hopkins, 2017), in pursuit of a strategy for virtual reality (Porter, & Heppelmann, 2017). The potential of the technology for people with disabilities is reliant on the non-profit organizational staff who were with the students of this study and who will be probably with those with disabilities with this technology of virtual reality.

Lastly, the findings of this paper are informative in the project reflections of the author-students that helped the artistic people with disabilities. In interactions with the people with developmental and intellectual disabilities, and with the non-profit organizational staff, the students in the Seidenberg School of Computer Science and Information Systems gained a repertoire of collaboration, communication and compassion, diversity and empathy, entrepreneurship, and creativity and flexibility skills. The findings are a justification for involvement of more students on projects of research with neglected non-profit organizations and populations of society, such as those in disability studies.

### **LIMITATIONS AND OPPORTUNITIES IN RESEARCH**

The findings from the authors of this paper cannot be generalized without caveats, as the implications are from a relatively small population partnered at one school of computer science and information systems. The people with disabilities in this paper do not include other people with physical (e.g., muscular dystrophy), sensory (e.g., cortical visual impairment) or severe disabilities, a diversity of people that might benefit from a multisensory environment system (Bailey, 2019). Furthermore, the project is an indirect simulation of a multisensory environment (MSE) for the portfolios of the limited population with disabilities in the study.

Nevertheless, the findings from this study furnish a helpful incentive into apps offerings (Lathan, & Maynard, 2018) and other offerings (Greenwald, 2019b) of opportunities, such as Oculus Quest (Headset Standalone) / Oculus Touch (Wire Free) vs. HTC Vive and PlayStation VR, and of other technology vendors, which might be pursued by the non-profit organization for client people with developmental and intellectual disabilities (IDD). To expand learning into these opportunities, the Seidenberg School of Computer Science and Information Systems of Pace University will be hosting a laboratory for new partnership research sharing on virtual reality (VR).

## CONCLUSION

The paper is contributing findings as to the feasibility of multisensory environments (MSE) for artistic entrepreneurial people with disabilities, as the findings from the perceptions of the people are of modest satisfaction from the systems of virtual reality (VR). Though in a nascent stage of technology, multisensory environments can be facilities for higher-functioning people to display their portfolios of products and to express themselves as high potential persons. Importantly, multisensory environments can be a foundation for non-profit organizations for fruitfully helping higher-functioning people with developmental and intellectual disabilities (IDD) to be independently productive and to be proud of their skills and of themselves through inherent sensory therapy of virtual reality. Moreover, non-profit organizations can improve their knowledge of the potential of this technology through planned research sharing with universities if not vendors investing in virtual reality. In conclusion, the findings of this study can be beneficial to both non-profit organizations and client people with developmental and intellectual disabilities in evaluating the power of virtual reality.

## REFERENCES

- Bailey, J.M. (2019). A Controller That Gives Disabled Gamers Real Control. *The New York Times*, February 26, B3.
- Bolton, D. (2016). Why Virtual Reality Could Be a Game Changer for the Disabled. *ARC Applause*, March 21, 1-7.
- Bowe, F. (1987). Making Computers Accessible to Disabled People. *MIT Technology Review*, 90, January, 52-59,72.
- Brazil, B. (2018). Virtual World Provides Haven for Those with Special Needs. *Disability Scoop*, October 16, 1-4.
- Bruce, P., & Bruce, A. (2017). *Practical Statistics for Data Scientists: 50 Essential Concepts*. O'Reilly Media, Inc., Sebastopol, California, 2-28,44-49.
- Cigainero, J. (2018). European Museums Venture into Virtual Reality. *The New York Times*, March 15, F36.
- Farago, J. (2017). Virtual Reality Has Arrived in the Art World. Now What? *The New York Times*, February 3, 1-6.
- Fowler, S. (2008). *Multisensory Rooms and Environments: Controlled Sensory Experiences for People with Profound and Multiple Disabilities*. Jessica Kingsley Publishers, Philadelphia, Pennsylvania, 14.
- Greenwald, W. (2019a). Oculus Rift S Review and Rating. *PC Magazine*, April 30, 1-16.
- Greenwald, W. (2019b). Oculus Quest vs. Oculus Rift S: Which Virtual Reality Headset Should You Buy? *PC Magazine*, April 30, 2-10.



- Hays, B. (2018). Virtual Reality Can Boost Empathy. *Science News*, October 17, 1-10.
- Hopkins, M. (2017). Pioneering Visual Technologies in Journalism. *The New York Times*, October 19, B4.
- Jerald, J. (2016). *The VR Book: Human-Centered Design for Virtual Reality*. Morgan and Claypool Publishers, Waterloo, Illinois, 9.
- Lathan, C.E., & Maynard, A. (2018). Augmented Reality Everywhere: The World Will Be Overlaid with Data. *Scientific American*, December, 30.
- Lawler, J., Ng, V., & Patel, M. (2019). Evaluating the Feasibility of Virtual Reality for High School Students with Autism Spectrum Disabilities (ASD). *Proceedings of the Southeast Decision Sciences Institute (SEDSI)*, Savannah, Georgia, February 21, 1-13.
- McNeil, P. (2014). *The Web Designer's Idea Book: Inspiration from the Best Design Trends, Themes and Styles, Volume 4*. HOW Books, Cincinnati, Ohio, 048-126,164-219.
- Metz, R. (2019). The New Oculus Headset Shows How Far Virtual Reality Has Come. It Is Still Not Enough. *CNN Business*, April 30, 1-4.
- Porter, M.E., & Heppelmann, J.E. (2017). Why Every Organization Needs an Augmented Reality Strategy. *Harvard Business Review*, November – December, 46-57.
- Renault, H. (2018). Virtual Reality Is Helping People with Disabilities Conquer Overwhelming Real-Life Situations. *ABC.Net News*, July 6, 1-5.
- Santana, M. (2019). Accessibility Options Expanding for Video Games. *Disability Scoop*, January 22, 1-3.
- Schwarz, G. (2019). Where Next for Virtual Reality Art? *Apollo: The International Art Magazine*, January 4, 1-18.
- Stanton, S. (2018). Creating Art in Virtual Reality – And Then Entering It. *Wired*, April, 1-4.
- Stewart, D.W., & Shamdasani, P.N. (2015). *Focus Groups: Theory and Practice*, Third Edition. Sage Publications, Inc., Thousand Oaks, California, 97-112,115-139.
- Ugelvig, J. (2019). 8 Artists Pushing the Limits of Digital Effects and Virtual Reality. *Artsy*, April 24, 1-3.
- Wallis, C. (2019). The Promise of Virtual Reality. *Scientific American*, February, 18.
- Weidig, D. (2019). Researchers Explore Virtual Reality to Build Crucial Social and Safety Skills. *Autism Spectrum News*, Spring, 23,33.
- Wobbrock, J.O., Gajos, K.Z., Kane, S.K., & Vanderheiden, G.C. (2018). Ability-Based Design. *Communications of the ACM*, 61(6), June, 62-71.

Young, M., Magassa, L., & Friedman, B. (2019). Toward Inclusive Technical Policy Design: A Method for Underrepresented Voices to Strengthen Technology Policy Documents. *Ethics and Information Technology*, 21, 90-92,94-96.

\_\_\_\_ (2003). The Principles for Universal Design. *The Center for Universal Design*, July 31.

\_\_\_\_ (2018). Gartner Group Hype Cycle 2018. *Gartner Group*, April 19, 1-6.

### ACKNOWLEDGEMENTS

The first-author professor is grateful to the Helene and Grant Wilson Center for Social Entrepreneurship of Pace University for the funding of \$5,000 for this study.

### APPENDIX



Figure 1: Oculus Rift S (System)



Figure 2: 3D Organon VR App



Figure 3: Ocean Rift App



Figure 4: Star Chart App

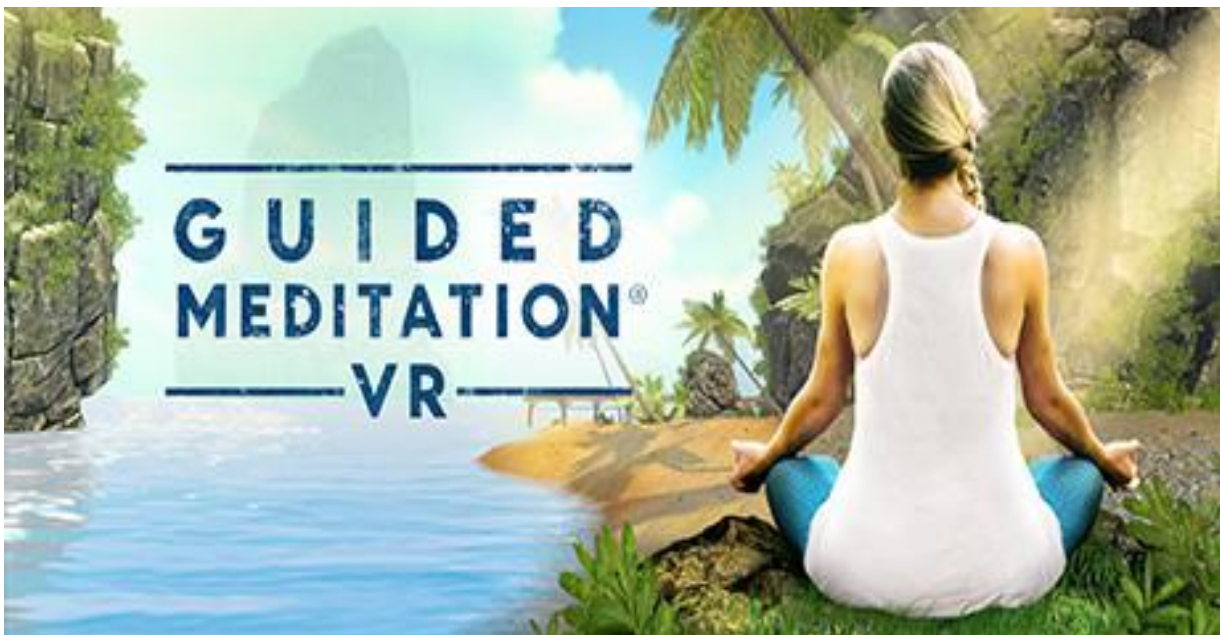

Figure 5: Guided Meditation VR App



Figure 6: Jam Studio VR App



Figure 7: Oneiric Masterpieces Paris App

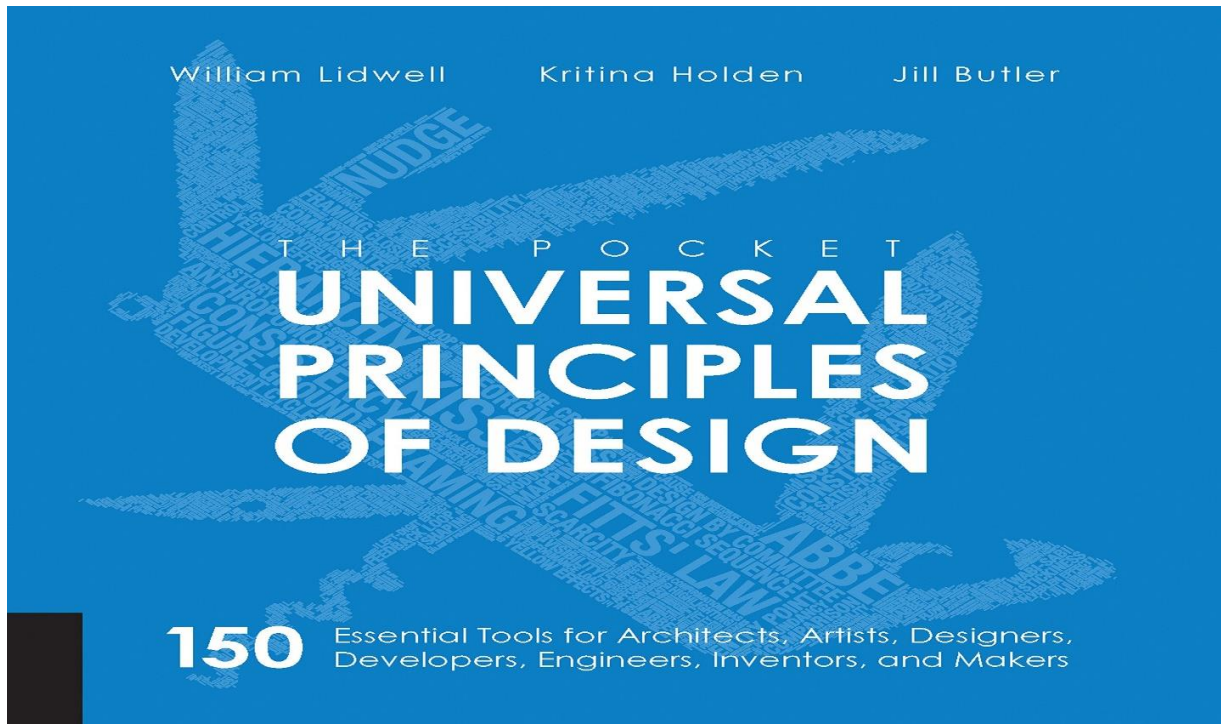

## **COMMON COMPETENCIES FOR HEALTHCARE MANAGERS: A COMMUNITY PERSPECTIVE**

Matthew Kolakowski, Langdale College of Business Administration, Valdosta State University, 1500 North Patterson Street, Valdosta, GA 31698, 229-253-2912, mjkolakowski@valdosta.edu

Sherif A. Ebrahim, A. B. Freeman School of Business, Tulane University, Goldring/Woldenberg, Business Complex, 7 McAlister Drive, New Orleans, LA 70118, 504-865-5622, sebrahim@tulane.edu

Janice Pittman, School of Business, Union University, 1050 Union University Drive, Jackson, TN 38305, 731-668-1818, jpittman@uu.edu

### **ABSTRACT**

Today's healthcare environment requires an examination of what it means to be a fully competent leader. As a result, an upsurge in interest in healthcare management competencies has resulted. The present study utilizes a diverse group of informants as participants: health management practitioners, multi-disciplinary faculty groups, and health service consumers. Using the competency directory published by the Healthcare Leadership Alliance (HLA), this study examined which traits are essential in the provision of quality healthcare services. Additionally, demographic questions were used from the American Health Values Survey to prevent ontological oscillation. Using survey data collected from 139 respondents, this study reveals that leadership was the only statistically significant competency. Implications for the practice of healthcare management are discussed.

**Keywords:** Healthcare Management, Health Professionals, Competencies, Leadership

### **INTRODUCTION**

The complexity of healthcare institutions across the United States has continually increased since the passing of the Affordable Care Act (ACA) in 2010. Before 2010, Drucker (2012) noted that "large healthcare institutions may be the most complex in human history and that even small healthcare organizations are barely manageable" [8]. Several years have passed since both observations; however, the demands this degree of complexity has placed on leaders and healthcare management educators have not diminished. Additionally, healthcare executives are required to navigate a systemically complex network of a socially and politically influenced landscape, decreasing reimbursements, increased indigent care costs, continual shortages of qualified health professionals, and ineffective performance and safety indicator implementation [23]. In an environment where demand for health services is continually escalating, it is only logical to gauge the competence of current and future healthcare leaders.

In the publication *futurescan*, Don Seymour reflected on the state of healthcare from 1998 to 2008 by stating, “taking care of more people who have growing expectations and more complex medical needs while providing increasingly sophisticated care with relatively fewer resources is becoming the new norm” [10]. If complexity, resource constraints, and increased patient volume are the new normal, have healthcare leaders, and educational programs kept pace? Several studies ([20], [17], [18], [3], [25], [5]) have assessed and developed healthcare leadership competencies; however, implementation has been sporadic and inconsistent across the continuum of care. Since several studies have addressed constructing competency models, the question now becomes: Have we included all pertinent stakeholder input in the development of health service leader competencies?

### **PURPOSE OF THIS STUDY**

The purpose of this study is to assess healthcare leader competencies from the perspective of academics, health leaders, and health service customers and consumers (Payors and Patients). The employed framework measures the perception of multiple stakeholders on which skill sets are critical for successful healthcare leaders to possess in the delivery of high-quality patient care. Three key informant groups, health management practitioners, multi-disciplinary faculty groups, and health service consumers, responded to these critical issue domains in terms of the competencies required of those individuals entering and practicing within the field.

Competencies measure healthcare administrator’s ability to:

1. Impact a significant part of one’s job performance.
2. Optimize the provision of healthcare services.
3. Be measured against well-accepted standards and improved through continual training and development [19].

### **THE COMPETENCY MOVEMENT**

The evidence-based approach to healthcare management education and leadership did not happen overnight [18]. While evidence-based medicine has been in practice for decades, this concept realized significant implementation delays in both healthcare management leadership and education circles. From the design of curricula in academia to organizational leadership development, healthcare remains one of the most complicated environments to achieve consistent, evidence-based leadership practices. Healthcare administration has made progress towards evidence-based leadership practice even though operational complexity continues to increase. This progress can be best measured by the age-standardized mortality rate per 100,000 population (95% UI) resulting from the adverse effects of medical treatment (AEMT). From 1990 to 2016, the age-standardized mortality rate resulting from AEMT decreased from 1.46 to 1.15 per 100,000 of the United States population (Sunshine et al., 2019). This 21.4% decrease in deaths related to AEMT demonstrates that the competency movement in healthcare administration is promising but has not yet reached its full potential in the profession.

HLA is a consortium of professional associations that have been at the forefront of developing evidence-based healthcare administration competencies. These associations include:

- American College of Healthcare Executives (ACHE)
- American College of Physician Executives (ACPE)



- American Organization of Nurse Executives (AONE)
- Healthcare Financial Management Association (HFMA)
- Healthcare Information and Management Systems Society (HIMSS)
- Medical Group Management Association (MGMA) and its educational affiliate, the American College of Medical Practice Executives (ACMPE).

These associations represent over 100,000 healthcare administration professionals and, through a mutual interest in creating healthcare leadership competencies, convened a competency task force. This task force subsequently formed a directory of 300 competency statements that shaped how four associations (ACHE, HFMA, HIMSS, and ACMPE) determined KSAs for certification exams. Reputable psychometric firms ensured the reliability and validity of their (ACHE, HFMA, HIMSS, and ACMPE) processes. In general, the certification process of HLA organizations was designed for early careerists in healthcare administration to demonstrate their competence. Through the HLA organization certification process, healthcare administrators should be able to demonstrate proficiency in these five competency domains:

1. Communication and Relationship Management: The ability to communicate clearly and concisely with internal and external customers and to establish and maintain relationships.
2. Leadership: The ability to inspire individual and organizational excellence, to create and attain a shared vision, and to successfully manage change.
3. Professionalism: The ability to align personal and corporate conduct with ethical and professional standards that include a responsibility to the patient and community.
4. Knowledge of the Healthcare Environment: The demonstrated understanding of the healthcare system and the environment in which healthcare managers and providers function.
5. Business Skills and Knowledge: The ability to apply business principles, including systems thinking, to the healthcare environment; basic business principles include (a) financial management, (b) human resource management, (c) organizational dynamics and governance, (d) strategic planning and marketing, (e) information management, (f) risk management, and (g) quality improvement.

These competency domains serve as clusters that transcend unique organizational settings and are applicable across the operational environment [20]. The ability for these competency domains to transcend individual, organizational settings has likely been a contributing factor in the 21.4% reduction in AEMT since 1990. The potential this body of knowledge has demonstrated to break down barriers between health management professionals and provide a stronger basis for collaboration is promising [23]. Since leadership is central to healthcare administrators' performance, the leadership domain anchors the HLA model [23]. All other domains draw from the leadership area, but the other competencies also feed and inform leadership. In Figure 1, the two-way arrows outside the circles indicate that the other four domains draw from each other and share overlapping KSAs.

Figure 1- Healthcare Leadership Alliance Competency Model

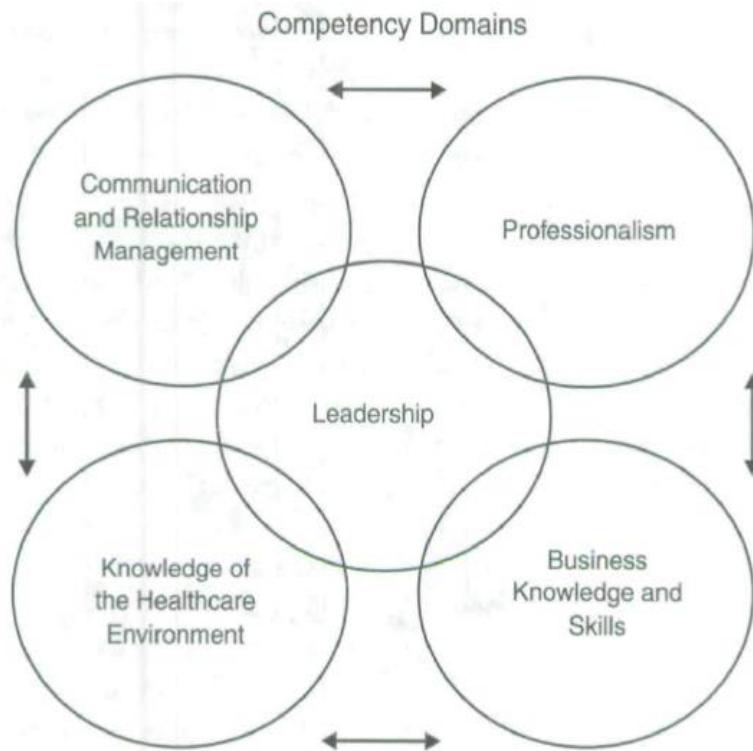

Source: 2005©, All Rights Reserved by Members of the HLA Competency Task Force: American College of Healthcare Executives, American College of Physician Executives, American Organization of Nurse Executives, Healthcare Financial Management Association, Healthcare Information and Management Systems Society, and the certification body of the Medical Group Management Association—American College of Medical Practice Executives.

### SHARED FRAMEWORK FOR COMPETENCY DEVELOPMENT

One of the drawbacks of competency development is dependent on a wide array of diverse interests [22]. Key competency domains are developed first; then examples derive how one might demonstrate mastery [22]. When domains are removed from specific contexts and actual behaviors, they have the potential to lose meaning in relation to important outcomes. With these numerous challenges and no potential path for a “one size fits all” solution, it's essential to gauge a baseline of core competencies. While healthcare administration programs and several professional organizations have been involved in competency development, the consumer (patient) has not. Subsequently, it is essential to incorporate diverse input on competency development.

ACA has catalyzed a move to integrated systems such as Accountable Care Organizations (ACOs), Physician-Hospital Organizations (PHOs), and Independent Physician Associations (IPAs). This movement, to a vertically integrated delivery system, has challenged healthcare executives to possess diverse skill sets, including health system management, physician leadership, risk, and quality management. The sheer complexity of healthcare competencies suggests that “there is not another industry where the understanding of core competence is as

crucial as it is today” [20]. This study utilizes the American College of Healthcare Executives (ACHE) Twenty-two question self-report short survey to measure the five competency domains listed in figure 1. Four items from the American Health Values Survey integrates necessary demographic information. Based on this understanding, we propose the following two hypotheses:

H1: *Respondents, regardless of education level, will opt for healthcare administrators that have diverse and well-rounded competency sets.*

H2: *Level of education will positively influence to what degree respondents desire having access to high-quality healthcare administrators and services.*

## METHODS

### *Participants and Procedures*

This study attempts to gain a community perspective on what healthcare administration competency domains are perceived to be linked to high-quality healthcare services. We have drawn from literature ([20], [17], [3], [25], [5].) to develop an abbreviated yet impactful measurement of healthcare administrator competency domains. The instrument was constructed in Qualtrics to ensure quality control, data security, and the uniformity of distribution to all potential respondents.

Using Qualtrics, we reached out to 1,000 potential respondents that include healthcare administrators, faculty, and staff members from Valdosta State University and received 139 usable responses for a response rate of 13.9%. The Qualtrics survey included four demographic questions to include the respondent’s occupation, level of education, gender, and importance of access to high-quality health care in the community in which they currently reside. Twenty-two questions from the 2018 American College of Healthcare Executives (ACHE) competencies assessment tool measured the respondent’s penchant for each of the five competency domains. The five competency domains measured include Communication and Relationship Management, Professionalism, Leadership, Knowledge of the Healthcare Environment, and Business Knowledge and Skills.

### *Measures*

*Communication and Relationship Management.* Communication and relationship management skills were measured with 3-items on a five-point Likert scale (1= Not Important, 5= Very Important) to indicate their perception of this healthcare administration competency domain.

*Leadership.* Leadership was measured with 3-items on a five-point Likert scale (1= Not Important, 5= Very Important) to indicate their perception of this healthcare administration competency domain. Leadership in this study was defined as the ability to inspire individual and organizational excellence, create a shared vision, and successfully manage change.

*Professionalism.* Professionalism was measured with 3-items on a five-point Likert scale (1= Not Important, 5= Very Important) to indicate their perception of this healthcare administration competency domain. Professionalism in this study was defined as the alignment of personal and professional organizational conduct with ethical and professional standards that include a responsibility to the patient and community.

*Knowledge of the Healthcare Environment.* Knowledge of the healthcare environment was measured with 7-items on a five-point Likert scale (1= Not Important, 5= Very Important) to indicate their perception of this healthcare administration competency domain. Knowledge of the healthcare environment in this study was defined as the understanding of the healthcare system and environment in which healthcare managers and providers function as well as how patients receive care.

*Business Skills and Knowledge.* Business skills and knowledge was measured with 6-items on a five-point Likert scale (1= Not Important, 5= Very Important) to indicate their perception of this healthcare administration competency domain. Business skills and knowledge in this study was defined as the ability to apply business principles, including systems thinking, to the healthcare environment.

#### *Dependent Variable*

*Importance of Access to High-Quality Healthcare.* The dependent variable selected was access to high-quality healthcare. This allowed for analysis of not only healthcare administration competencies but how the respondent's penchant for access to high-quality healthcare services impacts each domain.

#### *Measure Validation*

Since no previous scholarly studies were located after searching four major databases (ProQuest, JSTOR, Scopus, and EBSCO, it was necessary to establish item reliability, composite reliability (CR), and convergent and discriminant validity for each construct. Therefore, in this study, I examined each construct based on standardized items. After establishing acceptable reliability for each construct, we conducted a confirmatory factor analysis (CFA) to test potential theoretical linkage. The CFA will be used to confirm convergent and discriminant validity as well as ensuring the homogeneity of domain items.

The communication and relationship management construct were created with three questions from the 2018 ACHE competency assessment tool. For the communications and relationship management construct, Cronbach's Alpha based upon standardized items was .72, which exceeded the .70 cut off proposed [7]. The leadership construct was created with three questions from the ACHE instrument. For the leadership construct, Cronbach's Alpha based upon the standardized items was .74, which exceeded the .70 cut off proposed by Cronbach. The professionalism construct was created with two questions from the ACHE instrument, which measured the ability to align personal and organizational conduct. For the professionalism construct, Cronbach's Alpha based on the standardized items was .72, which exceeded the .70 cut off proposed by Cronbach. The business skills and knowledge construct were created with four questions from the ACHE instrument, which measured the ability to apply business principles, including systems thinking, to the healthcare environment. For the business skills and knowledge construct, the Cronbach's Alpha based on standardized items was .85, which exceeded the .70 cut off proposed by Cronbach. The knowledge of the healthcare environment construct was created with six questions from the ACHE instrument, which measured the understanding of the healthcare system and environment in which healthcare managers and providers function. For the knowledge of the healthcare environment construct, the Cronbach's Alpha based on standardized items was .64, which did not meet Cronbach's proposed .70 cut off and was subsequently dropped from further analysis.

Before factor analysis, the factorability of the data was assessed. Applying Hair et al. (2006) sampling adequacy cut-off criteria of .50, five additional items were dropped, including the professionalism construct [11]. The model retained includes 11 items across three competency domains- communication and relationship management, leadership, and business skills and knowledge. Table 1 provides a summary of the composite reliability and convergent validity of each construct [12].

Table 1

*Summary of Factor Composite Reliability (CR) and Average Variance Extracted (AVE) (N = 139)*

Construct	CR	AVE
Leadership	0.74	0.68
Communication and Relationship Management	0.72	0.53
Business Skills and Knowledge	0.84	0.68

Note: CR suggested minimum is .70 and AVE suggested minimum is .50

Composite reliabilities of each construct showed reasonable internal consistency as each measure was over the .70 cut-off criteria [16]. To check discriminant validity, this study used the guidelines proposed [16]. Table 2 summarizes the results, which indicate that “the measured variables have more in common with the construct they are associated with than they do with the other constructs” [16].

Table 2

*Factor Inter-Item Correlations (N = 139)*

Construct	Leadership	Communication and Relationship Management	Business Skills and Knowledge
Leadership	1.000	.491	.624
Communication and Relationship Management	.491	1.000	.383
Business Skills and Knowledge	.624	.383	1.000

Note: Factor inter-item correlations calculated utilizing JASP.

The resulting convergent and discriminant validity reasonably confirm that the indicators and constructs warrant investigating the overall model fit. Following the guidelines set forth by Kenny (2015), the fit indices assessed in this study include the following: Chi-Square of Model Fit, Root Mean Square Error of Approximation (RMSEA), Comparative Fit Index (CFI), Tucker Lewis Index (TLI), and Standardized Root Mean Square Residual (SRMR) [15]. Each of these statistical fit indices is widely utilized and provide a reasonable set of criteria by which to assess the fit of a model. The chi-square of the proposed model was statistically significant ( $P = 0.01$ ); however, this statistic requires further examination. The present model had 38 degrees of freedom and value of 59.115 for a ratio of 1.55 [12]. The ratio of the chi-square statistic to the

degrees of freedom provides the first goodness of fit metric in which ratios less than or equal to 2 indicated a good fit [26].

The next measure examined was RMSEA, and was assessed using the following criteria: 0.01, 0.05, and 0.08 indicated excellent, good, and mediocre fit, respectively [12]. The RMSEA of the proposed study was 0.063, which indicates a reasonable fit [12]. The next two fit indices examined were the CFI and the TLI. The acceptable fit, as defined by Hu and Bentler (1999), is  $>.90$  for both indices. In this study, the CFI was 0.96, and the TLI was 0.94, which indicates a good fit [12]. The final index examined was the SRMR in which the acceptable fit  $P < 0.08$ . In this study, the SRMR was 0.06, which indicates a good fit because it is less than 0.08 (Hu & Bentler, 1999). To summarize, the examination of each fit index in Table 3 shows that the overall model demonstrates a reasonable fit in comparison with the acceptable levels.

Table 3

*Summary of Confirmatory Factor Analysis Fit Indices (N = 139)*

Fit Index	Actual Results	Acceptable Fit
Chi-Square	0.01	$<0.05$
RMSEA	0.06	$<0.08$
SRMR	0.06	$<0.08$
TLI	0.94	$>0.90$
CFI	0.96	$>0.90$

Note: *Fit Indices were calculated utilizing JASP.*

The item reliability, CR, and convergent and discriminant validity of the resulting model provides the opportunity to explore not only the effects of the remaining competency domains but also the impact of the level of education.

## RESULTS

Before proceeding with regression analysis, the indicators of communication and relationship management, leadership, and business skills and knowledge were combined and mean centered according to the guidelines set forth by Aguinis (2004) [1]. This process ensured that the mean of each construct was set to 1.000, and it decreased the correlation between the multiplicative terms [1]. For Hypothesis 1, communication and relationship management, leadership, and business skills and knowledge will be isolated as the independent variables and importance of access to high-quality healthcare services as the dependent variable. For Hypothesis 2, communication and relationship management, leadership, and business skills and knowledge will be isolated as the independent variable and importance of access to high-quality healthcare services as the dependent variable. The level of education will be a selection variable and separate various groups of respondents by education to discern potential variation. Table 4 below summarizes each of the three models tested- All respondents, respondents with at least a bachelor's degree (N=73), and respondents that graduate high school or technical college (N=66).

From the three regression models, no conclusive evidence was found in support of hypothesis 1 that generalizable healthcare administration competencies are preferred over specialized leaders. For hypothesis 2, support was found that the level of education impacts how respondents

perceive the importance of healthcare administrator competency domains. It appears that as the level of education rises, so does the importance of having competent healthcare administrators providing health services.

Table 4  
Summary of Regression Analysis for Healthcare Competency Domains ( $N = 139$ )

Variable	Model 1 (All Respondents)			Model 2 (Respondents with Bachelor's Degree or Higher, $N=73$ )			Model 3 (Respondents with Trade/Technical School or High School Graduate, $N=66$ )		
	<i>B</i>	<i>SE B</i>	<i>P-Value</i>	<i>B</i>	<i>SE B</i>	<i>P-Value</i>	<i>B</i>	<i>SE B</i>	<i>P-Value</i>
<i>Construct</i>									
Communication and Relationship Management	0.077	0.062	.21	0.195	0.055	.001**	-0.110	0.131	.40
Leadership	0.092	0.046	.04*	0.103	0.037	.007**	0.108	0.110	.32
Business Skills and Knowledge	-0.257	0.047	.55	-0.076	0.040	.06	0.053	0.100	.59
$R^2$		0.045			0.241			-0.018	
$F$		3.158			8.608			0.621	

Note: \* $p < .05$ . \*\* $p < .01$ .

## DISCUSSION AND IMPLICATIONS

Surprisingly, the only statistically significant competency domain across multiple models in this sample was leadership. The top-ranked skill in several previous studies ([20], [17], [3], [25], [5], [19]) was leadership to include leading healthcare providers and facilitate the strategic direction. As the industry continues to grow in scale and complexity, leadership will be the essential navigation tool in healthcare administrator competency. This change has already impacted how physicians practice medicine, and ancillary service providers are incentivized. Furthermore, hospitals are changing how they view patient care and are transitioning from the focus on volume of patients to quality of care as the Merit-Based Incentive Payment System (MIPS), Medicare Access and CHIP Reauthorization Act of 2015 (MACRA), and Accountable Care Organizations (ACOs) are firmly entrenched in the reimbursement landscape.

Healthcare administrators will now have to lead, communicate, and manage the vision of quality over quantity of care provided as major insurers have tied financial reward systems to this criterion. Collaboration with Chief Medical Officers (CMOs) will have to become more dynamic as physician incentives have changed to keeping patients out of the hospital, reducing readmissions, and the number of days the patients are in the hospital. The time-honored adage in healthcare operations of *no margin, no mission* is more critical than ever. With the transformation of payment systems, hospitals across the United States will be compensated based upon population management, quality, and subsequently will require a new generation of healthcare administrators to be more astute with resource allocation across the organization. Furthermore, this newfound risk-sharing will require investments in technology, workflow, and care management systems. The domain of leadership does not denote that healthcare administrators must become masters of several dozen skill sets; rather, it indicates that transformational leadership will become a priority in successful health systems. It is also evident that healthcare administrator competency domains will continue to evolve and shift as the era of healthcare reform and transformation is upon us.

## LIMITATIONS

As with all empirical work, this study has its limitations. This study uses self-reported, cross-sectional data from a diverse group of respondents; therefore, causality cannot be inferred. Additionally, the 13.9% response rate is on the minimum end of averages on individual and organization email surveys [4]. In future iterations, more comprehensive follow up approaches (or method) will be required to engage the potential respondent pool. As response rates had dropped from 64.4% in 1975 to 48.3% in 2005, it is possible that extracting maximum participation requires a diverse engagement approach (or method). It is feasible that 22 items measuring five healthcare administration competency domains are not robust enough to adequately assess something of this complexity. Another limitation is related to the sample. The data for this study was collected from a lone source (Qualtrics) using a single collection method. It may be advisable to isolate specific populations and incorporate more items that measure communication and relationship management, leadership, and business skills to prevent potential recall bias.

Determining average years of healthcare experience could assist in examining whether the surveyed healthcare administrators and stakeholders are considered novices or experts within the field. Future studies could include questions about specific areas of medicine to better gauge which sectors of the health system favor certain competency domains over another. Finally, additional work could focus on measurement constructs. While several professional organizations have undertaken time-intensive attempts to measure healthcare administration competency domains, limited examples exist where empirical validation techniques were utilized. It is possible that respondents experienced confusion due to question complexity and could benefit from further refinement and empirical testing. Furthermore, the similarity of the questions between the knowledge of the healthcare environment and business skills knowledge led to one construct being dropped before testing the hypothesized model.

## CONCLUSION

Healthcare competency domain acquisition, development, and refinement drive the transformation of the health services operating environment. Healthcare administrators must consistently mitigate a vast array of risks while managing an environment that continually increases in complexity. One of the goals for this study was to demonstrate that developing healthcare administrator competencies require a diverse group of stakeholder input. From the analysis presented, the development and understanding of healthcare administrator competency domains cannot be static or a one-time event. As the healthcare environment continues to transform at a rapid rate, leadership in health systems, and refining the measurement of which domains are delivering impact will continue to be dynamic and remain a priority.



## REFERENCES

- [1] Aguinis, H. (1995). Statistical power problems with moderated multiple regression in management research. *Journal of Management*, 21(6), 1141-1158.
- [2] Aguinis, H. (2004). *Regression analysis for categorical moderators*. Guilford Press.
- [3] Bradley, E. H. (2003). "Use of Evidence in Implementing Competency-Based Healthcare Management Training." *Journal of Health Administration Education* 20 (4): 287-304.
- [4] Baruch, Y., & Holtom, B. C. (2008). Survey response rate levels and trends in organizational research. *Human Relations*, 61(8), 1139-1160.
- [5] Calhoun, J. C., P. L. Davidson, M. E. Slnoris, E. T. Vincent, and J. R. Griffith (2002). "Toward an Understanding of Competency Identification and Assessment in Health Care Management." *Quality Management in Health Care*, (1): 14-38.
- [6] Calhoun, I. G., E. T. Vincent, G. R. Baker, P. W. Butler, M. E. Sinoris, and S. L. Chen (2004). "Competency Identification and Modeling in Healthcare Leadership." *Journal of Health Administration Education* 21 (4): 419-440.
- [7] Cronbach, L. J. (1951). Coefficient alpha and the internal structure of tests. *Psychometrika*, 16(3), 297-334.
- [8] Drucker, P. (2012). *Managing in the next society*. Routledge.
- [9] Flavell, J. H. (1979). Metacognition and cognitive monitoring: A new area of cognitive-developmental inquiry. *American psychologist*, 34(10), 906.
- [10] Futurescan (2008) *Healthcare Trends and implications 2008-2013*. Chicago: Health Administration Press and the Society of Healthcare Strategy and Market Development.
- [11] Hair, J. F., Black, W. C., Babin, B. J., Anderson, R. E., & Tatham, R. L. (1998). *Multivariate data analysis* 5(3), 207-219.
- [12] Hu, L. T., & Bentler, P. M. (1999). Cutoff criteria for fit indexes in covariance structure analysis: Conventional criteria versus new alternatives. *Structural equation modeling: a multidisciplinary journal*, 6(1), 1-55.
- [13]. Jaccard, J., & Turrisi, R. (2003). *Interaction effects in multiple regression* (No. 72).
- [14] Kaplowitz, M. D., Lupi, F., Couper, M. P., & Thorp, L. (2012). The effect of invitation design on web survey response rates. *Social Science Computer Review*, 30(3), 339-349.
- [15] Kenny, D. A. (2015). *Measuring model fit*.
- [16] Kline, P. (2013). *Handbook of psychological testing*. Routledge.
- [17] Kovner, A. R. (2001). "The Future of Health Care Management Education: An Evidence-Based Approach." *Journal of Health Administration Education* (Special Issue): 107-116.
- [18] Kovner, A. R., and T C. Rundall, (2006). "Evidence-Based Management Reconsidered." *Frontiers of Health Services Management* 22 (3): 3-21.
- [19] Love, D. B., & Ayadi, M. F. (2016). Redefining the core competencies of future healthcare executives under healthcare reform. *Administrative Issues Journal: Connecting Education, Practice, and Research*, 5(2).
- [20] Ross, A., F. I. Wenzel, and J. W. Mitlyng. (2002). *Leadership for the Future: Core Competencies in Healthcare*. Chicago: HAP.
- [21] Shewchuk, R. M., S., O'Connor, and D. I. Fine (2005). "Building an Understanding of the Competencies Needed for Health Administration Practice." *Journal of Healthcare Management* 50 (1) : 32-47.
- [22] Shewchuk, R. M., S., O'Connor, and D. I. Fine (2006). "Bridging the Gap: Academic and Practitioner Perspectives to Identity Early Career Competencies Needed in

- Healthcare Management." *Journal of Health Administration Education* 23 (4):366-392.
- [23] Stefl, M. E. (2008). Common competencies for all healthcare managers: The Healthcare Leadership Alliance model. *Journal of healthcare management*, 53(6).
- [24] Sunshine, J. E., Meo, N., Kassebaum, N. J., Collison, M. L., Mokdad, A. H., & Naghavi, M. (2019). Association of Adverse Effects of Medical Treatment with Mortality in the United States: A Secondary Analysis of the Global Burden of Diseases, Injuries, and Risk Factors Study. *JAMA network open*, 2(1).
- [25] Westera, W (2001). "Competencies in Education: A Confusion of Tongues." *Journal of Curriculum Studies* 33 (1): 75-88.
- [26] Wheaton, B., Muthen, B., Alwin, D. F., & Summers, G. F. (1977). Assessing reliability and stability in panel models. *Sociological methodology*, 8, 84-136.
- [27] White, K. R., D. G. Clement, and P. Nayar. (2006). "Evidenced-Based, Healthcare Management Competency Evaluation: Alumni Perceptions." *Journal of Health Administration Education* 23 (4): 335-349.

## Engaging Students in Evaluating Films for a Disability Film Festival: Foundational Impacts

James P. Lawler

Pace University

New York City, New York 10038 USA

Community engagement with disadvantaged people is a goal of a university. The author of the paper describes the engagement of students as advocate agents of change in the evaluation of films for a disability film festival program at a leading metropolitan university. The program is fostering impacts of meaningful opportunities of outreach on both people with disabilities and students.

The film festival program is designed for discovering films of actual people with disabilities aspiring to be like people without disabilities. The films are focused on actual (not Hollywood) people with disabilities functioning in life despite impairments that often preclude them from society, from which other people with disabilities in the local neighborhoods are learning more of independent living possibilities in society. From engagement with film festivals, municipal organizations and non-profit organizations focusing on this population, the author describes the design of a diversity focus group of undergraduate students that is involved in the evaluation process for the films to be included in the program each spring. The author describes the empirically favorable impacts of the process on the students, most of whom do not have disabilities, in learning of people with disabilities and in marketing the program in the local neighborhoods of the university. In engagement with the students, the author describes further in this research-in-progress paper the favorable impacts of the program on the local people with disabilities. From the film festival program, the presence of the university is pronounced in its mission of improving the potential of an aspiring but often isolated population in society.

The impacts of the film festival program are high on the local people with disabilities at the program screenings and on the students participating in the process contributing to the screenings selected by them. The author describes the best of the films, identifying high impacts of respect on the students and of self-advocacy on the people with disabilities. The initial findings of this paper will benefit faculty of urban and non-urban universities considering the creativeness of film festival programs as a feasible proposition for expanding their readiness roles in improving opportunities for disadvantaged people and involving students in service with this population.

**GROSS STATE PRODUCT AND TECHNOLOGY EFFECTS ON HEALTHCARE  
EXPENDITURES IN U.S. STATES, 1991-2014**

Xiaohui You, James Madison University, 800 S Main Street, Harrisonburg, VA  
22807, 540-746-2956, youxx@jmu.edu

**ABSTRACT**

Changes in income and technology are the two major drivers of aggregate healthcare expenditures (HCE). This study, for the first time in the literature, presents econometric model estimates of the short- and long-run effects of income (Gross State Product) and technology proxies on healthcare expenditures (HCE) using alternative panel cointegration techniques applying for the 1991-2014 available update data for US state-level health expenditures. This study makes two novel contributions to the literature: first, it uses alternative panel unit root tests and the Westerlund ECM cointegration tests; second, it uses state-level data to model the determinant of HCE with panel cointegration technique. We detect long-run cointegration relationships among HCE, GSP, and the various measures of Research and Development (R&D) activities. To handle cross-sectional dependency, we applied the updated Bai FM and CUP-FM methods based on a factor model. Findings show the estimated income elasticities of HCE fall in the 0.60 to 0.97 range depending on the R&D measure employed, and that the upper bound of the technological change effect is 0.152. Since the US state-level health care is a necessity, subsidizing and providing access to care for low-income people as the Medicaid program could see dramatic achievement on welfare improving.

**JEL Codes:** I1

**Keywords:** healthcare expenditure; panel unit root and cointegration tests; income elasticity; technology effects, factor model, cross-sectional dependency

## **GROSS STATE PRODUCT AND TECHNOLOGY EFFECTS ON HEALTHCARE EXPENDITURES IN U.S. STATES, 1991-2014**

### **1. INTRODUCTION**

In 2017, U.S. health care expenditures (HCE) were \$3.5 trillion, 17.9% of gross domestic product (GDP); in 2018, they were \$3.65 Trillion in 2018, an increase of 4.4% over 2017, and things might get even worse. The report in the journal *Health Affairs* estimates an average annual growth rate of 5.5% from 2018 to 2027. To address skyrocketing health care costs, the Trump administration announced its plan to elicit more price transparency for medical care and initiatives. On January 11, 2018, the Trump administration allowed states to impose work requirements on Medicaid recipients, the low-income group, to cut off benefits for “able-bodied” recipients unless they have a job, are caregivers, or are in school.

Theoretically, as income increases healthcare spending tends to rise. There is a rich literature on the effect of real per capita GDP or income on HCE [37] [43, pp. 109-27] [44, pp. 671-687] [38, pp. 3-21] [20, pp. 20–29] [27, pp. 827-833] [36, pp. 367-374] [60, pp. 1023-1029]. Research using data for a large number of the world countries confirms that GDP explains a high percentage of the variance in HCE [8]. Knowing how health care behaves as income changes has policy implications in that detecting health care to be a necessity (that is, income elasticity is positive but less than one) could support arguments for public subsidies [16] [20, pp. 20–29] [19, pp. 207-225].

Moreover, modern technologies [17] [40, pp. 147-159] [23, No. 1469] [41, pp. 363-368] [59, pp. 263-272] [1] [35, pp. 67-73] [61, pp. 853-862] [42, pp. 327-358] enable patients to obtain clinically innovative diagnosis and treatments, in the forms of electronic information and communication systems, medical devices, drugs, and highly skilled (technology embodied) healthcare workers. Medical innovations are further linked to considerable improvements in the quality and longevity of life. As a result, past studies on the determinants of aggregate HCE across a large number of countries at various stages of economic development have linked changes in HCE to the changes in GDP, insurance, ageing population, and some specific or general technology (TECH) measures. However, there is no specific measure for technology effect on health care expenditures, different research uses different technology proxies or some other method, such as the residual component approach to address the technology effect.

Besides, researches exploring geographic variation in health spending is increasingly drawing greater attention in health economics and policy circles. The US federal and each state government play different roles in health services system design and delivery; the federal government is largely responsible for the Medicare program (covering those at least 65 years and the disabled) while funding of the Medicaid program (covering the indigent) is a partnership between federal and state governments [11]. Each of the 50 US states and the District of Columbia (DC) have established state specific health agencies that serve as the locus of state governmental public health activity. Their goals are to, within allowable limits of the specific waivers, modify certain features of the federal system to better serve population health needs at the various state levels. Since these states are legally and traditionally the primary authorities for public health, they have wide latitude and broad flexibility in defining their public health roles; therefore, federal policies influence but generally do not fully dictate state and local public health practices [51]. [15] argues that state-

specific factors, e.g., income and health care capacity are important factors when explaining state variations over time in the level of per capita personal health care spending. This reasoning justifies investigations in our study using state level, and not the aggregated national, data series.

Most studies on the determinants of HCE investigating the cointegration relationship (HCE, GDP, and TECH) used US national level aggregate data. This study is based on the less aggregated 1991-2014 US state level panel data to test for the existence of long run relationships among HCE, GSP (Gross State Product), and a number of TECH proxy measures.

This paper investigates the relationship among the US state level HCE, GSP, and the alternative technology measures (R&D expenditures and their components, such as graduates of science and engineering, and academic scientific articles published). With panel unit root and cointegration procedures, we estimate both the long run and short run relationships. Our work is the first in this line of inquiry to estimate the panel cointegration relationship among HCE, GSP, and alternative TECH measures using the latest US state level panel dataset. Here, the panel cointegration technique, an important scheme for avoiding spurious regression, is also a sound empirical strategy for handling potential cross-correlation and endogeneity issues.

Section 2 of this paper reviews pertinent literature on the determinants of aggregate HCE. Section 3 describes data sources and the variables. Section 4 on the empirical strategy includes the panel unit root and cointegration tests. Section 5 covers the empirical results. Finally, section 6 concludes with the implications of the study findings.

## **2. LITERATURE REVIEW**

GDP (or income) on the demand side and technological change on the supply side are the core determinants of aggregate HCE. Using panel unit root cointegration methods, previous research at the country level (see, Appendix Table A1) confirms that changes in GDP and technology have positive effects on variations in HCE. However, few studies have probed the possible cointegration relationship among HCE and its determinants at the less aggregated, state or provincial data level within a country.

Researchers have applied the cointegration approach with time-series data to estimate income and technology effects on US healthcare expenditures based on the stationarity assumption. Using 1960-1997 U.S. time-series data, [40] confirmed the long run relationship among HCE, per capita disposable income, and economy-wide R&D spending (as well as health sector R&D expenditures), using Johansen cointegration approach [30]. [18] also used time-series data to estimate U.S. aggregate HCE function using 1984-2006 data, with results supporting a cointegration relationship between GDP and HCE. More recently, [35], applying the Autoregressive Distributed Lag (ARDL) cointegration approach for modelling to 1960-2012 annual U.S. time-series data, found that per capita real income; population percent above 65 years and the level of health care technology exert positive effects on HCE in the long run.

Among the proxies for capturing technology change effects on US healthcare spending, the R&D spending has been found to be positive and significantly associated with HCE and GDP [35]. However, research is still lacking on whether a cointegration relationship exists among US state level HCE, GSP, and R&D, although studies have shown that there is cointegration relationship

between the state HCE and the state level GDP [2], and between the state level GDP and the state performed R&D [14] [10, working paper]. Past research also confirms the positive effect of the state level GDP on HCE, controlling for the federally funded industrial R&D spending [58].

Questions arise from the state level differences in activities and concentration of the state level R&D. Studies on US state level R&D suggest industrial R&D activity to vary by geographic location. Moreover, R&D activities appear to be concentrated among a few of the states [9] [62, pp. 286-293]. Moreover, there are broad mixes of R&D projects across the different states; some concentrate their activities in health, some in energy, and some in other sectors.

Therefore, whether the state level R&D expenditures also cointegrate with the state HCE and GSP is an interesting research policy question. For one reason, public policy can directly affect R&D expenditures, in turn, the returns to R&D investment, and innovations through development. Moreover, R&D spillovers or “knowledge spillovers” created by R&D investments confer positive external benefits to the entire society, especially to the neighboring states. This paper contributes to the literature on the short- and long-run relationships among the state-level HCE, GSP, and R&D expenditures, by applying an econometric methodology comprising of a range of techniques to test and estimate efficiently in a non-stationary panel data, solving both the cross-section dependence and the endogeneity problem.

### 3. DATA AND VARIABLES

This study uses 1991-2009 and 2009-2014 two datasets, the currently available panel time-series data of the 50 US states and the DC, as the State Health Expenditures (HCE) by state (The dependent variable in this study) with 2014 data are the available update. The State Health Expenditures (HCE) by the state of residence is constructed by adjusting the state of provider estimates for border-crossing patterns in consuming healthcare. Data were collected by the Centers for Medicare & Medicaid Services, Office of the Actuary, and National Health Statistics Group. The state level GSP data are from the US Bureau of Economic Analysis [29]. The US Bureau values may differ from the National Income and Product Account (NIPA) values because of revisions to the NIPA values as well as the GDP-by-state accounts excluding Federal military and civilian activity located overseas (because it cannot be attributed to a particular state). Data on Academic S&E R&D (\$thousands) per capita, Federal R&D obligations per employed worker, S&E graduate students, and Academic articles per \$1 million academic R&D, are collected from National Science Foundation/National Center for Science and Engineering Statistics, US Census Bureau, Governments. Annual Estimates of the Population for the States from the US Census Bureau, Population Division, are used for calculating per capita values (See Table 1: Data and Variables).

When using R&D as innovative technology input measure (using National Science Board Science and Engineering indicators 2014 state data tool), we considered six distinct R&D expenditures, but only three R&D expenditure measures, Federal R&D Obligation (RDF), Academic R&D (RDA), and R&D performed (RDP) are used in this study. Since the Federal R&D spending might crowd out the private sector R&D efforts in each state [58], it is important to include Federal R&D Obligation in this study. Private R&D activities in each state include Academic R&D (RDA) and R&D performed.

**Table 1: Data and Variables**

Label (In Logs)	Data	
	Description	Coverage
HCE <sup>1</sup>	Total personal health care spending per capita by state and by service	1991-2009, 2009-2014
GSP <sup>2</sup>	Gross state product per capita	1991-2009, 2009-2014
RDA <sup>3</sup>	Academic R&D per \$1,000 of Gross Domestic Product	1998-2009, 2009-2014
RDP <sup>3</sup>	R&D Performed	1991-2009, 2009-2014
RDF <sup>3</sup>	Federal R&D obligations per employed worker by state	1991-2009, 2009-2014
SEGRAD <sup>3</sup>	Science and engineering graduate students	1991-2009, 2009-2014
ARTICLE <sup>3</sup>	Academic articles per \$1 million academic R&D	1998-2009, 2009-2014
PATENT <sup>3</sup>	Patents/1,000 individuals in S&E occupations	1998-2009, 2009-2014
POP <sup>4</sup>	Annual Estimates of the Population for the States	1991-2009, 2009-2014

*Sources:*

- Centers for Medicare & Medicaid Services, Office of the Actuary, National Health Statistics Group.
- U.S. Bureau of Economic Analysis.
- National Science Foundation/National Center for Science and Engineering Statistics, U.S. Census Bureau, Governments.
- U.S. Census Bureau, Population Division.

**Table 2: Descriptive Statistics**

Data	Var.	HCE	GSP	RDA	RDP	RDF	SEGRAD	ARTICLE	PATENT
Data 1 1991- 2009	Mean	8.3574	10.413	4.8426	6.3167	5.2474	0.3851	-6.8737	-1.7131
	Stdv.	0.3414	0.3219	0.4803	0.8918	1.001	0.4553	1.0139	0.7687
	Obs.	969	969	612	946	969	969	612	357
Data 2 2009- 2014	Mean	8.480852	10.48624	13.13711	7.665624	6.040228	8.573515	1.407971	2.188721
	Stdv.	0.393805	0.340158	1.135030	1.495854	0.995791	1.112604	0.312505	0.661544
	Obs.	1224	1224	867	1200	1224	1224	867	1073

The state data convey state-specific information about a variety of technology, science, engineering, and education measures related to the state level R&D expenditures. This allows us to explore a single factor, R&D expenditures, in depth (both input and output factors), compare multiple factors for preselected groups and compare the changes over time. As for the R&D output factors, and Academic articles (ARTICLE), are included to infer the technological change effects on HCE. Interestingly, S&E graduate students (SEGRAD) can be alternatively treated as an output (of higher education institutions) or input (skilled human capital employed in the production of innovation) technology proxy. Again, though other variables do have updated data after 2014, our study has to limit the data coverage to 1991-2014 because of the state level healthcare expenditure data only available to 2014, some variables data coverage are 1998-2014.



## 4. THE MODELS

### 4.1 Empirical Methodology

The panel dataset studied contains 17 and 6 years of annual time series (time dimension  $T_1=17$  and  $T_2=6$ ) and 50 states and the DC (cross-section dimension  $N=51$ ). With  $T_1=17$  and  $T_2=6$  being less than 20, the time series is too short to estimate each time-series separately and test for heterogeneity, but the 17-year length is long enough for us to estimate the dynamic flexibility of the series. With  $N=51$ , the cross-section dimension is too large to be treated as a system to estimate VAR or VECM, but not so large as to fulfil the asymptotic requirement  $T/N \rightarrow 0$  for a number of the tests [24] [7, pp. 1-22] [6, pp. 1127-1177] [12, pp. 161-178] [28, pp. 48-53]. Thus, we need to choose appropriate methods to deal with this panel data in the sense of the heterogeneity, nonstationary, cross-sectional dependency, and endogeneity problems.

The first common problem in the context of panel non-stationary variables is, that most of the tests assume the absence of correlation across the cross-sections of the panel, with the assumption that the individual members of the panel (here, the 50 US states and the DC) are independent. This assumption is untenable, especially for those of the neighbour states, hence, [45] [46, pp. 967-1012] cross-section dependence test, a good approach to check the independence of the variables is estimated. Besides, Pesaran's CADF unit root test is applied to identify the stationarity and the PANICCA unit root test [6] is to check the nonstationary of common factor and idiosyncratic components for the cross-section series.

To test for the existence of a long-run cointegration among HCE, GSP, and a technology proxy, we employ the Error correction based [56] [57, pp. 665-704] cointegration tests since the residual based tests would tend to raise possibilities for spurious cointegration results if there is presence of cross-sectional dependency, as [53] suggested. Hence, the Westerlund ECM tests are included in the analysis of cointegration. After the cointegration test, the [56] tests based on the Error Correction Model (ECM) were estimated to check the panel cointegration on the assumption of weakly exogenous variables with a bootstrap technique deal with cross-sectional dependency (Result table is in Appendix). After the two Westerlund ECM tests, the Pesaran's CD test with the null hypothesis of no cross-sectional dependence in the panel data models was employed to check the cross-sectional independence with the residuals (Result table is in Appendix).

In sum, we confront the econometric issues usually neglected in earlier literature: first, we account for cross-section dependence and common factors among cross-section states variables on the tests. Second, to be prudent, we take alternative and more updated unit root tests into consideration, the Pesaran's panel CADF tests, the PANICCA unit root tests. Third, to test the cointegration relationship, we use the Westerlund ECM test. After the Westerlund ECM test, the dynamic panel error correction model (ECM) will be applied to estimate the short-run dynamics.

Finally, to identify the long-run relationship, we employ the cointegration procedure, which is known for adjusting the serial correlation and endogeneity problem. Meanwhile, the cross-section dependence in the residual is still problematic, the Bai FM (fully modified) is included in the analysis. Bai FM, CupBC (continuously-updated and bias-corrected), and CupFM (continuously-updated and fully-modified) procedures developed by [3] [4, pp. 82-99] based on the Factor model can overwhelm the cross-section dependency when variable in state  $i$  is non-spuriously correlated

with variable in state  $j$ , and when unobserved common factors among all states. Using a factor model to account for cross-sectional correlation and an information criterion to identify whether there is a factor or not [5] [6, pp. 1127-1177], Bai FM [3] estimates the fully modified estimator with a stationary factor while the updated CUP-FM and the CUP-BC [4] deal with the nonstationary factor. Estimations are based on the common factors decomposition that assures a homogeneous econometric approach. Given these points and the possible cross-sectional dependency issue, we focus more on the Bai FM and CupFM estimates; meanwhile, if no factor is present in the cross-section dimension, estimations provided from FMOLS approaches are useful and applicable, we will report the FMOLS estimation results.

## 4.2 Model Specification

### 4.2.1 Unit root tests

In general, the panel unit root tests are based on the following regression:

$$\Delta Y_{i,t} = \rho_i Y_{i,t-1} + \sum_{L=1}^{\rho_i} \phi_{i,L} \Delta Y_{i,t-L} + \alpha_i d_{it} + u_{it} \quad (1)$$

where  $i = 1, 2, \dots, N$  is individual, for each individual  $t = 1, 2, \dots, T$  time series observations are available,  $d_{it}$  is the deterministic component and  $u_{i,t}$  is the error term. The null hypothesis of the existence of a unit root for individual  $i$  is  $\rho_i = 0$ .

### The PANIC Approach

The Panel Analysis of Nonstationarity in Idiosyncratic and Common components (PANIC) method proposed by [6] uses a factor structure to investigate nonstationarity in panel data. The factor model is specified as follow:

$$X_{it} = c_{it} + \beta_i t + \lambda_i' F_t + e_{it} \quad (2)$$

$$(I - L)F_t = C(L)u_t \quad (3)$$

$$(1 - \rho_i L)e_{it} = D_i(L) \varepsilon_{it} \quad (4)$$

where  $X_{it}$  is the sum of a cross-section specific unit;  $c_{it}$ , constant;  $F_t$ , is a common factor component;  $\lambda_i'$ , is a loading factor;  $e_{it}$ , the error term, is the idiosyncratic component, which is stationary if  $|\rho_i| < 1$ ;  $L$ , the lag operator;  $D_{it}$ , is the deterministic component. The information criteria were employed to check the presence of a factor as [5] suggested, the PANIC approach allows us to identify the nonstationarity of the common factor.

### The PANICCA Test

Based on the PANIC approach and the cross-section average (CA) augmentation approach of [47] [48, pp. 94–115] [50, pp. 961–981] developed PANICCA, a combined approach that exploits the strengths of both CA and PANIC. The data-generating process (DGP) of  $Y_{i,t}$  is assumed to be given by the following common factor model:

$$Y_{i,t} = \alpha_i' D_{t,p} + \lambda_i' F_t + e_{i,t} \quad (5)$$

where  $e_{i,t}$  is a scalar idiosyncratic error,  $F_t$  is an  $r \times 1$  vector of common factors with  $\lambda'_i$  being the associated  $(r \times 1)$  vector of loading coefficients, and  $D_{t,p} = (1, \dots, t^p)'$  is a  $(p + 1) \times 1$  vector of trends, for which we consider two specifications: (i) a constant ( $p = 0$ ) and (ii) a constant and trend ( $p = 1$ ). In this paper,  $Y_{i,t}$  is considered as the variable of interest. However, we do allow for the presence of an  $m \times 1$  vector of additional variables, henceforth denoted  $X_{it}$ , whose DGP is given by

$$X_{it} = \beta'_i D_{t,p} + \Lambda'_i F_t + u_{it} \quad (6)$$

where  $u_{it}$  is an  $m \times 1$  vector of idiosyncratic errors. Since  $X_{it}$  is assumed to share the common factors of  $Y_{i,t}$  (the variable of interest), then the DGP for the combined variables becomes:

$$Z_{it} = B'_i D_{t,p} + C'_i F_t + V_{it} \quad (7)$$

where  $B'_i = (\alpha_i, \beta_i)$ ;  $C'_i = (\lambda_i, \Lambda_i)$  with  $r \times (m+1)$   $r \times (m+1)$  matrix dimension and  $V_{it} = (e_{i,t}, u'_{it})'$ . [50] note that since the first differenced  $Z_{it}$ , which eliminates any uncertainty regarding its order of integration, is used in the estimation process, then any existing method for common factor models can be used to estimate Eq. (7). [50] employs the CA approach. After estimation, the  $\widehat{F}_t$  and  $\widehat{e}_{i,t}$  are then tested for a unit root using the respective test equations:  $\widehat{e}_{i,t} = \rho \widehat{e}_{i,t-1} + \varepsilon_{i,t}$  and  $\widehat{F}_t = \rho \widehat{F}_{t-1} + \eta_t$  with the null hypothesis that  $\rho_1 = \rho_2 = \dots = \rho_N = 1$ . The test statistics of [6] are used in [50] to test for unit root in both  $\widehat{e}_{i,t}$  and  $\widehat{F}_t$ . There are three test statistics proposed for the unit root test of  $\widehat{e}_{i,t}$  each for  $p = 0$  and  $p = 1$  and are denoted as  $P_{a,p}$ ,  $P_{b,p}$  and  $PMSB_p$  [Panel Modified Sargan–Bhargava] tests. Their respective computations are given as:

For  $p = 0$ :

$$P_{a,p=0} = \frac{\sqrt{NT}(\widehat{\rho}_0^+ - 1)}{\sqrt{2\widehat{\phi}_\varepsilon^4 / \widehat{\omega}_\varepsilon^4}}; \quad P_{b,p=0} = \frac{\sqrt{NT}(\widehat{\rho}_0^+ - 1)}{\sqrt{\widehat{\phi}_\varepsilon^4 / [\widehat{\omega}_\varepsilon N^{-1} T^{-2} \sum_{i=1}^N (\widehat{e}_{i,-1}^0)' \widehat{e}_{i,-1}^0]}}; \\ PMSB_{p=0} = \frac{\sqrt{N}(N^{-1} T^{-2} \sum_{i=1}^N (\widehat{e}_{i,-1}^0)' \widehat{e}_{i,-1}^0 - \widehat{\omega}_\varepsilon^2 / 2)}{\sqrt{\widehat{\phi}_\varepsilon^4 / 3}} \quad (8)$$

For  $p = 1$ :

$$P_{a,p=1} = \frac{\sqrt{NT}(\widehat{\rho}_1^+ - 1)}{\sqrt{36\widehat{\phi}_\varepsilon^4 / 5\widehat{\omega}_\varepsilon^8}}; \quad P_{b,p=1} = \frac{\sqrt{NT}(\widehat{\rho}_1^+ - 1)}{\sqrt{6\widehat{\phi}_\varepsilon^4 \widehat{\phi}_\varepsilon^4 / [5\widehat{\omega}_\varepsilon^6 N^{-1} T^{-2} \sum_{i=1}^N (\widehat{e}_{i,-1}^0)' \widehat{e}_{i,-1}^0]}}; \\ PMSB_{p=1} = \frac{\sqrt{N}(N^{-1} T^{-2} \sum_{i=1}^N (\widehat{e}_{i,-1}^0)' \widehat{e}_{i,-1}^0 - \widehat{\omega}_\varepsilon^2 / 6)}{\sqrt{\widehat{\phi}_\varepsilon^4 / 45}} \quad (9)$$

where  $\varepsilon_{i,t}$ ,  $u_{it}$  and  $\eta_t$  are the respective innovations for the stationary AR(1) processes for  $e_{i,t}$ ,  $u_{i,t}$  and  $F_{i,t}$  and are independently and identically distributed across relevant data index(es) and  $\widehat{e}'_{i,-1} = (\widehat{e}_{i,2}, \dots, \widehat{e}_{i,T-1})'$ . The AR(1) coefficients -  $\widehat{\rho}_0^+$  and  $\widehat{\rho}_1^+$  are respectively computed as

$\hat{\rho}_0^+ = \hat{\rho}_0 + \frac{\hat{\tau}_\varepsilon}{NT^{-1} \sum_{i=1}^N (\hat{e}_{i,-1}^0)' \hat{e}_{i,-1}^0}$  and  $\hat{\rho}_1^+ = \hat{\rho}_1 + \frac{3\hat{\sigma}_\varepsilon^2}{T\hat{\omega}_\varepsilon^2}$  with  $\hat{\rho}_p$  obtained from the pooled AR(1) regression of  $e_{i,t}^p$  while  $\hat{\sigma}_\varepsilon^2$ ,  $\hat{\omega}_\varepsilon^2$ ,  $\hat{\phi}_\varepsilon^4$  and  $\hat{\tau}_\varepsilon$  are given by the cross-sectional averages of  $\hat{\sigma}_{\varepsilon,i}^2$ ,  $\hat{\omega}_{\varepsilon,i}^2$ ,  $\hat{\phi}_{\varepsilon,i}^4$  and  $\hat{\tau}_{\varepsilon,i}$  respectively. The asymptotic null distributions of  $P_{a,p}$ ,  $P_{b,p}$  and  $PMSB_p$  are detailed in [50]. The null hypothesis of a unit root in the idiosyncratic components of all panels is therefore tested via the  $P_{a,p}$ ,  $P_{b,p}$  and  $PMSB_p$  test statistics.

In testing for a unit root in  $\hat{F}_{i,t}$ , the test to apply is determined by the number of common factors. If only one common factor is to be estimated, then, testing can be carried out using any existing unit root test such as the augmented Dickey–Fuller which is suggested in [6]. Further, if at least two factors are estimated, as [52] suggested, that the iterative procedure of [6] would be applied and it would produce both the modified “filtered”  $Q_f[MQ_f]$  and the “corrected”  $Q_c[MQ_c]$  test.

#### 4.2.2 The Pesaran Cross-section dependence test

The [45] cross-section dependence (CD) test with the null hypothesis of zero dependence across the cross-section members with relatively short T and large N, with heterogeneous panels and with or without structural breaks.

The CD test statistic is defined as,

$$CD = \sqrt{\frac{2T}{N(N-1)}} \left( \sum_{i=1}^{N-1} \sum_{j=i+1}^N \sqrt{T_{ij}} \hat{\rho}_{ij} \right) \quad CD \rightarrow N(0, 1) \quad (10)$$

where  $\hat{\rho}_{ij}$  is the sample estimate of the pair-wise correlation of the OLS residuals,  $\hat{u}_{it}$ , such as

$$\hat{\rho}_{ij} = \hat{\rho}_{ji} = \frac{\sum_{t=1}^T \hat{u}_{it} \hat{u}_{jt}}{(\sum_{t=1}^T \hat{u}_{it}^2)^{1/2} (\sum_{t=1}^T \hat{u}_{jt}^2)^{1/2}}.$$

#### 4.2.3 Westerlund [56] ECM approach

$$\Delta HCE_{it} = c_i + a_{0i}(HCE_{i,t-1} - b_i X_{i,t-1}) + \sum_{j=1}^{K_{1i}} a_{1ij} \Delta HCE_{i,t-j} + \sum_{j=-K_{2i}}^{K_{3i}} a_{2ij} \Delta X_{i,t-j} + u_{it} \quad (11)$$

where  $a_{0i}$  is the error correction (or speed of adjustment) term. The penultimate term includes lags and leads of  $\Delta X$ ; otherwise, X is one or more exogenous variables.

#### 4.2.4 The panel error-correction specification

To examine the direction of causality between HCE and GSP, R&D factors, and to identify how the short-run response to the long-run steady state, we employ the dynamic panel error-correction specification proposed by [21],

$$\Delta HCE_{it} = \alpha_i^H + \sum_{k=1}^h \theta_{1i,k}^H \Delta HCE_{i,t-k} + \sum_{k=0}^h \theta_{2i,k}^H \Delta X_{i,t-k} + \lambda_i^H \varepsilon_{i,t-1}^H + u_{it}^H \quad (12)$$

$$\Delta X_{it} = \alpha_i^X + \sum_{k=1}^h \theta_{1i,k}^X \Delta X_{i,t-k} + \sum_{k=0}^h \theta_{2i,k}^X \Delta HCE_{i,t-k} + \lambda_i^X \varepsilon_{i,t-1}^X + u_{it}^X \quad (13)$$

where  $\Delta HCE_{it} = HCE_{it} - HCE_{i,t-1}$ ,  $HCE_{it}$  is the state HCE per capita for state  $i$  at year  $t$ ;  $\Delta X_{it} = X_{it} - X_{i,t-1}$ ,  $X_{it}$  is one of the cointegrating vectors. To be specific, the one two-vector model, five three-vector models, and one four-vector model are specified as follow:

Model M\_GSP:  $X_1$  is GSP (per capita gross state products);

Model M\_RDA:  $X_1$  is GSP; and  $X_2$  is a TECH vector, RDA (per capita academic R&D);

Model M\_RDF:  $X_1$  is GSP; and  $X_2$  is a TECH vector, RDF (Federal R&D per employed worker);

Model M\_SEG:  $X_1$  is GSP; and  $X_2$  is a TECH vector, SEGRAD (S&E graduate students);

Model M\_ART:  $X_1$  is GSP; and  $X_2$  is a TECH vector, ARTICLE (Academic articles per \$1 million academic R&D);

Model M\_PAT:  $X_1$  is GSP; and  $X_2$  is a TECH vector, PATENT.

Model M\_CRD:  $X_1$  is GSP;  $X_2$  is TECH1 proxy, RDF; and  $X_3$  is TECH2 proxy, RDP, to detect whether crowding out exists between public and private R&D expenditures in each state.

#### 4.2.5 The long run relationship specification

Using pool cross-section and time series data, we estimate the relationships between HCE, GSP, and technology factors, such as academic R&D, federal R&D, S&E graduate students, etc. for 50 states and DC in the U.S. using the equation:

$$HCE_{it} = \beta_0 + \beta_1 X_{1it} + \beta_2 X_{2it} + \dots + \beta_n X_{nit} + \varepsilon_{it} \quad (14)$$

where  $\beta_0$  is a constant term and  $\beta_n$  is estimated parameters in the model and  $i$  is a cross-section data for the state out of 51, and  $t$  is a time series data and  $\varepsilon_{it}$  is the error term.

## 5. EMPIRICAL RESULTS

### 5.1 Results from Stationarity and Unit root tests

**Table 3 1: Pesaran's CD and CADF statistics, 1991-2009**

Variable	CD dependence test	CADF panel unit root test
HCE	155.06***	-1.768
GSP	151.92***	-1.907
RDA	116.88***	-1.995
RDP	114.96***	NA
RDF	82.41***	-1.725
SEGRAD	67.99***	-1.462
ARTICLE	112.80***	-1.730
PATENT	48.81***	2.610***

Note:

1. \*, \*\*, or \*\*\* stands for rejection at 10%, 5%, or 1% level.
2. RDP fails on the CADF test due to the discontinuous data.

**Table 3 2: Pesaran's CD and CADF statistics, 2009-2014**

Variable	CD dependence test	CADF panel unit root test (level)	CADF panel unit root test (first difference)
HCE	79.60***	-1.824	-6.190***
GSP	79.87***	-1.999	-6.173***
RDA	82.59***	-1.754	-6.102***
RDP	81.98***	-1.516*	19.387***
RDF	77.80***	-2.154	-6.190***
ARTICLE	66.91***	-2.09	-6.035***
SEGRAD	82.80***	-1.92	-6.190***
PATENT	42.25***	-2.033**	19.387***

Note:

1. \*, \*\*, or \*\*\* stands for rejection at 10%, 5%, or 1% level.
2. RDP fails on the CADF test due to the discontinuous data.

**Table 4\_1: PANIC Unit root tests, 1991-2009**

Variable (First difference)	Factor		Idiosyncratic
	IC	Value	
HCE	1	0.2673 [-29.5386]	0.4371 [-28.0004]
GSP	1	-0.025 [-22.4521]	0.4716 [-18.9818]
RDA	1	-0.0574 [-18.684]	0.3626 [-22.0826]
RDP		NA	
RDF	0	-0.2308 [-32.377]	0.2753 [-29.3942]
SEGRAD	0	0.0499 [-20.4687]	0.5818 [-18.1081]
ARTICLE	1	-0.4913 [-15.6258]	0.2754 [-18.3429]
PATENT		NA	

Notes:

1. This table examines whether the variables are nonstationary with panel data set is for 50 states and DC and 1991 to 2009 (N=51, T=19).
2. The data is standardized, and test statistics are in [] under each value.
3. IC: information criterion from Bai and Ng (2002) indicating factors.
4. Rejection of the null hypothesis of unit root with test statistic less than -2.89.

**Table 4\_2. PANICCA test results for single variable, 2009-2014**

Variable (first difference)		Common Factors		Idiosyncratic Components					
		$p = 0$	$p = 1$	$P_{a,p}$	$p = 0$ $P_{b,p}$	$PMSB_p$	$P_{a,p}$	$p = 1$ $P_{b,p}$	$PMSB_p$
<b>hce</b>	Test Stat.	-6.083	-5.524	-11.194	-4.994	-1.986	-6.895	-4.168	-2.101
	P-value	0.000	0.000	0.000	0.000	0.024	0.000	0.000	0.018
<b>gsp</b>	Test Stat.	-6.710	-6.710	-46.999	-12.081	-2.836	-8.569	-5.041	-2.464
	P-value	0.000	0.000	0.000	0.000	0.002	0.000	0.000	0.007
<b>rda</b>	Test Stat.	-6.769	-6.748	-37.266	-9.990	-2.787	-6.411	-4.061	-2.236
	P-value	0.000	0.000	0.000	0.000	0.003	0.000	0.000	0.013
<b>rdf</b>	Test Stat.	-6.641	-6.622	-23.835	-7.923	-2.581	-26.951	-11.136	-3.388
	P-value	0.000	0.000	0.000	0.000	0.005	0.000	0.000	0.000
<b>article</b>	Test Stat.	-7.004	-6.990	-9.340	-4.369	-2.223	-2.202	-1.816	-1.284
	P-value	0.000	0.000	0.000	0.000	0.013	0.014	0.035	0.099
<b>seg</b>	Test Stat.	-6.978	-6.950	-34.151	-10.124	-2.850	-36.557	-13.243	-3.262
	P-value	0.000	0.000	0.000	0.000	0.002	0.000	0.000	0.000

Note:

1. The ADF-type test is used for the common factors while  $P_{a,p}$ ,  $P_{b,p}$  and  $PMSB_p$  are used for the idiosyncratic errors in the test equation for the variable.
2. The option  $p = 0$  refers constant only in the model while  $p = 1$  refers constant and trend.

Table 3\_1 (data 1991-2009) and 3\_2 (data 2009-2014) presents the results of Pesaran's variable (in level) CD test and CADF panel unit root tests (in level and first difference). The results clearly show that the null hypothesis of a panel unit root (nonstationary) in the level (Pesaran's CADF tests) of the series cannot be rejected (RDP and PATENT cannot be rejected at 1% level), while the null hypothesis of having panel unit root can be rejected in all series at the first difference form in CADF panel unit root test. Meanwhile, the results show that the null hypothesis of zero dependence across the cross-section members can be rejected from the Pesaran CD test, suggest the existence of the cross-section dependence for all the individual variables in level.

Meanwhile, the null hypothesis of having panel unit root can be rejected in all series at the first difference form in PANIC tests. Table 4\_1 (data 1991-2009) contains results of PANIC panel unit root test statistics for 6 (excludes RDP and PATENT) of the 8 variables. Missing values for RDP lead to failure of estimation for both Pesaran's CADF and PANIC unit root tests. The failure on the Pesaran's CADF test (Table 3\_1 and Table 3\_2) for PATENT may due to the relatively short data coverage.

Table 4\_2 (data 2009-2014) contains the results of PANICCA panel unit root test statistics for 6 of the 8 variables (first difference). Though missing values for RDP and PATENT leads to failure of estimation for PANICCA unit root tests, the results of the panel unit root tests reject the hypothesis of a unit root in the rest of variables (first difference) across states. This indicates that stationarity in the variables (first difference) with both the common factors and idiosyncratic errors as all the statistics are statistically significant. In other words, results indicate that all variables are

I (0), stationary after one-time differencing with the constant in the panel unit root tests. These results allow our estimations to move on to the next step, panel cointegration tests.

## 5.2 Results from panel Co-integration Tests

### 5.2.1 Results from the Westerlund test:

To test for the existence of a long-run cointegration among state level HCE, GSP, and the technology proxies, Westerlund [56] ECM panel cointegration tests were employed. The underlying idea for the Westerlund tests is to test for the absence of cointegration by determining whether the individual panel members are error correcting or not (Model M\_CRD with a bootstrap technique) to eliminate the cross-sectional dependency. In addition, using reverse regression tests, the Westerlund Weak Exogenous tests help to check the null hypothesis of error correction.

Results (Table 5\_1 with data 1991-2009 and 5\_2 with data 2009-2014) from the computed values of the Westerlund ECM panel cointegration statistics show that the null hypotheses of no cointegration are rejected for 5 out of 6 models, fail to reject for M\_CRD. For model M\_CRD with bootstrapping size 100, the no cointegration null was rejected for  $G\alpha$  and  $P\alpha$  at the 5% level but fails for both  $G\tau$  (group mean) and  $P\tau$  (Panel mean). Hence, there is evidence of the cointegration relationship for state level HCE, GSP, and the technology proxy in these 7 models.

**Table 5\_1: Results from Westerlund ECM panel cointegration tests, 1991-2009**

Model	Test Stat.	$G_\tau$	$G_\alpha$	$P_\tau$	$P_\alpha$
<b>M_GSP</b>	Value	-5.902	-29.686	-17.199	-33.792
	Z-value	-31.529	-19.097	-2.458	-29.696
	P-value	0.000	0.000	0.007	0.000
<b>M_RDA</b>	Value	-1.783	-10.349	-11.302	-9.604
	Z-value	-2.735	-5.910	-3.470	-10.353
	P-value	0.003	0.000	0.000	0.000
<b>M_RDF</b>	Value	-1.107	-3.999	-5.949	-2.494
	Z-value	1.869	2.383	0.559	0.007
	P-value	0.969	0.991	0.712	0.503
<b>M_SEG</b>	Value	-0.691	-1.795	-3.575	-1.311
	Z-value	4.704	5.262	2.345	1.731
	P-value	1.000	1.000	0.991	0.958
<b>M_ART</b>	Value	-2.293	-11.369	-15.061	-9.981
	Z-value	-6.208	-7.242	-6.299	-10.902
	P-value	0.000	0.000	0.000	0.000
<b>M_PAT</b>	Value	-3.489	-2.345	-4.331	-1.933
	Z-value	-14.363	4.543	1.777	0.825
	P-value	0.000	1.000	0.962	0.795
	Robust P-val	0.280	0.000	0.320	0.020
<b>M_CRD</b>	Value	-1.486	-7.401	-7.674	-6.062
	Z-value	1.556	0.469	1.320	-2.026
	P-value	0.940	0.680	0.907	0.021
	Robust P-val	0.310	0.000	0.250	0.000

Note: Bootstrapping size 100.



**Table 5\_2: Results from Westerlund ECM panel cointegration tests, 2009-2014**

Model	Test Stat.	$G_{\tau}$	$G_{\alpha}$	$P_{\tau}$	$P_{\alpha}$
<b>M_GSP</b> (HCE, GSP)	Value	-4.249	-35.188	-17.479	-35.097
	Z-value	-11.344	-21.242	-11.577	-28.667
	P-value	0.000	0.000	0.000	0.000
<b>M_RDA</b> (HCE, GSP, RDA)	Value	-3.408	-26.529	-14.992	-28.575
	Z-value	-6.145	-11.440	-7.678	-16.746
	P-value	0.000	0.000	0.000	0.000
<b>M_RDF</b> (HCE, GSP, RDF)	Value	-4.029	-32.687	-16.822	-33.203
	Z-value	-8.928	-15.489	-9.450	-20.159
	P-value	0.000	0.000	0.000	0.000
<b>M_ART</b> (HCE, GSP, ART)	Value	-3.875	-31.808	-16.049	-31.939
	Z-value	-8.239	-14.910	-8.702	-19.227
	P-value	0.000	0.000	0.000	0.000
<b>M_SEG</b> (HCE, GSP, SEG)	Value	-3.227	-23.311	-15.587	-29.207
	Z-value	-5.339	-9.325	-8.254	-17.212
	P-value	0.000	0.000	0.000	0.000
<b>M_PAT</b> (HCE, GSP, PATENT)	Value	-0.378	-1.983	-4.257	-2.963
	Z-value	12.850	8.131	7.725	3.707
	P-value	1.000	1.000	1.000	1.000
	Robust P-val	0.890	0.130	0.000	0.000
<b>M_CRD</b> (HCE, GSP, RDF, RDP)	Value	-0.112	-0.056	-0.579	-0.259
	Z-value	16.073	11.076	12.430	7.842
	P-value	1.000	1.000	1.000	1.000
	Robust P-val	0.990	0.017	0.130	0.023

Note:

1. Variables included are in parenthesis under each model.
2. Bootstrapping size 100.

To check the weak exogeneity assumption, using a series of reverse regression tests, results with the HCE as independent variable suggest that, the null of no error-correction cannot be rejected for all variables in all 7 models except for RDP in Model\_CRD according to the Robust p-value (with at least two statistics out of the four statistics insignificant at 5% level of significance). The discontinuous RDP data series might be the reason for the failed weak exogeneity test, or there is also possible that RDP is a strong exogenous variable in the model while other variables are weak exogenous variables.

### 5.2.2 Results from the Pesaran CD test:

Two types of Pesaran's Cross Sectional dependence Tests (CD Test) are employed to test the cross-sectional dependency for the variable and the panel data models. In Table 3, the Pesaran CD tests of the individual variable in level indicate the existence of the cross-section dependence. In addition, the results of Pesaran's residual CD tests for these 6 models all reject the null hypothesis of no cross-sectional dependence. Results for the average absolute correlation of the off-diagonal elements of the cross-sectional correlation matrix of residuals are ranging from 0.402 to 0.607, which suggests strong cross-sectional dependence for these models under the FE specification.

**Table 6\_1: Results from Panel Error Correction Estimation, 1991-2009**

Model	M_GSP	M_RDA	M_RDP	M_RDF	M_SEG	M_ART	M_PAT	M_CRD
<b>Normalized cointegrating coefficients</b>								
HCE (-1)	1	1	1	1	1	1	1	1
GSP (-1)	-1.298 [-14.862]	-1.432 [-16.448]	-0.285 [-8.145]	-0.337 [-9.792]	-0.585 [-18.481]	-0.930 [-112.291]	-1.263 [-11.176]	-0.857 [-6.572]
TECH1 (-1)		-0.036 [-0.606]	-0.855 [-14.953]	-0.931 [-13.655]	-6.456 [-8.606]	-1.520 [-13.692]	0.097 [1.058]	-0.336 [-5.953]
TECH2 (-1)								-0.119 [-3.636]
TREND (1)								0.00005 [0.461]
C	5.063	6.673					4.860	3.218
<b>Adjustment coefficients</b>								
D (HCE)	-0.112 [-1.824]	0.020 [0.652]	0.022 [1.350]	0.018 [1.680]	0.004 [1.229]	0.034 [2.012]	0.069 [1.319]	-0.184 [-3.418]
D (GSP)	0.782 [9.079]	0.762 [15.084]	0.284 [9.609]	0.134 [7.024]	0.046 [8.118]	0.462 [14.910]	0.266 [3.000]	0.524 [5.662]
D (TECH1)		0.578 [5.057]	1.283 [12.609]	1.108 [13.572]	0.092 [8.138]	0.587 [8.873]	-2.195 [-6.347]	0.077 [0.210]
D (TECH2)								0.954 [2.371]
Log likelihood	546.770	883.878	364.368	197.987	1025.866	924.403	666.716	1953.880

Note: t-statistics are in [].

### 5.3 Estimations of short-run relationship

The co-integrating vectors arising from the models require normalization, so that the adjustment and co-integrating vectors can be given plausible economic interpretations (Table 6\_1: Results from Panel Error Correction Estimation, 1991-2009). Take the result of M\_GSP for example, given t-1 time-series HCE and GSP, when setting HCE (-1) as one, the coefficient of GSP (-1) and the constant are -1.298 and 5.063, respectively. The negative coefficient for GSP (-1) is not suggesting a negative relationship between HCE and GSP in the short run, but to be specific, to shows that the lag value of GSP is 1.298 lower than the long run equilibrium value. The increase

growth on per capita HCE is associated with a 1.298 lower per capita GSP rate, on average, in one-year period. The adjustment parameters,  $\alpha$ , -0.112 and 0.782 correct for  $\Delta$ HCE, and  $\Delta$ GSP, respectively, negative for HCE while positive for GSP, pulling the value of GSP back towards its long-run equilibrium value with HCE, 11.2% corrected by HCE itself and 78.2% by GSP.

For the technology proxy models, the coefficients of TECH1 (-1) are negative for RDA, RDP, RDF, SEGRAD, and ARTICLE, but positive for PATENT. As for two TECH proxies model, M\_CRD, both coefficients of TECH (-1) (RDF) and TECH2 (-1) (RDP) are negative, no sign of crowding out in the short run. These results show a rise in R&D spending is associated with decreased HCE in one-year period, so do the academic output (ARTICLE) and the human capital (SEGRAD, S&E graduates).

**Table 6 2: Results from Panel Error Correction Estimation, 2009-2014**

Model	M_GSP	M_RDA	M_RDF	M_SEG	M_ART	M_PAT	M_CRD
<b>Normalized cointegrating coefficients</b>							
HCE (-1)	1	1	1	1	1	1	1
GSP (-1)	-1.842 [-20.537]	0.831 [ 7.155]	-2.624 [-21.631]	-6.285 [-13.905]	-1.742 [-20.724]	0.060 [ 0.552]	-0.322 [-1.275]
TECH1 (-1)		-1.192 [-26.408]	0.926 [ 20.048]	4.205 [ 23.236]	-0.301 [-3.835]	-1.330 [-20.027]	-1.730 [-23.568]
TECH2 (-1)						1.609 [ 16.046]	1.609 [ 16.046]
TREND (1)							0.0001 [0.461]
C	10.867	-1.741	13.439	21.408	10.235	-6.238	-1.404
<b>Adjustment coefficients</b>							
D (HCE)	0.054 [ 2.758]	-0.093 [-12.976]	0.044 [ 3.676]	0.021 [ 10.620]	0.049 [ 2.464]	-0.080 [-7.236]	-0.038 [-9.021]
D (GSP)	0.376 [ 11.749]	-0.105 [-7.732]	0.115 [ 5.602]	0.023 [ 5.992]	0.392 [ 12.175]	-0.108 [-5.282]	-0.028 [-3.621]
D (TECH1)		1.161 [ 19.455]	-0.967 [-12.953]	-0.303 [-18.189]	0.073 [ 2.262]	0.845 [ 17.394]	0.683 [ 15.585]
D (TECH2)							-0.194 [-6.435]
Log likelihood	428.561	526.696	432.671	515.562	431.635	413.922	493.376

Note: t-statistics are in [].

According Table 6\_2: Results from Panel Error Correction Estimation, 2009-2014, for M\_GSP, given t-1 time-series HCE and GSP, when setting HCE (-1) as one, the coefficient of GSP (-1) and the constant are -1.842 and 10.867, respectively. The negative coefficient for GSP (-1) is not suggesting a negative relationship between HCE and GSP in the short run, but to be specific, to shows that the lag value of GSP is 1.842 lower than the long-run equilibrium value. The increasing growth on per capita HCE is associated with a 1.842 lower per capita GSP rate, on average, in a one-year period. The adjustment parameters,  $\alpha$ , -0.054 and 0.376 correct for  $\Delta$ HCE, and  $\Delta$ GSP,

respectively, negative for HCE while positive for GSP, pulling the value of HCE and GSP back towards its long-run equilibrium value, 5.4% corrected by HCE itself and 37.6% by GSP.

For the technology proxy models, the coefficients of TECH1 (-1) are negative for RDA, ARTICLE, and PATENT. As for two TECH proxies model, M\_CRD, the coefficient of TECH (-1) (RDF) is negative and that of TECH2 (-1) (RDP) is positive, there is a sign of crowding out in the short run. These results show a rise in the academic R&D is associated with decreased HCE in a one-year period, so do the academic output articles (ARTICLE) and the patent awarded; the Federal obligation R&D spending is positively associated with HCE in a one-year period in the three vectors model, so does the S&E graduates (SEG). The short-run positive effect (4.205) of S&E graduates on HCE highly exceeds those of other technology proxies, the rising of S&E graduates positively affects the growth of HCE in the short run. Interestingly, researchers actually found out that on the R&D investment process, more than half the cost was related to the wages and salaries of trained scientists and engineers with their productivity reduced in periods of short-term job contractions [34].

#### 5.4 Estimations of long run relationship

The key finding in this empirical exercise is the presence of a long run cointegration relationship among HCE, GSP, and the specific TECH (technology) factors. For comparison, the long-run relationships between real per capita HCE, GSP, and technology progress were estimated using 5 Methods (FMOLS, LSDV, Bai FM, CUP-BC, and CUP-FM; See Appendix A4: Results for long-run relationship estimations.). Given the evidence on cross sectional dependency, we focus our attention on the Bai FM, CUP-BC, and CUP-FM estimates [3] [4, pp. 82-99], which are based on the factor model and PANICCA unit root tests [5] [6, pp. 1127-1177] [50, pp. 961– 981] to check the presence of a factor in the panel as well as nonstationarity in the series. The difference between Bai FM, CUP-BC, and CUP-FM is whether the factor is stationary or not; Bai FM estimator has a stationary factor, while CupBC and CupFM deal with the nonstationary factor by estimating the parameters and long-run covariance matrix once (CUP-BC) or recursively (CUP-FM) until convergence.

The PANICCA method was employed to identify nonstationarity and if the series is pervasive due to the common factor or series specific to the individual series [12]. Results from the PANIC and PANICCA method (Table 4\_1 and 4\_2) show that both the common factors and the idiosyncratic component are stationary for 6 out of 8 variables, HCE, GSP, RDA, and ARTICLE (No programming results for PATENT and RDP). Hence, Bai FM approach would be more suitable than CUP-BC and CUP-FM for analyzing the long-run relationship between HCE and GSP and technology proxies for most of the models.

The seven estimated models in this study, six models with at least three cointegrating vectors (HCE, GSP, and Technology proxy) and one model, M\_GSP, with two cointegration vectors, can form a cointegrating relationship among the vectors. If one of the cointegrating vectors has no factor with the cross-sectional dimension or fail to apply to PANICCA regression due to data problem (such as PATENT and RDP), Bai FM and CUP-FM are still appropriate approaches to employ. To be prudent, for Model\_PAT and Model\_CRD containing PATENT and RDP without the PANICCA results, FMOLS estimations are good alternatives in the sense of comparison.

**Table 7\_1: Long-run relationship results from Bai FM Estimation, 1991-2009**

Variables	Models							
	M_GSP	M_RDA	M_RDP	M_RDF	M_SEG	M_ART	M_PAT	M_CRD
<b>GSP</b>	0.871*** [32.825]	0.955*** [54.986]	0.908*** [34.925]	0.651*** [21.269]	0.788*** [28.349]	0.806*** [33.571]	0.638*** [21.411]	0.624*** [19.124]
<b>RDA</b>		0.002 [0.93]						
<b>RDP</b>			-0.007*** [-2.626]					0.0004 [0.182]
<b>RDF</b>				0.052*** [6.716]				0.052*** [6.64]
<b>SEGRAD</b>					0.270*** [9.199]			
<b>ARTICLE</b>						0.011 [1.306]		
<b>PATENT</b>							-0.024*** [-7.307]	

Note: *t*-statistics are in [ ].

**Table 7\_2: Long-run relationship results from Bai-FM Estimation, 2009-2014**

Variables	M_GSP	M_RDA	M_RDF	M_SEG	M_ART	M_PAT	M_CRD
<b>GSP</b>	0.918 [41.171]	0.599 [20.516]	0.793 [32.220]	0.718 [8.607]	0.971 [46.299]	0.79 [40.771]	0.178 [28.302]
<b>RDA</b>		0.152 [9.611]					
<b>RDF</b>			0.061 [10.737]				0.012 [2.379]
<b>SEG</b>				0.011 [9.310]			
<b>ARTICLE</b>					0.016 [2.209]		
<b>PATENT</b>						0.07 [39.422]	
<b>RDP</b>							0.059 [11.830]

Note: *t*-statistics are in [ ].

Table 7\_1 results (data 1991-2009), on Bai FM estimation for the long run, show that technology change effects are almost positive on HCE except for RDP and PATENT. Increased Academic R&D spending (RDA) and Federal R&D (RDF) expenditures are, respectively associated with greater HCE. As expected, Science and Engineering graduate students (SEGRAD) and published articles (ARTICLE) have significantly positive long run effects on HCE with 0.27 (significant) and 0.011 (insignificant) coefficients, respectively. The performed R&D (RDP), on the contrary,

is negative and statistically significantly related to HCE (-0.007), so does the number of PATENT (-0.024, significant). Intuitively, the negative effects of state performed R&D on HCE provide the evidence of the hot debated R&D issue, spillover effects. As for PATENT, we tend to prefer the results from CUP-FM than that of Bai FM because of the problems raised from the short data coverage and no factor of model M\_PAT.

Table 7\_2 shows the Long-run relationship results from Bai FM Estimation, 2009-2014. Given that the common factor is stationary, when removing the cross-section dependency, real per capita HCE clearly increase with per capita real GSP with income elasticity 0.817 for M\_GSP, which suggests that healthcare, in the 50 US states DC, is a necessity good, not luxury good as previous finding based on aggregate US national level data suggested. According to estimation results from long run relationships (See Appendix A4: Results for long-run relationship estimations), income elasticities in all models in this study are lower compared with past findings based on aggregated US data (national level). This may partly arise from differences in data period coverage and the different sources of data used. When applying multilevel models with different data, health care is an individual necessity and a national luxury as [26] suggests.

Table 7\_2 results on Bai FM estimation for the long run show that technology change effects are all positive on HCE. Increased Academic R&D spending (RDA), academic output factors, such as published articles (ARTICLE), Science and Engineering graduate students (SEGRAD), and patents awarded (in Table 8), are associated with increasing HCE. As for model M\_CRD (crowding out effects), results from FMOLS and CUP-FM suggest that there is crowding out effect between state performed R&D and Federal R&D in the long run, with the growth of RDF significantly decreases HCE by 0.056 per year and RDP increases the growth of state level health care expenditures in the long run by 0.007 though insignificant, according to the FMOLS estimates (in Table 8). Since the performed R&D (RDP) is positively related to HCE (0.007, statistically insignificantly), there is no evidence of spillover effects, the negative effect of state performed R&D on HCE.

**Table 8: Long-run relationship results from FMOLS Estimation, 2009-2014**

Variables	M_GSP	M_RDA	M_RDF	M_SEG	M_ART	M_PAT	M_CRD
GSP	0.817 [817.03]	0.782 [65.78]	0.848 [122.60]	0.832 [101.03]	0.809 [161.98]	0.795 [210.12]	0.845 [112.02]
RDA		0.028 [2.95]					
RDF			-0.053 [-4.47]				-0.056 [-4.35]
SEG				-0.017 [-1.74]			
ARTICLE					0.067 [1.84]		
PATENT						0.099 [5.91]	
RDP							0.007 [0.80]

Note: t-statistics are in [ ].

## 5.5 Discussion on short- and long- run effects

Our results suggest the existence of short- and long-run variations in the technology effects, variously measured, on HCE. Per capita Federal R&D expenditures (RDF) and human capital (SEGRAD) drive up the growth of state-level HCE in both the short run and long run. The magnitudes of the short-run coefficients of SEG are very large, compared with those for the long-run, which suggests that one-year period effects are highly significant from the Science and Engineering graduate students, the human capital effect. Since the human capital in the US can be easily mobile across states, it is understandable that the Science and Engineering graduate students in one state will move to other states, especially the neighbor states in a short time. The number of S&E graduates has a positive long-run effect on HCE as well (Table 7), which suggests that high-grade human capital with the accumulated knowledge and skills is nonrival and nonexcludable in the long run and can result in economy-wide increasing productivity. Indeed, S&E graduates have highly mobile employment opportunities across the US states after graduation, which generates positive spillovers just as the public R&D funding [49]. As for the RDF, the Federal obligation R&D expenditure decision may not come from the state government based on state budget condition and Health and Human Services is just one of six agencies performed the Federal obligation R&D, which makes it impossible to have common pattern and specific trend across states. Thus, along with the growth of the performed R&D expenditure (positive effects on HCE) in the M\_CRD, Per capita Federal R&D expenditures (RDF) show negative effects on the state healthcare spending in both short run and long run, implies the crowding-out effect.

As we are investigating the relationship of the HCE, GSP, and TECH for both short run and long run, estimations for academic R&D, academic articles, and patents have negative effects in short run but positive in the long run, which makes sense that the growth rate of those variables are lower than that of the HCE on one-year period, however, in the long run, increasing of those TECH variables is driving up the growth of HCE significantly.

## 6. CONCLUSION

Using 1991-2009 and 2009-2014 panel data of the US states and the DC, we investigated short- and long-run relationships between per capita health care expenditures (HCE), per capita GSP (GSP), and specific technology proxies (TECH). Employing panel cointegration techniques, we found evidence for one cointegrating relationship among those vectors for both datasets. The GSP elasticities of HCE (ranging from 0.60 to 0.97) suggest that healthcare is a necessity (could be justification for publicly subsidized healthcare, e.g. Medicaid and premium subsidy under 2010 U.S. Affordable Care Act). In theory, with government subsidy, the broader access to health services could be expected to produce positive net social benefits. Meanwhile, we find that there is break before and after 2009, the effect of technology proxies are different from the two datasets.

Depending on the nature of medical innovation, the technological change effect variously measured (0.152 or less) is not always a positive driver of HCE [55]. One possible reason is that R&D innovative effects may take a relatively long time to realize. We see clearly that the long run technology effects are positive for all of the technology measures, while the short run technology effects differ (positive or negative) a lot for different proxies. To be specific, for the long run, all technology proxies positively affect the growth of HCE (except for Federal obligation R&D in the

M\_CRD model) in each state; while in the short run, the effects of R&D output measures, academic articles and patents awarded, with negative effects.

Before 2009, the output factors of R&D, such as academic articles and patents awarded, have positive effects on HCE in both the long- and short- run. After 2009, the input factors, such as Science & Engineering graduates are always positive in both short- and long-run; Output factors, such as academic articles and patents awarded, positive in the long-run while negative in the short-run. Those findings confirm the important role of the government in subsidizing R&D and protecting intellectual property. Although some specific technology proxies, R&D output factors, such as academic articles and patents awarded in each state might be capable of lowering HCE through cost-beneficial R&D spillover effects in the short run, technological progress as a whole can positively affect HCE in the long run.



# **Appendix**

<b>A1. Previous studies on health care expenditure using panel data</b>				
<b>Article</b>	<b>Model</b>	<b>Data</b>	<b>Variables</b>	<b>Finding</b>
[39]	Unit root tests	Time series and panel data for OECD countries; 1960-1997	GDP and health care expenditures	Estimated the unit root tests for both time series and the panel data and found that income elasticity greater than one.
[13]	Panel unit root and stationarity tests	OECD countries; 1960-1997	Health care expenditure and GDP	Health care expenditure and GDP are stationary around a broken trend.
[22]	Panel cointegration	21 OECD countries; 1975-2001	Health expenditure and GDP, life expectancy, infant mortality, and the share of the elderly	A cointegration relationship can be established among variables; health care expenditures are not a luxury good.
[23]	OLS and pooled fixed effect regressions	EU15 and RAMS countries; Projecting for 2007-2060	Public health care expenditure, demographic structure, income, health status of the population, and technical trend	A very wide dispersion in the trend growth rate of health-care expenditure at individual country level.
[31]	Standard fixed effects and dynamic models	143 developing countries; 1995-2008	Total health expenditure, government health expenditure, and out-of-pocket payments; share of GDP, demographic factors, and tax-based and insurance-based health financing mechanisms.	Health expenditure in general does not grow faster than GDP, and no difference in health expenditure between tax-based and insurance-based health-financing mechanisms.
[19]	Panel co-integration	30 OECD countries; 1990-2009	Health care expenditures and income and non-income variables	Health care expenditure is highly inelastic and income elasticity is much small when mainly financed by government.
[25]	Panel cointegration and causality in VECM framework	Developing countries; 1990-2009	Health care expenditure and GDP and economic growth	There is a bilateral causality and long-run relationship between economic growth and health spending.
[33]	Panel cointegration	13 MENA countries; 1995-2005	Health expenditure and GDP	Both health expenditure and GDP are non-stationary and co-integrated, and health care is not a luxury good in MENA countries due to the negative relationship between the share of health expenditures to GDP and GDP.
[53]	Westerlund panel cointegration test, and Continuous-Updated Fully Modified (CUP-FM) estimator	ECO countries; 1995-2009	Healthcare expenditure and GDP, population below 15 and above 65 years old, number of physicians, and urbanization	There is long-term relationship between those variables and health is a necessary good in ECO countries
[54]	Granger causality tests with Vector autoregressive (VAR) model	30 developed countries; 1975-2011	The real per capita health care expenditure (HCE) and real per capita GDP	Bidirectional Granger causality is predominant the causality between the real per capita health care expenditure (HCE) and real per capita GDP.
[32]	Unit root tests	14 EU countries; 1975-2008	Health care expenditures of EU member states relative to the EU average	There is unit root for the health care expenditures of most EU member states relative to the EU average.

---

**REFERENCES**

- [1] Abrantes-Metz, RM. 2012. The Contribution of Innovation to Health Care Costs: At Least 50%? Available at SSRN: <http://ssrn.com/abstract=2121688> or <http://dx.doi.org/10.2139/ssrn.2121688>
- [2] Altarum Institute. 2015. Health Sector Economic Indicators<sup>SM</sup> Insights from Monthly National Health Spending Data Through June 2015. 2015. *Altarum Institute Spending Brief #15-8: June 2015 data.*
- [3] Bai J, Kao C. 2006. On the Estimation and Inference of a Panel Cointegration Model with Cross-Sectional Dependence. *Contributions to Economic Analysis* 274: 3-30.
- [4] Bai J, Kao C, Ng S. 2009. Panel cointegration with global stochastic trends. *Journal of Econometrics* 149: 82-99.
- [5] Bai J, Ng S. 2002. Determining the number of factors in approximate factor models. *Econometrica* 70: 191-121.
- [6] Bai J, Ng S. 2004. A panic attack on unit roots and cointegration. *Econometrica* 72:1127-1177.
- [7] Bai J, Perron P. 2003. Computation and analysis of multiple structural change models. *Journal of Applied Econometrics* 18 (1): 1-22.
- [8] Baltagi BH, Lagravinese R, Moscone F, Tosetti E. 2016. Health care expenditure and income: A global perspective. *Health Economics* DOI: 10.1002/hec.3424 (forthcoming).
- [9] Bennof RJ. 2002. Half the Nation's R&D Concentrated in Six States. *Science Resources Statistics* NSF02-322.
- [10] Blancco L, Prieger J, Gu J. 2013. The Impact of Research and Development on Economic Growth and Productivity in the US States, *Pepperdine University School of Public Policy Working Papers.*
- [11] Bovbjerg RR, Wiener JM, Housman MG. 2003. State and Federal Roles in Health Care: Rationales for Allocating Responsibilities. *Federalism and Health Policy*, Washington, DC: The Urban Institute Press.
- [12] Breitung J. 2000. The local power of some unit root tests for panel data. In B. Baltagi (Ed.), *Nonstationary Panels, Panel Cointegration, and Dynamic Panels, Advances in Econometrics* 15: 161-178.
- [13] Byrne JP. 2008. The Global Dimension to Fiscal Sustainability. *Scottish Institute for Research in Economics SIRE-DP-2008-14.*
- [14] Corey J. 2009. Development in US States, Economic Freedom, and the "Resource Curse". *Fraser Institute Studies in Mining Policy.*
- [15] Cuckler G, Sisko A. 2013. Modeling per capita state health expenditure variation: State-level characteristics matter. *Medicare & Medicaid Research Review* 3(4).
- [16] Culyer AJ. 1988. Health care expenditures in Canada: Myth and reality; past and future, *Tax Paper 82, Canadian Tax Foundation.*
- [17] Cutler DM. 1995. Technology, health costs, and the NIH. In *National Institutes of Health Roundtable on the Economics of Biomedical Research.*
- [18] Das A, Martin F. 2010. An Econometric Analysis of the US Health Care Expenditure. *Global Journal of Health Science* Vol. 2 No. 1.
- [19] de Mello-Sampayo F, de Sousa-Vale S. 2014. Financing health care expenditure in the OECD countries: evidence from a heterogeneous, cross-sectionally dependent panel. *Panoeconomicus* 2: 207-225.

- [20] Demetriades PO, James GA. 2011. Finance and growth in Africa: The broken link. *Economics Letters*, Elsevier **113** (3): 263-265.
- [21] Di-Matteo L. 2003. The income elasticity of health care spending: A comparison of parametric and nonparametric approaches, *The European Journal of Health Economics* 4: 20–29.
- [22] Dobnik F. 2011. Energy Consumption and Economic Growth Revisited: Structural Breaks and Cross-section Dependence. *Ruhr Economic Papers* #303.
- [23] Dreger C, Reimers HE. 2005. Health Care Expenditures in OECD Countries: A Panel Unit Root and Cointegration Analysis. *IZA Discussion Paper* No. 1469.
- [24] Dybczak K, Przywara B. 2010. The role of technology in health care expenditure in the EU. *European Commission Directorate-General for Economic and Financial Affairs*, Economic Papers 400.
- [25] Eberhardt M. 2011. Panel time-series modeling: New tools for analyzing xt data. *2011 UK Stata Users Group meeting*.
- [26] Elmi ZM, Sadeghi S. 2012. Health Care Expenditures and Economic Growth in Developing Countries: Panel Co-Integration and Causality. *Middle-East Journal of Scientific Research* **112** (1): 88-91.
- [27] Getzen TE. 2000. Health care is an individual necessity and a national luxury: applying multilevel decision models to the analysis of health care expenditures. *Journal of Health Economics* **19**: 259-270.
- [28] Getzen, TE and Okunade, AA. 2016. Symposium introduction: Papers on ‘Modeling National Health Expenditures’. *Health Economics* DOI: 10.1002/hec.3405 (forthcoming).
- [29] Greenaway-McGrevy R, Han C, Sul D. 2010. Asymptotic distribution of factor augmented estimators for panel regression. *Journal of Econometrics* **169**: 48-53.
- [30] Gross Domestic Product by State Estimation Methodology. 2006. *Bureau of Economic Analysis U.S. Department of Commerce*.
- [31] Hadri K. 2000. Testing for stationarity in heterogeneous panel data. *Econometrics Journal* **3**(2): 148–161.
- [32] Im KS, Pesaran MH, Shin Y. 2003. Testing for unit roots in heterogeneous panels. *Journal of Econometrics* **115** (1): 53–74.
- [33] Jessup A. 2012. Health Care Cost Containment and Medical Innovation, *Office of Science and Data Policy, ASPE*.
- [34] Johansen S. 1991. Estimation and hypothesis testing of cointegration vectors in Gaussian vector autoregressive models. *Econometrica* **59** (6): 1551-1580.
- [35] Johansen S. 1995. Likelihood-based inference in cointegrated vector autoregressive models. *Oxford: Oxford University Press*.
- [36] Ke X, Saksena P, Holly A. 2011. The Determinants of Health Expenditure: A Country-Level Panel Data Analysis. *World Health Organization, Working paper*.
- [37] Keung Lau MC, Terence Fung KW. 2014. Convergence in Health Care Expenditure of 14 EU Countries: New Evidence from Non-linear Panel Unit Root Test. *Munich Personal RePEc Archive* No. 52871.
- [38] Koijen RSJ, Philipson TJ, Uhlig H. 2014. Financial Health Economics. *NBER Working Paper* No. 20075.
- [39] Levin A, Lin CF, Chu CS. 2002. Unit root in panel data: Asymptotic and finite-sample properties, *Journal of Econometrics* **108** (1): 1-24.

- [40] Mehrara M, Fazaeli AA, Fazaeli AA, Fazaeli AR. 2012. The Relationship between Health Expenditures and Economic Growth in Middle East & North Africa (MENA) Countries. *Mohsen Mehrara et al, Int.J.Buss.Mgt.Eco.Res* **3** (1): 425-428.
- [41] Mulkay B, Hall BH, Mairesse J. 2000. Firm Level Investment and R&D in France and the United States: A comparison. *NBER Working Paper Series Working Paper* 8038.
- [42] Murthy VNR, Okunade AA. 2016. Determinants of U.S. health expenditure: Evidence from autoregressive distributed lag (ARDL) approach to cointegration. *Economic Modelling* **59**: 67-73.
- [43] Narayan PK, Narayan S. 2008. Does Environmental Quality Influence Health Expenditures? Empirical Evidence from a Panel of Selected OECD Countries. *Ecological Economics* **65**: 367-374.
- [44] Newhouse JP. 1977. Medical care expenditure: A cross-national survey. *Journal of Human Resources* **12**: 115-125.
- [45] Newhouse JP. 1992. Medical care costs: How much welfare loss? *Journal of Economic Perspectives* **6**(3): 3-21.
- [46] Okunade AA, Karakus M. 2001. Unit root and cointegration tests: Time-series versus panel estimates for international health expenditure models. *Applied Economics* **33** (9): 1131-1137.
- [47] Okunade AA, Murthy VNR. 2002. Technology as a 'major driver' of health care costs: a cointegration analysis of the Newhouse conjecture. *Journal of Health Economics* **21**: 147-159.
- [48] Okunade, A.A. 2004. Concepts, measures, and models of technology and technical progress in medical care and health economics. *Quarterly Review of Economics & Finance* **44**(3): 363-368.
- [50] Okunade AA, You X, Koleyni K (2018) Cross-country Medical Expenditure Modeling Using OECD Panel Data and ARDL Approach: Investigating GDP, Technology and Ageing Effects. *Health Econometrics in Contributions to Economic Analysis*, Emerald Publishing.
- [51] Parkin D, McGuire A, Yule B. 1987. Aggregate Health Care Expenditures and National Income: Is Health Care a Luxury Good. *Journal of Health Economics* **6**: 109-27.
- [52] Peden EA, Freeland MS. 1998. Insurance Effects on US Medical Spending (1960-1993). *Health Economics* **7**: 671-687.
- [53] Pesaran MH. 2004. General diagnostic tests for cross section dependence in panels. *CESifo Working No.* 1229.
- [54] Pesaran MH. 2006. Estimation and inference in large heterogeneous panels with a multifactor error structure. *Econometrica* **74** (4): 967-1012.
- [55] Pesaran MH. 2007. A simple panel unit root test in the presence of cross-section dependence. *Journal of Applied Econometrics* **22** (2): 265-312.
- [56] Pesaran HM, Smith LV, Yamagata T. 2013. Panel unit root test in the presence of a multifactor error structure. *Journal of Econometrics* **175**: 94-115.
- [57] Popp D. 2015. Using Scientific Publications to Evaluate Government R&D Spending: The Case of Energy. *NBER Working Paper Series Working Paper* 21415.
- [58] Ramirez MD. 2006. A Panel Unit Root and Panel Cointegration Test of the Complementarity Hypothesis in the Mexican Case, 1960-2001. *Economic Growth Center No.* 942.
- [59] Reese, S., & Westerlund, J. (2016). PANICCA: PANIC on cross-section averages. *Journal of Applied Econometrics*, **31**, 961-981.

- [60] Salinsky E. 2010. Governmental Public Health: An Overview of State and Local Public Health Agencies. *National Health Policy Forum*. Background Paper No. 77.
- [61] Salisu AA. 2019. United we stand, divided we fall: A PANICCA test evidence for stock exchanges in OECD. *Finance Research Letters*. 28: 343-347.
- [62] Samadi A, Rad EH. 2010. Determinants of Healthcare Expenditure in Economic Cooperation Organization (ECO) Countries: Evidence from Panel Cointegration Tests. *International Journal of Health Policy and Management* **1**(1): 63-68.
- [63] Sargan JD, Bhargava A. 1983. Testing residuals from least squares regression for being generated by the Gaussian random walk. *Econometrica* **51**(1): 153-74.
- [64] Sghari MBA, Hammami S. 2013. Relationship between Health Expenditure and GDP in Developed Countries. *IOSR Journal of Pharmacy* **3** (4): 41-45.
- [65] Smith, S. 2016. Technological Innovation in Health Care: A Global Perspective, in Richard Scheffler, Ed. *Global Handbook of Health Economics and Public Policy*. Singapore: World Scientific Publishing Company.
- [66] Westerlund J. 2007. Testing for error correction in panel data. *Oxford Bulletin of Economics and Statistics* **69**: 709-748.
- [67] Westerlund J, Edgerton DL. 2008. A simple test for cointegration in dependent panels with structural breaks. *Oxford Bulletin of Economics and Statistics* **70** (5): 665-704.
- [68] Wong A, and Wouterse B, and Slobbe LCJ, Boshuizen HC, Polder JJ. 2012. Medical innovation and age-specific trends in health care utilization: Findings and implications. *Social Science & Medicine* 74: 263-272.
- [69] Woodward RS, Wang L. 2011. The Oh-so straight and narrow path: Can the health care expenditure curve be bent? *Health Economics* **21** (8): 1023-1029.
- [70] You X, Okunade AA. 2016. Income and technology as drivers of Australian healthcare expenditures. *Health Economics* DOI: 10.1002/hec.3403 (forthcoming).
- [71] Zeile WJ. 2013. State-Level R&D by Multinational Companies Results From an Interagency Data Link Project. *Survey of Current Business Research Spotlight*: 286-293.

**DECISION SCIENCES INSTITUTE**  
Healthcare Provider Recommendation Engine

**ABSTRACT**

In this study, we propose a multi-criteria decision-making approach for matching patients and healthcare providers. The proposed approach features the characteristics of goal programming and location covering models to provide recommendations to patients based on rating, distance, and appointment lead times. The model can be used for developing or improving upon existing methods to improve public health outcomes, reduce health disparities, and broaden access to healthcare.

From a patient perspective, we focus on three criteria including minimizing distance, minimizing appointment lead time, and maximizing the provider rating. We compile three datasets: one with patient data, another one with healthcare provider data, and a third one with the distance of the Cartesian product of all. Data mining techniques are used to enhance the provider dataset by geocoding, adding ratings, and adding capacities. For geocoding and calculating real driving distances, we used programming languages like Visual Basic in addition to Application Program Interfaces (APIs) provided by Microsoft Bing. After implementing missing value imputation techniques, we obtained data to be used in the proposed optimization model. The multi-objective optimization model has been converted into a linear integer programming model using weights for each criterion of individual patients. For our demonstration purpose we generated the weights using an excel formula, but while implementing the model we may request patients to provide their preferred weights for each criterion. Then the resulting optimization model is solved by SAS OptModel Procedure. Model is tested with sanitized patient data and results are presented.

Working with a data set of 200+ patients and 100+ providers, we used a multi-criteria decision-making algorithm to accomplish the request. Future work would include having additional criteria, GIS integration, real-time data feed, and integration with a healthcare provider database. Future research direction is to lay out the foundation of a back-end recommendation application that public health departments could use behind a front-end application. The foundation of this model can be applied to virtually any field that requires a matching system.

**KEYWORDS:** Healthcare, Optimization, Matching, Provider Ratings, Recommendation

## Improving Firefighting Traceability Processes with RFID Technology Application

### Abstract

Firefighting is a unique profession. It requires hazard engagement rather than hazard avoidance. Within such responses, firefighters may be exposed to numerous threats such as dense smoke, extreme noise and heat from the flames, confined spaces, or collapsing structures. These environmental factors make navigation for the firefighters very difficult, often resulting in confusion and disorientation. In an attempt to prevent these tragedies, it is critical to track a responder's movements within the emergency and disastrous environment. Such tracking ability will assist firefighters within the building to escape serious threats or in the event of a mayday call, assist their team in completing a rescue. This has led to the development of various technologies and search methods to improve safety standards during an emergency response, one of which is RFID.

The purpose of this research was to identify an RFID-based traceability system that could accurately track a firefighter's location during an emergency response and determine the practicality of implementation within the fire services. A case study was conducted by collecting data from several fire stations in Lethbridge, AB, Canada. Business Process Reengineering (BPR) approach was undertaken for analysing the results. Information via in-person interviews and surveys were gathered to the gain expert insight into the theory of implementing a tracking technology for their fire services, as well as understanding the equipment standards for their working conditions.

This research has investigated several scenarios for the proper placement of the RFID tag as the results of interviews and surveys. The recommended scenario is using an active RFID tag, to be sewn on the interior left side of their coats, on the back of their upper arm. This spot is preferable because the technology would not impact the firefighter's mobility, be the most protected from the environment, as well as the responder's movements, remain assigned to a specific individual as the coats are not shared and remain on a piece of equipment that is unlikely to be removed.

As a further step to this research, the fourth stage of BPR will be investigated by looking into practical sides of application of the proposed traceability system. For this means, the testing of the proposed technology at a Lethbridge Fire Station is being considered. The researchers will also explore the capability to determine vertical location of firefighters within a structure for a more accurate location navigation.



## **MEDICAL SCHOOL - BUSINESS SCHOOL COLLABORATION FOR QUALITY IMPROVEMENT TRAINING AND RESEARCH**

Ashley Y. Metcalf, Ph.D., 514D Copeland Hall, College of Business, Ohio University, Athens, OH 45701, 1-740-593-9170, [metcalfa@ohio.edu](mailto:metcalfa@ohio.edu)

### **ABSTRACT**

Physicians and other healthcare leaders are under increasing pressure to know the fundamentals of Leadership, Patient Safety and Quality Improvement. Because of this pressure, there is a recent growth in opportunity for collaboration between business schools and medical schools to fill the gap. In this paper, I discuss the drivers and benefits of this collaboration as well as an example of collaboration using root cause analysis.

### **INTRODUCTION**

Healthcare professionals need business skills in order to provide high-quality clinical care and still achieve the organization's goals. Physicians are commonly recognized and promoted based on their clinical expertise. However, physicians especially need skills in leadership and other areas of management that are expected in their jobs beyond clinical expertise [2], [3], [4]. According to the NEJM, "Regardless of whether future physicians decide to work in a large healthcare system or solo practice, they will need fundamental knowledge and skills in three key business disciplines: leadership, teamwork, and data analytics" to provide high quality care at lower cost [2]. According to HBR, "Even though medical institutions have designated "leadership" as a core medical competency, leadership skills are rarely taught and reinforced across the continuum of medical training. As more evidence shows that leadership skills and management practices positively influence both patient and healthcare organization outcomes, it's becoming clear that leadership training should be formally integrated into medical and residency training curricula" [3].

Meanwhile, business faculty at AACSB-accredited business schools are under increasing pressure to show industry engagement, research with impact, and relevance to their respective specialty areas. Business faculty may use consulting or other forms of industry engagement to try to fill this need. Furthermore, business faculty are commonly looking for ways to collect data or access data for their research projects.

Physicians and medical faculty affiliated with ACGME-accredited medical schools recognize the need to develop their own skills and teach medical students and residents topics such as leadership and quality improvement. Doesn't this sound like a ripe opportunity for collaboration between business faculty and medical schools?

In addition, ACGME-accredited medical residency programs are required to keep their faculty (physicians) trained up on topics such as leadership and quality improvement. Furthermore,

medical residents are expected to learn quality improvement methodologies and participate in teams, such as a root cause analysis team or other quality improvement team [1]. In Figure 1, you can see the ACGME Common Program Requirements (effective July 1, 2019) for medical residency programs as it relates to quality improvement learning outcomes [1].

### **EXAMPLE OF ROOT CAUSE ANALYSIS PROJECTS**

Many major universities have both a medical school and a business school. And, for business schools that do not have a direct affiliation with a medical school, there is likely a medical school within a relative short geographical distance, which allows for networking opportunities. Business faculty with expertise in quality improvement should consider reaching out to their local medical schools and determine their current needs and challenges in teaching quality improvement topics to medical students and medical residents. This simple step opens the door for speaking engagements, research collaboration, and applied learning.

In my experience, I offered several unpaid speaking engagements to medical students, medical faculty and residents at my university's medical school. My talks centered around the need for quality improvement in healthcare and the associated techniques. The outcome of those talks then lead to engagement with an affiliated medical residency program at a hospital in Ohio. The residency program was trying to teach their residents how to perform root cause analysis projects in multi-functional teams, but their faculty had never been formally trained on the topic themselves. When I became part of their program, I was able to teach their faculty root cause analysis (RCA) techniques, evaluate the various RCA projects performed by medical residents, and create a plan for improving the teaching methods. I teach tools like Fishbone diagrams, 5Whys, and A3 reports. But, I would argue, more importantly, I teach physicians the importance of systems-thinking, not just clinical-thinking. Systems thinking can be quite difficult for physicians, since they view their work through the lens of clinical needs of patients. Lastly, I have been able to work with the medical faculty for starting several research papers.

Involvement with the medical residency program has led to several very positive outcomes: *First*, medical faculty, physicians, and residents benefit from training by a business faculty with quality improvement specialty. *Second*, the business faculty gets involved in industry, is able to claim relevant impact, and is able to see the application of their techniques in practice. *Third*, the medical faculty and business faculty can co-author research related to the collaboration and the root-cause analysis outcomes. *Fourth*, the hospital (or other healthcare facility) benefits directly from the outcomes of the RCA projects, which can identify systematic problems or failures that need to be corrected.

## **VI.A. Patient Safety, Quality Improvement, Supervision, and Accountability**

VI.A.1. Patient Safety and Quality Improvement All physicians share responsibility for promoting patient safety and enhancing quality of patient care. Graduate medical education must prepare residents to provide the highest level of clinical care with continuous focus on the safety, individual needs, and humanity of their patients. It is the right of each patient to be cared for by residents who are appropriately supervised; possess the requisite knowledge, skills, and abilities; understand the limits of their knowledge and experience; and seek assistance as required to provide optimal patient care. Residents must demonstrate the ability to analyze the care they provide, understand their roles within health care teams, and play an active role in *system improvement processes*. Graduating residents will apply these skills to critique their future unsupervised practice and effect quality improvement measures.

VI.A.1.a).(3).(b) Residents must participate as team members in real and/or simulated interprofessional clinical patient safety activities, such as *root cause analyses* or other activities that include analysis, as well as formulation and implementation of actions.

### VI.A.1.b) Quality Improvement

VI.A.1.b).(1) Education in Quality Improvement A cohesive model of health care includes quality-related goals, tools, and techniques that are necessary in order for health care professionals to achieve quality improvement goals.

VI.A.1.b).(1).(a) Residents must receive training and experience in quality improvement processes, including an understanding of health care disparities.

VI.A.1.b).(2) Quality Metrics Access to data is essential to prioritizing activities for care improvement and evaluating success of improvement efforts.

VI.A.1.b).(2).(a) Residents and faculty members must receive data on quality metrics and benchmarks related to their patient populations.

VI.A.1.b).(3) Engagement in Quality Improvement Activities Experiential learning is essential to developing the ability to identify and institute sustainable *systems-based changes* to improve patient care.

VI.A.1.b).(3).(a) Residents must have the opportunity to *participate in interprofessional quality improvement activities*.

Figure 1: ACGME, *Common Program Requirements (Residency)*, 2019 [1]

## CONCLUSIONS

Medical schools and residency programs have a growing need in teaching and in application of quality improvement principles. Business faculty have a growing need to show impact to practice and gain access to data for research. Using a collaborative approach between medical faculty and business school faculty can create a win-win environment for everyone involved. I would encourage business school faculty to consider this type of outreach as a part of their planning process for future education and research initiatives.

## REFERENCES

- [1] ACGME (2019). Accreditation Council for Graduate Medical Education: Common Program Requirements (Residency), accessed December 6, 2019, available at <https://www.acgme.org/Portals/0/PFAssets/ProgramRequirements/CPRResidency2019.pdf>
- [2] Pearl, R.M., & Fogel, A.L. (2017). New Physicians Will Need Business School Skills. NEJM Catalyst, accessed December 6, 2019, available at <https://catalyst.nejm.org/new-physicians-need-business-school-skills/>
- [3] Rotenstein, L.S., Sadun, R., & Jena, A.B. (2018). Why Doctor's Need Leadership Training. Harvard Business Review, accessed December 6, 2019, available at <https://hbr.org/2018/10/why-doctors-need-leadership-training>
- [4] Stoller, J.K (2018). Developing Physician Leaders: A Perspective on Rationale, Current Experiences, and Needs. *CHEST*, 154(1), 16-20.

## **NURSING SURVIVAL TRAITS: PREPPING TO RETAIN**

Gary Hackbarth, Langdale College of Business Administration, Valdosta State University, 1500 North Patterson Street, Valdosta, GA 31698, 229-245-3805, ghackbarth@valdosta.edu

Matthew Kolakowski, Langdale College of Business Administration, Valdosta State University, 1500 North Patterson Street, Valdosta, GA 31698, 229-253-2912, mjkolakowski@valdosta.edu

### **ABSTRACT**

Preparation and survival traits afford nurses adaptability in a continually evolving healthcare landscape. Nurses that “prep” are employees who strive to learn, network, and express family values. To assess the potential organizational value of “prepper” nurses, we analyzed 1,171 newly licensed Registered Nurses in a 2014-2015 Cohort pulled from the Inter-university Consortium for Political and Social Research (ICPSR). Results indicated that nurses with “prepper” traits, 94.3% of respondent’s self-report good to excellent health, and 76.3% of nurses self-reported intent to stay with their current employer. Results indicate that “prepper” nurses are a critical resource to the healthcare system.

**Key Words:** Prepper, Survivor, Healthcare, Nursing, Personality Traits

### **INTRODUCTION**

Successful nurses are caring, empathetic, detail-orientated, organized, emotionally stable, adaptable, have physical and mental endurance, be quick thinkers, hard-working, and excellent communicators [22]. A longitudinal study of 192 English hospital nurses measured nursing values identified four groups with unique characteristics: “The Soldiers,” “Cheerful Professionals,” “High Achievers” and “Highly Stressed” [5]. The “Highly Stressed” are likely to turnover with indicators of psychological stress and difficulty coping with nursing challenges. The “Soldiers” are among those who stay and deal with numerous financial cuts and worsening nurse-patient ratios. They seem to have the survivalist trait to remain calm in the face of the storm through preparation and training. “Cheerful Professionals” can improvise and fix problems as they cope with upwardly mobile careers and a variety of challenges. “High Achievers” have a strong personality and a commitment to nursing values.

Appreciating and understanding nurses who possess the temperament to survive is essential. Survivors exist in a society where expectations are too much or are people who have survived under extraordinary circumstances. Survivors tend to stay calm in the face of danger, are adept at improvisation, exhibit a positive attitude, possess mental toughness and a strong work ethic. Furthermore, nurses that demonstrate “prepper” and survivalist traits could have lower than average turnover rates [4]. Nurses that exhibit “prepper” and survivalist traits have a 23.7% two-year turnover intent in comparison to 51% of the “non-prepper” population [10]. Turnover of healthcare employees, especially Registered Nurses (RN), is a widely used measure to analyze the healthcare organizational environment and predict job growth in the future. When a healthcare employee decides to leave, other employees tend to follow, causing workload increases for remaining employees and an impact on the quality of patient care [10].

Compdata analyzed 11,000 healthcare employers with more than 11 million employees, and found that the average turnover in healthcare jobs in 2017 was 20.7%, up from 15.6% in 2010 [18]. Health professionals may leave because of burnout from staffing shortages, overwork from being assigned too many tasks, lack of upward mobility, poor management, they no longer enjoy the job, have an unhealthy work/life balance, or perceive underpayment [4]. Financial implications for nursing turnover range from \$5.2 to \$8.1 million per hospital annually indicate that “prepper” and survivalist traits, if analyzable during the hiring process, could reduce this cost over time [22]. This cost extrapolated over the 6,210 hospitals in the United States equates to \$31.67 billion lost due to nursing turnover in 2015 [3]. This study discusses and posits that nurses who have a penchant or exhibit “prepper” or survivalist behavior tend to have increased intent to stay, physical health, and willingness to self-select for continuing education.

### **LITERATURE REVIEW**

Nursing requires certain personality traits to cope with a stressful and demanding job. Role competence and patient safety competence among healthcare professionals is vital in an era of increasing patient acuity and complexity in the healthcare system [9]. Resilience positively correlated with extroversion and conscientiousness. Resilient psychiatric nurses tend to have higher job satisfaction and felt they had a higher professional status [16]. Resilience negatively correlates with neuroticism, openness to new experiences, and agreeableness [12].

Functional turnover due to incompetence would indicate a poorly functioning employee likely to be discharged or encouraged to change jobs. Clinically competent nurses would be aware of clinical guidelines, nursing interventions, and principles of nursing care. Professional competence would suggest high ethical standards, strong decision-making skills, development work, and the ability to collaborate [1]. Bagley et al. (2018) identified four groups: “The Soldiers” (N = 79), with medium scores on most measures, who bravely “soldier on” in their nursing roles, in the face of numerous financial cuts to the National Health Service, and worsening nurse-patient ratios; “Cheerful Professionals” (N = 54), coping successfully with nursing roles, and a variety of challenges, in upwardly mobile careers; “High Achievers” (N = 39), senior nurses with strong profiles of a “hardy personality,” and commitment to fundamental nursing values; and “Highly Stressed, Potential Leavers” (N = 20), with indicators of significant psychological distress, and difficulty in coping with nursing role challenges [6].

The survival way of orientating to a crisis is to feel entirely responsible for making things work out well [20]. An employee with a survival personality is self-determined, in control, doesn’t panic, can pause and consider before acting, sees a crisis as a challenge, is creative, works with tenacity [21]. Survivors create workable solutions that often ignore established rules and procedures but remain in the context of existing family values. Personality traits exemplified by survivors include the courage to face the unknown, and ability to improvise, a tendency to Do-It-Yourself (D.I.Y.), and the ability to make tough decisions to support the people around them [18]. They have a thirst for knowledge that they pursue to gain one more skill or one more fact that might make a difference later [15]. They exhibit compassion for others, a high degree of mental and physical fitness, the ability to negotiate, as well as exhibiting an optimistic outlook.

They have critical thinking skills, know the value of networking, and lead others to overcome obstacles [15].

The prepper mindset evolved from the survivalist movement. Preppers are those who prepare in advance for foreseen and unforeseen problems. Prepping is one-way people create a sense of safety in an unstable world [22]. Preppers cannot predict the loss of a job or downfall of an organization, but they can be ready if it occurs. Preppers would have a wide range of transferable skills, and express an attitude that if the organization fails, they will be the last employee out the door locking it behind them [22]. Employees often know in advance what projects are going to fail or organizations are in trouble. The prepper identity requires they be self-sufficient, self-disciplined, savvy, responsible, knowledgeable, and better equipped to survive than others in a generalized culture [22]. Preppers focus on making themselves ready and prepared to meet organizational challenges [2].

### *Comparison of Survival, Prepper and Nursing Traits*

Healthcare is experiencing a shortage of qualified nurses. Some nurses leave because of incompetence, but others leave for a variety of reasons related to salary, burnout, and the need to move to survive elsewhere. Nursing qualities, values, and beliefs are studied to select those best able to be nurses. Rarely do we consider why they stay. Rarely, do we ask how they prepare to survive in an environment where burnout from long hours, demanding work, and low pay are the norm? The idea of survival in the nursing profession is not about staying alive in the extreme but more like I'm going to have a job no matter what. If everyone else quits, I'm going to be the one still here. Table 1 synthesizes the shared beliefs and values common to nursing, preppers, and survivalists.

Table 1: Comparison of Survival, Prepper and Nursing Traits

<b>Survivors</b>	<b>Preppers</b>	<b>Nurses</b>
Will to Survive Thirst for Knowledge	Will to Live Responsible	Training Thirst for Knowledge Technological Savvy
Read the New Reality	Thirst for Knowledge Lifetime Learner	Ability to Adapt Innovators
Do it Yourself (DIY) Improvisation	Self-sufficient Adaptability Ingenuity	Communicative Compassionate
Open to Do Anything	Thrifty Networking	Resilient

While the nursing literature does not directly posit survivalist and “prepper” traits impacting turnover, it does lend itself to be extended theoretically in this direction. Survivors read the new reality and take responsibility for what is happening and are confident in their ability to deal with whatever comes next. Survivors expect to survive and never doubt their ability to survive. Preppers prepare for events that may never occur and know they will be surprised, but again, as

with survivors, never doubt their ability to overcome. Nurses have the confidence to deal with emergencies from doing their job and dealing with patients under difficult circumstances but rarely consider issues related to their employment. Failure in crisis may lead to the loss of life; however, too many failures questions their professional competency and could lead to job loss or legal exposure.

Survivors, preppers, and nurses all have a thirst for knowledge. Survivors use all of their life competencies to bear on the problem of survival. Preppers have a thirst for knowledge and are lifetime learners. The thought process is that you cannot predict what is going to happen in the future or what little scrap of information might be valuable later. Nurses are trained to be competent in dealing with emergencies and gold standard care. They develop a body of knowledge related to nursing. Being technologically savvy was a trend in nursing and a skill set to acquired to be competent on the job [6]. For most nurses, the mind-set is that this skillset was needed to do the job rather than learn this skill to keep my job and survive fluctuations in the job market later. Survivors can adapt to changing circumstances and use what they must survive [20]. In that moment of need, the opportunity to prepare for the survival moment no longer exists. The survivor must improvise, become ingenious, and use what resources are available [20]. In a first aid emergency, you may or may not have the ideal resources to treat a patient. First-aid is about problem-solving and treating a patient in such a way that the patient is and able to be transported to proper care facility. In this context, nurses and survivalists are much the same.

#### *Comparison of Survival, Prepper and Nursing Intellectual and Emotional Traits*

Compassion is a necessary value or belief for nurses. The dynamic of compassion changes once the job is on the line, and the focus is on survival. How am I going to survive the downsizing or restructuring? The context is once again situational. There is little compassion to spare for others when I am losing my job is well. While one might feel compassion for others in the same boat, there must be a singular focus on taking care of myself and my family. Companies under-going business process change initiatives had better success when they repurposed employees into new jobs. Employees (survivors) were promised new posts in the company if they would agree to retrain and provide support for the initiative. Survivors had little compassion for employees unwilling to retrain to meet the requirement of the new reality.

Survivors and preppers place great store in being physically and mentally able to meet the challenges of the unknown. Perhaps the lack of emphasis on physical and mental fitness is part of the cause of nursing burnout. Physically fit nurses might deal with stress better if they were more fit. There are links that physicalness is related to emotional strength. It is a skill needed to prioritize what skills and resources are in a survival situation. Once they are in survival mode, the competencies they have, are the ones that they will use. There is no time to become more competent. Success as a survivor, nurse, and preppers are about setting priorities.

Survivors act and show others what to do. Planning is primarily a prepper activity. Preppers are not requiring, or others follow their lead. Nurses can be leaders or managers, but nurses can also be followers in that they follow the lead of doctors and more experienced nurses to avoid risk and the fallout from potential bad decisions. It may be that survivors and preppers may be



exceptional mentors. Mentors train and advise employees on how to manage careers, avoid career minefields, and understand the unwritten rules of the organization. A successful mentor, by definition, would be a survivor.

## METHODOLOGY

Research data came from the Inter-university Consortium for Political and Social Research (ICPSR). Data was the Newly Licensed Registered Nurse New Cohort 3 Survey that studied newly licensed registered nurses who obtained their first license to practice between August 1, 2014, and July 31, 2015. This survey interviewed nurses about their jobs, turnover, education, intentions, and attitudes (including intent, satisfaction, organizational commitment, and preferences about work) [14].

### *Summary Statistics*

There were 1,171 newly licensed nurses from the United States in the survey. 13.5% of the survey participants were male, and the other 85.5% were female. Nurses less than 29 years 54.4%, 30-39 years 27.2%, 40-49 years, 4.4% over 50 years of age. 41.9% were married, 9.1% divorced, and 49.0% never married. Approximately 79.8 % of the nurses were in their 1<sup>st</sup> job with the remaining changing employers at least once. 85% worked full time, and 27.6% working in a magnet hospital. Newly licensed nurses were working a mean of 39.7 hours per week with a Standard Deviation of 8.31 hours. In the last reported work week, nurses cared for 8.85 patients with a Standard Deviation of 17.10. 73.9% of nurses worked a 12-hour shift. In general, new nurses rated their health as good to excellent: Poor (0.3 %), Fair (5.2 %), Good (27.6 %), Very good (43.3 %), Excellent (23.4 %), Missing Data (0.2 %). We would expect survivors and preppers to be healthy.

## RESULTS

Table 2 suggests that 10.7% of surveyed nurses would have an easy time finding a new job, whereas, 62.9% perceive would have a challenging to somewhat difficult time finding a new job. Nurses in this sample felt they have job mobility. It may be that there are few nursing jobs in the locale where the nurses wanted to work, or once hired, they realized they needed other skills to be mobile.

Table 2: Difficulty of Finding a New Job

Question	Very Difficult	Quite Difficult	Somewhat Difficult	Somewhat Easy	Quite Easy	Very Easy	Missing Data
Easy or difficult to find a job with another employer in the local job market: better than you have now	13.0%	17.0%	32.9%	20.6%	7.4%	3.3%	5.8%

Table 3 summarizes new nurses' desires to stay on the job or leave for another position. 18.5% of new nurses agree or strongly agree that they would like to leave their current employer. In contrast, 40% plan to stay as long as possible but, 19.4% express the desire never to leave their employer. For the most part, most nurses care about the fate of the employer (89.5%).

Table 3: Intent to Stay

Question	Strongly Disagree	Disagree	Neither Agree nor Disagree	Agree	Strongly Agree	Missing Data
Intent to stay with current employer: like to leave	28.6%	28.1%	19.6%	12.5%	6.0%	5.2%
Intent to stay with the current employer: plan to stay as long as possible	11.0%	18.7%	25.1%	24.5%	15.5%	5.2%
Intent to stay with my current employer: under no circumstances, I will leave my present employer	23.8%	25.6%	26.0%	11.9%	7.5%	5.2%
The situation in current job: Physician and nurses have a good working relationship	1.2%	7.3%	0%	63.1%	18.9%	9.5%
The situation in current job: Collaboration (joint practice) between nurses and physicians	2.2%	14.5%	0%	55.5%	18.0%	9.7%
I don't care about the fate of the employer	50.3%	29.1%	10.2%	3.8%	1.1%	5.6%

Table 4 suggests that approximately 39.5% of new nurses wish to complete their Undergrad Degree, and 33.6% want to go on to complete their master's degree in nursing. We would expect "Preppers" and "Survivors" to seek more knowledge and expertise. Not all nurses are preppers or survivors. Most new nurses reported that financial support was available for more schooling. So money is not an obstacle to gain more knowledge and expertise. Differentiating which nurses want advanced degrees might be a clue as to how to identify Survivors and preppers to management.

Table 4: Future Education Desired

If you continue education, Degree pursued	0 Not Circled	1 Circled	Missing Data

Baccalaureate degree in nursing	39.5%	38.3%	22.2%
Master's Degree in nursing	33.6%	44.2%	22.2%
Other	73.7%	4.6%	21.7%

In evaluating why 186 new nurses left their first job, there were several surprises. Nurses did not leave because of poor health or being fired. They did not go in overwhelming numbers for job-related issues such as stress, poor health. They left for some obvious reasons like being fired or reduced pay. More importantly, they left because of poor management, needed experience in another clinical area, quality work was not possible and lacked mentor support. Preppers would not like working for poor management as it would threaten their survival. They would be looking for mentors to learn how to survive and ways to broaden their knowledge base. A prepper who felt they could not do quality work would also leave because turning in bad work would threaten their survival as well. The lack of an opportunity to learn new skills would also be a warning flag to preppers.

Table 5: Why New Nurses Left Their First Job

Reason for Leaving 1 <sup>st</sup> job?	0 Not Circled	1 Circled
<b>Poor health/disability</b>	185	1
Partner has a job in another community	181	5
<b>Laid off or fired</b>	181	5
Need compatible schools schedule	179	7
Workplace constraints	172	14
No chance to make decisions about job	167	19
Misinformed about my job	166	20
<b>Not fairly rewarded</b>	166	20
Job lacked variety	164	22
Other professional reasons	163	23
Poor MD/RN relationship	162	24
Moved	161	25
<b>Stressful work</b>	125	61
<b>Poor pay</b>	149	37
Lacked peer support	149	37
Need flexible hours	144	42
No opportunity to learn new skills	143	43
Poor Orientation	140	46
<b>Lacked mentor support</b>	138	48
No opportunity to get ahead	138	48
<b>Quality work not possible</b>	135	51
<b>Experience in another clinical area</b>	114	72
<b>Poor Management</b>	112	74
Other personal reasons	96	90

## LIMITATIONS

The ICPSR data set of New Nurses is limited to only new nurses. This dataset does not allow for the identification of other variables or identities of older employees who might be preppers or survivors. There is not a direct correlation between attitudes, values, and beliefs of preppers, survivors, and nurses (healthcare workers). The ICPSR did provide insight into how to identify preppers and survivors based on exit information from their first job. The survey questions that asked new nurses about their willingness to leave a job found that there was a 10.8% group of nurses prepared who left their job but had already lined up a new job.

Furthermore, nurses were more concerned about proper mentoring and having experiences in other parts of the organization. This research was unable to pinpoint which nurses might be preppers, but it did provide some way to eliminate nurses who did not exhibit prepper characteristics. Preppers who are nurses fit the profile of wanting to learn and gain new experiences. They had a thirst for knowledge and a sense of self-sufficiency. We had no way of measuring their sense of compassion or the degree to which they upheld family values. Most nurses rated themselves as physically and mentally fit. Very few of the nurses said they left their first job because of stress. There was some indication that nursing preppers were networks, as well. Being able to leave one job and have another ready indicates the ability to network for that next job.

## CONCLUSION

Preppers are about gaining knowledge, being self-reliant, being physically fit, developing the mindset needed to survive some catastrophic event. Healthcare workers, nurses, in particular, worry about losing their job to a lack of competency or making some mistake that results in legal action, or the organization they are in, fail in some way. We thought nurses would prepare for all three eventualities. We found evidence that some nurses chose not to want to improve their competency. They were content with their educational level. These nurses were not worried about malpractice; they were not concerned with losing their job or worried that their organization might fail in some significant way. They were content with the status quo, unlikely to rock the boat, and perhaps were willing to be told what to do each step of the way. It was the thirst for knowledge that seemed to make survivors stand out.

Nurses who survive indicated a strong desire not to leave their first organization. They have a thirst for learning and a desire to develop additional competencies. We have no idea the skills they thought or if this group might desire more advanced Master's Degrees. The survey provided no information about their job or a description of their assigned duties. The number of new nurses who participated in outside activities or volunteered for outdoor activities was small. Being new to their job, lack of professional experience, or new to the community may explain a lack of leadership opportunities.

Preppers exist in the nursing community. We believe that additional research is needed to explore the possibility of different kinds of preppers depending on their motivation. Preppers may be job hopping to gain new experiences and training or changing jobs because of the lack of new opportunities in their current organization. Nurses may have left because they perceived

their organization in some tangible way and were moving on before down-sizing or some other catastrophic event occurred. There was no direct connection between nurse preppers and survivors. Future research should look at preppers only and evaluate the possibility of different kinds of preppers who express different traits but still maintain an identity as a prepper.

## REFERENCES

- [1] Ääri, R.-L., Tarja, S., and Helena, L.-K. (2008). "Competence in Intensive and Critical Care Nursing: A Literature Review," *Intensive & Critical Care Nursing* 24 (2), pp. 78-89.
- [2] Acker, A., and Carter, D. (2018). "Pocket Preppers: Performing Preparedness with Everyday Carry Costs on Instagram," *Proceedings of the International Conference on Social Media & Society*, Copenhagen: Association for Computing Machinery, pp. 207-210.
- [3] American Hospital Association. (2019). Fast facts on US hospitals, 2019.
- [4] Analysis, N. C. f. H. W., (2017). "The Future of the Nursing Workforce: National- and State-Level Projections, 2012-2025," U.S. Department of Health and Human Services, pp. 1-17.
- [5] Bae, S. H., Mark, B., & Fried, B. (2010). Impact of nursing unit turnover on patient outcomes in hospitals. *Journal of Nursing Scholarship*, 42(1), 40-49.
- [6] Bagley, C., Abubaker, M., and Sawyerr, A. (2018). "Personality, Work-Life Balance, Hardiness, and Vocation: A Typology of Nurses and Nursing Values in a Special Sample of English Hospital Nurses," *Administrative Sciences* 8 (4).
- [7] Britton, C. (2014). "10 Survivor Traits Every Prepper Should Have."
- [8] College, V. (2017). "15 Must-Have Traits of Future Nursing Assistants."
- [9] Duff, E. (2019). "A Structural Equation Model of Empowerment Factors Affecting Nurse Practitioners Competence," *Nurse Education in Practice* 38 (1), pp. 145-152.
- [10] Fetterman, A. K., Rutjens, B. T., Landkammer, F., and Wilkowski, B. M., (2019). "On Post-Apocalyptic and Domsday Prepping Beliefs: A New " *European Journal of Personality* (33), pp. 506-529.
- [11] Foundation, R. W. (2014). "Nearly One in Five New Nurses Leaves First Job within a Year, According to Survey of Newly-Licensed Registered Nurses." Robert Wood Foundation.
- [12] Froutan, R., Mazlom, R., Malekzadeh, J., and Mirhaghi, A. (2018). "Relationship between Resilience and Personality Traits in Paramedics," *International Journal of Emergency Services* 7 (1), pp. 4-12.
- [13] Kearney, J. (2019). "The Top 10 Personality Traits of a Prepper."
- [14] Kovner, C., and Brewer, C. (2018). "Newly Licensed Registered Nurse New Cohort 3 Survey, 2016." Inter-university Consortium for Political and Social Research.
- [15] Levy, G., (2019). "The 10 Personality Traits of Successful Survivalists." *Backdoor Survival*
- [16] Matos, P. S., Neushotz, L. A., Griffin, M. T. Q., and Fitzpatrick, J. J., 2010. "An Exploratory Study of Resilience and Job Satisfaction among Psychiatric Nurses Working in Inpatient Units," *International Journal of Mental Health Nursing* 19 (1), pp. 307-312.
- [17] Plenaar, J. W., and Bester, C. L. (2011). "The Impact of Burnout on the Intention to Quit among Professional Nurses in the Free State Egion - a National Crisis?," *Psychological Journal of South Africa* 41 (1), pp. 113-122.
- [18] Richardson, R. (2012). "4 Powerful Traits of Survivors." *OffGrid Survival*, 2019
- [19] Rosenbaum, M., (2018). "Will 2018 Be the Year Healthcare Addresses Its Turnover Problem?" in *Becker's Hospital Review*. Hospital CFO Report: ASC COMMUNICATIONS.
- [20] Siebert, A. (1996). "The Survivor Personality," in *The Survivor Personality*. Berkley/Perigee Books.
- [21] Siebert, L. A. (1977). "The Self Determination of Success," in *Nation's Business*. Washington: Chamber of Commerce of the United States, p. 42.

- [22] Sims, A., and Grigsby, M., (2019). "Prepper-Worthy Identity Work: A Cultural Repertoire for Constructing a Secure Self in an Unsecure World," *Sociological Spectrum* 39 (2), pp. 93-115.
- [23] Solutions, N. N. (2015). 2015 national healthcare retention & RN staffing report.
- [24] Washburn, R. (2018). "The Top 10 Qualities & Characteristics Every Nurse Should Have, Soliant (ed.).

## **ONLINE HEALTH COMMUNITIES: THE IMPACT OF SOCIAL SUPPORT ON THE HEALTH STATE OF PEOPLE WITH CHRONIC ILLNESS**

Zachary Davis, Davis College of Business, Jacksonville University, 2800 University Blvd N, Jacksonville, FL 32211, 434-414-5160, [zdavis1@ju.edu](mailto:zdavis1@ju.edu)

### **ABSTRACT**

People with a chronic illness require daily medical care over the course of their lifetime and with this comes an emotional burden that is difficult to share with people not managing the same illness. Finding others with the same illness to discuss questions and concerns with used to be quite difficult but with the rise of online health communities connecting with others has become significantly easier. We examine an online health community used by people with diabetes to determine the effect of social support, in the form of informational support, emotional support, and companionship, on their overall health.

### **INTRODUCTION**

For patients with chronic illnesses their healthcare provider alone may not fulfill the need for social support. As a result of this need, patients seek support elsewhere, often through online health communities. An online health community can provide users with a virtual social support system made up of others with similar health issues and thus similar concerns. One concern that health care providers have regarding patient use of online health communities is the validity of the advice users receive regarding their health. Those providing advice in online health communities are likely other laypeople with the same illness, however they could be anyone ranging from another healthcare provider to just someone hoping to have influence over others.

Use of online health communities by people with chronic illness has been examined in other studies [7] [9]. Van der Eijk et al. [7] examined an online health community of people with Parkinson's, their families and healthcare professionals and examined how this platform could be utilized to improve health in those patients. Yan and Tan [9] proposed and examined a model for measuring the impact that participation in an online health community has on the user's health. Social support has been found to be impactful on improving the health state but the examination of active participation in the online health community as well as how these aspects continue to affect each other with continued use has not yet been measured.

Thus far, research regarding online health community use has largely been subjective, utilizing surveys in which the users of online health communities are asked if the online support they receive is impactful to their health or to their healthcare management [5] [8] [10]. Although these subjective measures provide information regarding the impact an online health community has on the health condition, the ability to identify an objective improvement in the health state would be more definitive in determining the impact the online health community has on the health state. Therefore, to discover the impact an online health community has on a user's health condition we utilize laboratory values that provide a demonstration of the user's health condition and examine changes over time. We also examine informational support given and received,



emotional support given and received, and companionship, culminating in the social support given and received and thus, their impact on the health state. Our model aims to quantify the impact that participation and social support have on the health condition and characterize how each of these aspects impact the others.

### **LITERATURE REVIEW**

Several areas of previous literature contribute to our research focus. Many studies have identified that participation in an online community allows participants to take on formal or informal leadership roles [2] [4] [6]. Faraj et al. [2] also found that knowledge collaboration occurs across online communities. Those who participate in online health communities have been identified as patients who take a more active role in their healthcare [7], which may also mean that they are good sources of knowledge for those who may be newly diagnosed, or for those seeking to be more active in their care or seeking to learn from others. An online health community also offers a social platform as opposed to the official means of communication offered by medical professionals, and social support has been shown to have a great impact on the health condition [3]. Prior research has shown a link between participation in an online health community and an impact on the health condition; however, such studies have not utilized a fully objective measure of the health condition [1] [9]. This exposes a gap in the research in regard to interactions between participation in an online health community, the giving and receiving of social support in that community, and an improvement in the actual health condition. We thus aim to extend the work of Yan and Tan [9] by examining a fully objective measure of the health condition.

### **MODELING FRAMEWORK**

As we seek to examine the impact social support received in an online health community has on the users' health condition, we created a model to depict our research structure (see figure 1).

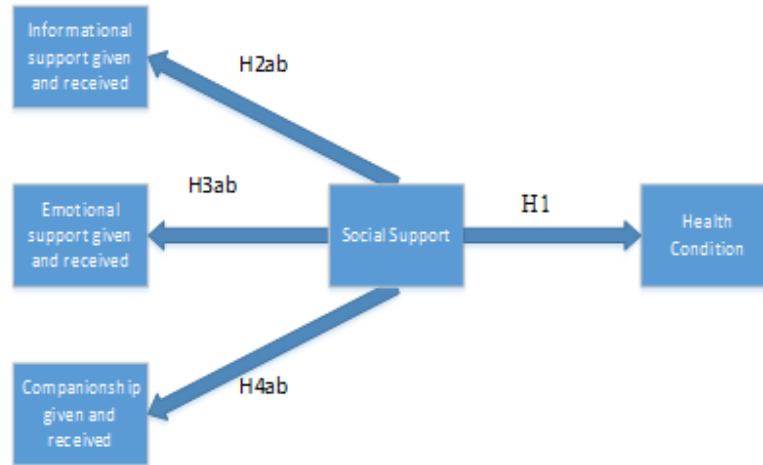
**FIGURE 1 MODEL**

Following the model creation, we devise the following hypothesis:

*Hypothesis 1: Social support given and received in an online health community positively impacts a change in the user's health condition.*

*Hypothesis 2: Informational support given and received in an online health community positively impacts the social support of the online health community.*

*Hypothesis 3: Emotional support given and received in an online health community positively impacts the social support of the online health community.*

*Hypothesis 4: Companionship given and received in an online health community positively impacts the social support of the online health community.*

By examining the various aspects identified as social support and matching it to participants in the online health community, we then examine the health condition and compare these values to determine the change in the health condition, whether positive, negative, or neutral and the extent to which the social support was impactful.

## METHODOLOGY

In this paper we conduct our research on the online health community, <http://www.diabeticconnect.com/>, which allows for the interaction of users allowing them to share information about the medical devices they use, diet plans, laboratory values and medications as well as offer social support to one another. To obtain the data we utilized a web crawling script that collected all fields and post data from every user in the online health community and extracted these data values to an excel CSV file. To analyze the model, we use RStudio Version 0.99.896 and structural equation modelling package SEM. We utilized a reflective causal structure whereby the latent variables of social support and health condition

flow to the indicator variables. The relationship between the indicator variables and latent variables are presented in table 1.

**TABLE 1 INDICATOR VARIABLES**

<b>Indicator Variable</b>	<b>Latent Variable</b>	<b>Description</b>
Emotional Support Received	Social Support	The emotional support the user has received
Emotional Support Given	Social Support	The emotional support the user has given
Informational Support Received	Social Support	The informational support the user has received
Informational Support Given	Social Support	The informational support the user has given
Companionship Received	Social Support	The companionship the user has Received
Companionship Given	Social Support	The companionship the user has Given
Healthy	Health Condition	Binary variable: 1=healthy value,0=unhealthy value
Lab Value	Health Condition	The last lab value the user posted
delta Lab value	Health Condition	The change in overall lab values of the user since using the online community

## **RESULTS**

The results of the structural equation model analysis are presented in table 2.

**TABLE 2 SEM RESULTS**

Hypothesis	Path	Estimate	Std Error	Z Value	Pr(> z )
1	Social Support -> Health Condition	-0.088	0.051	-1.722	0.085
	Health Condition -> Lab Value	1.663	0.107	15.583	<0.001
	Health Condition -> delta Lab Value	1.337	0.177	7.537	<0.001
	Health Condition -> Healthy	-0.343	0.029	11.744	<0.001
2a	Social Support -> Informational Support Received	35.751	1.553	23.014	<0.001
2b	Social Support -> Informational Support Given	8.706	1.057	8.240	<0.001
3a	Social Support -> Emotional Support Received	20.075	0.911	22.034	<0.001
3b	Social Support -> Emotional Support Given	4.232	0.496	8.538	<0.001
4a	Social Support -> Companionship Received	22.106	0.878	25.169	<0.001
4b	Social Support -> Companionship Given	6.392	0.778	8.24	<0.001

We can see from table 2 that each of the paths of the indicator variables yields very significant results. The most interesting path we observed exists between the latent variables Social Support and Health Condition. We can see that at the 90% confidence level the users' health condition improves by about 0.08 with participation in the online health community.

### IMPLICATIONS

Our study has many managerial implications for online health community providers, healthcare professionals, and patients with a chronic illness. First, providers can develop mechanisms to encourage social support behaviors, which lead to an improvement in the health condition for people managing a chronic illness. Second, our findings inform health professionals about the importance of community support and the relevance of receiving this support through participation in an online health community. Lastly, patients may respond differently to the support they receive in an online health community. Our research allows healthcare professionals to provide better education for patients so that they can respond to social support in a positive manner.

### REFERENCES

- [1] Cline, R. J., & Haynes, K. M. Consumer health information seeking on the Internet: The state of the art, 671-692. *Health Education Research*, 2001, 16(6).
- [2] Faraj, S., Kudaravalli, S., & Wasko, M. Leading collaboration in online communities, 393-412. *MIS Quarterly*, 2015, 39(2).
- [3] Goh, J. M., Gao, G. G., & Agarwal, R. The creation of social value: Can an online health community reduce rural-urban health disparities?, 247-263. *MIS Quarterly*, 2016, 40(1).

- [4] Johnson, S. L., Safadi, H., & Faraj, S. The emergence of online community leadership, 165-187. *Information Systems Research*, 2015, 26(1).
- [5] Johnston, A. C., Worrell, J. L., Di Gangi, P. M., & Wasko, M. Online health communities: an assessment of the influence of participation on patient empowerment outcomes, 213-235. *Information Technology and People*, 2013, 26(2).
- [6] Oh, W., Moon, J. Y., Hahn, J., & Kim, T. Research Note—Leader Influence on Sustained Participation in Online Collaborative Work Communities: A Simulation-Based Approach, 383-402. *Information Systems Research*, 2016, 27(2).
- [7] van der Eijk, M., Faber, M. J., Aarts, J. W., Kremer, J. A., Munneke, M., & Bloem, B. R. (2013). Using online health communities to deliver patient-centered care to people with chronic conditions, e115. *Journal of Medical Internet Research*, 2013, 15(6).
- [8] Welbourne, J. L., Blanchard, A. L., & Wadsworth, M. B. Motivations in virtual health communities and their relationship to community, connectedness and stress, 129-139. *Computers in Human Behavior*, 2013, 29(1).
- [9] Yan, L., & Tan, Y. Feeling blue? Go online: an empirical study of social support among patients, 690-709. *Information Systems Research*, 2014, 25(4).
- [10] Zhao, K., Yen, J., Greer, G., Qiu, B., Mitra, P., & Portier, K. Finding influential users of online health communities: a new metric based on sentiment influence, e212-e218. *Journal of the American Medical Informatics Association*, 2014, 21(e2).

### **Simulation Analysis of an Obstetrical Emergency Department Unit**

Dr. C.David Adair - Erlanger Health Systems, Chattanooga, TN 37410

Dr. Mohammad Ahmadi - Gary W. Rollins College of Business, The University of Tennessee  
Chattanooga, Chattanooga, TN 37403

Dr. PARTHASARATI DILEEPAN - Gary W. Rollins College of Business, The University of  
Tennessee Chattanooga, Chattanooga, TN 37403

#### **Abstract**

High acuity areas, such as emergency rooms, follow simple supply and demand curves. They have high resource value but limited availability, thus an imbalance occurs creating a high demand state. This limited availability can be maximized by simulation modeling to ascertain and identify potential obstacles to efficient resource utilization. Specialty specific emergency departments are a recent concept, which have evolved over the past two decades. Like its larger counterpart, these units can be fraught with overcrowding, which can impact care delivery. There have been several efforts to provide simulation analysis in the macrocosm of the Emergency department and other specialty units, to our knowledge none have been done to specifically examine this microcosm of an Obstetrical Emergency Department. In this paper we present such an analysis. We show that an obstetrical specialty specific emergency department has several “bottleneck” areas. These constraints project poorly to the patient and serve for frustration to care providers. By identifying and better managing these impediments, improved outcomes, better morale, and satisfaction by all can be expected. Specifically patient wait times can be minimized and quality perception improved.

## INTRODUCTION

Hospital emergency departments are a high acuity, stressful environment that serve as the gateway to a hospital. A central tenet of emergency room care provision is that a patient with an acute medical condition will be diagnosed, provided appropriate level of care, have their condition cured or improved with said treatment, and ultimately deliver an overall excellent patient (consumer) experience. While these are the stated goals, all too often the process is flawed by overcrowding and long wait times. These system processes are perverse to the central tenet; the overcrowding and delays lead to increased adverse patient outcomes and poor Hospital Consumer Assessment of Healthcare Providers and Systems (HCAHPS) [8]. HCAHPS is the consumer scoring system that is used to monetarily incentivize quality and ratings by the Center for Medicare and Medicaid Services (CMS). In theory this is used to reward high performing units and alternatively to punish poor care provision providers. Several healthcare systems have utilized business techniques, specifically simulation analysis to improve on healthcare delivery and the provision of care to meet the central patient tenet [24][23][33][10][9][18][34].

Currently, there are close to 4 million births in the United States annually, of which the vast majority present to a healthcare facility for obstetrical delivery [6]. Data would suggest that about another 50 to 70% of that delivery volume presents to healthcare systems for evaluation of ailments prior to the actual admission for childbirth [22]. If a non-pregnant patient presents to any hospital and registers a medical complaint, the patient is evaluated by a licensed healthcare provider assuming she does not leave without being seen. This is often due to dissatisfaction of wait time and perceived lack of quality [27][19][31][21][5][8]. The federal Emergency Medical Treatment and Labor Act (EMTALA) requires all patients to be evaluated by a medical appropriate provider prior to discharge or transfer from a healthcare facility [7]. In the emergency room, this is always facilitated by a licensed medical provider, unlike its counterpart service line, the obstetrics ward, which has most patients evaluated by a registered nurse followed by consultation with a provider, often via telephonic means, and then enactment of a clinical decision. This system is fraught with delay and potential error sources. The common approach relies on critical data gathering and analysis that is conveyed for crucial decision making. Often times this routine is carried out by the least qualified personnel. This in turn can lead to long wait times and inconsistent health care delivery. More importantly, it can have

devastating consequences with serious injury or death to either one or both patients, the fetal maternal dyad. Prior studies have shown patient dissatisfaction rates correlate with the patient perception of quality, as they have a high rate of representation within 24 hours of prior evaluation when quality was perceived as poor [32][11][28][29]. This re-presentation for clinical care is a vote of dissatisfaction expressed by patient action, these are largely for the original complaint or symptom(s). This pool of “re-presenters” causes further delays, which in turn adversely impacts the health care delivery and increases costs [20] [14].

The Erlanger Health System of Chattanooga, Tennessee accounts for almost 5,600 deliveries annually. Hamilton County, where our system is located accounts for almost 7,800 deliveries annually. Our hospital is a level 4 maternity and Neonatal hospital. We serve as the dedicated regional perinatal referral system for a 50,000 square mile area, encompassing eastern Tennessee, northwest Georgia, western North Carolina, and northeast Alabama. We also house an obstetrical and gynecology residency program, with 16 residents, as part of the University of Tennessee College of Medicine. The hospital has an obstetrical payor mix of 30% commercial, 65.8% federal funded and 4.2% self-pay.

Our hospital campus previously relied on such an antiquated approach of evaluating the pregnant patient with medical complaints besides labor. The Baroness Campus in 2013 undertook an analysis on an innovative approach to address this discrepancy in provision of care to its maternity patients. Other similar sized systems had utilized a full time Medical Doctor to staff an Obstetrical Emergency Department. While that approach achieved improved wait times and outcomes, it is volume dependent and would need an excessively prohibitive number of visits to enhance financial robustness as a standalone unit. When coupled as a segment of an overall duty roster that staffs labor & delivery it becomes financially viable at a lower number. Despite which staffing model is pursued, physician versus advanced practice provider, an improved financial status results to the system due to the ability to bill an emergency room visit rather than eat into or take a piece of a global event of obstetrical care. The financial impact to a healthcare system is transformational as the prior non-provider results in reimbursement that is less than the cost of provision of care as payment. In a provider model there is both a significant positive impact on both contribution margins and net profits for the specialty unit [30]. The Baroness campus pursued a hybrid approach in which advanced practice providers were entrenched around



the clock, 365 days a year, with availability of an in-house 24-7-365 obstetrician gynecologist with back up consultation with maternal fetal medicine physicians 24 hours a day by on call provision. This approach has been reported previously with noted optimization in patient flow, improved efficiency reduced patient times, and significant reductions in medical legal exposure risks [35][3][26]. This initiative commenced in August of 2014 as a 21-hour staffing model, then converted to a 24-hour fully staffed unit in July 2015. While the emergency department, operating room scheduling, and even pediatric service lines are well researched with lean process improvements and simulation analysis from prior efforts of others, the relatively new concept of an OB ED has less well-established efforts [24][23][33][10][9][18][34][2][3][4][26]. It is this program that we herein report on a simulation analysis of our unique single specialty unit.

### **LITERATURE REVIEW**

The emergency departments of most hospitals around the United States are overcrowded. They are clogged down with patients who use the department as their primary care physician and other non-emergency situations. Hospitals are challenged financially every day. Reimbursement, HCAHPS, and billing all need to be managed to ensure their viability. The OB Emergency Department is a new concept that takes on the challenge of its much larger counterpart to try to improve the system. Although there has not been much research on the OB Emergency Department, we did find a number of studies on the Emergency Department as a whole. In the article, "Emergency department overcrowding in the United States: an emerging threat to patient safety and public health", Trzeciak and Rivers discuss the problem. Trzeciak and Rivers state that although no precise definition exists, ED overcrowding refers to an extreme excess of patients in the treatment areas, exceeding ED capacity and frequently necessitating medical care to be provided in ED hallways and other makeshift examination areas. They discuss five manifestations of ED overcrowding including, boarding patients in the ED, increased risk of medical errors, ambulance diversion, threat to disaster preparedness, and eroding of the emergency care system. The solutions Trzeciak and Rivers propose are to safeguard the ED "safety net", provide an alternate location for patients to go such as observation units, develop early warning systems, utilize strategic planning, and utilize a multidisciplinary approach. The OB ED takes into account many of these recommendations. Erlanger utilizes a multidisciplinary approach that takes OB patients out of the main emergency department and places them on an

alternate floor of the hospital with dedicated OB staff. The team at Erlanger has also deployed early warning systems by communicating with the EROC (Erlanger Regional Operations Center) on where OB patients should be taken within the hospital.

The OB ED concept was greatly advanced and chronicled over the past 2 decades by Angelini and coworkers. The initial effort was in 1990 in which the realization of defined provider roles and schemes for obstetrical triage were originally proposed in the *Journal of Perinatal Neonatal Nurses*. The consideration of “birthing” an obstetrical triage unit, a forerunner to the current OB ED was brought forth from this effort.

Angelini in a solo effort reported in the *Journal of Nurse Midwifery* in 1999, the concept of using nurse midwives as the providers for obstetrical triage services. She undertook a national survey to determine how common was the practice, implementation and to what extent nurse midwives played in assessing and triaging obstetrical patients. While obstetrical complaints are common on a labor and delivery deck, the effort also sought to determine the role of these advanced providers on non-obstetrical complaints that presented for evaluation. This paper served as the backbone for the development of our Baroness Erlanger program, which we implemented some 15 years after this effort.

This same investigative group followed this effort in 2005, in the *Journal of Midwifery Women’s Health* [4], with a treatise on the liability of the “traditional” obstetrical triage model that was being utilized around the country. The effort focused on proper interpretation, implementation, and management of EMTALA regulations in the obstetrical triage arena. Through this effort it called attention to the glaring discrepancy in healthcare delivery to the pregnant patient, highlighted the liability exposure healthcare systems incurred, knowingly or unknowingly, and was a call to arms for improvement in obstetrical triage care. Four common tenets were required to meet compliance. First, an individual (determined, qualified, or designated by the hospital), notice no predetermination of educational background qualifications, would perform a medical screening visit to determine if an emergency medical condition was present. This should also include evaluation of the fetal compartment. Secondly, if an emergent condition was determined to be present the individual should be stabilized for care at the evaluating facility or stabilized for a transport to a higher facility of care. Third, evaluate a risk benefit analysis of transport versus

retaining the patient at current facility. Once determined that a higher level of care is needed, and the patient is stabilized for maximized outcome, the initiating facility should coordinate with a receiving facility with the appropriate level of care and ensure that the transport teams are appropriately equipped and trained. Lastly, medical screening is not to be delayed due to payment ability, insurance status, or financial arrangement making.

In the article “Emergency department ‘under crowding’ is associated with decreased waiting times” [1], discuss the problem of ED overcrowding. Defining the problem as impeded ED function due to the number of patients waiting to be seen, undergoing assessment, receiving treatment, waiting to leave exceeding the physical, or staffing capacity of the ED. Describing overcrowding as the single greatest impediment to the provision of safe and efficient emergency care [1], cite long wait times, which they claim, lead to a decrease in both patient quality of care and satisfaction. Overcrowding can also cause delayed treatment as well as cause patients to seek medical attention elsewhere. These outcomes can directly impact a hospital’s income. In this same study, the authors analyzed the impact of opening an additional freestanding emergency department. Like our hypothesis on opening an additional ED in the form of the OB ED the authors found that by opening a freestanding ED they improved the problem defined above. Specifically, they found that controlling demand can significantly benefit the patient flow and drop the wait time.

In a 2015 Canadian effort by Schull et al, this group investigated ED crowding and its impact on adverse patient outcomes. The investigators examined retrospectively, the length of stay in the ED to adverse outcomes in Ontario, Canada over a 4-year period. Death with 7 days or hospitalization were the defined adverse outcomes after the initial ED evaluation. This group found an increase for these poor outcomes were highest during times when established benchmarks for Canadian ED care were not met.

George & Roussel performed a literature review in 2015 [16], specifically on ED crowding. They analyzed over 30 papers for their analysis, which included only papers from the 21<sup>st</sup> century. This synopsis also found higher rates of delay in treatment/interventions, observed higher rates of medical errors and adverse patient outcomes, and most importantly increased patient mortality.

The article, “Improving the performance of surgery-based clinical pathways: a simulation-optimization approach” [25], discuss improving the performance of clinical processes using clinical pathways. They utilized a simulation optimization model that seeks and evaluates alternative resource configurations aimed at balancing their two main objectives; meeting patient needs and optimal utilization of beds and operating rooms. This study uses the main performance measures of the surgery specialties reported in the previous section: number of surgical patients (throughput); operating room (OR) utilization rate; and bed utilization rate. The resource variables driving this optimization model include the following: (1) number of beds; (2) number of OR block times; and (3) duration of each block. The solutions include adding various combinations of Operating Room block time and inpatient beds. The first strategy adds only additional OR block time. The second strategy adds an additional inpatient bed as well as OR block time. The third and final strategy adds three additional OR blocks and one inpatient bed. The OB ED improves clinical pathways by dedicating both high risk as well as regular inpatient beds in the unit for the OB ED use. We also have dedicated block time in the OR for patients that need to be taken to surgery.

In LeAnn Hardin’s poster presentation titled, “Transforming Obstetric Triage into an Obstetric Emergency Room” [17], she discusses the major benefits of implementing an OB ED. Primarily by educating women in the outpatient setting as well implementing a new hospital wide policy fewer women were seen in the main emergency department. The hospital saw revenue increase by \$365,000 per quarter after the implementation and increased patient satisfaction, which directly impacts HCAHPS scores and reimbursement.

In the Emergency Medicine Journal article [13], “Entry overload, emergency department overcrowding, and ambulance bypass” authors D.M. Fatovich and R.L. Hirsch discuss the various causes and effects of overcrowding in the emergency department. They focus on a previously undiscussed topic of blocks; access and entry blocks. Access block in their definition refers to the situation where patients in the ED requiring an inpatient bed are unable to access the appropriate hospital bed within a reasonable time frame. They define entry block as entry into the ED being blocked due to an overwhelming number of patients attending the ED in a short space of time. “Entry block” can significantly impair access to emergency care by forcing

ambulances to bypass the hospital and take patients to a facility with a lower level of care. The article suggests stop gap measures of ambulance diversion, increasing ED capacity with both human and physical resources, reopening inpatient beds, postponing elective surgery, and improving discharge processes. By implementing an OB dedicated ED Erlanger can avoid ambulance diversion. The OB ED also increases the ED capacity by having a dedicated space for obstetric patients in need of emergency care. Finally, the OB ED improves the discharge process by having dedicated staff to evaluate emergency obstetrics patients thus having fewer misdiagnosis as well as clear clinical/patient communication.

### **MATERIALS & METHODS**

We chose to analyze the dates of July 1, 2015 to June 30, 2017. This period was the first two complete fiscal years for our OB ED unit, at the Baroness Erlanger Hospital in Chattanooga, TN. The data base represented over 10,000 individual visits to our facility. Since visit specific information was determined to be important, each individual could be represented by multiple visits, but each unique visit was analyzed rather than specific individual patient. We determined background demographics that included age, source of transportation, level of emergency acuity status, and final disposition. We specifically analyzed total time represented from registration to disposition, with each care point analysis inclusive of the following: time to registration, time to triage, time to nurse, time to advanced practice provider, time to resident consult, time to attending physician, and time to final disposition (Figure 1). We layered status of disposition to explore for interactions for prolonged total times, i.e., does an admission take longer than a home discharge. This exploration of this analysis would account identification of potential “choke points” in our system flow.

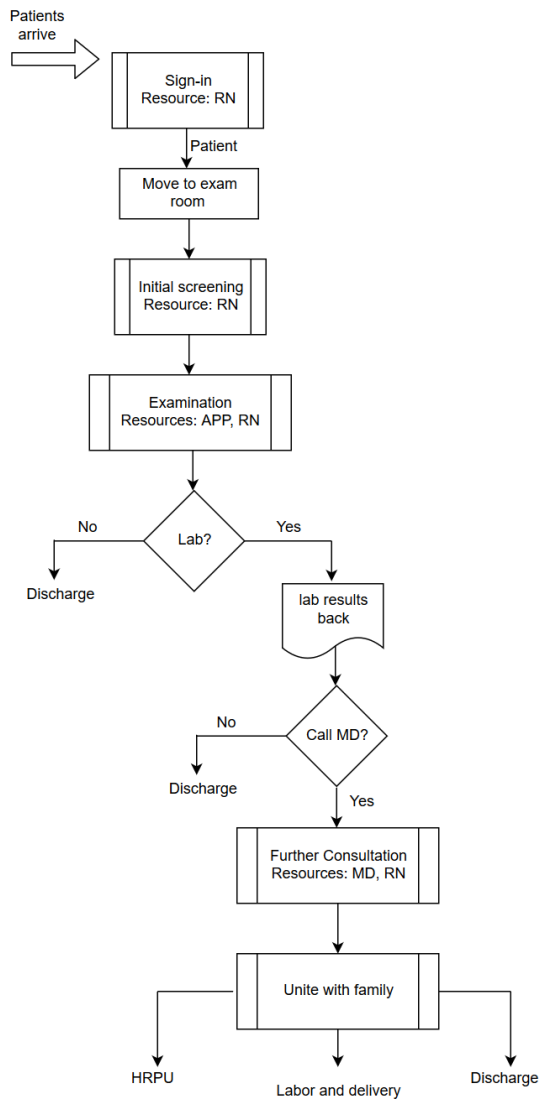

**Figure 1: Legend:**  
 RN: Registered Nurse  
 APP: Advanced Practice Provider  
 MD: OB/GYN Physician  
 HRP: High Risk Pregnancy Unit

**Figure 1 – Patient Flow Pattern**

Key inputs for construction of a query-based model were outlined by representatives of each key stakeholder. These included an emergency department physician, maternal fetal medicine specialists, nursing and clinical service line administrators, OB ED advanced practice providers, resident physicians, and nursing staff. We used an illustrative computer simulated model to simulate our patient care path for presentation to the obstetrical emergency department. We purposefully choose acuity level, means of arrival (self-driven), ground or air ambulance, and time from initial presentation to transfer from our specialty unit to either home, Labor &

Delivery, or our high risk pregnancy unit (HRPU). Our key outcomes were patient care wait times based upon our modeling analysis.

Our unit is housed within an approximate 5000 square foot floor plan. The OB ED unit is subdivided into four individual exam rooms of about 750 square feet each, one central common bathroom measuring 750 square feet, and a common provider area of about 1500 square feet. The common area houses all electronic medical records, in suite ultrasound, low acuity lab testing that includes microscopy for evaluation of membrane rupture, vaginal spotting/discharges, and other common obstetrical complaints. The unit is connected to the hospital main frame and has full access to all radiographic, laboratory, and ancillary services available throughout the hospital. The unit is staffed with one advanced practice provider, a unit specific nurse, and one patient care coordinator. Our unit has specialty signage, direct patient elevator access, and has both an emergency room and maternal-fetal medicine specialists as co-directors for medical quality oversight and protocol development.

### **RESULTS**

A total of 10,092 visits were observed during the defined study period of July 1, 2015 to June 30, 2017. The annual visit total period immediately prior to implementation of this hybrid model was 3400 visits in July 1, 2012 to June 30, 2013. The implementation of this specialty specific emergency department spurred additional visits not previously realized of over 5,000 visits annually. This represented a growth of women's service line business of roughly 50% in terms of visit volume on an annual basis. The area prior to implementation was noted to be a lost leader for our service line, it accounted in excess of 2 million dollars in losses annually. With this implementation of the novel hybrid system the unit had a reversal of losses and actually posted a net swing in contribution margins of revenues of over 2.5 million dollars for the study period annually, a 4-million-dollar swing in operating performance.

### **THE DATA AND PROCESS**

Patients' data were available from July 2015 when the Obstetrics Emergency Department (OBED) operations commenced until October 2017. During this period, 11,932 patients were admitted to the OBED and were treated. The summary of the patient arrival data by month and the hour of the day is given in Table 1 and plotted in Figure 2.

**Table 1: Average number of patient arrivals for the month and the hour of the day**

Hour	Jan	Feb	Mar	Apr	May	Jun	Jul	Aug	Sep	Oct	Nov	Dec
0	13.5	13.0	10.0	14.5	19.5	19.5	15.7	17.7	12.0	15.7	10.5	10.5
1	15.0	13.0	10.5	12.0	11.0	11.5	11.3	9.7	15.3	10.3	10.5	10.5
2	8.5	6.5	7.5	7.0	10.5	12.0	9.0	10.3	10.7	8.3	9.5	8.0
3	10.0	7.0	7.5	12.5	10.5	5.5	8.3	9.3	8.3	6.0	8.0	6.0
4	7.0	7.0	5.0	7.0	9.0	9.0	7.0	6.7	6.7	8.0	6.5	7.0
5	6.0	8.5	9.0	8.5	6.0	9.0	12.7	7.0	8.0	8.3	10.5	7.5
6	5.0	5.0	4.5	9.0	6.5	6.5	6.0	5.3	5.0	7.0	7.0	6.0
7	8.0	7.0	10.5	6.5	4.0	7.0	12.0	10.0	11.7	9.0	9.0	7.0
8	10.0	9.0	12.0	10.5	11.5	11.5	8.7	11.7	11.7	11.3	10.0	13.0
9	13.0	14.0	11.0	17.0	19.5	13.5	11.7	18.3	17.3	14.3	16.5	19.0
10	23.0	21.5	18.5	28.5	18.5	21.5	20.3	22.0	23.0	17.7	18.0	15.0
11	28.0	14.0	24.5	24.5	18.5	19.0	25.7	20.7	22.7	22.7	23.0	18.0
12	17.0	25.0	20.0	25.0	25.0	22.5	27.3	24.7	20.3	23.0	17.5	23.5
13	23.0	21.0	21.0	23.0	26.5	16.5	24.7	26.7	20.0	20.3	22.0	24.5
14	24.5	23.0	17.0	22.0	23.5	21.0	23.0	26.3	27.0	19.7	17.5	20.5
15	24.0	18.0	27.0	20.5	23.0	24.5	23.3	30.3	24.7	19.0	30.0	25.0
16	22.0	19.5	26.0	24.0	29.5	29.0	30.0	27.7	32.7	23.0	26.5	30.5
17	32.5	27.0	24.0	26.0	24.0	26.5	24.3	22.7	29.0	24.0	30.0	35.0
18	27.0	16.0	26.0	28.0	33.0	25.0	24.0	24.0	28.3	23.3	24.5	20.5
19	22.0	19.0	20.5	23.5	17.0	27.0	20.7	27.0	21.7	22.3	23.5	26.5
20	23.0	26.5	27.5	24.5	27.0	16.0	23.3	29.7	22.3	29.3	21.0	22.5
21	24.0	13.5	23.5	30.0	28.0	23.0	27.3	24.0	29.0	22.0	28.5	20.0
22	20.0	20.0	24.0	21.5	26.0	25.0	21.3	27.7	20.3	20.7	21.0	23.5
23	22.0	11.5	19.0	17.5	22.5	15.0	19.0	20.7	25.0	16.7	13.0	16.5



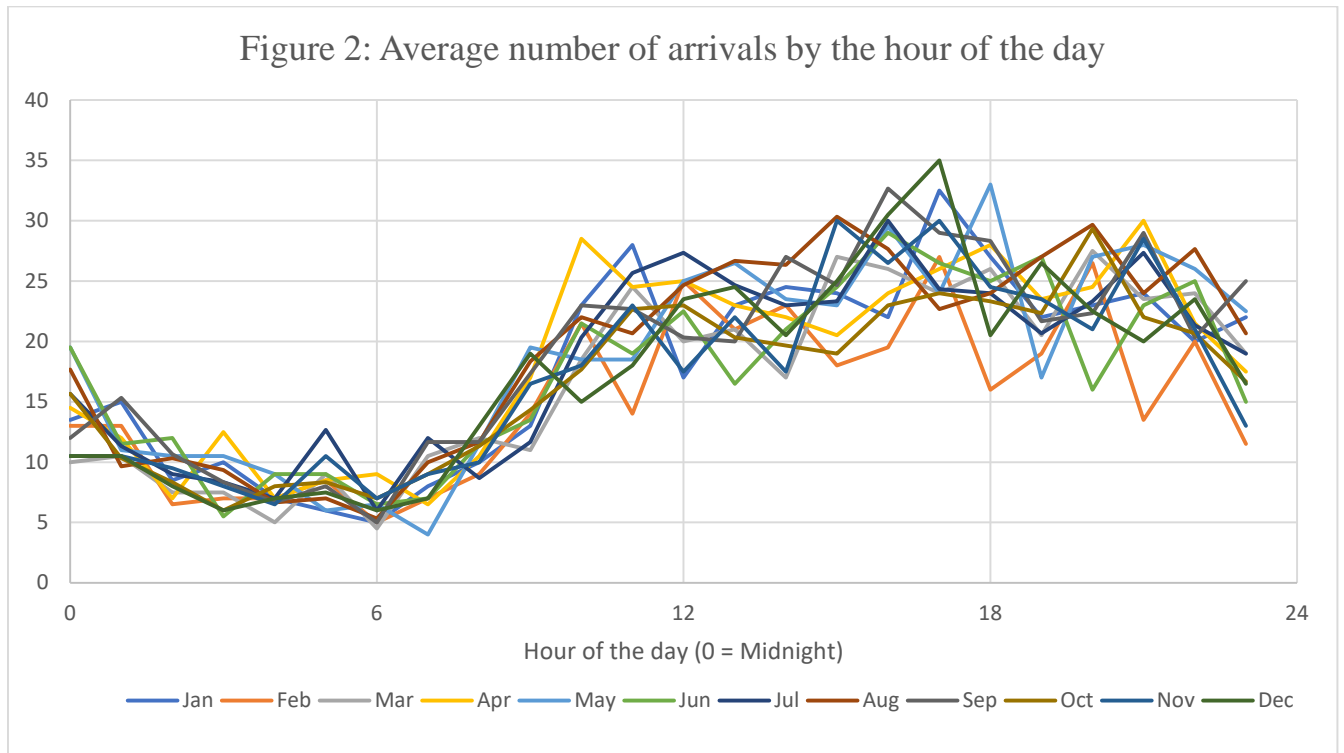

From Figure 2 the arrival rate of patients shows a consistent pattern that varies by the hour of the day. The plot also shows monthly pattern in patient arrival rate, albeit in a less clear way. To capture these patterns, the average time between arrivals for each hourly interval of the day for each of the twelve months was calculated and used with the exponential distribution to generate patient arrivals.

Arriving patients are triaged into one of the five levels of Emergency Severity Index (ESI) [12]. The probability distribution for the ESI level of arriving patients was developed from an analysis of the patient arrival data. This distribution, given in Table 2, was used to classify the arriving patients into the five ESI levels.

**Table 2: Patient Emergency Severity Index**

Patient ESI Level	%
ESI Level 1	0.1%
ESI Level 2	6.2%
ESI Level 3	66.3%
ESI Level 4	27.0%
ESI Level 5	0.4%

The OBED is staffed 24 hours of the day by one registered nurse (RN) and one Advanced Practice Provider (APP). The arriving patient is admitted in by the RN on duty and moved to one of the four examination rooms. The time required to complete this process is assumed to follow an exponential distribution with an average of 5 minutes. Once in the examination room, the RN performs the initial screening that includes history of present illness, medical history screening, and vital sign obtainment that includes blood pressure, pulse, respiration rate, pulse oximetry, temperature, and screening urine analysis. The time required is assumed to follow exponential distribution with an average of 10 minutes.

After the initial screening, the APP conducts the examination with the assistance of the RN. All ESI Level 1 patients, who are stable and requiring no further care at this point, are discharged. For all other patients, necessary samples are taken and sent to the lab for Basic Metabolic Profile (BMP), Complete Blood Count (CBC) and Urine Analysis tests. The average lab test turnaround times for the three tests are given in Table 3.

**Table 3: Average turnaround time for lab tests in minutes**

Test	Minutes
BNP	76
CBC	56
UA	64

After all the three lab test results are received a call is made to the Obstetrics MD on duty. The wait time for the MD to arrive follows an exponential distribution with an average of 10 minutes. The MD reviews the charts and the lab results and performs an examination with the assistance of the RN. The average time required varies with the ESI level of the patients and are given in Table 4. At the conclusion of this examination, based on the condition of the patient, she is admitted into the High-Risk Pregnancy Unit, or to the labor and delivery unit, or discharged.

**Table 4: Time required for examination by the APP and by the MD**

Patient ESI Level	Time in minutes	
	APP	MD
ESI Level 1	12.5	0
ESI Level 2	17	7
ESI Level 3	22	16
ESI Level 4	28	21
ESI Level 5	35	27

**THE MODEL**

The model was set up using ProModel<sup>®</sup> software to simulate one full calendar year with the current level of resources the OBED is currently operating, namely, four examination rooms, one RN and one APP on duty around the clock. A warmup period of one month prior the start of the calendar year was used. The simulation model was run for 50 replications. The results reported here are the average of the results of the 50 replications.

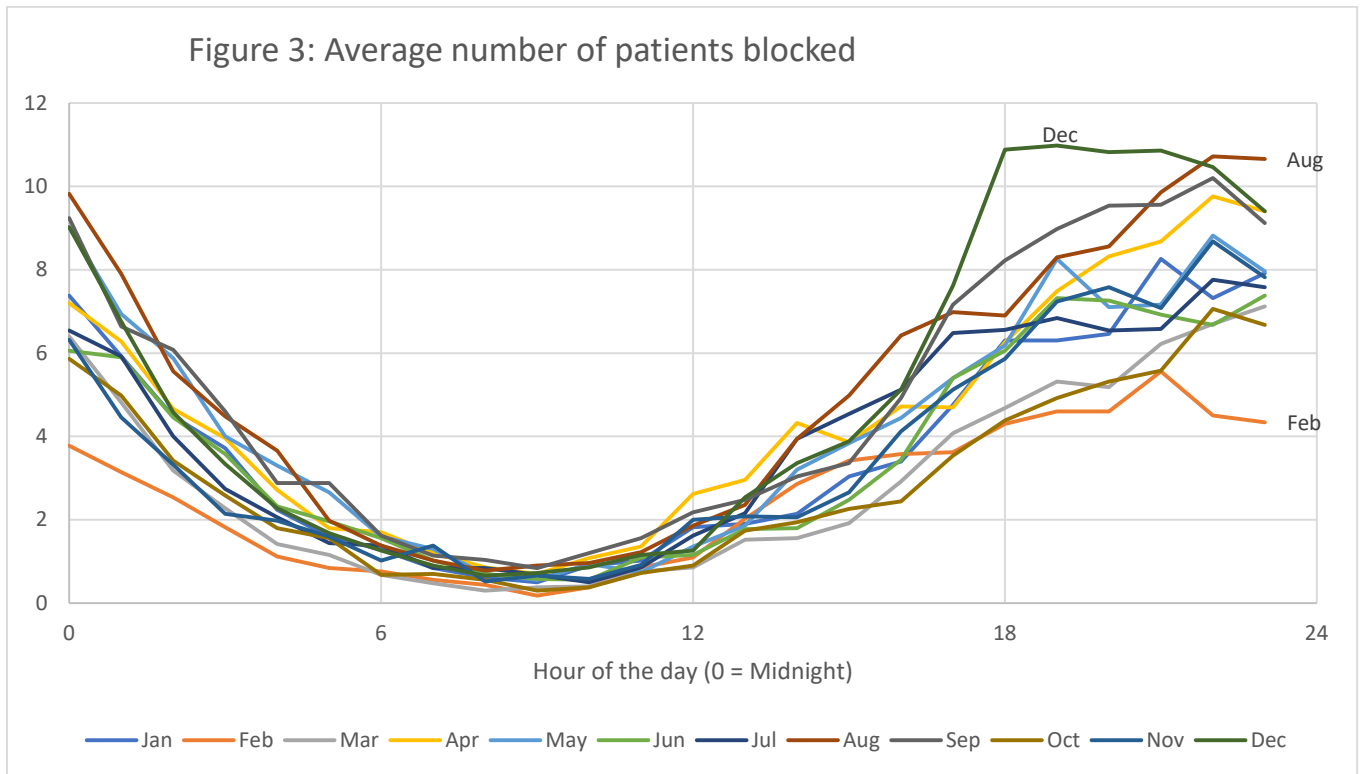
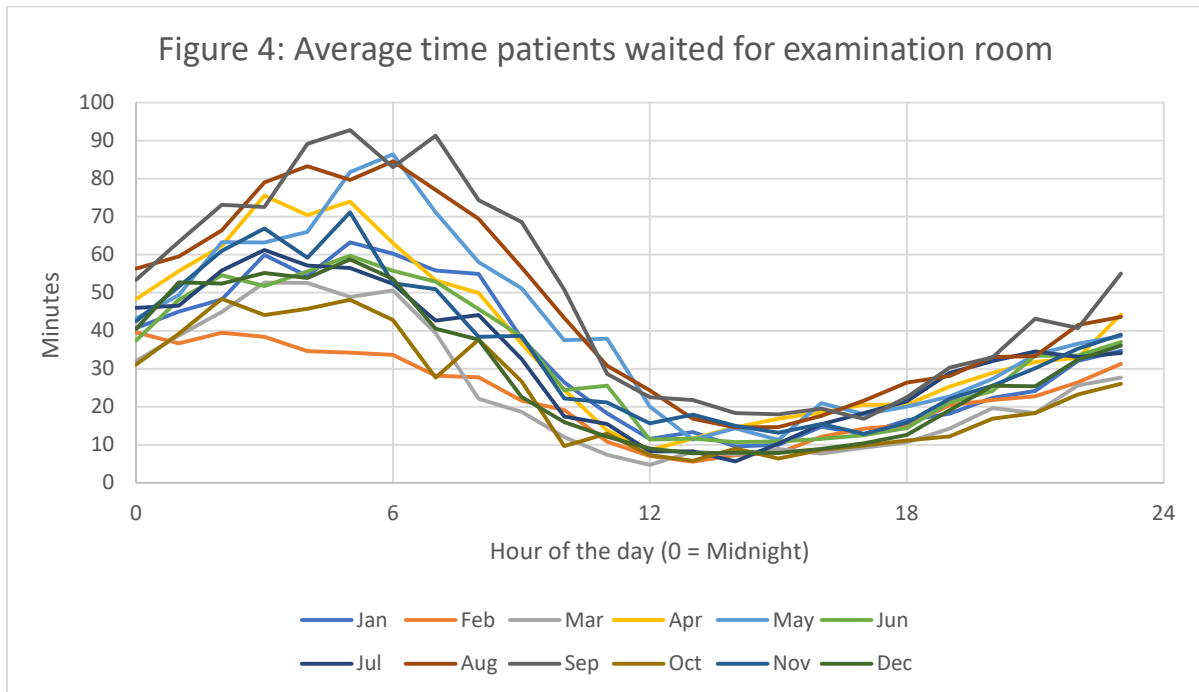

Figure 3 shows on average about 4 to 11 patients had to wait for an examination room because all four were occupied. Figure 4 shows the average in minutes for an examination room. A comparison between Figure 3 and 4 shows that the fewer number of patients are having to wait for an examination, yet the average wait time is relatively long around 30 to 90 minutes. This is the worst case mitigating measures would have been taken for patients with higher level of ESI who were blocked by fully occupied OBED.

**Table 5: Time spent waiting for exam room and time to discharged**

ESI Level	Patients	Blocked	% Blocked	Blocked time (Minutes)		Time to discharge (Minutes)	
				Average	Maximum	Average	Maximum
1	4	0.90	21%	31	106	89	191
2	300	70.68	24%	33	558	225	798
3	3200	751.68	23%	32	714	242	997
4	1295	301.84	23%	32	661	261	949
5	20	4.68	23%	32	282	288	603

Table 5 shows about 1 in 5 patients face fully occupied OBED (Blocked %) and are having to wait for an examination room to open-up on average about half-hour. The maximum time reported here, 714 minutes for ESI Level 3 patients and 661 minutes for ESI Level 4 patients, show what the worst experience would be if no mitigating actions were taken by the staff in duty. In reality, extreme situations such as this would not occur.



Six separate scenarios were considered, with 4, 5, and 6 for number of examination rooms, and for each of these, the lab turnaround times of 100%, 90% or 80% of the current average values. For each scenario, the simulation was run for 50 replications. The results reported here are the average of the results of the 50 replications. The analysis of the results of the simulation with the current level of resources the OBED is currently operating is consistent with the actual conditions experienced by the staff. The two statistics that stand out for remedial action are the percentage of patients who are blocked by fully occupied examination rooms, and the average wait time for one such room to become available. Two possible remedial actions are considered, one to increase the number of examination rooms to 5 or 6, and the second is to cut the lab turnaround time by 90% or 80% of what they are currently. In other words, six scenarios including the current, are considered. The simulation was replicated 50 times for each of the six scenarios. The results presented are the averages of the 50 replications.

Figure 5 shows the percentage of patients who were blocked fully occupied examination rooms and Figure 6 shows the average wait time when blocked. Both plots show the measures for the two remedial actions considered, namely, increasing the number of examination rooms and reducing the lab turnaround time to 90% and 80% of the current time. Both plots show

increasing the number of examination rooms to be more effective in reducing the percentage of patients who had to wait and in cutting the average wait time.

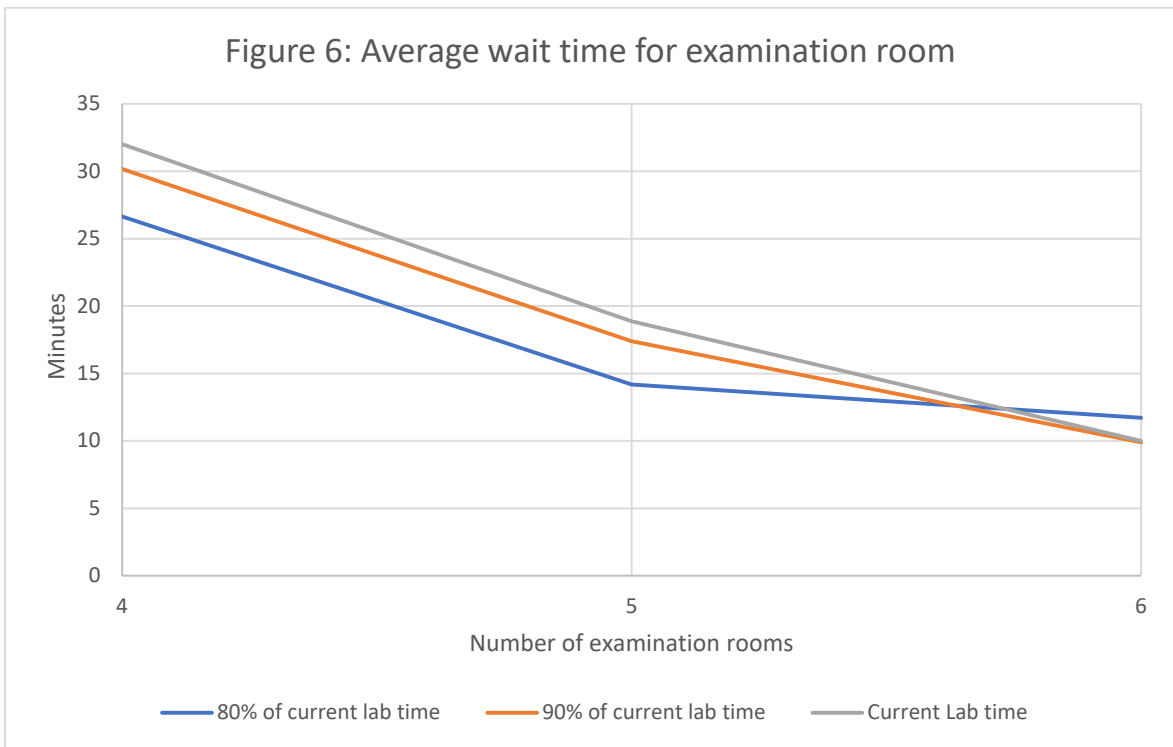
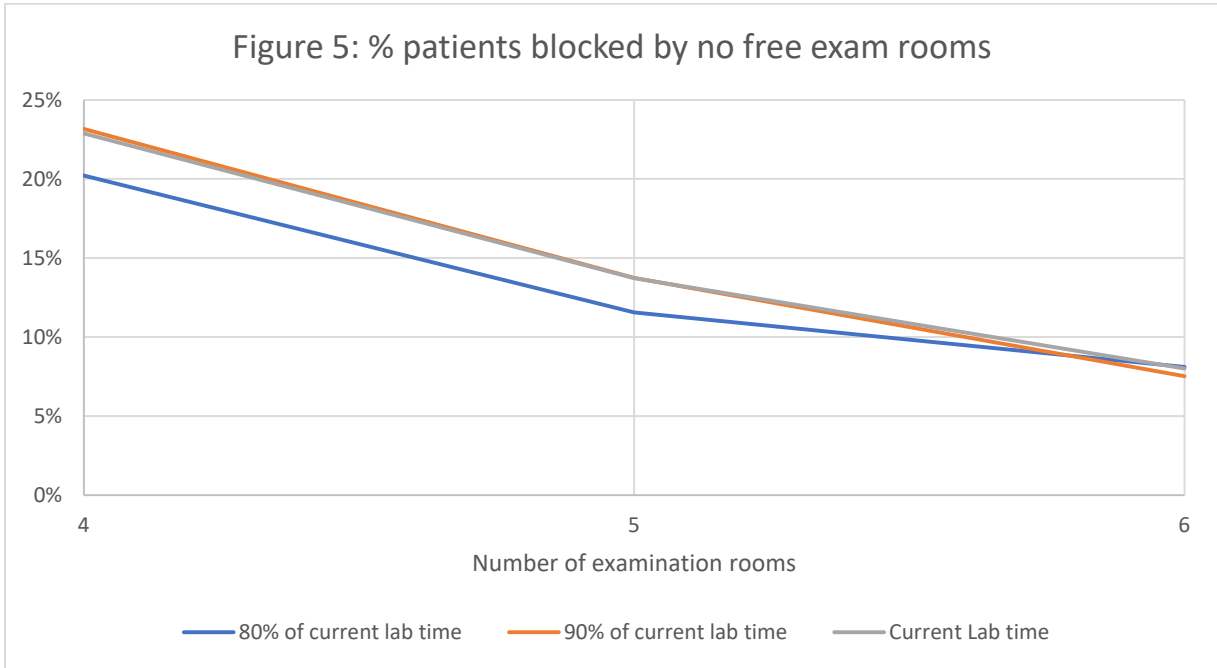

**Extreme cases:**

Table 5 shows some patients may face extreme wait times and discharge times. Patients are not likely to experience such extremes because mitigating actions would be taken. However, it is beneficial to study how to minimize the occurrences of these extreme events. Figure 7 shows the percentage of patients who would be blocked for more than 2 hours and Figure 8 shows the percentage of patients who are discharged 10 hours or later from the time they were admitted. Once again, the figures show increasing the number of examination rooms cuts down the occurrence of these extreme events compared to cutting down lab turnaround time to 90% or 80% of current levels.

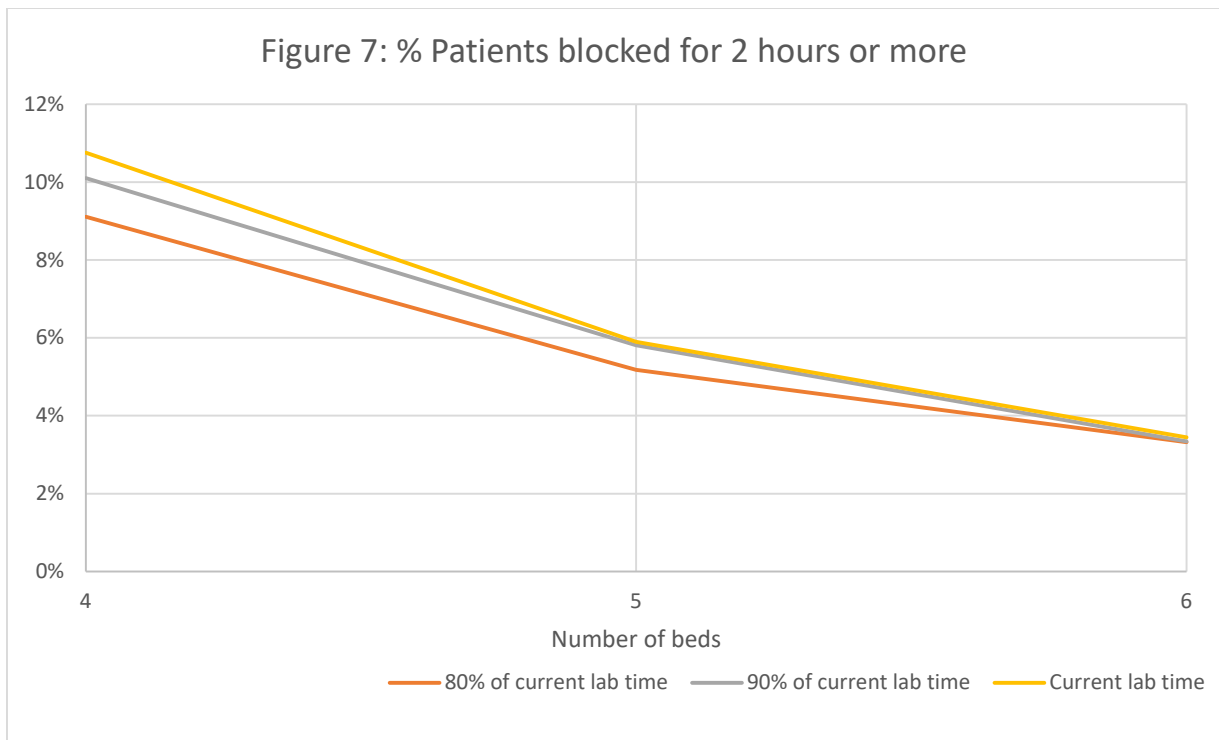

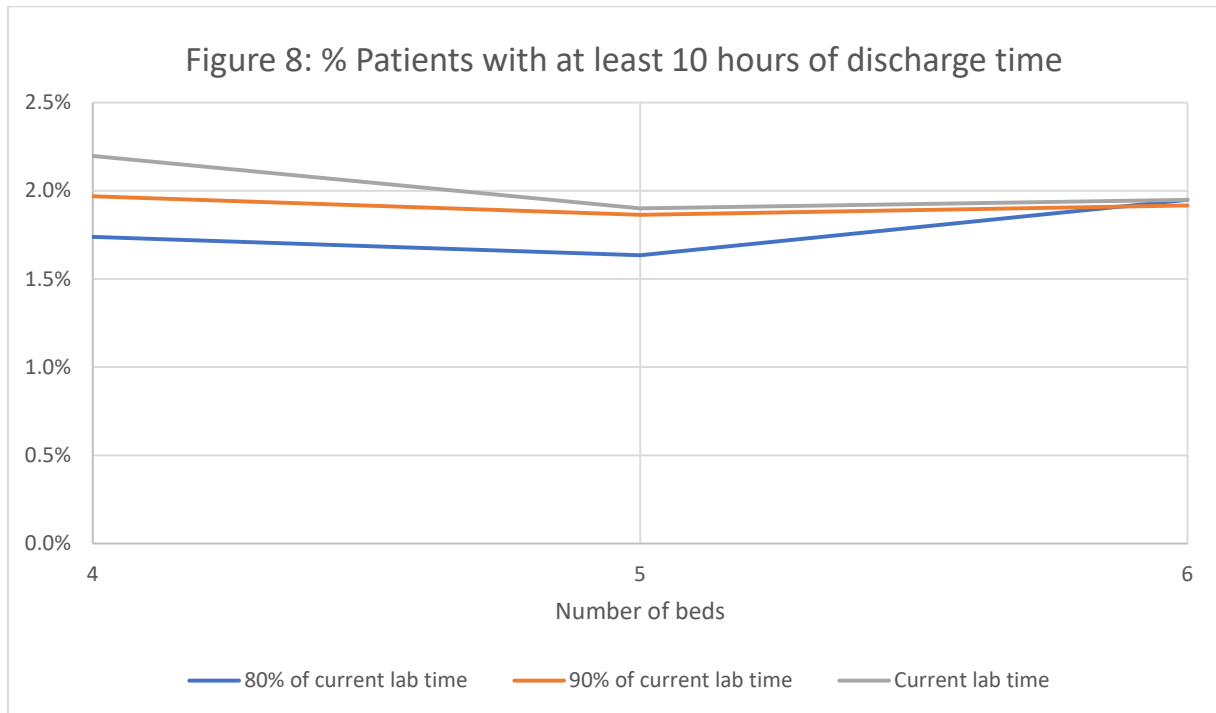

## CONCLUSION

Healthcare is a complex and behemoth industry. It currently accounts for 17% of the United States Gross Domestic Product [15]. The various layers and complexity make it primed for error both on medical decision making as well as ripe for financial grabbles and miscues. This effort reported on an attempt to mesh both issues and improve both patient care experiences as well as financial performance of our unique hybrid model.

Several prior excellent efforts have examined the use of computer simulation in meeting these dual objectives. These efforts have examined the operating theater, emergency departments, pediatric unit, and critical care specialty units. In this paper we present a similar computer simulation model that first examines a single specialty Obstetrics dedicated unit. Our computer simulation analysis identified “bottlenecks” in our delivery of care. This identification has led to efforts to reduce or eliminate those choke points that add to prolonged patient experiences. Reduction in patient time to discharge or admission improves the experience and leads to earlier care implementation.



The application of a computer model maximized our throughput efficiency. This has the potential to result in higher HCAHPS scores, improved patient-provider interactions, fewer re-presentations, and more efficient use of healthcare dollars.

## REFERENCES

- [1] Aldridge, E. S., Rogers, I. R., Bailey, P. M., & Rogers, J. R. (2016). Emergency department 'undercrowding' is associated with decreased waiting times. *Emergency Medicine Australasia*, 28(3), 268-272. doi:10.1111/1742-6723.12569.
- [2] Angelini DJ, Zannieri CL, Silva VB, Fein E, Ward PJ. Toward a concept of triage for labor and delivery: staff perceptions and role utilization. *J Perinat Neonatal Nurs* 1990; 4:1-11.
- [3] Angelini DJ. The utilization of nurse-midwives as providers of obstetric triage services. Results of a national survey. *J Nurse Midwifery* 1999; 44:431-8.
- [4] Angelini DJ, Mahlmeister LR. Liability in triage: management of EMTALA regulations and common obstetric risk. *J Midwifery Women's Health*. 2005; 50:472-8
- [5] Bleustein, C., Rothschild, D., B., Valen, A., Valaitis, E., Schweitzer, L., & Jones, R. (2014). Wait times, patient satisfaction scores, and the perception of care. *American Journal of Managed Care*, 20(5), 393-400.
- [6] Center for Disease Control and Prevention, 2017. <https://www.cdc.gov/nchs/fastats/births.htm>. Web Accessed on November 23, 2017.
- [7] Center for Medicare & Medicaid Services. (2012) <https://www.cms.gov/Regulations-and-Guidance/Legislation/EMTALA/index.html?redirect=/emtala/> Accessed on November 23, 2017.
- [8] Centers for Medicare & Medicaid Services (2014). HCAHPS: Patients' Perspectives of care survey. Retrieved from <https://www.cms.gov/Medicare/Quality-Initiatives-patient-assesment-instruments/HospitalQualityinits/HospitalHCAHPS.html>.
- [9] Chan, Hy & Lo, Sm & Lee, Lly & Lo, Wyl & Yu, Wc & Wu, Yf & Ho, St & Yeung, Rsd & Chan, Jts. (2014). Lean techniques for the improvement of patients' flow in emergency department. *World journal of emergency medicine*. 5. 24-8. 10.5847/wjem.j.1920-8642.2014.01.004.
- [10] Coats TJ, Michalis S. Mathematical modelling of patient flow through an accident and emergency department. *Emergency Medicine Journal* 2001;18:190-192.
- [11] Diercks DB, Roe MT, Chen AY, Peacock WF, Kirk JD, Pollack CV Jr., et al. Prolonged emergency department stays of non-ST-segment-elevation myocardial infarction patients are associated with worse adherence to the American College of Cardiology/American Heart Association guidelines for management and increased adverse events. *Annals of emergency medicine*. 2007;50(5):489-96. Epub 2007/06/23. pmid:17583379.
- [12] Emergency Severity Index (ESI): A Triage Tool for Emergency Department Chapter 1. Introduction to the Emergency Severity Index: A Research-Based Triage Tool. <https://www.ahrq.gov/professionals/systems/hospital/esi/esi1.html>

- [13] Fatovich, D. M., & Hirsch, R. L. (2003). Entry overload, emergency department overcrowding, and ambulance bypass. *Emergency Medicine Journal*, 20(5), 406-409. doi:10.1136/emj.20.5.406.
- [14] Foley M, Kifaieh N, Mallon WK. Financial impact of emergency department crowding. *The western journal of emergency medicine*. 2011;12(2):192–7. Epub 2011/06/22. pmid:21691525; PubMed Central PMCID: PMC3099606.
- [15] Fuchs, VR. The Gross Domestic Product and Health Care Spending *N Engl J Med* 2013; 369:107-109 July 11, 2013. DOI: 10.1056/NEJMp1305298.
- [16] George F, Roussel L. The effect of emergency department crowding on patient outcomes. *Health Science Journal*, 2015; 9(1): 1-6.
- [17] Hardin, L., RN, MSN. (n.d.). Transforming Obstetric Triage Into an Obstetric Emergency Room [Scholarly project]. In *Proceedings of the 2016 AWHONN Convention*. Retrieved from [http://www.jognn.org/article/S0884-2175\(16\)30050-8/pdf](http://www.jognn.org/article/S0884-2175(16)30050-8/pdf)
- [18] Henderson K, Boyle A. Exit block in the emergency department: recognition and consequences. *British journal of hospital medicine (London, England: 2005)*. 2014;75(11):623–6. Epub 2014/11/11. pmid:25383431.
- [19] Holden D, Smart D. Adding value to the patient experience in emergency medicine: What features of the emergency department visit are most important to patients? *Emergency Medicine*. 1999;11(1):3–8.
- [20] Krochmal P, Riley TA. Increased health care costs associated with ED overcrowding. *The American journal of emergency medicine*. 1994;12(3):265–6. Epub 1994/05/01. pmid:8179727.
- [21] Levsky ME, Young SE, Masullo LN, Miller MA, Herold TJ. The effects of an accelerated triage and treatment protocol on left without being seen rates and wait times of urgent patients at a military emergency department. *Military medicine*. 2008;173(10):999–1003. Epub 2009/01/24. pmid:19160619.
- [22] Macones, G. A., Pettker, C. M., Mascola, M. A., & Heine, R. P. (2016, July). American College of Obstetricians and Gynecologists' Committee on Obstetric Practice, Committee opinion number 667: Hospital-based triage of obstetric patients. Retrieved from the American College of Obstetricians and Gynecologists website: <http://www.acog.org/Resources-And-Publications/Committee-Opinions/Committee-on-Obstetric-Practice/Hospital-Based-Triage-of-Obstetric-Patients>.
- [23] Mathews, Kusum & Long, Elisa. (2015). A Conceptual Framework for Improving Critical Care Patient Flow and Bed Use. *Annals of the American Thoracic Society*. 12. 10.1513/AnnalsATS.201409-419OC.

[24] Mohiuddin S, Busby J, Savović J, et al. Patient flow within UK emergency departments: a systematic review of the use of computer simulation modelling methods. *BMJ Open* 2017;7: e015007. doi: 10.1136/bmjopen-2016-015007.

[25] Ozcan, Y. A., Tànfani, E., & Testi, A. (2017). Improving the performance of surgery-based clinical pathways: a simulation-optimization approach. *Health care management science*, 20(1), 1-15.

[26] Paul, J., Jordan, R., Duty, S., & Engstrom, J. L. (2013). Improving Satisfaction with Care and Reducing Length of Stay in an Obstetric Triage Unit Using a Nurse-Midwife-Managed Model of Care. *Journal of Midwifery & Women's Health*, 58(2), 175–181 7p.

[27] Pines JM, Iyer S, Disbot M, Hollander JE, Shofer FS, Datner EM. The effect of emergency department crowding on patient satisfaction for admitted patients. *Academic emergency medicine: official journal of the Society for Academic Emergency Medicine*. 2008;15(9):825–31. Epub 2009/02/27. pmid:19244633.

[28] Richardson DB. The access-block effect: relationship between delay to reaching an inpatient bed and inpatient length of stay. *The Medical journal of Australia*. 2002;177(9):492–5. Epub 2002/10/31. pmid:12405891.

[29] Richardson DB. Increase in patient mortality at 10 days associated with emergency department overcrowding. *The Medical journal of Australia*. 2006;184(5):213–6. Epub 2006/03/07. pmid:16515430.

[30] Rizzo E. The growing movement toward the Ob-ED. *Becker Hospital Review*, 2014. <http://www.beckerhospitalreview.com/hospital-management-administration/the-growing-movement-toward-the-ob-ed> accessed on November 23, 2017.

[31] Sinreich D, Marmor Y. Ways to reduce patient turnaround time and improve service quality in emergency departments. *Journal of health organization and management*. 2005;19(2):88–105. Epub 2005/08/27. pmid:16119049.

[32] Sun BC, Hsia RY, Weiss RE, Zingmond D, Liang LJ, Han W, et al. Effect of emergency department crowding on outcomes of admitted patients. *Annals of emergency medicine*. 2013;61(6):605–11. e6. Epub 2012/12/12. pmid:23218508; PubMed Central PMCID: PMC3690784.

[33] Van Essen, Theresia & Hurink, Johann & Hartholt, Woutske & J van den Akker, Bernd. (2012). Decision support system for the operating room rescheduling problem. *Health care management science*. 15. 355-72. 10.1007/s10729-012-9202-2.

[34] Wiler JL, Gentle C, Halfpenny JM, Heins A, Mehrotra A, Mikhail MG, et al. Optimizing emergency department front-end operations. *Annals of emergency medicine*. 2010;55(2):142–60. e1. Epub 2009/06/27. pmid:19556030.

[35] Zocco J, Williams MJ, Longobucco DB, Bernstein B. A systems analysis of obstetric triage. *J Perinat Neonatal Nurs* 2007; 21:315–22.

## **The Effect of Information Technology Capability and Innovative Capability on Knowledge Management in Healthcare**

Strategic management of organizations depends on the development of distinctive competencies as a means to improve performance over competing organizations and to serve customers. The sum total of the knowledge available within an organization should develop competency through IT capability and innovative capability. The integrated nature of the entire knowledge management capabilities may impact organizational performance. In fact, knowledge management capability is associated with knowledge acquisition, knowledge conversion, knowledge application, and knowledge protection (Gold et al., 2001). Typically, firms seeking to enhance their overall capabilities should first decide on necessary applications, then move to decisions about infrastructure and other required processes in support of the specific application (e.g. how knowledge will be acquired, converted and protected). Focusing on individual knowledge processes provides a more fundamental understanding of a firm's knowledge management capability while enhancing management decision-making at the resource level (Mills & Smith, 2011). The majority of previous research studies of long-term care sectors has focused on reducing deficiencies and improving quality. The objective of this current study is to investigate how information technology capability affects innovative capability and knowledge management in the long-term healthcare sector. Based on the strategic objectives of an organization, knowledge management should identify, capture, structure, and share information to help nursing facilities offer better service, thereby enabling the organization to achieve competitive advantages. Our findings indicate that IT and innovative capabilities are associated with facilities' knowledge management capability in the U.S. long-term care sector. Hence, the success of healthcare depends critically on the utilization of information technology capability and innovative capability in order to collect, analyze, and exchange knowledge within and across organizational boundaries.

### **The Effects of Occupation, Income, and Gender on Psychological Distress in Canada**

Various studies have been conducted on the relationships between psychological distress, socioeconomic status, gender, occupation, income, and lifestyle choices (e.g. fruit and vegetable consumption, physical activities and leisure-time activities). Cockerham et al. (2006) found that females carry a much heavier burden of psychological distress than males. Furthermore, their study revealed that less distressed females and males consumed a more balanced diet than more highly distressed persons. Cadieux and Marchand (2014) indicated that the level of psychological distress is significantly lower among professionals in regulated occupations than among professionals working in non-regulated occupations. However, Bultmann et al. (2001) did not find significant relationships between psychological distress and occupations. Drapeau et al. (2014) found the mean level of psychological distress to be higher in women than in men in all age groups; also, individuals in the 18-29 age group reported higher distress levels than older Canadian adults. The contexts of these various studies are generally different, and the results are not always consistent. The purpose of this study is to provide a close examination of a wider population to identify how factors such as gender, occupation, income level, and lifestyle choices affect an individual's distress level. In this paper, the Canadian Community Health Survey (CCHS) dataset is utilized to conduct our study of a sample of 14,089 people in Canada. The results indicate that among five occupation groups, individuals in the sales and services category have significantly higher distress levels than the other four groups. Additionally, the results also reveal that people with personal incomes of less than \$20,000 annually perceive significantly higher distress levels than all other groups. Furthermore, we found that lifestyle choices have a strong impact on distress levels; specifically, higher fruit consumption, as well as reduced time spent on leisure/physical activities, can reduce distress levels. Moreover, females seem to have higher distress levels than males. Finally, this present study shows that people who have longer commuting times perceive higher distress levels.

## **THE IMPACT OF BACKORDERS ON THE HEALTHCARE SUPPLY CHAIN**

### **ABSTRACT**

Backorders are a major issue within healthcare supply chain management. Backorder processes are informal and reactive which hinders supply chain efficiency. This research study summarizes interviews with two healthcare organizations (HCOs) regarding backorder difficulties with manufacturers. In addition, a representative from a third party logistics organization (3 PL) was interviewed for further insight. Interviewees shared recommendations based on their experience within the industry. It was discovered that internal and external communication, technological resource utilization and vendor credentialing measures have the potential to decrease issues caused by backorders. These recommendations may lead to best practices for the healthcare supply chain industry once validated. However, further research is necessary to determine the effectiveness of these approaches.

Keywords: backorders, supply chain, healthcare, management, communication

## **THE IMPACT OF BACKORDERS ON THE HEALTHCARE SUPPLY CHAIN**

Healthcare is the fastest growing section of the economy [5]. Its high growth rate is linked to the aging “Boomer” population and the effects of the Affordable Care Act. Healthcare spending makes up almost 18 percent of the United States’ Gross Domestic Profit [7]. Much of the healthcare spending is made up of administrative costs, which include the processing of backorders [9]. Backorders are orders for goods that currently cannot be filled because of a lack of supply. Administrative spending within the healthcare industry accounts for eight percent of the GDP [7]. A Cardinal Health survey found that 18 percent of healthcare organizations have seen or heard of patients being negatively affected by a lack of necessary medical supplies [8]. Medical staff spent almost 20 percent of their time on inventory management [8]. However, the same report showed that only 17 percent of HCOs surveyed do not have a technology system to automatically track inventory in real time [8].

Backorders plague almost all industries, but they are especially harmful to the healthcare industry because of its critical nature [1]. There is a vital need for healthcare organizations to accurately track and communicate backorders. This case study focuses on backorder issues that HCOs face with their manufacturing suppliers. Two healthcare organizations were interviewed to understand the backorder issues they face. Currently, there are few, if any, best practices to help HCOs prevent backorders. This research aims to comprehend and summarize the backorder issues that healthcare organizations face and suggest areas for further research.



## LITERATURE REVIEW

When first conducting research for this topic, it was common to find literature on supply chain management, healthcare organizations, and back orders. However, there was little information on the combination of medical supply chains and their backorders. E-commerce was one of the topics that matched with the processes for medical purchasing, but it was not integrated into the supply chain for backorders [6]. There are multiple reasons for backorders.

E-commerce is the use of electronics and the internet to create, place, and complete product orders [6]. One of the most obvious reasons to use electronic ordering is the shortened time commitment to communication. Fast-paced environments need to cut time as often as they can [6]. Ursula and Elmhurst, in their book *Ebusiness in Healthcare: from e-procurement to supply chain management*, go over the importance of the online systems integration with both purchasers and the clinicians for simplified purchases. The systems hold the information about vendors and suppliers along with what items are already approved and the time it takes to get them from the placement of the order [6]. Ursula and Elmhurst also found in their study the changing between systems for what each healthcare organization prefers with the individuals needs and the merging of different medical areas purchasing the same items at different times. These systems need to cooperate with each other to create smooth orders and supply flow, yet often difficulties arise when using more than one type of system [6].

When it comes to vendor and supplier relations, often times they can be strained when backorders start to pile up over time. John Diconsiglie has an interesting article in *H&HN: Hospitals and Health Networks* that shows rising tension between vendors and purchasers, but also shows the willingness of other healthcare facilities to help provide supplies in times of need [4]. At the time of this article, the supply chain workers already saw the increase of backorders and planned for future growth unless new ways of communication and work were implemented to help inform buyers before they happened [4]. Material managers work closely with suppliers to get the best products at the right time for the right price [4]. This is the ideal goal but not as easily achievable as one might hope. Security of supply is a large factor for any product and has documentation of its importance [4]. For medical products like insulin and other seemingly common products, the importance of supply security is still vital [2]. There are three main points that David Beran uses in his writings on supply security in the medical field [2]. One is uninterrupted supply or constant use of safety stock in ordering vital products [2]. There needs to be a sustainable supply of the product as well as continuous growth in the market and competitiveness of new and old businesses [2]. David's last point is on the importance of the quality of the supply and product [2]. All of these points work in normal supply chains and the medical fields [2]. These criteria are able to help decipher between different vendors and suppliers for specific products and medical facilities [2].

Backorders have been proven to further the consequences of the bullwhip effect [3]. The term “bullwhip” was first coined by the logistics department at Proctor and Gamble [3]. The bullwhip effect describes how small demand fluctuations at the retail level can have greater effects in demand at the distributor, manufacturer and supplier levels [3]. When demand shocks occur, firms first change their lead times through the depletion of backorders. Then, inventories are adjusted, and production is changed. However, just-in-time techniques have reduced the need for backorders to smooth over demand shocks [3]. With adjusting production and inventory controls, firms respond faster to these shocks [3]. This drives down the delivery times, so intermediate goods producers know they can receive their raw materials quicker if they experience a demand shock [3]. Because of this, intermediate goods producers don't make the large and irregular orders when lead times are low [3].

Suppliers for healthcare organizations across the country are faced with the make-to-stock or make-to-order strategy. Make-to-stock is a proactive decision to have excess stock of medical items to hedge against the risk of running out of stock [9]. This strategy is more disciplined and relies heavily on inventory management. It is a push strategy where demand forecasts are the focus. The make-to-order scenario is reactive and aims to meet the exact actual demand of products on an as-needed basis [9]. This strategy forces suppliers to be adaptable to current customer demand instead of future demand. Often, make-to-order strategies utilize just-in-time deliveries with faster modes of transportation. It is a pull decision where customization and quick responses are critical. Usually, make-to-order is utilized downstream in a supply chain and make-to-stock is used upstream [9]. The delivery of supplies to healthcare organizations is a large portion of hospitals' operating budgets. This occurs because of the high costs associated with obsolescence-prone drugs and medical supplies. In emergency situations, premium modes of transportation are used for critical items, which greatly increase costs. Also, the distribution and marketing channels for healthcare organizations are more complex and incur higher costs [9]. Since healthcare logistics are in need of waste-elimination efforts to drive down costs, many hospitals are using point-of-use distribution.

### **DATA COLLECTION AND ANALYSIS**

Backorder and inventory data was collected through interviews within a restricted geographical region. Research aimed to learn of the issues that HCOs face concerning backorders. The interviewees were picked from networking during the SCSHMM Spring Conference. Interviewees were asked the questions listed in Appendix A to gain insight on the size of their organization, their supply chain backgrounds, specific pain points that backorders cause and recommendations to reduce the impact of these pain points. Two HCOs from South Carolina were interviewed. Both had different numbers of facilities, number of beds and revenue amounts. Below, Table 1 compiles the features of the HCOs interviewed. Interviews were conducted over the phone or in person and interview information was written down. Table 2 provides

information concerning representatives of each HCO interviewed in this study. In addition, a representative from an HCO distributor was interviewed to gain a perspective of the effects that backorders have through a supply chain. Information from the interviews is summarized below in order to determine common issues and potential solutions related to backorder problems.

**TABLE 1****HCO Characteristics**

<b>Identifying Label</b>	<b>Total Beds*</b>	<b>Number of Facilities*</b>	<b>Patient Revenue*</b>	<b>Public or Private</b>	<b>Trauma Level***</b>
<b>HCO 1</b>	<b>600</b>	<b>60</b>	<b>\$2,376,179,078</b>	<b>Private</b>	<b>III</b>
<b>HCO 2</b>	<b>352</b>	<b>107</b>	<b>\$1,175,331,337</b>	<b>Private</b>	<b>I</b>

\*Counts and values are estimates based on interview responses and publicly accessible data

\*\* For HCOs with multiple hospitals, the highest trauma level is listed

**TABLE 2****Interviewee Statistics**

<b>Organization</b>	<b>Title</b>	<b>Years of Experience in Healthcare Industry</b>
<b>HCO 1</b>	<b>Materials Management Contracts Specialist</b>	<b>38</b>
<b>HCO 2</b>	<b>Supply Chain Manager</b>	<b>6</b>
<b>3 PL 1</b>	<b>Director of National Accounts</b>	<b>20</b>

## RESULTS FROM INTERVIEWS

### HCO 1

A representative from HCO 1 discussed the challenges that HCOs face in regard to backorders. The biggest cause of backorders ties into timing. This can be from shipping mishaps, underordering of products, both local and vendor based, manufacturing issues, natural disasters, or any combination of these issues. The occurrence of backorders has increased yearly, which invokes the need for unified information on the subject. Another issue that backorders create are finding substitutions for backordered products. Substitutions are items that are of the same basic design as the original product but with slight variations. Some items are simple and, therefore, are easy to substitute. Other products require approval from manufacturers, clinicians, and the doctors using the items. This is one of the reasons a list of approved substitutions is not readily available for healthcare facilities. The clinicians and doctors at one facility may have different views on one or more items that do not match with the other facility. Approximately 25% of the time, backordered items will need to be substituted in order to not lose rescheduled work. There are times where the dependency for an item will outweigh the costs or quality desired for normal uses which can be a drain on resources. Substitution lists would be useful; however, there is the problem with other facilities ordering or using up all the items needed before another has time to order them for their own use. The data on manufacturers and vendors will help with comparing the items against what each facility already uses and who to purchase them through. Some items may not have substitutions. In this case, the end users are informed of backorders and their usages are lowered until the items are no longer backordered.

### HCO 2

A representative from HCO 2 described the main reasons for backorders and how their team manages them. One cause is manufacturing backorders. Manufacturers get behind in their production schedule or they have issues with their production lines at their manufacturing plant, and it slows down production. There are two ways for HCOs to get supplies: directly from the manufacturer, or from a distributor. A distributor backorder occurs when a distributor fails to order enough inventory to meet our supply. The best way to work through backorders is communication. HCO 2's current backorder process is to first look at days on hand stock. Days on hand stock is based off of usage which is found in the enterprise resource planning (ERP) system. If it is less than five days on hand, then the buyer for that item is told to buy directly from the manufacturer or from a different distributor. If those two options are not available, then the buyer is told to find a substitute. Often, the distributor will offer a substitute, or they will advise to go straight to the manufacturer themselves. Substitutions in the healthcare field can be difficult. If a substitution is needed, it goes through the value analysis team. This is a team of

clinical nurses that have to test and approve substitutes. Once they identify a substitution, then it will be marked as approved within the ERP system. If that item is on backorder ever again, the list of approved substitutions appears with the ERP system, and substitutes are ordered. However, the clinician approval process usually occurs once an item is already on backorder, which can cause time-management issues. There should be a way to communicate backorders with other HCOs, especially when national backorders happen. The FDA should provide substitutes when its policies and rules change because these changes often lead to backorders. When the users, doctors or nurses, start to administer a different amount of a product, they should inform the HCOs supply chain department. This could allow inventory levels to be adjusted in the future. Because informing supply chain is often an afterthought, HCOs may cause their own backorders when they change usages.

### 3 PL 1

A third party logistics representative gave insight on what causes backorders. Mergers within the manufacturing community can cause backorders. To make their books look good, these mergers try not to spend money on excess inventory, which causes a backorder problem. Also, the FDA can cause problems without considering the effects on the supply chain. The FDA does not realize its sudden policy changes are causing harm to patient care. Usage spikes, recalls and manufacturing errors also cause backorders. 3 PL 1 also described its substitutes verification process. Substitutes have to be run through a clinical value analysis at the individual hospitals. Sometimes, HCOs have to re-write policies based on the item if it is drastically different from the current process. Occasionally, HCOs have to train nurses on the substitute. This is especially true if the item is something that newer nurses have never seen before or if they are doing an older method for something that is backordered. The 3 PL works with each hospital to try to identify their critical items, but that is time consuming and difficult. As soon as a substitute list is made, items become obsolete. The 3 PL keeps notes on backorders so they can make suggestions of what they had previously used in the past. There are hardly any substitute matches between hospitals, so distributors have to go hospital-to-hospital and maintain a substitute list for each HCO.

Organization	Issue	Cause
HCO 1	Resource-Change Backorders	Lack of clinical integration
HCO 2	Usage-Spike Backorders	FDA Changes
3 PL 1	Manufacturing Backorder	Lack of communication with manufacturers

## DISCUSSION

All interviewees faced different issues when it came to backorder management. However, there was a common theme with their current process for backorders: it is informal and reactive when it should be formal and proactive.

The pain points for HCO 1 surrounded communication issues. One area that needs improvement is the current clinician approval process. There is little formal communication between the supply chain department and clinicians in regard to low inventory levels. These communication issues often lead to compromised patient care when critical medical items run out of stock and require extended amounts of time to be restocked. Also, communication issues down the supply chain are often a struggle for HCO 1. Often, when a manufacturer does not communicate a backorder to a 3 PL, the HCO does not know if the backorder issue until their inventory levels are critically low.

HCO 2 explained that its current distributor communication process is effective. The distributor sends a list of backordered items every time that the HCO places an order. This gives the HCO enough time to look at its stock and see if they have enough inventory based on usage. The usage is found through the ERP system. HCO 2 also mentioned communication issues when it came to clinician integration. Its current process for clinical approval of substitutions is reactive instead of proactive. This means that clinicians are approving substitutions after there is already a backorder. The approval process takes time that often is not available when critical items are on backorder.

3 PL 1 stated that they try to be proactive in their backorder management process, but it can be very difficult with the number of purchase orders they receive daily. Their current process is to attempt to gather the purchase orders that are nearing their due date and track them to see if they have a backorder. If they do, then the distributor tries to transfer enough inventory to cover a shipping delay from the manufacturer. They have to communicate delays to the end user so they are not caught with patients that they can't care for.

Based on these examples from the HCOs and 3 PL, it is clear that backorders processes are reactive and informal because of a lack of proper communication. Since medical staff spend almost 20 percent of their time on inventory management, it is critical to find solutions to pain points like backorders. There are several areas for improvement within backorder management processes. Interviewees provided suggestions for improving healthcare backorder solutions by creating clear and consistent expectations within and outside of their ERP system. Currently, HCOs add backorder information into their ERP system only after a backorder has occurred. This feeds into the reactive aspect under which that healthcare organizations currently operate. Also, the interviews provided insight into the wide variety of items that go on backorder. There

was no correlation found of common items that go on backorder within different healthcare organizations.

With the input of the South Carolina Society of Hospitals Materials Management (SCSHMM), a survey was created to gauge how well HCOs are currently managing backorders. The survey included eight questions in a multiple choice format. The first question asked interviewees how often they personally dealt with backorders. Next, they were asked how often does the clinical staff report inventory levels back to the supply chain department. The research participants were also asked approximately what percentage of their substitutions were in their MMIS systems. The fourth question asked was what percentage of HCOs' manufacturers send out a substitution list. Next, a Likert scale was given for Hospital Material Managers to rate their frustrations level with managing backorders. They were also asked to rate the vendor hospital communication process. Next, they answered how clear they understood the internal backorder communication process in their organization. Last they were asked what kind of effects that substitution costs were having on overall costs.

### **RECOMMENDATIONS**

At the end of the survey, a list of recommendations was added to help improve the management of backorders. These recommendations are mentioned below and will be used as a guide to determine best practices to control backorders. The first recommendation is for HCOs to publish a backorders list for clinicians to approve. This will allow the entire supply chain and clinician teams know what is already approved for their system and what still needs to be done. The cutting down of time by publishing a list will greatly improve the supply chain procurement by lessening time spent tracking down information from other sources. The second recommendation is for clinicians to perform weekly check-ins of what's on the shelf and communicate this to the supply chain department. If inventory levels and possible usage spikes are clearly communicated, the purchasers can react accordingly to prevent an out-of-stock situation.

Another recommendation is for HCOs to add substitutions to their MMIS systems for easy access. Easy access to the substitutions makes for a quicker response time when backorders occur. It is also recommended for HCOs to require manufacturers to sign a vendor credential form that requires vendors to provide substitutions and/or offer other solutions. These forms would also include specifics about backorder communication requirements for vendors. Getting vendors and manufacturers to share information about their products and competitors may not be easy, but it will help with the rising backorders issue. Specifications about substitutions should come from the manufacturer in order to have a more accurate understanding of what is a proper substitute. The final recommendation is for HCOs to send their vendors a quarterly update on how well they are adhering to the HCOs credential requirements. Sending updates may already be a part of the system for rating and choosing suppliers. It can also be helping in creating more

communication and understanding between the parties. If either group is having issues, each side can let the others know sooner about what is happening.

### **LIMITATIONS OF RESEARCH**

The number of interviews conducted was a limitation of this research. Limited interviews caused the basic understanding of backorders to be underdeveloped in some areas. The three interviews provided a strong basis of understanding, but it would have been beneficial for more interviewees to provide input on their experiences. The limited time frame for which the research was conducted was another limitation. Conducting this research over a longer period of time would allow for more interviews and discussions on the topic of backorders. The longer the research time, the more in depth the researchers can go into each aspect of the problem and solutions.

### **FUTURE RESEARCH OPPORTUNITIES**

Given the timeline constraints of this research, there are opportunities for future research. This can be done by creating an additional survey to track HCOs improvement in their backorder management process. Some of the recommendations in the survey may need to be updated as new ideas and innovations arise. There is also an opportunity for the backorder process recommendations to be validated so that they can be considered best practices for the industry. In order for this to happen, great process improvement would need to occur in a wide variety of healthcare organization settings. Expanding the research to other geographical regions may also help aid in understanding the overarching issues and how they need to be addressed.

### **CONCLUSION**

This paper examines the backorder management issues that HCOs experience. After conducting research through interviews and literature reviews, it was determined that the current processes for backorder management are reactive and informal. To lessen the pain points caused by backorders, these processes need to be proactive and formal. Interviewees recommended five strategies to help make this transition possible. Further research will need to be conducted to see if the recommendations can be validated to be best practices for the healthcare industry as a whole.



## **APPENDIX**

### **Interview Questions**

1. How do you currently manage backorders?
2. How long does it usually take your organization to resolve backorder issues?
3. Are there usually substitutions for critical items?
4. Who approves the substitutions in your HCO?
5. Is the approval of substitutions a proactive process?
6. Would you be willing to share a substitution list with other HCOs or would they need to do their own approval methods?
7. How do you manage backorders with items that have no substitutions?

**REFERENCES**

- [1] Abbey, J. D. (n.d.). Analyzing impacts on backorders and ending inventory in MRP due to changes in lead-time, demand variability and safety stock levels. doi: 10.31274/rtd-180813-16590
- [2] Beran, David, et al. "Access to insulin: applying the concept of security of supply to medicines/Acces a l'insuline: application du concept de securite d'approvisionnement aux medicaments/Acceso a la insulina: aplicacion del concepto de seguridad en el suministro a los medicamentos." *Bulletin of the World Health Organization*, May 2019, p. 358+. *Gale OneFile: Health and Medicine*, [https://link.gale.com/apps/doc/A593028265/HRCA?u=anderson\\_cl&sid=HRCA&xid=8fa8164a](https://link.gale.com/apps/doc/A593028265/HRCA?u=anderson_cl&sid=HRCA&xid=8fa8164a). Accessed 3 Oct. 2019.
- [3] "Beyond Inventory Management: The Bullwhip Effect and the ..."  
<https://www.aeaweb.org/conference/2014/retrieve.php?pdfid=1079>.
- [4] Diconsiglio, John. "As Back Orders Mount, Tensions Rise Between Hospitals and Vendors." *H&HN: Hospitals & Health Networks*, vol. 82, no. 9, Sept. 2008, p. 20. *EBSCOhost*, [search.ebscohost.com/login.aspx?direct=true&db=hch&AN=34509926&site=ehost-live](http://search.ebscohost.com/login.aspx?direct=true&db=hch&AN=34509926&site=ehost-live).
- [5] Healthcare Occupations : Occupational Outlook Handbook. (2019, September 4). Retrieved from <https://www.bls.gov/ooh/healthcare/home.htm>.
- [6] Hübner Ursula, and Marc A. Elmhurst. *EBusiness in Healthcare: from EProcurement to Supply Chain Management*. Springer, 2010.
- [7] "NationalHealthAccountsHistorical." CMS.gov Centers for Medicare & Medicaid Services, 11 Dec. 2018, <https://www.cms.gov/Research-Statistics-Data-and-Systems/Statistics-Trends-and-Reports/NationalHealthExpendData/NationalHealthAccountsHistorical.html>.
- [8] Newswire, MultiVu - PR. "Survey Finds Hospital Staff Report Better Supply Chain Management Leads to Better Quality of Care and Supports Patient Safety." Multivu, <https://www.multivu.com/players/English/8041151-cardinal-health-hospital-supply-chain-management-survey/>.
- [9] RevCycleIntelligence. "Prices, Administrative Costs Drive Higher US Healthcare Spending." RevCycleIntelligence, 14 Mar. 2018, <https://revcycleintelligence.com/news/prices-administrative-costs-drive-higher-us-healthcare-spending>.

## Universal Basic Income and the Impact on Health

By

Dr. Peggy Johnson, Lander University

Dr. Stanley Vinson, Lander University

### Abstract.

The following is an abstract investigating literature relating to Universal Basic Income and the impact on the health of a population receiving a payment under this system that would essentially increase the income of all individuals. Universal Basic Income or UBI, is a version of Social Security that allows all citizens of a country to receive an amount of money each month that is not dependent on their work status or income. UBI is a term that means that the government distributes cash universally without regard to income. The concept of basic income has gained supporters throughout the world. It is being acknowledged by social thinkers as a way of transforming capitalism into a more just vehicle that is equally distributing gains and by the tech community as a way of helping deal with job displacement as a consequence of technology. In various forms, UBI has captivated activists and intellectuals since the 1500, with pilot projects and experiments being done throughout the world. Many who have labored in health care over the decades have long recognized the link between poverty and poor health and consider UBI an alternative worth investigating.

### Introduction

Although there are many experiments that measure the effects of UBI, in Stockton California there is a new one being done that has almost reached the halfway mark of its three year trial. Started in 2018, a select group of residents received \$500 a month, without constraints on how they spend the money. Stockton Mayor Michael Tubbs drove this initiative and is a proponent of basic income, believing it can help alleviate the persistent poverty in his city. The UBI concept, which has some roots dating back to the Civil Rights Era, has recently gained more national traction with many others including Democratic presidential candidate Andrew Yang who has politicized the solution in his presidential campaign. Promoting the idea as necessary to prepare for a future when automation makes most jobs obsolete, Yang and others like tech founders like Mark Zuckerberg and Elon Musk have proposed all Americans be paid a “freedom dividend” of \$1,000 a month.

Mayor Tubbs is quoted as saying that In Stockton, like much of America, citizens have a Puritan ethos of, ‘I work hard and if you don’t work, you shouldn’t eat’. Mayor Tubbs hopes the Stockton experiment will illustrating there are people who are working hard and struggling, not because they’re lazy, but because wages haven’t kept up with inflation and daily living expenses.

In Stockton each recipient was given a debit card that automatically loads the monthly payment that allows researchers to track spending. To date, 40 percent of the money went towards food, 12 percent went to utility payments, with the remainder spent on various merchandise purchases. According to Stacie Martin-West, an assistant professor at the University of Tennessee College of Social Work and the co-principal investigator on the project, “the economic decisions made during the first months of the program have been really rational.” This success parallels many of the other UBI experiments around the world, although the ultimate outcome of this one is yet to be determined.

### Healthier Means Wealthier

The positive correlation between health and income per capita is one of the best-known relationships in international development according to Harvard economist David Bloom. Bloom’s says that empirical studies show that health improvements provide a substantial elevation to economic growth in developing countries. The popular view theorizes that health, like education, is a fundamental component of human capital, and suggests the notion of health-led growth. Bloom explains that better health leads to higher income, but there is also a positive feedback effect, which allows an advantageous situation where health and income improvements are mutually reinforcing (Bloom and Canning, 2000).

The first major advance in recent years in our understanding of economic growth has to do with the link between population health and economic growth. Generally, economists have believed that population health is a consequence of economic growth, and that health is just a social indicator that improves when incomes grow. Which makes sense, when people have more money, they tend to have better nutrition, better access to safe water and sanitation, access to more and better health care, and better psycho-social resources like community recreation facilities and mental health counseling. Many studies have shown this positive association between health and income. Causality has not been proven in these studies, economists think that perhaps causality could run in the other direction, from health to income. Economists have rigorously explored this possibility for the past two decades, which is quite plausible. Consider that a healthier workforce is naturally a more productive workforce. Additionally, healthier children tend to have better school attendance, remain in school longer, have higher cognitive function, and achieve more in school. Also, healthy populations have higher savings rates as people save more in anticipation of longer periods of retirement. And finally, healthy populations are like a magnet when it comes to attracting foreign direct investment. (Bloom DE, Canning D, Fink G.)

Between 2011 and 2013 in the United States, 38% of the households with incomes less than \$22,500 per year reported being in poor or fair health. Only 12% of households making more than 47,700 per year reported being in poor to fair health during the same time period (Wolfe, et al, 2015).

The returns achieved by investing in health are remarkable. There are reductions in mortality that account for about 11% of recent economic growth in low-income and middle-income countries as measured in their national income accounts. (Jamison, et al 2013)

In Canada in 1974-1979 a Canadian guaranteed annual income experiment started. The experiment used health administration data to document an 8.5 % reduction in the hospitalization rate of the participants, particularly for accidents, injuries and mental health admissions. The study also found that physician visits dropped, notable for mental health. Additionally, more students stayed in school and entered 12<sup>th</sup> grade. There was no increase in fertility or family dissolution rates.

Guaranteed annual income in American also started during the 1970s. The civil rights movement of the 1960s revealed to ordinary Americans the persistence of poverty in the United States despite the tremendous economic growth of the postwar era. Introductions of programs by the Democrats included AFDC, Social Security Amendments and other initiatives in President Johnson's War on Poverty. The most well-known advocate at the time was Milton Friedman and support was fairly widespread according to health researcher and commentator Evelyn Forget. The North American GAI experiments were based on the idea of a negative income tax. Many believed the more unyielding poverty was that of the working poor and that a GIA would be more effective at reducing poverty in low-income workers than the existing programs of that day. The political climate changed from support to experimentation under Richard Nixon and the experiments that were completed in several states and the results were hotly debated by both liberals and conservatives. The political right mobilized and opponents of welfare reform seized upon the results of the experiment to prove that a GAI was unworkable. The results that showed very modest effects on work effort were portrayed as disastrous for the labor market. Many of the advocates of GAI withdrew support having received erroneous results from the experiment (Forget, 2011).

#### Whitehall Studies

Dr. Michael Marmot in 1967 England, completed the study examining the connection between health and wealth. The Whitehall study of 18,000 men in the Civil Service was initiated. The initial Whitehall study showed that men in the lowest employment grades were much more likely to die prematurely than men in the highest grades. The second Whitehall study was set up to determine what underlies this phenomena in death and disease and to include women. Income levels in both studies predicted disease burden and mortality.

The second study examined the independent impacts of income and wealth on the burden of illness. Income is highly correlated with the level of employment, so much so that once the level of employment was accounted for, income made no additional contribution to predicting illness. Wealth is a predictor of illness and represents a balance of income and expenditure over the entire lifetime, including wealth that was inherited from previous generations.

The Marmot studies of British civil servants identified an association between wealth and health and may represent the effect of accumulation of material and psychosocial factors on health. Additionally, wealth links to financial security and prospects for the future and can have an impact on rates of illness. The 1967 Whitehall study showed a steep inverse association between social class, as assessed by grade of employment, and mortality from a wide range of diseases. The study was repeated between 1985 and 1988 and investigated the degree and causes of the social gradient in morbidity in a new cohort of 10 314 civil servants (6900 men, 3414 women) aged 35-55 (the Whitehall II study). Participants answered a self-administered questionnaire and also attended a screening examination. The results indicate that in the 20 years separating the two studies there has been no decrease in social class difference in morbidity: we found an inverse association between employment grade and prevalence of angina, electrocardiogram evidence of ischemia, and symptoms of chronic bronchitis. As in the first study, self-perceived health status and symptoms were worse in subjects in lower status jobs (Marmot, et al. 1991).

The obvious facts of poverty are increasingly difficult to ignore. For instance, infant mortality and children's health are strongly linked to family income and maternal education. Low birth weight infants highest among babies born to low-income mothers. Children in poor families are roughly four times more likely to be in poor or fair health as children in families with incomes at or above 400 percent of the FPL. Children from low-income families experience higher rates of asthma, heart conditions, hearing problems, digestive disorders, and elevated blood lead levels. Poor children also have more risk factors for disease, such as childhood obesity and hypertension (Wolfe, et al, 2015).

Other studies offer similar conclusion concerning wealth and the resulting social status differences on health, however, the opportunity to investigate the impact of a Universal Basic Income on health, helps us develop increased understanding of the impact of increased wealth on the health of populations.

At age 25, Americans in the highest income group can expect to live more than six years longer than their poor counterparts (figure 3).<sup>12</sup> The Social Security Administration reports that retirees at age 65 are living longer, but since the 1970s those with earnings in the top half of the income distribution have seen their life expectancy increase by more (6.0 years) than those in the bottom half (1.3 years). These income-based differences in life expectancy can also be seen across communities. For example, Virginia's Fairfax County, one of the richest counties in the country, and West Virginia's McDowell County, one of the poorest, are separated by just 350 miles; however, the difference in life expectancy between the two counties is vast. In Fairfax, "men have an average life expectancy of 82 years and women, 85, about the same as in Sweden." By contrast, the average male and female estimates for life expectancy in McDowell County are 64 and 73 years, respectively, about the same as in Iraq (Wolfe et al, 2015).

**Table 1. Prevalence of Diseases, by Income, 2011 (percent of adults)**

DISEASE OR ILLNESS	ANNUAL FAMILY INCOME				
	Less than \$35,000	\$35,000- 49,999	\$50,000- 74,999	\$75,000- 99,999	\$100,000 or more
Coronary heart disease	8.1	6.5	6.3	5.3	4.9
Stroke	3.9	2.5	2.3	1.8	1.6
Emphysema	3.2	2.5	1.4	1.0	0.8
Chronic bronchitis	6.3	4.0	4.4	2.2	2.4
Diabetes	11.0	10.4	8.3	5.6	5.9
Ulcers	8.7	6.7	6.5	4.7	4.4
Kidney disease	3.0	1.9	1.3	0.9	0.9
Liver disease	2.0	1.6	1.0	0.6	0.7
Chronic arthritis	33.4	30.3	27.9	27.4	24.4
Hearing trouble	17.2	16.0	16.0	16.2	12.4
Vision trouble	12.7	9.8	7.5	5.7	6.6
No teeth	11.6	7.8	5.5	4.2	4.1

Source: J. S., Schiller, J. W. Lucas, and J. A. Peregoy, "Summary Health Statistics for U.S. Adults: National Health Interview Survey, 2011." *Vital and Health Statistics* 10, no. 256 (2012): 1–207, tables 1, 4, 8, and 12. [http://www.cdc.gov/nchs/data/series/sr\\_10/sr10\\_256.pdf](http://www.cdc.gov/nchs/data/series/sr_10/sr10_256.pdf).

People with higher incomes are more likely to experience health benefits based on where they live. The health of individuals and communities is positively influenced by the conditions and assets in their living environment. Ellen and Turner (1997) identified six ways in which locality conditions can influence the health of individuals: (1) quality of local services, (2) socialization, (3) peer influences, (4) social networks, (5) exposure to crime and violence, and (6) physical distance and isolation.

Low-income communities and areas of concentrated poverty are more likely to expose their residents to higher rates of unemployment, crime, adolescent delinquency, social and physical disorder, and residential mobility which have a negative influence on health (Wolfe et al, 2015).

An article written by Kimberly Amadeo reports that the most affluent 1% of Americans live 15 years longer than the poorest 1%. The gap for women was 10 years which is the number of

years smoking shortens life expectancy. Low-income people have three times the problems with the activities of daily living than affluent adults. U.S. health care inequality was ranked 32 among rich and middle-income countries with only Chile and Portugal having a wider gap (Amadeo, 2020).

Earnings in the top 1 percent of the income distribution grew by 31.4 percent from 2009-2012, compared to 0.4 percent for the bottom 99 percent. Many experts agree that improving the economic conditions of Americans from the poor to the middle class could improve health and help control the rising costs of health care (Wolfe et al, 2015).



Works Cited

Amadeo, Kimberly. Health Care Inequality in America. The Balance. January, 2020.  
<https://www.thebalance.com/health-care-inequality-facts-types-effect-solution-4174842>

Bloom DE, Canning D. The health and wealth of Nations. Science. 2000;287:1207-9.

Bloom DE, Canning D, Fink G. Implications of population aging for economic growth. Oxford Rev Econ Policy. 2010;26:583-61

Jamison D., Summers L, Alleyne G, Arrow K, Berkley S, Binagwaho A, Bustreo F, Evans D, Feachem R, Frenk J, Ghosh G, Goldie S, Guo Y, Gupta S, Horton R, Kruk M, Mahmoud A, Moholo L, Yamey G.; Global health 2035: a world converging within a generation. The Lancet. [https://doi.org/10.1016/S0140-6736\(13\)62105-4](https://doi.org/10.1016/S0140-6736(13)62105-4)

Marmot M., Stansfeld S., Patel C., White S., North F., Head J., Brunner E., White I., Feeney A., Smith, G. (20) Health inequalities among British civil servants: the Whitehall II study. The Lancet. Volume 337, Issue 8754, 8 June 1991, Pages 1387-1393. [https://doi.org/10.1016/0140-6736\(91\)93068-K](https://doi.org/10.1016/0140-6736(91)93068-K)

**Using AHP to Determine the Best Location for  
a Free-Standing Emergency Department**

---

**DECISION SCIENCES INSTITUTE**

**Using AHP to Determine the Best Location for a Free-Standing Emergency Department**

Ms. Laurel Mills, Mr. Joseph Mazzola, Ms. Lila Huff, Mr. Omar Saunders, Dr. Burcu Adivar,  
Dr. Jennifer Bushelle-Edghill, Dr. Bola Ekezue

Fayetteville State University  
Broadwell College of Business and Economics

**ABSTRACT**

Free-standing Emergency Departments (FSEDs) are healthcare facilities licensed by a state to provide emergency services to a community. These facilities are physically separate from a full-service hospital. While FSEDs are designated to provide the same level of access and care as a hospital-based emergency department, they are not able to provide trauma services. In this study, we utilize data mining and multi -criteria decision analysis with Analytical Hierarchy Process (AHP) to determine the best location for a Free-standing Emergency Department. The proposed methodology is demonstrated with a real business case to support the establishment of a FSED in Cumberland County, North Carolina using data from the North Carolina Healthcare Association (NCHA), Cumberland County Community Health Needs Assessments and Census data.

**KEYWORDS:** Healthcare, Free-standing Emergency Departments, Location Analysis

# **Hospitality, Recreation and Sports - Abstracts**

---

# Economic Impact of PGA TOUR Champions Event

---

Poster

---

*Dr . kristi sweeney <sup>1</sup>, Dr . E. Newton Jackson, Jr. <sup>1</sup>, Dr . Megan Possinger <sup>2</sup>*

*1. University of North Florida , 2. Winthrop University*

This study evaluated regional economic impacts of the PGA TOUR Champions tournament in Endicott, New York. The DICK'S Sporting Goods Open (DSGO) is one of the largest professional sporting events held in Central New York. DICK'S Sporting Goods, has been the title sponsor since 2007. The annual event yields significant benefits to the community including new economic output (i.e., gross revenues or sales), labor earnings, new employment and total value added .

## Methodology

Trained volunteers collected data via on-site surveys throughout the tournament. Additionally, an electronic survey was sent in the subsequent weeks following tournament to non-locals from the tournament's database.

Total of 595 usable questionnaires were collected to determine direct visitor impact. Survey results assume the estimated expenditures of such individuals included in analysis a direct result of the tournament.

Total expenditures were calculated and analyzed using the economic impact software package IMPLAN-Online. Expenditures were distinctly categorized and applicable coefficients were used in the data analysis to determine the cumulative impact of the DSGO. The overall estimate of direct visitor spending at DSGO included three factors: total attendance to tournament; percent of visitors; and the average number of days respondents attended the DSGO.

## Results

The DSGO was responsible for \$9.2 million in direct spending in the economy and generated a total of \$14.7 million in new spending in Broome County. The industries with the highest share of output impacts include the food and beverage services and hotels and motels. Additionally, the tournament and its surrounding activity generated an estimated 145 new jobs in Broome County, an added \$4.6 million in wages and business owner income. On average, survey results revealed non-residents had 3.7 people in their travel party. On average, non-resident parties planned to stay 1.4 days in Broome County and spent approximately \$596 per day (\$164 per person).

Additionally, the DSGO operated by Broome County Community Charities, Inc. (BCCC) contributed \$830,000 to local advocacy organizations during the time of study, which is estimated to contribute to 15 new jobs and approximately \$435,000 in employee compensation. Their charitable contributions are a result of partnerships with DICK'S Sporting Goods, PGA TOUR Inc., and the Champions Tour Players.

Lastly, the majority of 44 years or older (61%), 89% of all survey respondents attended the tournament on Friday. Of those attending on Friday, 72% indicated that the evening concert influenced their decision to attend, reinforcing the popularity of the retrofitted 18th green. Twenty-five percent of respondents indicated they were attending for the first time, and this was nearly equivalent to the percent of respondents who were attending for their tenth consecutive year or more. Three out of four respondents stated they were extremely likely to return to the DSGO in following years.

---

# GUILT AS HEALTH MOTIVATION IN THE INDULGENT FOOD CONSUMPTION

---

Regular Session

---

*Dr . Minseong Kim*<sup>1</sup>

1. Louisiana State University Shreveport

The study of Choi, Li, and Samper [1] focused on the “just below calorie labeling (e.g., 199 vs. 200)” effect to predict consumers’ preferences for indulgent foods. Interestingly, similar to the price context, the results of each experiment clearly indicated that consumers with a high level of health motivation are more likely to overweigh the leftmost digit of “the calorie amounts” by underestimating “the nine-ending calories” of the indulgent food. Based on the findings of the prior research, this study suggests the interaction effect between guilt and the left-digit calorie effect to predict consumers’ health motivation and choice of indulgent foods. From a theoretical perspective, if consumers high in health motivation believe that the consumption and ordering of indulgent foods has a negative effect on their body or health condition, they may be more likely to feel guilt for doing so (i.e., self-focused guilt) [2]. The “anticipated guilt” leads those consumers to attempt to recover their body and health condition by strengthening their health motivation [3].

First, this study made two versions of a new hamburger advertisement along with its calorie information (e.g., 399 vs. 400). Then, a pilot study was conducted to investigate the difference in guilt for ordering the hamburger between high and low health motivation groups. As assumed, the high group exhibited a higher level of guilty ( $M_{\text{high}} = 4.97$  vs.  $M_{\text{low}} = 3.53$ ,  $t$ -value = 4.397,  $p < 0.01$ ) for ordering the hamburger with 400 calories. After checking the differences, the main study was conducted using a scenario-based online survey. This study employed structural equation modeling with the collected data to examine the associations among variables. Based on the calorie amount manipulation, the path from anticipated guilt to health motivation became stronger under the 400 calories condition (coefficient = 0.846 [400 calories] vs. coefficient = 0.579 [399 calories]). However, the path from health motivation to perceived credibility of the calorie information became stronger under the 399 calories condition (coefficient = 0.359 [400 calories] vs. coefficient = 0.575 [399 calories]). The perceived credibility had a significant impact on consumption intention only under the 399 calories condition (coefficient = 0.359, C.R. = 2.257,  $p < 0.05$ ). This study may lead consumer behavior scholars and marketers to realize that consumers’ guilt and responses to calorie information serve as core drivers of health motivations and perceptions, which in turn results in future behavioral intentions, such as food consumption.

# Statistical factors that attribute to winning in the National Basketball Association (NBA)

---

Regular Session

---

*Mr . Ryan Dailey <sup>1</sup>, Dr . Baback Vaziri <sup>1</sup>, Dr . Scott Stevens <sup>1</sup>*

*1. James Madison University*

Teams in the National Basketball Association have a primary incentive to win games. Winning games has a significant positive economic impact for NBA teams through means such as ticket and merchandise sales. In 2018, the NBA had \$8 billion in total revenue, as well as a \$2.7 billion TV contract with major cable networks. Many factors attribute to NBA teams winning games in the regular season, including but not limited to: upper-level management, coaching staffs, player scouting, player development, matchups based on playing style, and roster assembly. This study focuses primarily on the aspect of roster assembly – namely, what key statistical factors should NBA teams use to identify the players that will best maximize their number of wins.

Teams spend ample resources on constructing a team of players that will help maximize the number of games they will win. Currently, however, many teams use traditional metrics to identify which players to add to their team, and how much to pay said players. This study uses OLS and binary logistic regression to perform analysis on newer metrics that may provide more explanatory power to what is helping teams produce wins. Metrics such as true shooting percentage (TS %) and DFS100 are examples of some of the factors used in the analysis in comparison to traditional metrics such as points per game (PPG). The research questions addressed in this study are: (1) Do NBA teams and analysts value primary and secondary leading scorers based on efficiency or volume? For primary and secondary leading scorers, does efficiency or volume have more explanatory power in determining the expected number of wins? (2) Do NBA teams and analysts value “big men” (PF/C) based on offensive or defensive performance? Does the offensive or defensive performance of a big man have more explanatory power in determining the expected number of wins?

---

# Sustainability Content Analysis of the PAC-12 Conference Athletic Department Websites

---

Poster

---

*Ms . Kelsi Schaer <sup>1</sup>, Ms . Jamee Pelcher <sup>1</sup>, Dr . Sylvia Trendafilova <sup>1</sup>*

*1. University of Tennessee (Knoxville)*

The relationship between the natural environment and the sport industry has received a significant attention over the past 10 years. Sport organizations feel obligated to assume a certain level of responsibility to reduce their negative affect on the environment (Sartore-Baldwin, McCullough, Quatman-Yates, 2016). Thus far, collegiate athletic departments' efforts and initiatives regarding sustainability have been lackluster in comparison to the Olympics and professional leagues. Despite the unique aspects that can be leveraged for branding or revenue generation, few collegiate athletic departments have seized the opportunity to go green (McSherry, 2009). Addressing environmental sustainability is a multifaceted endeavor and depends on the environmental knowledge and awareness within the organization as well as financial and human resources (McCullough & Cunningham 2011; McCullough, 2013; Natural Resources Defense Council, 2013).

The purpose of this study was to analyze each PAC-12 conference athletic department to access the environmental sustainability information communicated to stakeholders through each of the school's websites. The PAC-12 conference institutions are the only college athletic conference that hosts a yearly sustainability summit. The study was modeled after a study conducted by Stahl and Pfahl (2013) who looked at the environmental information presented on the websites in the five major professional sports leagues in North America. We utilized the same labels as Stahl and Pfahl (2013) to categorize the data. Furthermore, we analyzed the data by adopting McCullough, Pfahl, and Nguyen's (2016) concept of waves to categorize the variety of approaches to environmental sustainability by each institution.

Results were consistent with previous literature, indicating that engagement in environmental behavior falls into one of three categories - awareness, knowledge, or action (McCullough et al, 2016). Furthermore, findings revealed a nearly equal distribution of institutions across all three categories, ultimately indicating that each institution is actively addressing the environment, but the level of investment differs across members of the PAC-12. During the presentation of this research, and in addition to giving a more detailed report on the findings of the study, we will be discussing some of the challenges associated with initiating environmental programs in the sport industry and the transition between the different waves of sustainability. Environmentally focused initiatives have the potential to provide advantages financially and strategically while making a positive impact in society. The challenge is to move environmental strategy to the next level and integrate it into the core practices of sport organizations. It is crucial to remember that greening sport is not a quick fix; it is rather a process the successful outcome of which depends on the efforts and support of multiple stakeholders.

# Teaching strategic management to hospitality students

---

Regular Session

---

***Dr . Yuan Li*** <sup>1</sup>

*1. James Madison University*

Strategic management is of great importance to hospitality firms due to the highly competitive nature of the hospitality industry. To gain a competitive advantage over their competitors, hospitality firms employ a variety of strategies to help the firms survive and thrive. Given its importance, strategic management is often taught as a capstone course in many hospitality programs. The challenge facing strategic management instructors is how to motivate students to think strategically and critically and to apply knowledge gained in the classroom to real-world problems. In this paper, I discussed the advantages and disadvantages of several exercises and activities that are used in the classroom to facilitate learning for senior students.



# Value-Centric Education: Fostering Intellectual Exchanges to Enhance Learning

---

Workshop

---

***Dr. Mark Lyberger***<sup>1</sup>

*1. Kent State University*

Our experience as educators cannot, and should not, be limited to the years labeled as a college career. As faculty, we can influence our students' journey, guide and hopefully serve as an inspiration by utilizing value-centric approaches.

Holistic, value-centric education promotes a thought provoking and interactive environment that facilitates learning and helps prepare our students for the inevitable challenges of real-life decision making (Cavazos, 2002; Iyer, 2013). Value-centric teaching is about creating a memorable learning environment that is attractive, meaningful and relevant. It is modeled on a philosophy of "shared learning," where students and others are invited to be partners in an educational journey. It is shaped by values, situations, experiences, and exchanges. The inspirational value-centric educator is one who awakens the hunger for knowledge, understanding, learning, and growth and opens the floodgates of curiosity to create a memorable learning environment that is attractive, and meaningful. The inculcation of values (i.e. truth, integrity, right action, love, non-violence...) is by no means a simple matter.

The problems we face are often societal and materialistic in nature. There is a need to develop sound preservation and sustainability practices, incite institutional change, and promote new ways of thinking about how academic work might be done in the coming years (Fitzpatrick, 2009; Spiro, 2015). Modern educationalists are of the opinion that values are caught as well as taught. A teaching philosophy that encompasses a strategic value-oriented approach integrates practical and translatable experiences.

Educators should inquire to define what students' value. The goal is to engage students in a way that builds their sense of inquiry and enhances their thirst for life-long learning. Solving such problems is not simple, but an important first step may be the articulation of value-centric measures that can be used as a foundation to define goals, develop collaborations, foster participation, and enhance educational processes and outcomes. Value-centric learning accentuates the use of cooperation, communication, discernment, foresight, tolerance, responsibility, respect, honesty, integrity, and humility, to name a few. It is not only dependent on teaching strategies, but it also depends on caring, sharing, defining individual needs, the adequacy of the content, and foundational values.

The purpose of this workshop is to familiarize participants with the definition, methods, and benefits of value-centric learning. Strategies will be shared that facilitate value-centric exchanges to enhance learning. The workshop will begin with a discussion of value-centric measures; followed by an overview of their uses in education. Recent research has revealed that value-centric learning is a process that is optimized through collaboration and engagement. In this interactive session, you will learn about and experience several collaborative value-centric teaching strategies appropriate for any discipline that can help students achieve deeper and more long-term learning.

# **Hospitality, Recreation and Sports - Papers**

## GUILT AS HEALTH MOTIVATION IN THE INDULGENT FOOD CONSUMPTION

Minseong Kim, College of Business, Louisiana State University Shreveport, 1 University Place, Shreveport, LA 71115, 318-797-5182, [minseong.kim@lsus.edu](mailto:minseong.kim@lsus.edu)

### ABSTRACT

The study of Choi, Li, and Samper [1] focused on the “just below calorie labeling (e.g., 199 vs. 200)” effect to predict consumers’ preferences for indulgent foods. Interestingly, similar to the price context, the results of each experiment clearly indicated that consumers with a high level of health motivation are more likely to overweigh the leftmost digit of “the calorie amounts” by underestimating “the nine-ending calories” of the indulgent food. Based on the findings of the prior research, this study suggests the interaction effect between guilt and the left-digit calorie effect to predict consumers’ health motivation and choice of indulgent foods. From a theoretical perspective, if consumers high in health motivation believe that the consumption and ordering of indulgent foods has a negative effect on their body or health condition, they may be more likely to feel guilt for doing so (i.e., self-focused guilt) [2]. The “anticipated guilt” leads those consumers to attempt to recover their body and health condition by strengthening their health motivation [3].

First, this study made two versions of a new hamburger advertisement along with its calorie information (e.g., 399 vs. 400). Then, a pilot study was conducted to investigate the difference in guilt for ordering the hamburger between high and low health motivation groups. As assumed, the high group exhibited a higher level of guilty ( $M_{\text{high}} = 4.97$  vs.  $M_{\text{low}} = 3.53$ ,  $t\text{-value} = 4.397$ ,  $p < 0.01$ ) for ordering the hamburger with 400 calories. After checking the differences, the main study was conducted using a scenario-based online survey. This study employed structural equation modeling with the collected data to examine the associations among variables. Based on the calorie amount manipulation, the path from anticipated guilt to health motivation became stronger under the 400 calories condition (coefficient = 0.846 [400 calories] vs. coefficient = 0.579 [399 calories]). However, the path from health motivation to perceived credibility of the calorie information became stronger under the 399 calories condition (coefficient = 0.359 [400 calories] vs. coefficient = 0.575 [399 calories]). The perceived credibility had a significant impact on consumption intention only under the 399 calories condition (coefficient = 0.359, C.R. = 2.257,  $p < 0.05$ ). This study may lead consumer behavior scholars and marketers to realize that consumers’ guilt and responses to calorie information serve as core drivers of health motivations and perceptions, which in turn results in future behavioral intentions, such as food consumption.

### REFERENCES

- [1] Choi, J., Li, Y.J., & Samper, A. The influence of health motivation and calorie ending on preferences for indulgent foods. *Journal of Consumer Research*, 2019, 46, 606-619.
- [2] Pounders, K.R., Moulard, J.G., & Babin, B.J. Examining customer-created guilt in a service context. *Psychology & Marketing*, 2018, 35, 830-844.
- [3] Dahl, D.W., Honea, H., & Manchanda, R.V. Three Rs of interpersonal consumer guilt: Relationship, reciprocity, reparation. *Journal of Consumer Psychology*, 2005, 15(4), 307-315.

## SUSTAINABILITY CONTENT ANALYSIS OF THE PAC-12 CONFERENCE ATHLETIC DEPARTMENT WEBSITES

Kelsi Schaer, KRSS Department, University of Tennessee, 1914 Andy Holt Ave, Knoxville, TN 37996, 503-735-5264, kschaer@vols.utk.edu

Jamee Pelcher, KRSS Department, University of Tennessee, 1914 Andy Holt Ave, Knoxville, TN 37996, 828-421-1894, jpelche1@vols.utk.edu

Sylvia Trendafilova, KRSS Department, University of Tennessee, 1914 Andy Holt Ave, Knoxville, TN 37996, 865-974-8891, sylviat@utk.edu

### Abstract

The relationship between the natural environment and the sport industry has received a significant attention over the past 10 years. Sport organizations feel obligated to assume a certain level of responsibility to reduce their negative affect on the environment (Sartore-Baldwin, McCullough, Quatman-Yates, 2016). Thus far, collegiate athletic departments' efforts and initiatives regarding sustainability have been lackluster in comparison to the Olympics and professional leagues. Despite the unique aspects that can be leveraged for branding or revenue generation, few collegiate athletic departments have seized the opportunity to go green (McSherry, 2009). Addressing environmental sustainability is a multifaceted endeavor and depends on the environmental knowledge and awareness within the organization as well as financial and human resources (McCullough & Cunningham 2011; McCullough, 2013; Natural Resources Defense Council, 2013).

The purpose of this study was to analyze each PAC-12 conference athletic department to access the environmental sustainability information communicated to stakeholders through each of the school's websites. The PAC-12 conference institutions are the only college athletic conference that hosts a yearly sustainability summit. The study was modeled after a study conducted by Stahl and Pfahl (2013) who looked at the environmental information presented on the websites in the five major professional sports leagues in North America. We utilized the same labels as Stahl and Pfahl (2013) to categorize the data. Furthermore, we analyzed the data by adopting McCullough, Pfahl, and Nguyen's (2016) concept of waves to categorize the variety of approaches to environmental sustainability by each institution.

Results were consistent with previous literature, indicating that engagement in environmental behavior falls into one of three categories - awareness, knowledge, or action (McCullough et al, 2016). Furthermore, findings revealed a nearly equal distribution of institutions across all three categories, ultimately indicating that each institution is actively addressing the environment, but

the level of investment differs across members of the PAC-12. During the presentation of this research, and in addition to giving a more detailed report on the findings of the study, we will be discussing some of the challenges associated with initiating environmental programs in the sport industry and the transition between the different waves of sustainability. Environmentally focused initiatives have the potential to provide advantages financially and strategically while making a positive impact in society. The challenge is to move environmental strategy to the next level and integrate it into the core practices of sport organizations. It is crucial to remember that greening sport is not a quick fix; it is rather a process the successful outcome of which depends on the efforts and support of multiple stakeholders.

**Information Privacy,  
Security and System  
Resilience, Business  
Ethics and Business Law -  
Abstracts**

# AN ASSESSMENT OF SMARTPHONE SECURITY BEHAVIORS

---

Oral

---

***Dr . Amita Chin <sup>1</sup>, Dr . Elizabeth Jones <sup>2</sup>, Dr . Philip Little <sup>2</sup>***

*1. Virginia Commonwealth University , 2. Western Carolina University*

In 2014, it was estimated that 55% of the U.S. population owned a smartphone (<https://www.pewresearch.org/internet/fact-sheet/mobile/>); in 2019, that estimate escalated to a staggering 81% of the population. The use of mobile technologies has transformed our personal and professional lives in an unprecedented manner. The explosive growth in both the use of smartphones and in the plethora of personal data routinely deposited on them has given rise to significant security concerns. A willy-nilly consumer adherence to security protocols has incentivized hackers to target smartphones using mobile malware. A misappropriated phone can avail to the perpetrator a vast volume of personal data, calendar information, contacts, etc.

The purpose of this study is to assess changes in the security behavior of smartphone users over time. For example, as the threats to security and privacy increase, have user behaviors changed accordingly? Our initial study, which surveyed undergraduate business students in 2014, revealed a disconcerting lack of awareness or care regarding smartphone security. In December 2019, we again surveyed undergraduate business students to determine their current level of awareness and attitudes. We compare and contrast the results of the two survey administrations to present a comparative analysis between 2014 and 2019.

Topics: Smartphone security, business students, mobile devices, cell phones

## Employer-Established HSA Accounts as ERISA Plans

---

Oral

---

***Dr. Richard Barnes***<sup>1</sup>

*1. Western Governors University*

This early-stage draft studies the unintended consequences of employers electing to not classify their employee Health Savings Account offering as an ERISA covered health plan. Specifically, the article studies interpretative regulatory guidance from the Department of Labor that purports to exclude employer-sponsored Health Savings Accounts from being ERISA plans, if this guidance is consistent with the congressional intent of ERISA and the consequences of how bankruptcy courts are managing the impacts of these non-ERISA employer sponsored health/retirement plans.



---

# Examining a Unified Model of Information Security Policy Compliance

---

Oral

---

*Dr . Alex Koohang <sup>1</sup>, Dr . Joanna Palisziewicz <sup>2</sup>*

*1. Middle Georgia State University , 2. Warsaw University of Life Sciences*

Moody, Siponen, & Pahnla (2018) empirically examined and proposed a unified model of information security policy compliance (UMISPC) integrating variables from across eleven theories examined in previous research regarding information security policy compliance. The theories were neutralization theory, health belief model, the theory of reasoned action, protection motivation theory, theory of interpersonal behavior, deterrence theory and rational choice, the extended theory of protection motivation, the theory of planned behavior, the theory of self-regulation, extended parallel processing model, and control balance theory. The UMISPC included eight constructs. They are role values, habit, neutralization, threat, fear, response efficacy, reactance, and compliance intention. The purpose of this study is to examine the UMISPC using a different sample. To do this, we modified the items of the constructs to reflect the nature of our participative study. In addition, the items were slightly modified to reflect individuals' behavior as well as a uniform view in the wording of the items for each construct enhancing the validity of the instrument. We administered the instrument a sample of university faculty and staff via SurveyMonkey™. SmartPLS 3.0, a partial least square structural equation modeling software (Ringle et al., 2005) was used to analyze the collected data by first establishing the reliability of the model, i.e., indicator reliability and internal consistency. Second, the validity of the model, i.e., convergent validity and discriminant validity are established. Next, the structural model is used to evaluate the R2 values followed by results from the Path Coefficients, T-Statistics, & P-Values. We report on our preliminary findings with implications and recommendations for future research.

Keywords: Information security, policy, compliance, behavior

## References

- Moody, G. D., Siponen, M., & Pahnla, S. (2018). Toward a unified model of information security policy compliance. *MIS Quarterly*, 42(1).
- Ringle, C., Wende, S. & Will, A. (2005). *SmartPLS 3.0*. Hamburg: SmartPLS, <http://www.smartpls.de>

# **Failure is Not Final: How Fear-Induced Learning from Failure Can Bridge Dread Factor and Coping Factor in IT Security Behaviors**

---

Oral

---

*Dr . John (Chengqi) Guo <sup>1</sup>, Dr . Ping Wang <sup>1</sup>*

*1. James Madison University*

Fear is a robust psychological construct whose manifestations exert impacts on numerous streams of research. This study draws on the recent neuroscience evidence that a healthy amount of fear arousal can lead to an augmented performance in cognitive abilities and learning activities. Specifically, it investigates, through the lens afforded by the literature of learning from failures, how individuals engage with learning and coping behaviors induced by fear when they confront pervasive and imminent security risks. Taking into account research findings that examine the antecedents of drawing lessons from failed experience, this paper adopts a multistage approach to test a tri-factor model elucidating relationships among the dread factor, the learning factor, and the coping factor. Notwithstanding a preliminary conceptualization of fear-induced learning from failure in the context of behavioral information security, this study addresses theoretical gaps between fear and coping efforts that are not present in the previous studies. It also provides practical interventions that may yield better learning outcomes for those who actively deal with cyber-threats.

## POSTDECISIONAL JUDGMENTS IN INFORMATION SECURITY

---

Oral

---

***Dr . Yuan Li <sup>1</sup> , Dr . Jingguo Wang <sup>2</sup>***

*1. University of Tennessee , 2. University of Texas at Arlington*

Past research on individuals' information security behaviors has focused on primary judgments of security events (i.e., whether the events pose threat to the individuals) but overlooked the importance of postdecisional judgments of the correctness of the primary judgments. This second type of judgments, usually measured with subjective confidence, is critical as it reflects an individual's ability to monitor errors in the primary judgments and make corrections without explicit external feedback (such as the actual occurrence of the events). In this study, we draw upon the metacognitive literature to examine the underlying processes of postdecisional judgments and explore antecedents to the effectiveness of the judgments. We suggest that an extension from the primary judgments to the metacognitive, postdecisional judgments furthers our knowledge of the judgmental process of individuals in dealing with security risks. This has potentials in improving individuals' security behaviors through training or other interventions.

# SMARTPHONE SECURITY PRACTICES AMONGST BUSINESS STUDENTS

---

Oral

---

*Dr . Amita Chin<sup>1</sup>, Dr . Elizabeth Jones<sup>2</sup>, Dr . Philip Little<sup>2</sup>*

*1. Virginia Commonwealth University , 2. Western Carolina University*

In 2019, the number of smartphone users in the United States is estimated to be over 266 million, or 81% of the population. While smartphones, combined with a plethora of apps that are readily available, have become wholly integrated into our daily lives, they embody a multitude of risks for consumers. For example, most consumers use their smartphone as a repository of vast personal data, including address information, contacts, appointments, bank information, passwords, etc. While biometric security precautions such as faceID may thwart some unauthorized access, a host of additional security infractions may occur, resulting in an unsanctioned exposure of personal data.

The purpose of this study is to assess smartphone security practices. The specific research question examined in this study is: What is the current state of smartphone security awareness and practices among college business students? A survey of security-related practices was administered to students in multiple business classes at a regional public university in December 2019. A student population was chosen because this generation represents zealous adopters of smartphone technology. Survey questions were categorized as those related to ‘avoiding harmful behaviors and activities,’ ‘providing protection through phone settings and add-on utilities,’ and ‘preparing for disaster recovery.’ An analysis of the results of our survey are presented.

Topics: Smartphone security, business students, mobile devices, cell phones

# User Evaluation of a Visual Approach to Cloud Security

---

Oral

---

***Dr . Jordan Shropshire <sup>1</sup>, Dr . Ryan Benton <sup>1</sup>***

*1. University of South Alabama*

The cloud ecosystem has become an essential element in personal, enterprise, and social computing architectures. Clouds provide users with pervasive information services that scale on demand. These services are rendered by virtual machines and containers. They are critical in the delivery of scalable, low services via the cloud. If the integrity of a container or a virtual machine is doubted, the cloud is irrelevant. This study introduces a new approach to confirming the integrity of cloud-based resources. The new approach uses data visualization. The raw contents of virtual machines and containers are depicted using two dimensional, colored visualizations. Analysts can use the visualizations to detect malware and other anomalies. Earlier tests indicate it is empirically effective. But what do users think of it? A survey is conducted to assess user perceptions of the new approach. The results indicate the new approach has high relative advantage, compatibility, and observability although it rates lower in trialability and complexity.

**Information Privacy,  
Security and System  
Resilience, Business  
Ethics and Business Law -  
Papers**

## **A COMPARATIVE ASSESSMENT OF SMARTPHONE SECURITY BEHAVIORS**

Amita Goyal Chin, Department of Information Systems, Virginia Commonwealth University,  
301 W. Main Street, Richmond, VA 23284-4000, 804-828-1737, [agchin@vcu.edu](mailto:agchin@vcu.edu)

Beth H. Jones, College of Business, Western Carolina University, Cullowhee, NC 28723, 828-  
508-6371, [bjones@wcu.edu](mailto:bjones@wcu.edu)

Philip Little, College of Business, Coastal Carolina University, Conway, SC 29528, 828-200-  
9352, [plittle1949@live.com](mailto:plittle1949@live.com)

### **ABSTRACT**

In 2014, it was estimated that 55% of the U.S. population owned a smartphone (<https://www.pewresearch.org/internet/fact-sheet/mobile/>); in 2019, that estimate escalated to a staggering 81% of the population. The use of mobile technologies has transformed our personal and professional lives in an unprecedented manner. The explosive growth in both the use of smartphones and in the plethora of personal data routinely deposited on them has given rise to significant security concerns. A willy-nilly consumer adherence to security protocols has incentivized hackers to target smartphones using mobile malware. A misappropriated phone can avail to the perpetrator a vast volume of personal data, calendar information, contacts, etc.

The purpose of this study is to assess changes in the security behavior of smartphone users over time. For example, as the threats to security and privacy increase, have user behaviors changed accordingly? Our initial study, which surveyed undergraduate business students in 2014, revealed a disconcerting lack of awareness or care regarding smartphone security. In December 2019, we again surveyed undergraduate business students to determine their current level of awareness and attitudes. We compare and contrast the results of the two survey administrations to present a comparative analysis between 2014 and 2019.

Topics: Smartphone security, business students, mobile devices, cell phones

## **Examining a Unified Model of Information Security Policy Compliance**

Alex Koohang, Middle Georgia State University, USA

Joanna Paliszkievicz, Warsaw University of Life Sciences, Poland

### **Abstract**

Moody, Siponen, & Pahnla (2018) empirically examined and proposed a unified model of information security policy compliance (UMISPC) integrating variables from across eleven theories examined in previous research regarding information security policy compliance. The theories were neutralization theory, health belief model, the theory of reasoned action, protection motivation theory, theory of interpersonal behavior, deterrence theory and rational choice, the extended theory of protection motivation, the theory of planned behavior, the theory of self-regulation, extended parallel processing model, and control balance theory. The UMISPC included eight constructs. They are role values, habit, neutralization, threat, fear, response efficacy, reactance, and compliance intention. The purpose of this study is to examine the UMISPC using a different sample. To do this, we modified the items of the constructs to reflect the nature of our participative study. In addition, the items were slightly modified to reflect individuals' behavior as well as a uniform view in the wording of the items for each construct enhancing the validity of the instrument. We administered the instrument a sample of university faculty and staff via SurveyMonkey™. SmartPLS 3.0, a partial least square structural equation modeling software (Ringle et al., 2005) was used to analyze the collected data by first establishing the reliability of the model, i.e., indicator reliability and internal consistency. Second, the validity of the model, i.e., convergent validity and discriminant validity are established. Next, the structural model is used to evaluate the R<sup>2</sup> values followed by results from the Path Coefficients, T-Statistics, & P-Values. We report on our preliminary findings with implications and recommendations for future research.

Keywords: Information security, policy, compliance, behavior

### **References**

- Moody, G. D., Siponen, M., & Pahnla, S. (2018). Toward a unified model of information security policy compliance. *MIS Quarterly*, 42(1).
- Ringle, C., Wende, S. & Will, A. (2005). *SmartPLS 3.0*. Hamburg: SmartPLS, <http://www.smartpls.de>



## **FAILURE IS NOT FINAL: HOW FEAR-INDUCED LEARNING FROM FAILURE CAN BRIDGE DREAD FACTOR AND COPING FACTOR IN IT SECURITY BEHAVIORS**

Chengqi "John" Guo and Ping Wang

College of Business, James Madison University, 421 Bluestone Dr., Harrisonburg, VA 22807

Emails: (Guo) guocx@jmu.edu and (Wang) wangpx@jmu.edu

### **ABSTRACT**

Fear is a robust psychological construct whose manifestations exert impacts on numerous streams of research. This study draws on the recent neuroscience evidence that a healthy amount of fear arousal can lead to an augmented performance in cognitive abilities and learning activities. Specifically, it investigates, through the lens afforded by the literature of learning from failures, how individuals engage with learning and coping behaviors induced by fear when they confront pervasive and imminent security risks. Taking into account research findings that examine the antecedents of drawing lessons from failed experience, this paper adopts a multistage approach to test a tri-factor model elucidating relationships among the dread factor, the learning factor, and the coping factor. Notwithstanding a preliminary conceptualization of fear-induced learning from failure in the context of behavioral information security, this study addresses theoretical gaps between fear and coping efforts that are not present in the previous studies. It also provides practical interventions that may yield better learning outcomes for those who actively deal with cyber-threats.

### **INTRODUCTION**

"Failure is simply the opportunity to begin again, this time more intelligently." - Henry Ford. From a natural selection perspective, learning from failure (LFF) is an essential skill and a practiced exercise of human beings. After millions of years, human brains have evolved and become much more than a chemical amalgam and thankfully, are prepared for learning from bad decisions. LFF is also an enduring research topic in long-existing fields, including personal psychology, organizational behavior, public administration, management, entrepreneurship, and engineering. However, such a critical behavioral trait has not received as much attention as it should in the core literature of Information Technology (IT) Security (e.g., the basket journals), especially when drawing lessons from failure constitutes a crucial aspect of various deterrent and mitigating measures in security management. For example, Security Education, Training, and Awareness (SETA) programs utilize lessons learned, both failures and successes, to foster computer users' awareness of the organization's cybersecurity well-being. By achieving more effective compliance of security policies, SETA strives for a win amongst partners, customers, and other stakeholders in the industry biospheres [1]. Moreover, incident response plans are indispensable to cybersecurity task forces and may become lethargic unless they frequently learn from previous lessons through firsthand knowledge or vicarious experience. After all, Intrusion Detection Systems (IDS) (e.g., Antivirus software) rigorously learn from precedent cases of security breaches to strengthen infrastructural cybersecurity.

The gravity of security threats these days is staggering [2]. Not only do new variants of malware keep emerging, but the past-its-prime attacks continuously find their ways, using the old backdoor, to cripple and befuddle victims. According to a threat intelligence report spanning from 2007 to 2017, organizations still get compromised by the same old tricks, the same old vulnerabilities. Although some organizations are doing all the right things and stay secure, attackers do not have to engage in rigorous and advanced reconnaissance activities because too many companies leave their apps and databases wide open for exploits, on top of straggling social engineering toolkits that coax computer users to give away credentials voluntarily [46]. This disconcerting phenomenon raises two propositions: (1) LFF has not received its due respect in practices and research, and/or (2) there is a lack of motivation to learn from failures among computer users. For example, companies who lost large quantities of customer data "can continue to make money while being protected by the sluggishness of legislative bodies" [3]. It also suggests that much remains unknown about the role of LFF as to how it serves as a theoretically explicable variable amid the existing nomological network of IT security research. To evaluate these propositions, researchers must unveil the antecedents and examine the influences of LFF in IT security and recognize that LFF represents a critical stream of research that renders remarkable implications for scholars and practitioners who actively seek intelligence and insights in cybersecurity issues.

Security and privacy research lies at the center of the information systems (IS) artifact [4]. Although there has been significant progress achieved hitherto in research that strives toward better understandings of the principles governing the operations of the minds and behaviors related to IT security [5]; [6]; [7]; [8]; [9]; [10]; [11]; [12]; [13]; [2], LFF remains unexplored. Whereas in many other disciplines, the conceptualization and empirical works of LFF, which serves either as an exogenous or endogenous variable, exhibit a high level of complexity and variety. Hence, in order to shed light on the fundamental dynamics of LFF process in the context of IT security, one must draw upon the theories from other areas and take into several theoretical considerations. This study, therefore, initiates this momentum by evaluating the bridging role of fear-induced LFF between the dread factor and the coping factor. Fear is a robust psychological construct whose manifestations exert impacts on core variables discussed in IT security literature (e.g., protection motivation). However, little research has managed to elucidate the effects of fear arousal on learning from security breaches or failures. In the light of this gap, this study conceives a research framework based on [7] where the dread factor (fear triggered by perceived threat) acts as fear arousal spurring the coping factor (perceived avoidability and coping behavior) through the LFF bridge factor.

This paper brings forth many contributions. First, it challenges the conventional wisdom of fear arousal being a widely accepted negative distraction in learning activities by leveraging neuroscience findings (e.g., [14]; [15]; [16] to study behavioral security phenomena, thereby suggesting that the presence of moderate fear stimuli may augment learning performance and thus positively affect security coping behavior of end users. Second, it expands the current nomological network of understandings about behavioral IT security studies. Before this study, a preponderance of intervention studies focus on the evaluation of factors, such as problem-based and emotion-based coping [8]; [11]; [2], when

threats confront acting agents without considering the influence of prior failure experience, which ubiquitously exists amongst IT security practices. Third, it reveals hidden connections between LFF and other constructs such as fear, whose effects are rigorously investigated by leading IT security scholars. Finally, this study represents a cross-paradigm endeavor through which three genetically distinctive disciplines meet and inform each other: organizational behavior, behavioral IT security, and neuroscience, resonating with [17] on the movement of blending IS research traditions.

There are a couple of caveats when investigating IT security issues through the lens of fear-induced LFF. First, although learning from experience embraces both failures and successes, this study focuses on learning from failure instead of success because: (1) previous studies have established that failures are more effective motivators than successes for drawing lessons from the past [18]; [19]; [20]. In the industry, organizations demonstrate stronger inclination to take actions, implement recommendations, and enact codes of conducts when negative results are present [20]; (2) IT security personnel are trained to handle negative consequences - data leak, zero-day vulnerability, Denial of Service (DoS), and many others. The entire cybersecurity industry encompasses the notion of being prepared for undesirable outcomes to "protect computers, networks, programs, and data from unauthorized and unintended access" [52]. Second, scholars have studied LFF mostly at the organizational level in the past. To circumvent this obstacle, one must carefully examine and administrate the construct validity issue relating to the measures drawn from classic works. Fortunately, research in entrepreneurship and management offers some successful examples of individual-level analysis of LFF (e.g., [20]. Besides, [21] provide useful techniques to adjust and recontextualize external construct measurement in behavioral studies.

### **THEORETICAL BACKGROUND: LFF AND FEAR-INDUCED FUNCTIONS**

Early works in organizational behavior and managerial psychology have explored LFF as a means calling for managers to increase their capacity to cope with crisis events by learning from the experience of previous crises. Further, empirical research has shown that organizations learn more effectively from failures than successes, that knowledge from failure depreciates more slowly than knowledge from success, and that prior experience associated with failure influences how effectively organizations can learn from various forms of negative consequences [22].

Entrepreneurship literature provides in-depth coverage on rich experience vis-à-vis the process and consequences of business failure of entrepreneurs at the individual level [23]. As to team-based LFF behaviors, [24] examined a complex pathway through which CEOs, who exhibit relational leadership, may improve the quality of strategic decisions of their top management teams by creating psychological conditions of trust and facilitating learning from failures in their teams. Being a cross-level unit of analysis, LFF is also versatile in serving as an exogenous, endogenous, or mediating construct appeared in original works (e.g., [25]; [22]; [20]; [24]; [26]; [27]; [28]. Edmonson sheds light on the long-term strategic options for organizations to learn better from failures, whereas [20] focus on the immediate feedback about what goes wrong after each training day for

military personnel to improve their field performance. A literature review indicates that the extant body of knowledge has developed reasonably extensive exposure of LFF in multiple dimensions and areas.

Fear-induced functions, widely studied by psychologists, anthropologists, and zoologists, yield a broad range of products ranging from anxiety, aggression [29]; [30]; [31], depression [32], violence [29]; [31], and learning behaviors [33]; [43]; [34] found in both humans and animals (e.g., fear conditioning on rodents and felines). For example, a study by the Cornell Feline Health Center suggests that any type of physical punishment can increase a cat's fear and worsen aggression [44]. On the learning side, the seminal work of [33] studies fear, as an acquirable drive among Albino rats, in the learning of new responses. In his experiments, the animals exhibited trial-and-error (a failure-based learning technique) behavior and gradually learned how to escape from the compartment by mastering the operation of a specific apparatus - the rotating wheel. Miller further demonstrates that the learning behavior persists if the rotating wheel was replaced with a pressing bar, and the animals acquired a new response provided with the application of electric shocks that are delegated to represent failures. These findings further attest that the learning of the new habits was dependent upon having received electric shocks during the training. Moreover, Miller extended his studies to the human realm and argued that "an important role in human behavior is played by drives, such as fears, or desires for money, approval, or status..." [33] p.1), calling for more work in the vein of fear-induced learning. Burke et al. [43] echo Miller's research and discover that the construct of dread concerning hazard exposures (e.g., fires and explosions) plays a critical role in the enhancement the experiential learning.

Interestingly, the experimental evidence found in [33], and those of his and followers' continuous studies, is paralleled with many empirical and/or clinical observations which indicate that fear plays a leading role in the production of conscious behavior. These observations and findings include the Protection Motivation Theory (PMT) in healthcare [35]; Rogers and Prentice-Dunn [54] and the research on motivating computer users to engage in more secure habits [7]. The former focuses on the articulation and manipulation of fear appeal to engage in a particular health-improving action (e.g., drink less mountain dew), while the latter applies PMT in the information security and privacy context (e.g., one should back up data more often). There is a noticeable gap; however, existing between fear and the desired action outcome. In other words, LFF, once aroused by fear, can enhance the saliency of perceived efficacy of agent or response so that the impetus of safeguarding IT security might be debilitated.

### **RESEARCH MODEL AND HYPOTHESES**

To fully understand the locus of fear-induced LFF in the context of IT security research, this study developed a research model based on the full nomologies of PMT, organizational learning models, and conceptualizations of IT security research [7]; [8]; [12]; [22]. In Figure 1, a tri-factor network is present: the dread factor, the bridge factor, and the coping factor. The dread factor represents the primary appraisal [2] and contains perceived threat severity and perceived threat vulnerability or susceptibility. The bridge factor consists of

LFF, derived from organizational learning theories, psychological safety, a direct antecedent of LFF, and high-quality relationships, an indirect antecedent of LFF. The coping factor comprises of perceived avoidability, another composite construct that depicts "users' assessment of the likelihood they will be able to avoid the IT security threat facing them by using available safeguarding measures [2] p. 379, and the construct of Volitional Coping Behavior (VCB) representing user's behavior of coping with cyber-threats. When computer users confront external stimuli that are of an ominous nature, that is, they perceive a virus infection, malware infestation, or unauthorized access, the coping factor is engaged and starts assessing the response cost, plus the efficacy of agent and response. The outcome of dread factor assessment indirectly influences the coping assessment through the bridge factor, whose intermediary effect is dependent upon the strength of dread factor assessment that could arouse various levels of LFF experience. The VCB is defined as the dependent variable in this model because the extinguishment of perceived threat severity and vulnerability will not take place unless VCB transpires [36]. The assessment of self-efficacy, response efficacy, and response cost will find VCB as their sole outlet.

To illustrate the comparison, Figure 2 presents the core and full nomologies of PMT as the base model [7]. The perceived threat severity and vulnerability induce anxiety and stress, which are closely related to the element of fear, as users are thinking of a harmful cyber-attack. A healthy dose of the negative distractor such as fear arousal can be associated with better task-relevant performance as the acting agent attempts to draw on previous experience, especially failed ones [22]; [16]. It follows that the subsequent lessons learned could lead to more effective use of coping behavior - VCB.

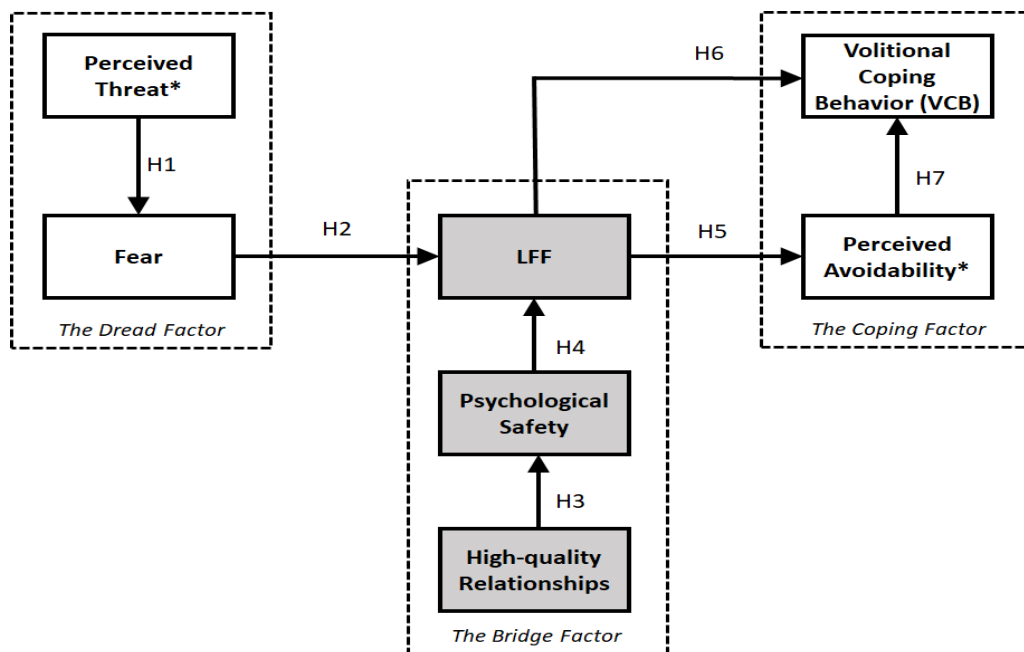

Figure 1. Research Model

\* Following [2], this study employs Perceived Avoidability and Perceived Threat as composite constructs.

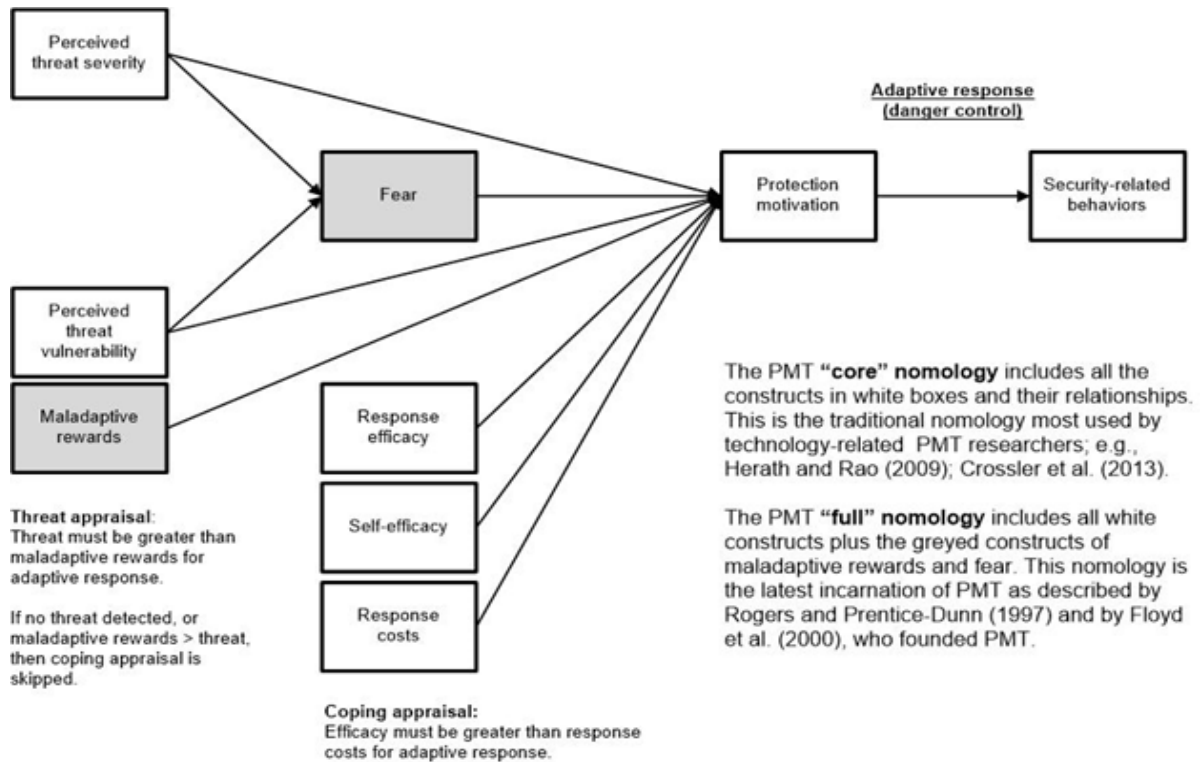

Figure 2. The Base Model: An Overview of the Core and Full Nomology of PMT [7], p. 840)

### ***The Dread Factor***

There is a plethora of research that investigates fear arousal as a universally negative distraction or emotion (e.g., [37], and IT security literature is no exception (e.g., [7]. [37] defines fear as a negatively valenced emotion that is elicited by a perceived threat, which is also seen to be significant and relevant, and that results in a heightened sense of arousal. However, recent studies indicate that low-arousal negative distractors were associated with better task-relevant performance than were positive and neutral distractors [16]. Also, research shows findings at physiological and cognitive levels that the presence of fear arousal increases sensory exposure [15], and processing fear on others faces modifies attentional processing [14]. Therefore, it is possible for fear to positively affect cognitive performance - an essential part of learning, according to the evidence found on the neurobiological basis. Based on these discoveries, the following hypotheses propose that:

*H1: Perceived threat will be positively associated with fear.*

*H2: Fear will be positively associated with LFF.*

### ***The Bridge Factor & Coping Factor***

Tucker and Edmondson [56] conceptualize failure in the organizational learning context as "a disruption that prevents the completion of an organizational task or achieving a desired organizational end" [25] p. 711). This study hence draws upon this definition and defines

an IT security failure as a threat stemming from the unpredictable and undesirable outcome of a system to meet IT security requirements (for example, unauthorized data intrusion). It further extends the argument by linking the capacity to learn from past IT security failures (LFF), entailing a willingness to detect resemblances between past and current situations [57], with a healthy amount of fear emotion. According to Burke et al. [43], the exposure to high severity of hazardous event conditions leads to more effective hands-on training than low severity of hazardous event does, suggesting a strong correlation between dangerous external stimuli and experiential learning performance that is highly engaging, a common trait shared by IT security tasks.

Moreover, empirical works show two antecedents of LFF - psychological safety (PS) and high-quality relationships (HR)[25]. PS serves as a direct antecedent while HR works as an indirect antecedent of LFF through PS. As a documented enabler of PS, HR is critical to the establishment of an environment where fundamental attribution biases are reduced, and people are more willing to discuss their mistakes without being concerned that they will be blamed [45]. Later, Edmon (2004) pointed out that trust and perceived organizational support as enablers of psychological safety at work. In the IT security industry, threats are ubiquitous and malignant. A breach will take place some point in the future, and it could happen to anyone in the organization. Given such a large scale and perennial challenge, it is vital to create an organizational culture designed for managing failures. A key question about LFF is how it is enabled [56]. PS refers to a belief that one can express his or her self "without concerns of negative consequences to self-image, status, or career" and is found to be an essential enabler of learning behaviors in work settings [45]. [25] further argue that PS is distinct from related social or interpersonal constructs such as trust and perceived organizational support, exerting attributional impacts on the formation of learning behavior including those drawing upon past failures. Thus, the following hypotheses suggest that:

*H3: High-quality relationships will be positively associated with psychological safety.*

*H4: Psychological safety will be positively associated with LFF.*

Literature from educational psychology, entrepreneurship, and computer science has repetitively argued that self-efficacy beliefs are shaped by interpretation and reflection of previous experience and success [38], probably more so by failure than success due to the slower depreciation process of failure knowledge than that of success [22]; Burke et al. [43]. However, it is also noted that the findings relating to failure experience are mixed in that some reports suggest self-efficacy is impaired, rather than improved, by adverse outcomes (e.g., [39]. To shed light on this contradiction, this study contains a distinction in the research design where HR and PS ensure that users are exposed to an organizational culture where failures are dealt with in a healthy manner, which will not put someone in a disconcerting psychological condition. On the other hand, the opposite can be found in the previous studies where peer-pressure and judgment are present and negatively associated with self-efficacy beliefs (e.g., [40].

LFF influences dependent variables in multiple empirical studies. [22] documented that prior organizational failure, derived from both firsthand and vicarious experience, has a

direct impact on the outcome of learning behavior, showing strong evidence that organizations learn by observing their own and others' failure. [28] investigated the interplay of shared beliefs in supportive work contexts and learning from failure, the latter of which has a direct influence on group performance. Their findings also resonate with the consideration of associations among HR, PS, and LFF (H3 & H4).

Following [2], this study combines self-efficacy, response efficacy, and response into perceived avoidability, which in turn receives effects from LFF and exerts impacts on VCB. Hence, the following hypotheses suggest that:

*H5: LFF will be positively associated with perceived avoidability.*

*H6: LFF will be positively associated with VCB.*

*H7: Perceived avoidability will be positively associated with VCB.*

## RESEARCH METHOD

IS researchers are now increasingly combining in novel ways the informing theoretical perspectives and the methods that they use to conceive and execute their work [17]. This study, therefore, adopts a multistage and multimethod approach that consists of an expert panel, interview, behavioral experiments, and field survey to generate mutual-validating and complementary findings.

Given that LFF has not received much attention from the domain of IT security, proper re-contextualization must be in place. First, an expert panel will evaluate items adopted from the previous seminal works - Tucker & Edmondson [56] - to see if they demonstrate a proper amount of relevancy and goodness of fit. The experts will also address the cross-level migration of measures and make recommendations to add, remove, and modify items that are suitable for individual-level analysis of LFF behavior. The process will continue with multiple experts from both academic and industrial backgrounds. Students (must be seniors and have taken cybersecurity electives) and recently graduated alum (must work in cybersecurity capacity) are also included to provide their point of view as to whether these items can effectively elicit information. Second, a behavioral experiment of 2x2 between-subject factorial design will allow the study to reveal potential relationships endorsed by prior theories or unknown before. The dimensions are high/low threat severity/vulnerability and high/low failure experience in that we can measure their response to the constructs in all three factors except for the VCB. Third, a field survey will collect people's perceptions of all three factors (dread, bridge, and coping) to test the research model in terms of generalizability.

[41] advocate multimethod research out of three purposes: expansion, corroboration, and compensation. In this study, a field survey instrument is conceived and distributed to collect psychometric data that generate analysis results encompassing a broad range of relationships among variables and their manifestations, expanding the scope of the investigation to include both antecedents and consequence of LFF or the bridge factor. The instrument and the experiment can use their results to inform and corroborate each other.



Lastly, the vastly distinctive idiosyncrasies of behavioral experiment and field survey allow them to compensate for their tacit limitations.

### ***Measures***

The measures used in the field survey will come from the following sources: previous literature (e.g., [25]; [28];[56]), expert panel, and pre-testing. There are numerous studies in non-IS areas conducting an individual-level analysis of LFF behavior. However, most of them remain at the conceptualization level with a limited number of established measures. Even for those who do conduct empirical analysis, the measures are vaguely defined or delegated to some proxy measures. For example, Shperd captured the extent of learning by using a "then" measure, which is a retrospective self-report of one's competency before the delivery of the new course content that is collected after course delivery (at the time of the post-test). [22] used archival data of failed rocket launch to measure LFF. Therefore, the study will draw upon [21] recommended steps when selecting instruments to generate localized measures for IT security context, and then elicit feedback from experts, conduct pre-testing in experiments. The study will use deductive reasoning and feedback of interviews to decide the inclusion and exclusion of certain items. Furthermore, [42] recommend running a Q-sort to purify and validate the cross-contextual items.

## **DISCUSSION AND FUTURE RESEARCH**

Despite its strong relevance and critical role in real-world practices among millions of information workers, fear-induced LFF is an unexplored area in IT security behavior research. The current IT security literature has developed a wealth of studies utilizing a variety of informing theoretical lenses [12]. This study, therefore, contributes to the knowledge accretion by bridging a gap in a widely accepted framework and aims to enhance the outcome of volitional security behavior that is essential to the alignment of cyber actions of end users and the desired posture of management within organizations.

There are major contributions afforded by this study. First, it challenges the assumptions that fear emotion, commonly deemed as a distraction, must be minimized for augmented learning performance such as reliability and concentration. This study contends that, with a moderated amount of fear emotion, the fear-induced LFF will positively affect information workers' security behavior (e.g., scan virus more often). Second, this study fills the void where a shortage of empirical works on fear-induced LFF are present at the individual level of analysis in both IS and non-IS disciplines. Third, this study responds to [17] by blending behavioral IS and organizational IS traditions through cross-paradigm combinative practices. Specifically, the study redefines the boundary conditions of organizational learning paradigm by extending its theoretical assumptions to IT security domain. Meanwhile, the study utilizes behavioral security conceptualizations and research methods to observe, analyze, and interpret organizational learning behavior, its antecedents, and consequences in novel ways. On the practice side, managers should realize the importance of nurturing a healthy organizational culture where attributional criticism should be reduced to the minimum while open sharing of failures should be bolstered and documented, as psychological safety is a crucial and positive enabler of fear-

induced LFF. In the meantime, managers should adjust the volume of fear stimuli to a reasonable level that is effective enough to arouse mental alertness in the workspace, but not too strong to discourage and impede end users' proactive security coping behavior. Lastly, highly engaging hands-on training is an indispensable asset for information workers to be better prepared for unpredictable threats. Within the normal range of fear stimuli, there is a positive correlation between the intensity of hands-on training and LFF performance. In other words, when fear emotion is present, higher intensity training yields better results than lower intensity training.

There are also new directions along the line of this study. The interplay of LFF and learning from success (LFS), although received much attention in organizational behaviors, might exhibit unique traits and counter-intuitive characteristics when studying individual security behaviors. The effect strength of LFF on self-efficacy varies over time. Some research proposes that the later the failure occurs, the less power it has on an individual's self-efficacy. However, this phenomenon remains unstudied in IT security. It would be interesting to see future research to investigate whether and how cognitive learning theory can enhance our understandings of LFF. Another noteworthy issue is correlated failures (e.g., the 2018 Facebook data leak associated with Cambridge Analytica) that require cross-boundary LFF to engage because the widespread adoption of a single standard solution (e.g., an email application) might increase information security risks in some contexts.

#### REFERENCES

- [1] Tipton SJ, Choi YB. The Rise in Payment System Breaches: The Target Case. In: Choi YB, editor. *Sel. Readings Cybersecurity*, Cambridge Scholars Publishing; 2018, p. 46–56.
- [2] Liang H, Xue Y, Pinsonneault A. WHAT USERS DO BESIDES PROBLEM-FOCUSED COPING WHEN FACING IT SECURITY THREATS: AN EMOTION-FOCUSED COPING PERSPECTIVE Appendix A Summary of Past IT Security Research on PFC and EFC. vol. 43. 2019.
- [3] Malik O. Why Companies Won't Learn From the T-Mobile/Experian Hack |. *New Yorker* 2015. <https://www.newyorker.com/business/currency/why-companies-wont-learn-from-the-t-mobileexperian-hack> (accessed April 8, 2020).
- [4] Lowry PB, Dinev T, Willison R. Why security and privacy research lies at the centre of the information systems (IS) artefact: Proposing a bold research agenda. *Eur J Inf Syst* 2017;26:546–63. doi:10.1057/s41303-017-0066-x.
- [5] D'Arcy J, Hovav A, Galletta D. User awareness of security countermeasures and its impact on information systems misuse: A deterrence approach. *Inf Syst Res* 2009;20:79–98. doi:10.1287/isre.1070.0160.
- [6] Crossler R, Bélanger F. An extended perspective on individual security behaviors: Protection motivation theory and a unified security practices (USP) instrument. *Data Base Adv Inf Syst* 2014;45:51–71. doi:10.1145/2691517.2691521.
- [7] Boss SR, Galletta D, Lowry PB, Moody GD. What do users have to fear? Using fear appeals to engender threats and fear that motivate protective security behaviors. *MIS Q* 2015;39:837–864. doi:10.25300/MISQ/2015/39.4.5.
- [8] Johnston AC, Warkentin M. Fear appeals and information security behaviors: An

- empirical study. *MIS Q* 2010;34:549–66. doi:10.2307/25750691.
- [9] Johnston A, Warkentin M, Siponen M. An enhanced fear appeal rhetorical framework: Leveraging threats to the human asset through sanctioning rhetoric. *MIS Q* 2015;39:113-A7.
- [10] Anderson BB, Vance A, Kirwan CB, Eargle D, Jenkins JL. How users perceive and respond to security messages: A NeuroIS research agenda and empirical study. *Eur J Inf Syst* 2016;25:364–90. doi:10.1057/ejis.2015.21.
- [11] Liang H, Xue Y. Avoidance of information technology threats: A theoretical perspective. *MIS Q Manag Inf Syst* 2009;33:71–90. doi:10.2307/20650279.
- [12] Moody G, Siponen M, Pahnla S. Toward a unified model of information security policy compliance. *MIS Q* 2018;42:285-A22.
- [13] Burns AJ, Roberts TL, Posey C, Lowry PB. The adaptive roles of positive and negative emotions in organizational insiders' security-based precaution taking. *Inf Syst Res* 2019;30:1228–47. doi:10.1287/isre.2019.0860.
- [14] Vermeulen N, Godefroid J, Mermillod M. Emotional modulation of attention: Fear increases but disgust reduces the attentional blink. *PLoS One* 2009;4. doi:10.1371/journal.pone.0007924.
- [15] Susskind JM, Lee DH, Cusi A, Feiman R, Grabski W, Anderson AK. Expressing fear enhances sensory acquisition. *Nat Neurosci* 2008;11:843–50. doi:10.1038/nn.2138.
- [16] Sussman TJ, Heller W, Miller GA, Mohanty A. Emotional distractors can enhance attention. *Psychol Sci* 2013;24:2322–8. doi:10.1177/0956797613492774.
- [17] Rai A. Editor's comments: The first few pages. *MIS Q* 2018;42.
- [18] Sitkin, B. S. Learning Through Failure : The Strategy of Small Losses. *Res Organ Behav* 1992;14:231–66.
- [19] Weiner B. An attributional theory of achievement motivation and emotion. *Psychol Rev* 1985;92:548–73. doi:10.1037/0033-295X.92.4.548.
- [20] Ellis S, Davidi I. After-event reviews: Drawing lessons from successful and failed experience. *J Appl Psychol* 2005;90:857–71. doi:10.1037/0021-9010.90.5.857.
- [21] MacKenzie S, Podsakoff P, Podsakoff N. Construct measurement and validation procedures in MIS and behavioral research: Integrating new and existing techniques. *MIS Q* 2011;35:293–334.
- [22] Madsen PM, Desai V. Failing to learn? the effects of failure and success on organizational learning in the global orbital launch vehicle industry. *Acad Manag J* 2010;53:451–76. doi:10.5465/amj.2010.51467631.
- [23] Ucbasaran D, Shepherd DA, Lockett A, Lyon SJ. Life After Business Failure: The Process and Consequences of Business Failure for Entrepreneurs. *J Manage* 2013;39:163–202. doi:10.1177/0149206312457823.
- [24] Carmeli A, Tishler A, Edmondson AC. CEO relational leadership and strategic decision quality in top management teams: The role of team trust and learning from failure. *Strateg Organ* 2012;10:31–54. doi:10.1177/1476127011434797.
- [25] Carmeli A, Gittell JH. High-quality relationships, psychological safety, and learning from failures in work organizations. *J Organ Behav* 2009;30:709–29. doi:10.1002/job.565.
- [26] Carmeli A, Sheaffer Z. How Learning Leadership and Organizational Learning from Failures Enhance Perceived Organizational Capacity to Adapt to the Task Environment. *J Appl Behav Sci* 2008;44:468–89. doi:10.1177/0021886308323822.

- [27] Muehlfeld K, Rao Sahib P, Van Witteloostuijn A. A contextual theory of organizational learning from failures and successes: A study of acquisition completion in the global newspaper industry, 1981-2008. *Strateg Manag J* 2012;33:938–64. doi:10.1002/smj.1954.
- [28] Cannon MD, Edmondson AC. Confronting failure: antecedents and consequences of shared beliefs about failure in organizational work groups. *J Organ Behav* 2001;22:161–77. doi:10.1002/job.85.
- [29] Mifune N, Simunovic D, Yamagishi T. Intergroup Biases in Fear-induced Aggression. *Front Psychol* 2017;8:49. doi:10.3389/fpsyg.2017.00049.
- [30] Ilchibaeva T V., Kondaurova EM, Tsybko AS, Kozhemyakina R V., Popova NK, Naumenko VS. Brain-derived neurotrophic factor (BDNF) and its precursor (proBDNF) in genetically defined fear-induced aggression. *Behav Brain Res* 2015;290:45–50. doi:10.1016/j.bbr.2015.04.041.
- [31] Vitiello B, Stoff DM. Subtypes of aggression and their relevance to child psychiatry. *J Am Acad Child Adolesc Psychiatry* 1997;36:307–15. doi:10.1097/00004583-199703000-00008.
- [32] Huang W, Heffernan ME, Li Z, Zhang N, Overstreet DH, King JA. Fear induced neuronal alterations in a genetic model of depression: An fMRI study on awake animals. *Neurosci Lett* 2011;489:74–8. doi:10.1016/j.neulet.2010.11.069.
- [33] Miller NE. Studies of fear as an acquirable drive: I. Fear as motivation and fear-reduction as reinforcement in the learning of new responses. *J Exp Psychol* 1948;38:89–101. doi:10.1037/h0058455.
- [34] Busato V V., Prins FJ, Elshout JJ, Hamaker C. Intellectual ability, learning style, personality, achievement motivation and academic success of psychology students in higher education. *Pers Individ Dif* 2000;29:1057–68. doi:10.1016/S0191-8869(99)00253-6.
- [35] Floyd DL, Prentice-Dunn S, Rogers RW. A Meta-Analysis of Research on Protection Motivation Theory. *J Appl Soc Psychol* 2000;30:407–29. doi:10.1111/j.1559-1816.2000.tb02323.x.
- [36] Rippetoe PA, Rogers RW. Effects of Components of Protection-Motivation Theory on Adaptive and Maladaptive Coping With a Health Threat. *J Pers Soc Psychol* 1987;52:596–604. doi:10.1037/0022-3514.52.3.596.
- [37] Witte K. Putting the fear back into fear appeals: The extended parallel process model. *Commun Monogr* 1992;59:329–49. doi:10.1080/03637759209376276.
- [38] Shea P, Bidjerano T. Learning presence: Towards a theory of self-efficacy, self-regulation, and the development of a communities of inquiry in online and blended learning environments. *Comput Educ* 2010;55:1721–31. doi:10.1016/j.compedu.2010.07.017.
- [39] Lyman RD, Prentice-Dunn S, Wilson DR, Bonfilio SA. The effect of success or failure on self-efficacy and task persistence of conduct-disordered children. *Psychol Sch* 1984;21:516–9. doi:10.1002/1520-6807(198410)21:4<516::AID-PITS2310210419>3.0.CO;2-O.
- [40] Kiran-Esen B. Analyzing peer pressure and self-efficacy expectations among adolescents. *Soc Behav Pers* 2012;40:1301–10. doi:10.2224/sbp.2012.40.8.1301.
- [41] Venkatesh V, Brown SA, Bala H. Bridging the Qualitative-Quantitative Divide: Guidelines for Conducting Mixed Methods Research in Information Systems. *MIS Q*

- 2013;37:21–54. doi:10.2307/43825936.
- [42] Moore GC, Benbasat I. Development of an instrument to measure the perceptions of adopting an information technology innovation. *Inf Syst Res* 1991;2:192–222. doi:10.1287/isre.2.3.192.
- [43] Burke, M. J., Salvador, R. O., Smith-Crowe, K., Chan-Serafin, S., Smith, A., & Sonesh, S. (2011). The Dread Factor: How Hazards and Safety Training Influence Learning and Performance. *Journal of Applied Psychology*, 96(1), 46–70. <https://doi.org/10.1037/a0021838>
- [44] Cornell Feline Health Center (2016). “Feline Behavior Problems: Aggression,” Cornell University College of Veterinary Science, accessed in June 2019: <https://www.vet.cornell.edu/departments-centers-and-institutes/cornell-feline-health-center/health-information/feline-health-topics/feline-behavior-problems-aggression>
- [45] Edmondson, A. (1999). “Psychological Safety and Learning Behavior in Work Teams.” *Administrative Science Quarterly*, 44(2), 350–383. <https://doi.org/10.2307/2666999>
- [46] F5 Labs (2017). THREAT INTELLIGENCE REPORT | Lessons Learned from a Decade of Data Breaches, accessed in June 2019: [https://www.f5.com/content/dam/f5/downloads/F5\\_Labs\\_Lessons\\_Learned\\_from\\_a\\_Decade\\_of\\_Data\\_Breaches\\_rev.pdf](https://www.f5.com/content/dam/f5/downloads/F5_Labs_Lessons_Learned_from_a_Decade_of_Data_Breaches_rev.pdf)
- [52] Pendse, G. (2018). “Cybersecurity: Industry Report and Investment Case,” Nasdaq Global Information Services, accessed in June 2019: <https://business.nasdaq.com/marketinsite/2018/GIS/Cybersecurity-Industry-Report-Investment-Case.html>
- [54] Rogers, R. W., and Prentice-Dunn, S. (1997). "Protection Motivation Theory," in *Handbook of Health Behavior Research I: Personal and Social Determinants*, D. S. Gochman (ed.), New York, NY: Plenum Press.
- [56] Tucker, A. L., & Edmondson, A. C. (2003). “Why Hospitals Don’t Learn from Failures,” *California Management Review*, 45(2), 55–72. <https://doi.org/10.2307/41166165>.
- [57] Turner, B. A., & Toft, B. (2006). Organizational learning from disasters. In D. Smith, & D. Elliot (Eds.), *Key readings in crisis management: Systems and structures for prevention and recovery* (pp. 191–204). London: Routledge.

## **POSTDECISIONAL JUDGMENTS IN INFORMATION SECURITY**

Yuan Li, Haslam College of Business, University of Tennessee, 625 Stokely Management Center, Knoxville, TN 37996, 865-974-2660, yli213@utk.edu

Jingguo Wang, College of Business, University of Texas at Arlington, 701 S. West Street, Arlington, TX 76019, 817-272-3520, jwang@uta.edu

### **ABSTRACT**

Past research on individuals' information security behaviors has focused on primary judgments of security events (i.e., whether the events pose threat to the individuals) but overlooked the importance of postdecisional judgments of the correctness of the primary judgments. This second type of judgments, usually measured with subjective confidence, is critical as it reflects an individual's ability to monitor errors in the primary judgments and make corrections without explicit external feedback (such as the actual occurrence of the events). In this study, we draw upon the metacognitive literature to examine the underlying processes of postdecisional judgments and explore antecedents to the effectiveness of the judgments. We suggest that an extension from the primary judgments to the metacognitive, postdecisional judgments furthers our knowledge of the judgmental process of individuals in dealing with security risks. This has potentials in improving individuals' security behaviors through training or other interventions.

## **SMARTPHONE SECURITY PRACTICES AMONGST BUSINESS STUDENTS**

Amita Goyal Chin, Department of Information Systems, Virginia Commonwealth University,  
301 W. Main Street, Richmond, VA 23284-4000, 804-828-1737, [agchin@vcu.edu](mailto:agchin@vcu.edu)

Beth H. Jones, College of Business, Western Carolina University, Cullowhee, NC 28723, 828-  
508-6371, [bjones@wcu.edu](mailto:bjones@wcu.edu)

Philip Little, College of Business, Coastal Carolina University, Conway, SC 29528, 828-200-  
9352, [plittle1949@live.com](mailto:plittle1949@live.com)

### **ABSTRACT**

In 2019, the number of smartphone users in the United States is estimated to be over 266 million, or 81% of the population. While smartphones, combined with a plethora of apps that are readily available, have become wholly integrated into our daily lives, they embody a multitude of risks for consumers. For example, most consumers use their smartphone as a repository of vast personal data, including address information, contacts, appointments, bank information, passwords, etc. While biometric security precautions such as faceID may thwart some unauthorized access, a host of additional security infractions may occur, resulting in an unsanctioned exposure of personal data.

The purpose of this study is to assess smartphone security practices. The specific research question examined in this study is: What is the current state of smartphone security awareness and practices among college business students? A survey of security-related practices was administered to students in multiple business classes at a regional public university in December 2019. A student population was chosen because this generation represents zealous adopters of smartphone technology. Survey questions were categorized as those related to ‘avoiding harmful behaviors and activities,’ ‘providing protection through phone settings and add-on utilities,’ and ‘preparing for disaster recovery.’ An analysis of the results of our survey are presented.

Topics: Smartphone security, business students, mobile devices, cell phones

User Evaluation of a Visual Approach to Cloud Security

---

**USER EVALUATION OF A VISUAL APPROACH TO CLOUD SECURITY**

Jordan Shropshire, Professor of Information Systems, School of Computing, University of South Alabama, 150 Jaguar Drive, Suite 2101, Mobile, AL 36688, jshropshire@southalabama.edu

Ryan Benton, Assistant Professor of Computer Science, School of Computing, University of South Alabama, 150 Jaguar Drive, Suite 2101, Mobile, AL 36688, rbenton@southalabama.edu

**ABSTRACT**

The cloud ecosystem has become an essential element in personal, enterprise, and social computing architectures. Clouds provide users with pervasive information services that scale on demand. These services are rendered by virtual machines and containers. They are critical in the delivery of scalable, low services via the cloud. If the integrity of a container or a virtual machine is doubted, the cloud is irrelevant. This study introduces a new approach to confirming the integrity of cloud-based resources. The new approach uses data visualization. The raw contents of virtual machines and containers are depicted using two dimensional, colorized visualizations. Analysts can use the visualizations to detect malware and other anomalies. Earlier tests indicate it is empirically effective. But what do users think of it? A survey is conducted to assess user perceptions of the new approach. The results indicate the new approach has high relative advantage, compatibility, and observability although it rates lower in trialability and complexity.

**KEYWORDS:** Diffusion of Innovations, Information Security, Visualization, Cloud Computing

**INTRODUCTION**

The cloud ecosystem has become an essential element in personal, enterprise, and social computing architectures. Clouds provide users with pervasive information services that scale on demand. These services are rendered by containers and virtual machines. Containers and virtual machines (VMs) are isolated units which consist of applications, supporting software, and data. They are critical in the delivery of scalable, low-cost services via the cloud. If the integrity of virtual machines or containers is doubted, the cloud is irrelevant [8]. Thus, the security of containers and virtual machines is paramount.

Traditional approaches to ensuring the security of cloud-based resources includes manual inspection, in-line malware detection, and network access control. Although these approaches are well-known and widely-applicable, they have several limitations: (1) they can be detected by sophisticated malware [9], (2) they are subject to manipulation [7], (3) they are generally designed for a specific guest operating system or hypervisor [25], (4) they impact the performance of the host server, and (5) their outputted results are not easy to read or interpret [15]. Of all of these limitations, the latter is the most troubling. Users cannot respond to security alerts if they cannot interpret them.



## User Evaluation of a Visual Approach to Cloud Security

Recently, a new approach to investigating the security of containers and virtual machines was developed. This approach overcomes the shortcomings in previous methods of cloud security. It uses visualizations to depict the raw contents of VM disks and container files. The process works as follows: from a peering point within the hypervisor, the binary data associated with virtual machine disk image or container file is accessed. Byte values are passed through a privacy-preserving hash and then mapped to corresponding colors from the ASCII color table. Each byte value becomes a colored pixel in a two-dimensional, colored visualization (see Figure 1, below). For each visualization, regions are identified using techniques such as image segmentation and features describing the regions are extracted. It is possible to recognize the signs of malware within the visualization of an infected VM or container.

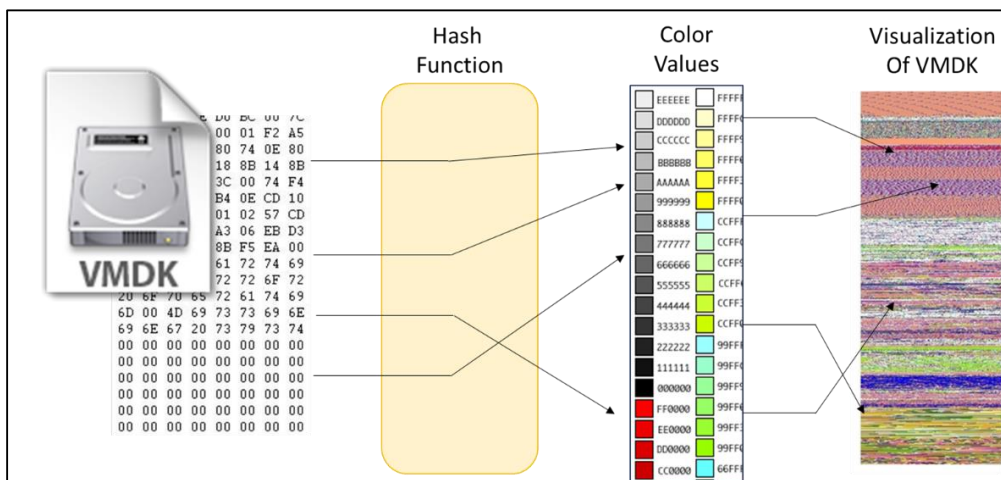

**Figure 1: Procedure for Deriving Visualizations**

This new, visual approach to cloud security was autonomously evaluated using machine learning and computer vision. The evaluation yielded a number of visual markers can be used to identify malware in cloud resources. Analysts could the proposed new approach to confirm that a suspected VM or container is compromised and should be quarantined, etc. If further developed, it would tentatively be deployed within cloud operations centers. Analysts would use the artifact to inspect suspicious VMs. It theoretically stands to provide significant value.

However, the full benefits of this approach will not be realized if potential users find it unwieldy or complex. Hence, the purpose of this study is to empirically evaluate users' perceptions of the new approach. If user views of the new approach are generally positive than development will continue as planned. However, if feedback indicate a negative overall perception than the new approach will be modified accordingly.

The perceived characteristics of the new approach are evaluated using a framework called the Perceived Attributes of Innovations. The framework was originally developed by Rogers (1983). It consists of 5 constructs: relative advantage, compatibility, complexity, trialability, and observability. A survey of potential adopters is performed in order to evaluate the artifact. The

## User Evaluation of a Visual Approach to Cloud Security

---

constructs are operationalized via a survey instrument developed by Moore and Benbasat (1991). Multivariate analysis is used to interpret potential user feedback. The results are expected to confirm the efficacy of the proposed approach.

The remainder of this paper is structured as follows: the next section is the background. It reviews cloud security and introduces the Perceived Attributes of Innovations framework. The next section describes the use of the artifact in more detail and provides hypotheses regarding user perceptions of the new approach to cloud security. The following section contains the methodology section. It describes the sample, measures, procedure, and analysis. The next section is the results. Finally, concluding comments are offered.

### **BACKGROUND**

This section provides background information on two topics. First, it discusses methods and limitations in cloud security. Next, it reviews the components in the Perceived Attributes of Innovations framework.

#### **Cloud Computing Security**

Clouds are the predominant architecture for scalable, efficient computing. Within the cloud hierarchy, the most important layer is that which contains client software and data. Hence, containers and virtual machines are a prime target for attack. They contain the applications, data, and configurations which are essential to providing high quality services. The purpose of the attack could be to create denial of service conditions within the cloud, compromise supported services, extract revenge on the associated persons or organizations, or to steal or infect hosted data [16] [26]. Virtual machines also receive extensible shares of computing resources.

After gaining control of a virtual machine, attackers may use it as a platform for installing their own software [27]. Alternatively, the target may not be the virtual machine itself but some resource within the cloud. For instance, the virtual machine could be used a springboard to launch attacks on other guests or for side-channel attacks on high-value targets. It could also become a spoke in an advanced persistent attack, reconfigured to serve as a command, communication, or control hub.

Compromised virtual machines are difficult to detect [2]. Each new generation of malware is increasingly subtle. To avoid detection, sophisticated malware will conceal itself by focusing on two areas: (1) minimizing its footprint within the operating system and (2) obstructing internal security scans. Code may be distributed between hard disk and memory in order to camouflage the installation base. Malware may also attempt to confound internal security scanners. They may time operations to only occur in the periods between security checks. They may also disable or debilitate onboard security software [3]. Some clever anti-malware programs can even detect introspection based security scans [4]. In such cases, the compromised virtual machine will give little or no indication of malfeasance.

## User Evaluation of a Visual Approach to Cloud Security

---

Most cloud security incidents are initially detected by automated monitoring tools. Because they are generally tuned to minimize the risk of false-negative errors, these tools cast a wide net of suspicion. Depending on the scale of the incident, the automated tools may implicate rather long lists of VMs and containers. Typically, these assets have to wait in quarantine until they can be forensically investigated and cleared. This could anger clients and increase operational costs for the cloud service provider. Hence, a human analyst is generally required to review log files and either clear the suspected VM / container or delete it.

The safe / compromised decision is not easy to make. It carries significant weight because it involves customer assets. Often conflicting reports make the decision harder. In practice, an unsure analyst may leave a suspected VM or container in quarantine for an extended period of time. Hence, there is a need for clear definitive proof that a VM or container is compromised. The proposed new visual approach to cloud security seeks to fulfill the need.

### **Perceived Attributes of Innovations**

The Perceived Attributes of Innovations is a framework of constructs for characterizing the relative benefits of an innovation [20]. An innovation is a new idea. It is a concept which replaces an old idea. In this case, the new innovation is a proposed new approach to assessing the integrity of cloud-based assets. The concept of perception is important. Although a new innovation could be technologically superior, give better results, provide efficiency, etc., it must first be adopted by end users [1][5]. Perceptions of potential adopters are very important. Individual impressions outweigh technological benefits when it comes to human decision making. The concept of relatively is also important. The new innovation must be compared against the status quo concept that it stands to replace. In this case, the new, visual approach to cloud security replaces traditional methods and techniques [12] [19]. Hence the potential benefits of the new approach are interpreted relative to the current techniques.

Rogers gives a list of 5 attributes of innovations to consider [21][22]. These attributes have been widely used over the past decades with consistent reaffirmation of their validity. They are sound predictors of future behavior [13]. The five attributes are: relative advantage, compatibility, complexity, observability, and trialability.

Relative advantage is the degree to which an innovation is perceived as being better than the idea it replaces. The degree of relative advantage is often expressed as economic profitability, social prestige, or other benefits. Compatibility is the degree to which an innovation is perceived as being consistent with the existing values, needs, and past experience of potential adopters. It is suggested that the compatibility of an innovation, as perceived by members of a social system, is positively related to its rate of adoption. Complexity is the degree to which an innovation is perceived as being difficult to use. The complexity of an innovation is generally found to be inversely proportional to the rate of its adoption. Observability is the degree to which the results of using an innovation are observable to others. Watching others' use of a new innovation before testing and adopting is part of the information collection which is performed prior to personal use. Trialability is the degree to which an innovation may be experimented with before adoption. The ability to test an innovation before adopting it is a critical factor in the success of an innovation's diffusion.

## User Evaluation of a Visual Approach to Cloud Security

**HYPOTHESES**

The newly developed approach for cloud security uses visualizations to detect malware present in VM or container files. It presents a number of advantages over prevailing methods; it incorporates visual aids for conveying information, it mitigates information overload, and it provides authoritative information to support decision making [11]. Visual evidence of malware within a virtual machine disk or container file is more intuitive than reports [18]. Further, decisions based on this information are easier to justify to cloud customers. If a string of malicious code can be visually presented to customers then they will be less apt to complain [14].

An example of a rootkit embedded in a python library within a container is depicted in Figure 2 (below). The left image projects a container image file with a rootkit. The image on the right is a depiction of the same container except it has no malware installed. A comparison of the two visualizations clarifies where the malware begins and ends.

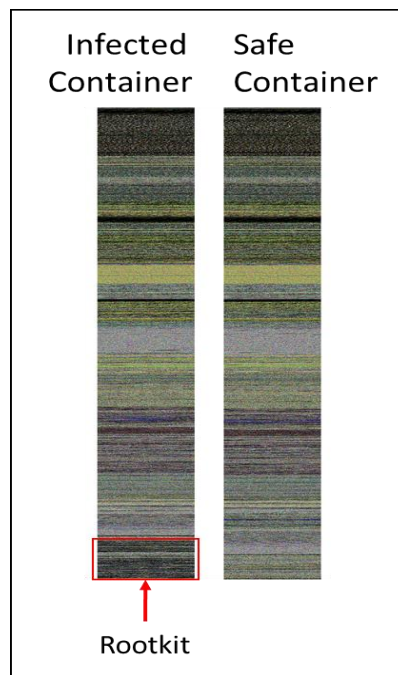

**Figure 2: Visual Recognition of Malware Within a Container**

The proposed new, visual method for inspecting the integrity of VMs and containers is expected to be well-received among potential users. It requires significantly less training than methods which rely on log reading and analysis. This approach only requires users make comparisons between visualizations of known-good VMs or containers and their counterparts used in production. Differences between the images are indicative of anomalies. When anomalous areas

## User Evaluation of a Visual Approach to Cloud Security

---

are located the potential users would consult a database of visual malware signatures in order to source the intrusion. In the future, this step will be computer-aided. This approach can be taught to undergraduates in approximately an hour because relatively little technical expertise is required.

In terms of hypotheses, several conjectures are offered. The proposed new method demonstrates relative advantage over existing methods [10]. It requires less log reading, makes decision-making easier, and takes less time. Hence:

*H1: The new approach will offer relative advantage.*

The new approach is also expected to offer greater levels of compatibility with organizational goals, values, needs and past experiences of potential users. This is because the proposed approach to integrity checking is aligned with organizational needs and it diminishes the difficulty that analysts face in trying to reach the correct classification decisions [17]. Therefore, the following hypothesis is offered:

*H2: The new approach will offer compatibility with adopters' needs.*

Although the new approach is different and it requires new analytical skills, it is expected to be less complex than the approaches which involve cross-comparison of logs, activity files, and malware detection reports [6]. Hence, the third hypothesis is:

*H3: The proposed new approach will be less complex than existing approaches.*

In terms of observability, it is expected that the proposed approach will offer significant benefits over other approaches. It will be easier to follow someone's efforts using the visual approach compared to approaches which involve file analysis and log reading [23]. Thus, the fourth hypothesis is:

*H4: The proposed new approach will be more observable than existing approaches.*

Finally, the new method is expected to be easier to trial and evaluate than other methods. This is because the new method requires less training and experience than other methods. It would be easier to evaluate the new method than other methods, because prevailing methods are difficult to test out [24]. Hence it is proposed:

*H5: The proposed new approach will be easier to trial than existing approaches.*

## METHODS

The purpose of the methods section is to evaluate user perceptions of the proposed new approach for cloud security testing. The hypotheses outlined in the previous section will be evaluated.

---

 User Evaluation of a Visual Approach to Cloud Security
 

---

The method of data collection is online survey. The survey is comprised of scales for operationalizing the constructs of the Perceived Attributes of Innovations. It is based on the measures developed by Moore and Benbasat (1991). The survey consisted of 22 items. Relative advantage and complexity both has 6 items. Compatibility has 3 items. Observability has 5 items. Trialability has 2 items. The items are rated using Likert-style scales with 1 – 5 point responses (1 = strongly disagree; 3= neither agree nor disagree; 5 = strongly agree).

The population of interest includes all individuals who work in the information technology field who either deploy VMs or containers, manage cloud architectures, or work in cloud security. A realistic sample of this population was achieved by recruiting 178 IT professionals from around the globe. The individuals all had prior experience using public clouds such as Azure, AWS, or Google. The subjects were recruited using an online platform called Amazon Mechanical Turk. Participants were offered a two dollar Amazon credit for participating in the survey. Prior to beginning the survey, the subjects were screened to ensure that they had some background in cloud computing and cyber security. Some basic questions regarding virtual machines, containers, and cloud security were presented. Those who did not correctly answer the questions were not included in the analysis. This resulted in a final sample of 172 individuals.

After the surveys were completed the data was analyzed using SPSS. Tests of sample size, response bias, normality, and linearity were conducted with favorable results. The data is found to be sufficient for multivariate analysis. After tabulating the demographic data (Table 1), a factor analysis of the Perceived Attributes of Innovations is performed (Table 2). The results indicate that the items load onto their respective factors without significant cross loading.

<b>Variable</b>	<b>Total</b>	<b>Respondents</b>
Gender	130	Male
	40	Female
	2	Other
	0	Prefer not to say
Age	18	18 – 22
	98	22 - 30
	41	31 - 40
	14	41 - 50
	1	Over 50
Education	0	Less than high school
	0	High School
	56	Some college
	59	Undergraduate
	37	Some Graduate
	20	Graduate Degree
Experience	22	Less than 1 year
	128	1 – 3 years
	19	4 – 5 years
	3	6- 10 years
	0	More than 10 years

**Table 1: Sample Demographics**

## User Evaluation of a Visual Approach to Cloud Security

Construct	Item	Latent Construct				
		ADV	COMPLEX	COMPAT	OBS	TRIAL
Relative Advantage	ADV1	.884	.337	.345	.263	.384
	ADV2	.849	.373	.542	.373	.300
	ADV3	.926	.341	.297	.288	.384
	ADV4	.878	.211	.273	.229	.372
	ADV5	.914	.075	.394	.237	.485
	ADV6	.909	.253	.293	.274	.384
Complexity	COMPLEX1	.472	.826	.395	.394	.408
	COMPLEX2	.204	.872	.345	.384	.387
	COMPLEX3	.349	.889	.402	.459	.392
	COMPLEX4	.405	.812	.398	.432	.293
	COMPLEX5	.248	.835	.395	.473	.350
	COMPLEX6	.450	.836	.464	.405	.348
Compatibility	COMPAT1	.490	.342	.921	.448	.299
	COMPAT2	.394	.293	.874	.505	.512
	COMPAT3	.376	.405	.935	.492	.551
Observability	OBS1	.402	.503	.495	.903	.495
	OBS2	.483	.398	.478	.823	.501
	OBS3	.439	.294	.283	.826	.304
	OBS4	.456	.451	.385	.876	.421
	OBS5	.507	.403	.372	.881	.487
Triability	TRIAL1	.398	.456	.497	.359	.815
	TRIAL2	.489	.501	.449	.479	.801

Table 2: Loading and Cross-Loading Matrix

## RESULTS

The results of the study are summarized in Table 3. As predicted, the artifact was favorably received by the subjects. The visual approach to integrity inspection was found to have relative advantage, compatibility, and observability. For these characteristics, the respondents averaged above 4.0 on a scale of 1 – 5 (average score of 4.4). The new approach was found to be less favorable in terms of trialability (average score of 3.1) and complexity (mean of 2.8). Given that a 3.0 / 5.0 indicates that a subject neither agreed nor disagreed with a statement, the subjects were neutral regarding the latter aspects. Hence, hypotheses three and five are rejected. The results are summarized in Table 3 (below).

## User Evaluation of a Visual Approach to Cloud Security

Item	Hypothesis	Mean Response	Result
H1	The new approach will offer relative advantage	4.8	Supported
H2	The new approach will offer compatibility with adopters' needs	4.6	Supported
H3	The proposed new approach will be less complex than existing approaches	2.8	Rejected
H4	The proposed new approach will be more observable than existing approaches	4.0	Supported
H5	The proposed new approach will be easier to trial than existing approaches	3.1	Rejected

**Table 3: Results of Analysis****CONCLUSIONS**

This research investigated user perceptions of a new visual approach to inspecting the integrity of cloud-based assets such as virtual machines and containers. The new method was evaluated by potential users. The results are generally positive. The new approach is seen as offering relative advantage, compatibility, and observability. Two aspects of the new approach were found to be less desirable. Respondents had neutral opinions about the complexity and trialability. Although the new method requires less training and time commitment than other methods, individuals who are already versed in traditional approaches to integrity checking may see the new approach as requiring more effort. More testing will be required to confirm this. Further, the new method perceived as being harder to trial. Perhaps this is a corollary of the perceived complexity. If a concept is difficult to understand then it would be hard to test. Future research will be focused on testing the impact of user perceptions on behavioral intentions and usage behavior.

**REFERENCES**

- [1] Bagozzi, R., Tybout, A., Craig, S., and Sternthal, B. 1979. "The construct validity of the tripartite classification of attitudes," *Journal of Marketing Research* (16:1), pp 88-95.
- [2] Bahram, S., Jiang, X., Wang, Z., Grace, M., Li, J., and D., X. Year. "DKSM: Subverting Virtual Machine Introspection for Fun and Profit," 29th IEEE Symposium on Reliable Distributed Systems, New Delhi, IN, 2010.
- [3] Basu, S., and Bultan, T. 2016. "On deciding synchronizability for asynchronously communicating systems," *Theoretical Computer Science* (656, Part A) 12/20/, pp 60-75.
- [4] Benninger, C., Neville, S., Yazir, Y., Matthews, C., and Coady, Y. Year. "Maitland: Lighter-Weight VM Introspection to Support Cyber-security in the Cloud," 2012 IEEE 5th International Conference on Cloud Computing, Honolulu, HI, 2012.



## User Evaluation of a Visual Approach to Cloud Security

- 
- [5] Bentler, P., and Bonnett, D. 1980. "Significance tests and goodness of fit in the analysis of covariance structures," *Psychological Bulletin* (88:3), pp 588-606.
- [6] Chen, H., and Li, W. 2014. "Understanding organization employee's information security omission behavior: An integrated model of social norm and deterrence," in 18th Pacific Asia Conference on Information Systems (PACIS 2014) Chengdu, CN.
- [7] Jansen, W. 2011. "Cloud Hooks: Security and Privacy Issues in Cloud Computing," in 44th Hawaii International Conference on System Sciences: Kauai, HI.
- [8] Kandukuri, B., Paturi, R., and Rakshit, A. 2009. "Cloud Security Issues," in 2009 IEEE International Conference on Services Computing: Bangalore, IN.
- [9] Lee, D., Song, I., Kim, K., and Joeng, J. 2011. "A Study on Malicious Codes Pattern Analysis Using Visualization," in 2011 International Conference on Information Science and Applications: Jeju Island, South Korea.
- [10] Limayem, M., Hirt, S., and Cheung, C. 2007. "How habit limits the predictive power of intention: The case of information systems continuance," *MIS Quarterly* (31:4), pp 705-737.
- [11] Luo, X., and Warkentin, M. 2008. "Malicious code: Developments and defenses," in *Encyclopedia of Multimedia Technology and Networking*, M. Pagani (ed.), Idea Group Publishing: Hershey, PA.
- [12] Mickelberg, K., Schive, L., and Pollard, N. 2014. "US Cybercrime: Rising Risks, Reduced Readiness – Key Findings from the 2014 US State Of Cybercrime Survey," Price Waterhouse Coopers, pwc.com.
- [13] Moore, G., and Benbasat, I. 1991. "Development of an instrument to measure the perceptions of adopting an information technology innovation," *Information Systems Research* (2:3), pp 192-222.
- [14] Morrin, M., and Chebat, J. 2005. "Person-place congruency: The interactive effects of shopper style and atmospherics on consumer expenditures," *Journal of Service Research* (8:2), pp 181-191.
- [15] Munzner, T. 2014. *Visualization Analysis and Design*, (CRC Press: New York, NY).
- [16] Nance, K., Hay, B., and Bishop, M. 2008. "Virtual Machine Introspection Observation or Interference?," *IEEE Security & Privacy* (6:5), pp 32-37.
- [17] Polites, G., and Karahanna, E. 2012. "Shackled to the status quo: The inhibiting effects of incumbent system habit, switching costs, and inertia on new system acceptance," *MIS Quarterly* (36:1), pp 21-42.
-

User Evaluation of a Visual Approach to Cloud Security

---

- [18] Posey, C., Roberts, T., Lowry, P., Bennett, R., and Courtney, J. 2013. "Insiders' protection of organizational information assets: Development of a systematics-based taxonomy and theory of diversity for protection-motivated behaviors," *MIS Quarterly* (37:4), pp 1189-1210.
- [19] Puhakainen, P. 2006. "A Design Theory for Information Security Awareness," Faculty of Science, Department of Information Processing Science, University of Oulu.
- [20] Rogers, E. 1983. *Diffusion of Innovations*, (The Free Press: New York, NY).
- [21] Rogers, E. 1995. *Diffusion of Innovations*, (The Free Press: New York, NY).
- [22] Rogers, E., and Shoemaker, F. 1971. *Communication of Innovations: A Cross-Cultural Approach*, (The Free Press: New York, NY).
- [23] Shropshire, J., Warkentin, M., and Sharma, S. 2015. "Personality, attitudes, and intentions: Predicting initial adoption of information security behavior," *Computers & Security* (29), pp 177-191.
- [24] Vance, A., Siponen, M., and Pahlila, S. 2012. "Motivating IS security compliance: insights from habit and protection motivation theory," *Information & Management* (49:3), pp 190-198.
- [25] Watts, T., Benton, R., Glisson, W., and Shropshire, J. 2019. "Insight from a Docker Container Introspection," in *Proceedings of the 52nd Hawaii International Conference on System Sciences*: Maui, HI.
- [26] Wei, J., Zhang, X., Ammons, G., Bala, V., and Ning, P. Year. "Managing Security of Virtual Machine Images in a Cloud Environment," *Proceedings of the 2009 ACM workshop on Cloud computing security*, Chicago, Ill, 2009, pp. 91-96.
- [27] Win, T., Tianfield, H., Mair, Q., Said, T., and Rana, O. Year. "Virtual Machine Introspection," *Proceedings of the 7th International Conference on Security of Information and Networks*, Glasgow, UK, 2014.

**Innovative Education,  
Assessment, Engaged  
Learning, Curriculum,  
Teaching and Pedagogy -  
Abstracts**

# A Comparative Study of the Perspectives of Students and Faculty on Perceived Responsibility for Learning

---

Regular Session

---

***Dr . Farshid Azadian*** <sup>1</sup>

*1. Embry-Riddle Aeronautical University*

Numerous studies have shown the importance of self-discipline in the success of students in learning. In this research, we investigated students' perceived responsibility for learning (PRL) at the post-secondary level. We surveyed junior and senior level undergraduate students enrolled in a business and a non-business four-year degree program. In addition, we surveyed the faculty for their perceptions of the shared responsibility for learning between students and instructors.

---

# A Study on Social Presence and Gender in Online Learning

---

Regular Session

---

*Dr . ChongWoo Park*<sup>1</sup>, *Dr . Dong-gook Kim*<sup>2</sup>

*1. Augusta University, 2. Dalton State College*

While online classes become more popular in higher education, there have been challenges to students' learning experience in online learning. One critical challenge would be providing interactions between students and instructors as good or effective as in the face-to-face learning. Prior research on student success in online college courses has pointed out that the interactions between students, their peers, and their professors in online courses are different from those in face-to-face courses. Students may perceive the lack of interactions in online courses because instructors and peer students are not physically present together. Such lack of interactions due to no physical presence may negatively affect student performance in online learning. In this study, we introduce social presence in online learning as an alternative to physical presence in the face-to-face learning, and investigate the role of social presence as student learning experience in online learning. While gender difference has been studied in traditional face-to-face learning, there have been few empirical studies on gender difference in online learning, whose results are often contradictory. In addition, there has been little research that investigates the effect of gender difference on social presence in online learning. In this study, we also attempt to examine the role of gender difference in building social presence in online learning. Thus, we pose the following research questions.

How can we promote social presence in online learning?

What is the role of gender difference in establishing social presence in online learning?

In answering the questions, we draw on the social presence and online learning literature, and propose a research model to explain how interactive communication tools can drive social presence and student satisfaction in online learning.

To test the research model, we collected survey data from undergraduate students who were taking online business statistics courses where an interactive communication tool was required to use for class communication and collaboration. Preliminary data analysis shows that social presence driven by tool interactivity has a significant impact on student satisfaction in online learning, in which social presence fully mediates between interactivity and satisfaction. This finding implies that not only interactive tools but any other tools or activities that can increase social presence may contribute to student satisfaction in online learning. Thus, educators may be able to take advantage of this finding by employing a tool or an activity to help students build higher social presence in online learning. Our results also show that gender difference moderates the relationship between interactivity and social presence in online learning.

# AN ANALYSIS OF STUDENT SATISFACTION WITH CLASSROOM DESIGN

---

Regular Session

---

***Dr . Kenneth MacLeod <sup>1</sup>, Dr . William Swart <sup>1</sup>***

*1. East Carolina University*

Problem-based learning is the latest name for a teaching philosophy that is as old as Ancient Greece. Whether you call it Socratic Inquiry, case-based teaching, problem-based learning or even “flipped” teaching, the essential concept is to challenge the student to think, applying knowledge gained to solve a problem. As this teaching approach has begun to challenge traditional, lecture-based teaching, the design of classrooms has been called into question. A flat or tiered room, with desks or tables in neat rows, is not seen as an ideal setting for collaborative work. In our own school, several traditional classrooms were converted to Problem-Based classrooms at considerable expense. This paper explores whether moving students into these high-tech classrooms improves the learning experience, measured as student satisfaction with their class.

# An Exploratory Study of Student Learning Styles in Undergraduate Decision Sciences Classes

---

Regular Session

---

***Dr . Morgan Shona <sup>1</sup>, Dr . Sherrie Drye <sup>1</sup>, Dr . Patrick Rogers <sup>1</sup>***

*1. North Carolina Agricultural and Technical State University*

One of the primary missions of higher education is to ensure that students gain skills and knowledge that will be a foundation for future academic and career success. However, many students enter college and are unsure about what they can do to help themselves succeed. We argue that an awareness of student learning styles can help both students and faculty have better learning transparency so that the focus is on mastery of course content. Our work augments a growing base of literature focused on the use of student learning style data to promote greater student success in collegiate coursework. Preliminary results are presented to describe the predominate learning style of students in three different decision science oriented courses. Suggestions for additional analysis are presented. Our aim is to understand how student learning styles and course pedagogical practice correlate to student performance. We assert that this knowledge is critical to inform course design and re-design within the discipline.

## Assessment

---

Regular Session

---

***Dr . Linda Champion*<sup>1</sup>, *Dr . Diane Lending*<sup>2</sup>, *Dr . Hope Baker*<sup>3</sup>**

*1. East Carolina University , 2. James Madison University , 3. Kennesaw State University*

Hope Baker will discuss the evolution of assessment in the Coles College of Business, from the creation of a course-embedded assurance of learning model for AACSB purposes in the mid-2000's to a comprehensive assessment plan for courses, programs and student success metrics designed to satisfy requirements of multiple accrediting bodies. Assessment methods, faculty involvement, staff and IT support needs, and the shift in emphasis to a Student Success focus are among the topics to be discussed.

Diane Lending will discuss an integrated system for program learning improvement. A pig never fattened up because it was weighed. Similarly, students do not learn more because they are assessed. In this presentation, I present a model and example of demonstrating evidence for learning improvement at the program level based upon the premise of weighing the pig, feeding the pig, and reweighing the pig. In other words, I will describe the process of assessing a learning objective, designing and implementing an intervention that crosses the curriculum, and reassessing progress relative to the objective.



# Blockchain Education for Diverse Populations

---

Regular Session

---

***Dr . Jack Crumbly*** <sup>1</sup>

*1. Tuskegee University*

As Software organizations look at methods to introduce Blockchain concepts to populations, a combined approach of use case and classroom methods has been implemented at an HBCU since 2017. This research looks at which methods were implemented to introduce Blockchain technology using partnerships from several organizations to implement the technology to diverse undergraduate and graduate students. The research will also discuss challenges and shortcomings of the effort and next steps in the research.

# Business School Governance in the Contemporary Reality

---

Regular Session

---

***Dr . Frank Butler <sup>1</sup>, Dr . Lisa Burke-Smalley <sup>1</sup>***

*1. University of Tennessee at Chattanooga*

How colleges of business operationalize their governance structures has received scant attention in the management education literature. Yet, today's business faculty are tasked with making meaningful contributions to their community, corporate stakeholders, as well as in research and student learning, making faculty performance outputs key to metrics of college success. To address the literature gap, we briefly review the history of university governance and then 1) create four categories of decisions and suggest varying degrees of faculty input (voice vs. vote) for each, and 2) propose alternative governance options for colleges of business to be considered in the contemporary reality, each with pros and cons. We suggest the most appropriate governance approach depends upon the college's external environment, culture, and other contextual dimensions. Finally, we provide guidance for future research.

# Corporate Partnerships: A Key to Success of Business Schools

---

Regular Session

---

*Dr . Margaret Thompson <sup>1</sup>, Dr . Jacob Chacko <sup>1</sup>, Ms . Krystle Carter <sup>1</sup>*

*1. Clayton State University*

For Business Schools to succeed in the future, they need to develop strong partnerships with businesses, ensure the professionalism of their graduates, incorporate experiential learning into the curriculum, embrace life-long learning of students and faculty, be agile in programming and curriculum, leverage technology, look for interdisciplinary collaborations, and be truly global in thought, program, and plan. The Corporate Partnership program and the career spine address most of these critical success factors.

The College of Business at Clayton State University has integrated a Career Spine within the business curricula that provides 21st Century Work Skills along with both broad and major-specific business knowledge. The Career Spine connects faculty members and Corporate Partners with students through core business courses.

The Corporate Partner Program is designed to develop a talent pipeline for our Corporate Partners for internship and job placement. The Career Spine within the Business Core Curriculum, along with active engagement of Corporate Partners, ensure that students are career ready at graduation. Members of the Corporate Partner Program serve as Advisory Board Members; Executives-in-Residence who mentor students; and Employers-In-Residence who ensure their career readiness. While the Career Spine offers immense benefits to our students, it also offers our Corporate Partners priority access to a steady supply of well-prepared business graduates.

This paper summarizes key research about corporate partnerships in Business Schools, reports results of a successful Corporate Partnership Program, and provides guidance for successful implementation of a Corporate Partnership Program.

Key words: corporate partner, Business Schools, career readiness, Advisory Board

# Data Envelopment Analysis: Reflections on Usage in Management

---

Regular Session

---

***Dr . William Kline <sup>1</sup>, Dr . Richard Brown <sup>1</sup>***

*1. PSU - Harrisburg*

*Abstracts should be between 250 and 450 words and SHOULD include names and affiliations.*

*William A. Kline, PhD  
Assistant Professor of Management  
Pennsylvania State University—Harrisburg  
777 W. Harrisburg Pike  
Middletown, PA 17057  
(717) 948-6666 Phone  
wak14@psu.edu*

*Richard S. Brown, PhD  
Assistant Professor of Management  
Pennsylvania State University—Harrisburg  
777 W. Harrisburg Pike  
Middletown, PA 17057  
(717) 948-6676 Phone  
rsb24@psu.edu*

Data Envelopment Analysis (DEA) is a statistical method that draws on production function tenets to calculate efficiency measures based on input/output ratios and “has emerged as a preeminent methodology for assessing the relative efficiency of decision-making units.” (Fizel and D’Itri, 1999, p. 570) Keyword searches for “DEA” yield thousands of articles covering wide-ranging topics from marketing benchmarking (Donthu, Hershberger, and Osmonbekov, 2005), to sports management (Howard and Miller, 1993), to education (Mayston, 2003). Despite the sound foundation for Data Envelopment Analysis logic and applications, as well as a forty-year track record and wide acceptance in a number of fields, the usage of DEA in management (particularly, strategy, human resources, and organizational behavior) business curriculum and research remain scarce. Why does the usage of DEA in mainstream management literature and management business curriculum remain so limited?

In this paper, we provide evidence of what appear to be isolated pockets of DEA usage in the management literature. Given this, we endeavor to spark debate across a wide audience consisting of existing management scholars, Ph.D. students, practitioners, and curriculum designers. More specifically, we discuss: (a) recent DEA usage in management and business research, (b) reasons for using DEA more frequently in management research and practice, and, (c) DEA coverage in the curriculums of top research schools. Our study of this topic contributes to discussions about DEA methodology in management research and management curriculum design. In addition, we also link our findings to the discussion pertaining to scientific advancement, specifically the tension between integration and specialization, and following Mudambi, Hannigan, and Kline (2012), we use Ph.D. programs in management as the study context.

# **Design Innovation for Masters in IS/IT: An Accelerated Program Model to Meet Workforce Gap Needs**

---

Regular Session

---

***Dr . Albert J. Wynne <sup>1</sup>, Dr . Elizabeth Baker <sup>1</sup>***

*1. Virginia Commonwealth University*

This paper presents an innovative design for creating an accelerated Masters in Information System degree program for the purpose of addressing the IT/IS workforce gap for mid-level to senior level professionals who can lead the technologists who are graduating from associate degree, bachelor degree, and certificate programs. The curriculum is designed to be more affordable and more aggressive in producing qualified IS/IT professional leaders.

---

# DETERMINANTS OF PERFORMANCE OUTCOMES IN BUSINESS SIMULATIONS USING KOLB'S LSI

---

Regular Session

---

***Dr. Robert Hasbrouck<sup>1</sup>, Prof. Scott Walker<sup>1</sup>***

*1. Christopher Newport University*

The use of experiential learning-based assignments and projects in higher education has been well cited as a positive way to improve learning (Kolb and Kolb, 2005; Trautrim et. al., 2016, 2000; Xu and Yang, 2010, and many others). The Experiential Learning Theory (ELT) posits that new experiences create new knowledge and understanding through the interaction of acquisition and transformation (Kayes, 2002). Much of the recent literature uses Kolb's Learning Style Inventory (LSI) survey to support the tenets of the experiential learning process (Hawk and Shah, 2007; Kamis and Kahn, 2009; Peterson and Kolb, 2018). Although there are a limited number of studies that compare learning styles to performance (Armstrong and Mahund, 2008), the use of Kolb's LSI as a predictor or identifier of student performance has yet to be examined. In this paper we examine student performance in a business simulation and compare the results to the LSI profile to determine the relationship between learning style and simulation performance. Specifically, we are interested in the following research questions;

- 1) Simulation Performance: Are there performance differences between the LSI constructs (CE – concrete experience, RO – reflective observation, AC – abstract conceptualization, AE – active experimentation, CE-AC and AE-RO)?
- 2) Student Major: Does one's business major favor one of the Kolb LSI constructs?
- 3) Gender and simulation outcome: Does gender play a role in selection of th LSI constructs? Is gender a factor in simulation performance?

The preliminary results indicate a pattern of performance within the Kolb profiles and suggests that student performance can be influenced by additional factors including major and gender, which has been reported in a prior study (Garber, et.al., 2017). The authors invite those who use, or are considering the use of, business simulations in their pedagogy to collaborate in this ongoing study to expand scope of the initial research findings.

## Enhancing CIS Program Curriculum with Certifications

---

Regular Session

---

***Mr . James Jewett <sup>1</sup>, Dr . Tom Dillon <sup>1</sup>, Mr . Austin Crouch <sup>1</sup>***

*1. James Madison University*

The purpose of this study was to assess the current views of employers in the IT field with regard to IT certifications for entry-level employees. A literature review was completed as well as a survey project which investigated the opinions of major employers of James Madison University Computer Information System graduates. Employers value perspective entry-level employees with these certifications as well as encourage and support current employees to obtain them. Preparing CIS degree program students for the more valuable technology certifications is a desirable goal which would lead program faculty to introduce/improve courses that support students' efforts to obtain certifications.

# Enhancing Student Learning Through an Iterative Self-Based and Peer-Performance Comparison System

---

Regular Session

---

***Dr . Kameleddine Benameur*** <sup>1</sup>

*1. Gulf University for Science and Technology*

This paper aims to pilot an iterative, student-centered, learning process that focuses on reflection and evaluation of practice, through the use of the Pearson's MyLab platform. We expect that this e-learning platform will empower students to engage more effectively with feedback to improve their performance as it integrates key pedagogical pillars of self-assessment and self-reflection. Peer-Performance Comparison is made through another platform, the LMS used being Moodle, making the overall results available so students could share them. The new system also includes limitation on the number of attempts thus motivating them to focus in order to achieve higher scores.

The accounting education is facing many challenges at different levels. The future that seems to be dominated by artificial intelligence including in the accounting sphere does not leave the future accountants any choice but to raise to the challenge. It is however as challenging as ever for educators to enhance student learning when technology invades any available student attention and captures every intelligent moment. The answer would be to use the technology rather than resist this transformational moment. Even if artificial intelligence and augmented data analytics could change the future of the accounting profession, in modern accounting education it is expected that students' interactivity in the classroom and within Learning Management Systems would improve learning outcomes.

Nowadays, the accounting profession and by ricochet the accounting education is living a great transformation. It is driven by the technology and changing expectations of the market. It requires educators to be on the forefront of the arising issues and challenges. Educators have the responsibility to lead the way. The amount of change, therefore the amount of opportunities, is greater than ever. Creating an environment where students embrace the change, and using the right methods to improve their involvement and achievement, is a very stimulating and fulfilling prospect. One of those strategies, is to enhance the students' learning through the use of hands on e-learning system. We add the disclosure of the overall results in the LMS as a motivating factor for better achievements. This simple step is expected to have significant impact on academic success in accounting courses.



# Ethical Issues in Online Accounting Education

---

Regular Session

---

***Dr . Patsy Lewellyn***<sup>1</sup>

*1. University of South Carolina Aiken*

This paper will review current literature in online education, specifically online accounting education, focusing on ethical issues, addressed and presently unaddressed but potentially significant. Ethical issues identified in extant literature will be categorized using a model of online education (Simonson et al., 2002). Building on previous studies the author will provide experience (personal and that of colleagues) of issues that have been experienced in the online environment, bringing to light subtle, perhaps overlooked, ethical questions yet to be explored.

# Feeding the Pig: An Integrated System for Program Learning Improvement

---

Regular Session

---

***Dr. Diane Lending*** <sup>1</sup>

*1. James Madison University*

A pig never fattened up because it was weighed.” Similarly, students do not learn more because they are assessed. In this presentation, we present a model and example of demonstrating evidence for learning improvement at the program level based upon the premise of weighing the pig, feeding the pig, and reweighing the pig. In other words, we will describe the process of assessing a learning objective, designing and implementing an intervention that crosses the curriculum, and reassessing progress relative to the objective. The objective chosen was a soft-skill: “Students will be able to conduct an effective requirements elicitation interview.” The program was the Computer Information Systems program at James Madison University. The results have been amazing; in just one year, the students’ skills have increased by 1.13 on a 5-point scale, with an effect size of over 3 standard deviations. In our presentation, we will describe the motivation behind and the design for the project. We will explain the step-by-step procedure used. We will discuss the motivating techniques we used to get faculty involved in this project. We will also show videos of student interviews before and after the intervention.

# First Gen[ethics]: Fostering Mutual Understanding for Greater Success

---

Regular Session

---

***Mr. James Winfield*** <sup>1</sup>

*1. Benedict College*

According to a 2019 report from The Pell Institute for the Study of Opportunity in Higher Education, the percentage of “students with the potential to be first-generation college students” sits at 60% across all races (The Pell Institute for the Study of Opportunity in Higher Education, 2019, p. 22). With this substantive number of first-generation college students (FGCS) coming to college, it is the responsibility of institutions to support them in achieving academic success. This session will share trends and practices to consider when designing programs centered around the success of FGCS along with the various nuances that may affect these students as they navigate the collegiate environment.

## Grants Requirement and Faculty Performance Assessment at Selected Business Colleges

---

Regular Session

---

***Dr . Kai Koong <sup>1</sup>, Dr . Lai Liu <sup>2</sup>, Dr . Haoyu Wen <sup>3</sup>, Mrs . Yuntao Zhang <sup>3</sup>***

*1. Tuskegee University , 2. The University of Texas Rio Grande Valley , 3. Xidian University*

As corporate and governmental grant money play an increasing important role in research and service, more and more universities are expecting faculty to participate in grantsmanship. This is understandable because budgets for higher educations are getting smaller. Institutions are being asked to either do more with less or to begin doing less with less. Obviously, grants are a source that can be tapped. Using a convenient sample, this pilot study examines grantsmanship requirements and faculty performance assessment at selected business schools. In particular, this study examines the practice of grantsmanship at AACSB accredited institutions as to how these sources are valued in the performance matrices. Faculty, administrators and unions will find this study interesting.

# Higher Education Can Improve Efficiency, Reduce Waste, and Save Millions: Some Remarkably Simple Changes

---

Regular Session

---

*Dr . Taiwo Amoo <sup>1</sup>, Dr . Hershey H Friedman <sup>1</sup>*

*1. BROOKLYN COLLEGE, CITY UNIVERSITY OF NEW YORK*

Most institutions of higher learning have a mindset that might have made sense in the industrial age but is dangerous in the knowledge economy. One researcher claims that half of the 4,000 colleges and universities in the United States will be bankrupt within the next few decades. Change is coming whether colleges and universities like it or not. Think of what is happening to the newspapers and retailers. The institutions of higher education that survive will be the ones that learn how to eliminate waste and be efficient. This paper highlights several simple changes that have the potential of saving colleges millions of dollars. These freed up resources may then be used to improve quality.

Keywords: Reducing waste in education, networking universities, merging colleges, hierarchical organizational structure, administrative bloat, silo-busting, RCM, prioritizing criteria, outcomes assessment, and academic departments.

## INFO16X Digital Literacy Program

---

Regular Session

---

***Mrs . Wilma Andrews <sup>1</sup>, Dr . Bob Andrews <sup>1</sup>, Mr . Ashish Sunita <sup>1</sup>, Ms . Sindhu Venkatesh <sup>1</sup>***

*1. Virginia Commonwealth University*

Virginia Commonwealth University (VCU) School of Business has a large program of online/self-passed/pass-fail/1 credit courses in Digital Literacy. School administrators observed that these classes traditional have a pass rate in the 70% range. They sought to determine the reason for the low pass rate. They concluded there were two major issue: procrastination on the student's part and students not completing the training and/or wait until the very end of the semester to schedule their exams. New policies including required Sequential Modules and early first exam attempt deadlines were initiated for Fall 2019. This paper will compare previous semester results vs. current ones to see if new policies were effective in improving the pass level.

# INNOVATIVE EDUCATION AT STUDENTS' FINGERTIPS: USING LMS PERFORMANCE FEEDBACK MECHANISMS TO RETURN CONTROL OF LEARNING PROGRESS TO STUDENTS

---

Regular Session

---

*Dr . Ruth C. King*<sup>1</sup>

*1. Fayetteville State University*

## **ABSTRACT**

Many introductory or online courses face high “DFW” issues. High failure rates can be attributed to many factors, but the consequences are significant not only to students and instructors but the society and future workforce. This study documents a series of experiments by applying different performance feedback mechanisms to provide students with real time performance signals and to keep them informed about their learning outcomes. The background of this study is a self-guided software learning course (Microsoft Office Suite) with five individual modules: Basic Computing, Word, Excel, Access and Power Point. Instructors serve as coaches to guide the progress of modules, remind students of the deadline and solve technical and learning problems. One of the major concerns in this course was the low performance of student’s learning outcome. Since this course involves 22 assignments (15 training, 3 projects, and 4 midterms) with various weights assigned to each assignment, students frequently asked instructors to calculate/update their current performance. Feedback research has shown that providing prompt and meaningful feedback to learners about their learning status is beneficial to motivate them to continue their learning journey and achieve their final goals. Apparently, student’s knowledge of their performance at any moment can be significant information for them to identify their learning gap, current performance and strategies to steer their future effort in time to reach their expected outcome.

Three different controls were implemented to three different groups of students (28 students in each group) under the same instructor. The first experiment was to teach students to apply the grading formula posted on the syllabus so students can obtain their status any time on their own. The second experiment was to apply the assignment grouping mechanism and assignment weighting scale embedded in the Learning Management Systems (LMS) so that the overall performance can be published on the LMS synchronously with the assignment Software. The third experiment was to creatively modify the performance feedback mechanism provided by LMS since the mathematical logic behind the grading program is not reflecting the actual scores in relationship with the formula

The results show that DFW rates under the first and second experiment experienced minor decrease of DFW rates from the baseline but students under the third experiment experienced more significant decrease. The findings suggest that true performance feedback that allows students to access at any time returns control to students. This technology-enabled feedback mechanism helps direct students’ continual effort and enable them to devise productive strategies to reach their learning goals. Statistics will be presented at SEDSI.

# Learning Engaged Scholarship through a MIS STEM Camp

---

Regular Session

---

***Dr . April Reed <sup>1</sup>, Mrs . Lyubov Sluder <sup>1</sup>***

*1. East Carolina University*

Many students in public education are limited in their access to Science, Technology, Engineering and Math (STEM) education. STEM camps are a common method used to introduce students to these important disciplines. This research study began as an Engaged Scholarship project; a Management Information Systems (MIS) STEM camp to introduce participants to technology and targeting middle and high school girls. Surveys were used to measure the impact of the camp. Statistical analysis of results did not show a significant increase in attitudes towards technology, however, a positive change did occur in their confidence in the ability to perform technical work.



# Leveraging a Service-learning Approach to Teach a Graduate Course in Data Governance

---

Regular Session

---

*Dr . Uma Gupta <sup>1</sup>*

*1. University of South Carolina at Upstate*

Organizations recognize that taming the data lion is not an easy task. The volume, veracity, and variety of data that organizations must absorb and manage has exceeded the human capacity to manage and process data. This drives the need for strong data governance.

Data governance is defined as a set of policies, procedures, and processes to ensure that organizational data is treated as an asset. Data governance is the collective responsibility of all employees as it impacts the relationship between accessibility, usability, reliability, and timeliness of data and quality of decisions made by individuals and teams in an organization.

This paper relates to a first-time graduate course in data governance that was taught at medium-sized university in the Northeast. Rather than take a lecture-based approach, service-learning was used as a vehicle to teach students about the complexities of data governance and the “messiness” and challenges of crafting and implementing the core concepts of data governance.

Experts and practitioners of data governance know that while it looks easy on paper, it is extremely difficult to implement data governance in the real-world. This is because data governance is not a one-time project or a short-term initiative. It is a commitment that organizational leaders must make to ensure that data, which is dynamic and error-prone, will be treated and leveraged as an invaluable asset.

Service-learning is an excellent vehicle to teach data governance. Abstract concepts, such as usability or access, and over-simplified language such as policies and processes come to life through service-learning. Students face the arduous task of working on projects, some of which may have no clear starting place. There is no one final deliverable in data governance. Each deliverable becomes the input to the next deliverable and the next and so on.

This approach is not something that students are comfortable with. It teaches them to look long-term even as they address the short-term issues. They must become strategic thinkers and implementors of everyday tactics while continuously striving to help the organization become more sophisticated in data-driven decision-making. The class was divided into three teams of four students each. Each team worked with a different organization on a data governance project. In other words, the course had three project sponsors with different data governance projects. Each organization was at a different maturity level when it came to data governance. In addition, the culture of the organization and the sponsor’s engagement with the student also influenced student learning.

This paper captures the lessons learned from using a problem-based learning approach, student feedback, and opportunities to strengthen service-learning as a vehicle for active learning in the classroom.

# LINKING BLOCKCHAIN, SUPPLY CHAIN, AND STUDENT LEARNING: A CLASSROOM EXERCISE

---

Regular Session

---

***Dr . William Ritchie <sup>1</sup>, Mr . Jacob Decker <sup>1</sup>, Dr . Mert Tokman <sup>1</sup>***

***1. James Madison University***

With supply chain security awareness at an all-time high, new technologies have enabled managers to create innovative solutions to secure their supply chains. One such emerging technology is Blockchain. Yet, despite successes with the application of this innovation, it is so new that there is no mention of it in most supply chain and operations textbooks. Further, existing only in code and on digital platforms, blockchain remains an area where confusion runs high and understanding remains low. When describing blockchain as a distributed, decentralized, immutable public ledger, unfamiliar audiences can become lost in such a definition. Through two classroom exercises, the goal of this Teaching Brief is to equip students and professors with first-hand knowledge of how blockchain functions.

# Making Finance Real: Strategies and Models for Zoomers

---

Regular Session

---

***Dr . George Lowry*** <sup>1</sup>

*1. Randolph-Macon College*

Recent research identifies the group following the Millennials as “Zoomers” or Generation Z. Differing from Millennials who seek, among other things, to “make a difference”, Zoomers are more pragmatic and are motivated by career advancement and money. As a result, the current set of traditional college-aged students seek ways to meet those goals. Of interest to many are the options and financial choices facing them after graduation. This presentation demonstrates how the core elements of introductory finance courses can be extended to provide greater meaning and context. Examples include how credit scores (e.g. bond ratings), credit card debt (short-term financing and cash management), school loans (long-term debt and capital budgeting/rationing), retirement planning (Investments and security analysis), and evaluating employment compensation (risk/return, project evaluation) match up with the elemental topics normally covered. Employing these examples through small-scale projects and utilizing Excel as the calculation engine has seen a greater level of engagement by students and at the same time facilitated specific learning outcomes.

# Management Skills Desired by College Business Students and Business Employers

---

Regular Session

---

***Dr . Marjorie McInerney*** <sup>1</sup>

*1. Marshall University, Lewis College of Business*

Workplace jobs are changing with lifetime employment a thing of the past. Students and employees will face a lifetime of multiple occupations/jobs. The primary focus of employment and job change could very well be the skills that people acquire through education and employment. Job skills that are necessary for managers in business has become topic of concern in colleges of business. Beyond initial job skills, colleges should be concerned with developing career planning as an important skill for students and employees to learn (occupational choice/organizational choice; career self-development, choice of job assignment prior to entering the work force and before changing jobs. Many employers are now hiring based on job skills as opposed to educational degree or even work experience (Parento, Kelkar 2000).

The focus of this research was to examine the type of skills students feel they have learned in their undergraduate business programs and what skills they feel deficient in learning. A career skill assessment tool was utilized in three key areas: 1) management skills students feel strong in and skills in which they want further development; 2) how students rate themselves in work characteristics; and 3) the attributes of the ideal job for students.

Data from the career skill assessment tool was analyzed through SPSS looking at frequencies of responses and differences in gender responses. Descriptive analysis will also be used for specific open-ended questions concerning demographic information, work experience and professional achievements. Examples of professional behaviors and autonomy in the job were also gathered. This information along with student goals will also be presented in a comparative and descriptive format.

# Pedagogical Decisions and How to Improve Outcomes for First-Generation and Low-Income Students

---

Workshop

---

***Dr . Lee Ward*** <sup>1</sup>

*1. James Madison University*

They are in our classrooms, regardless of the type of institution we occupy, and we may not know it: first-generation and low-income students. They are too often poorly prepared, have lower expectations and aspirations than other students, tend to engage less in high impact educational practices, fail to take advantage of academic support services, achieve lower grades, work more hours, and graduate at a significantly lower rate than other students. They may be the most passionate, hard-working, and motivated students you have. And they need our intentional support.

In this workshop, I will share my years of research on and experience with these students to lead an interactive exploration of how faculty can transform their teaching and advising practices to ensure that first-generation and low-income students successfully navigate their transitions to and from our institutions and thrive in our classrooms. You'll gain not only a fuller appreciation of the unique struggles these students face, but will leave with practical strategies and valuable tools for helping them succeed in your course and beyond.

While the higher education literature is chock full of helpful descriptions of teaching and student development strategies - including my own book, *First Generation College Students: Understanding and Improving the Experience from recruitment to Commencement* (Jossey-Bass, 2012), we will reach outside of higher education for a model that perfectly captures what these student experience and need. The wellbeing model employed by the Full Frame Initiative (FFI), an NGO that helps communities address institutionalized poverty, violence, trauma and oppression, is a powerful framework for faculty who wish to improve the experiences and outcomes of low-income, first-generation, and other marginalized students. In this workshop, we will explore this model as a student success tool and create a language that can be used to improve the learning environments for all students. Participants will learn the five domains of the model - Social Connectedness, Stability, Safety, Mastery, and Meaningful Access to Relevant Resources - and use problem-solving exercises to discover how these domains affect student engagement and achievement in their classroom and beyond.

Regardless of what you teach or where you teach it, various segments of the student population need different things from us to achieve their potential. Join us to learn hands-on about what first-generation and low-income students need and how you can embrace their differences and ensure their success.

# Red Fox Mountain Ski Resort Management Case

---

Regular Session

---

***Dr . Thomas Garsombke <sup>1</sup>, Dr . Keith Miller <sup>1</sup>, Prof . Michael Smith <sup>1</sup>***

*1. Clayton State University*

The Red Fox Mountain Ski Resort Case deals with a small business, located in Eastern North Carolina, that is buffeted by internal and external factors. The case is based on a real business, but the name and location were changed at the owner's request. A brief history of its origination and development is presented. There are strategic management, financial, operational and external issues presented. Additionally, environmental issues appear to influence the profitability, growth, and survival of the resort. These internal and external issues require students to make major decisions using operational and financial information. Whether the students choose a growth strategy or a containment view, the students must justify their decision with appropriate data from the case and external sources. While the business is profitable and growing, external political, economic, and social factors are now major issues facing top management.

This case requires students to make strategic decisions and provide data and financial figures to justify their decision. Additionally, students must do external research on current and future environmental conditions which impact the business's operations and formulated strategies to deal with this threats and opportunities. This case can produce very good discussions and requires students to do pre-class work on current issues facing ski resorts planning and administration.

As the case is relatively short and requires a basic financial analysis, it is a good opener at the start of the semester, especially after lectures on external factors and their impact on business operations. The case was developed for use in undergraduate Strategic Management/Policy, Small Business Management, and Principles of Management courses.

# Roleplaying as a Pedagogical Tool to Deal With Complexity in IT Project Management

---

Regular Session

---

***Dr . Amy Connolly***<sup>1</sup>

*1. James Madison University*

The Information Systems 2002 Model Curriculum lists “Project Management and Practice” which includes mastery of the “management of behavioral and technical aspects of the project” [1, p. 31]. The behavioral aspects of a project are tacit or “soft” in nature and generally difficult for students to master from listening to lecture [3]. When asked to perform project management tasks first learned from reading or lectures, students’ first response is “I don’t know what to do or how to do it.” Furthermore, today’s projects continue to increase in complexity and ambiguity, demanding higher levels of critical judgment and improvisation due to their social- and context-dependent nature [2]. In response to these industry needs, I designed roleplaying exercises for the IT project management course. While roleplay exercises are commonly used for training in industry settings, they are less often applied to the IS classroom. What makes these roleplay exercises unique is that they do not involve pairs of students or small isolated groups; rather, the roleplay exercises engage the entire class simultaneously. Novices, in general, are uncomfortable with ambiguity, but an effective project manager deals with ambiguity on a daily basis. Therefore, it is paramount that project management classes subject students to such feelings of ambiguity. The active learning exercises I designed encourage students to embrace ambiguity and complexity and to practice applying project management concepts learned in class, which can improve students’ understanding, communication skills and emotional intelligence. I have used these exercises every fall and spring semester to teach IT project management for the past 5 years. Students report that the exercises help them to better deal with other people on a project and they make the course more enjoyable and the material easier to understand.

---

# Student Perceptions of Effective Teaching Methods in an Undergraduate Business School: A Proposed Framework

---

Regular Session

---

*Dr . Christie Chen <sup>1</sup>, Dr . Taeuk Kang <sup>1</sup>, Dr . Kevin Hammond <sup>1</sup>, Dr . Bonnie Daniel <sup>1</sup>*

*1. University of Tennessee at Martin*

Some observers have questioned whether institutions of higher education are preparing students in developing employability skills. For the Scholarship of Teaching and Learning (SoTL) to be recognized as crucial intellectual work, faculty must connect theory-based teaching to experience-based learning by continually developing instructional design, pedagogy, and the broader curriculum. Among business schools, efforts are being made to improve curricula by integrating traditional classroom learning and workplace experiential learning. Meanwhile, some concerns have been raised whether traditional assessments actually reflect students' knowledge and skill development (Azevdo et al., 2012). Williams and Williams (2011) identified several key elements which impact students' motivation by improving student learning outcomes. Specifically, challenging assignments (e.g. problem-solving activities or realistic business scenarios) enrich and build students' competency in content learning. Likewise, learners can be motivated through hands-on techniques such as simulations, casework, group projects/presentation and guided discussions. The purpose of this study is to provide a framework for evaluating various classroom practices and the effects on student learning outcomes. For this present study, we surveyed graduating seniors at our institution regarding the types of classroom practices and teaching methods which they had experienced over the previous twelve months, such as group presentations, computer assignments, textbook-based lectures, lecture from other sources, class discussion/debates, "real-world" speakers, brief in-class group projects, practical application of knowledge in a lab setting, service learning, etc. Based on Exploratory Factor Analysis of the data, four components were extracted to provide four dimensions of teaching and learning elements



## Student Success and Learning through Student Affairs

---

Oral

---

***Dr . Linda Champion*** <sup>1</sup>

*1. East Carolina University*

As researchers, managers, and instructors we look for verification that learning has, in fact, occurred. Our metrics include observations, test results, training and others. Disseminating knowledge also takes various forms, the Socratic method, lectures, online training and instruction. How do we know which method is best? And how do we measure if learning has occurred? Are there measures outside of the classroom that also add to or influence student learning? Linda Champion will discuss student learning through a Student Affairs model utilized at East Carolina University. The Student Success Continuum: Connect, Invest, Motivate, and Finish Strong.

# TEACHING INTRODUCTORY DATABASE: FOCUSING ON THE USER PERSPECTIVE

---

Regular Session

---

***Dr . Leigh Mutchler***<sup>1</sup>

*1. James Madison University*

A basic understanding and appreciation of databases is important to all business students. Relational database concepts are often covered within an introductory Information Systems (IS) course, a course frequently included as part of the business core and as such one that addresses the database knowledge needs of not just IS students but of all college of business majors. This abstract represents a work in progress that argues that when introductory database concepts are taught to all business majors, the focus should be from the database user perspective.

Database data retrieval and reporting skills are more important to database professionals than are the skills of designing or building [1]; therefore, the coverage of introductory database concepts in an introductory IS course should focus on query development. The course will include coverage of relational database concepts and structures, and ideally will also include hands-on activities because they contribute to learning [2] which is particularly important when learning about technologies. The active learning techniques that accompany introductory database concepts often consists of designing and building a relational database (usually with Microsoft Access), followed by simple query, report, and form development. Those majoring in IS will find these activities particularly meaningful and relevant to their future careers, but is that equally true for the non-IS student? Business students other than those majoring in IS are not expected to have a career where they will design and build a database. They will, however, have a career where they will regularly *use* a database. The greatest benefit for all business majors, including IS majors, is to learn to translate business questions into database queries which will in turn help them to more fully understand and appreciate the relational database. These activities will also aid students in the development of problem solving skills and increase understanding of business processes. The goals of this work in progress include documenting the teaching method, sample assignments, and collecting and presenting evidence of student perceptions.

# TEACHING THE IMPACT OF SUPPLY CHAIN ON PROJECT MANAGEMENT: AN EXPERIENTIAL EXERCISE AT A VINTAGE PORSCHE RESTORATION SHOP

---

Regular Session

---

***Dr . William Ritchie <sup>1</sup>, Mr . Cole Scrogam <sup>2</sup>, Mr . Noah Salvato <sup>1</sup>, Dr . Ali Shahzaad <sup>1</sup>***

*1. James Madison University , 2. Madison Automotive Apprentices Program*

Students in traditional business programs often engage in some form of project management (PM) course whereby students learn the intricacies of working with popular PM software platforms. However, associated PM software platform exercises often focus on analysis techniques using static data. In these situations, it is difficult for students to comprehend the complex nature of executing their project management plans in the “real world.” This experiential case study is designed to provide students with first-hand knowledge regarding the highly volatile relationship between supply chain efficiency and PM. In this experiential exercise, students review a brief case-study of Madison Automotive Apprentices Program (MAAP), a nonprofit corporation engaged in restoring vintage Porsches. After studying the traditional project management documents in the classroom, students then engage in a site visit to MAAP and participate in question and answer sessions with the founder and CEO to learn about supply chain challenges that impact PM implementation. This exercise illustrates how local firms in the automotive industry serve as an ideal teaching context for integrating complex concepts such as supply chain and PM.

## Television? Is It Worth Watching?

---

Regular Session

---

***Dr . Sara Kiser*** <sup>1</sup>

*1. Alabama State University*

The use of reality television in the classroom is not new. *Survivor* has been utilized to study economics and strategy; while *The Apprentice* was used to discuss every topic covered in a business curriculum. However, in recent years, there has been a myriad of new business programming. *Shark Tank*, *The Profit*, and *Undercover Boss* are some of the options which can be utilized. Outside of those “business-oriented” options, there are others such as *Brain Games* and *Mysteries at the Museum*. This presentation and subsequent paper will examine how to use a variety of these shows to bring textbook topics to “life” for students.

# The Alumni Project: Fostering Student-Alumni Engagement in the Curriculum

---

Workshop

---

***Dr . Carl Larsson*** <sup>1</sup>, ***Dr . Brooks Marshall*** <sup>2</sup>, ***Dr . William Ritchie*** <sup>3</sup>

*1. James Madison University , 2. James Madison University - Professor Emeritus , 3. J*

This workshop will present a novel approach towards fostering student-alumni engagement in the business school curriculum: the Alumni Project. Workshop attendees will learn about project details, best-practices, and explore learning outcomes based on empirical research.

The Alumni Project involves matching groups of students with alumni for a series of semi-structured interviews. Student groups produce a written report and give a 5 minute in-class presentation on their experience. Each student also completes an individual reflection paper. The primary goals of the assignment are to observe how class concepts are applied in practice, and explore careers within their discipline of study. We empirically verify the benefits of the project by using factor analysis to examine a survey instrument given to student participants after completion of the project. We find that students report (1) growth in interview skills, (2) improved career discernment, (3) a better understanding of how coursework can be applied in practice, and (4) an overall increase in learning retention.

# The Business Case for Diversity and Inclusion Education in B-Schools: Understanding the Value Proposition

---

Regular Session

---

***Dr . Deborah Hazzard*** <sup>1</sup>

*1. University of South Carolina*

Diversity and inclusion (D&I) is no longer just a moral or ethical argument, it has become a strategic business imperative for successful companies. With semi-globalization and super-diversity the world has become increasingly complex for multinationals to navigate. Furthermore, a more diverse and multicultural environment, the current demographic shift and the presence of multiple generations in the workplace and consumption-scape, has made the development of diversity and inclusion strategies a key focus for many multinational companies. Research suggests that diverse and inclusive firms differ from other firms in a number of ways, including: greater innovation, enhanced creativity, higher productivity, heightened levels of profitability and increased employee engagement. We believe that business students must be knowledgeable about D&I, and its role as a transversal function in organization structure. At the same time, students need to understand the dimensions of diversity, and be capable of creating strategic plans to move D&I forward in organizations. These competencies give business students at the Darla Moore School of Business a distinct competitive advantage relative to their peers.

Without question, diversity and inclusion competencies are becoming more important given current political, economic, social and demographic considerations. Capable and qualified people (regardless of their race, ethnicity, gender, social class etc.) must be at the table—inside of organizations in management positions, on corporate leadership teams and in corporate board rooms. And their insights and perspectives should be leveraged and utilized to inform decision making processes. As previously stated, diverse perspectives lead to better decisions and superior performance.

Several studies show that diverse and inclusive organizations are characterized by superior business performance and enhanced innovation and creativity. At the same time, organizations are actively seeking to integrate functionally qualified people into their firms, who possess diversity and inclusion competencies, in order to move the needle forward from a strategic perspective. For these reasons, business students need to be steeped in diversity and inclusion content and have key insights about the practical application of D&I in the workplace. During this interactive and engaging session, we will explore the value proposition relative to D&I education in B-Schools.

# The Impact of Being a Procrastinator on Academic Success: A Case Study in an Online Learning Environment

---

Regular Session

---

*Ms . Tarakci, Yasemin <sup>1</sup>, Dr . Hakan Tarakci <sup>1</sup>*

*1. University of North Texas*

In this paper, we study the performance of students enrolled in a fully online class. We define procrastinators as those who submit their exam within the last 5% of the allotted time. Our findings show that there is a significant difference between the academic performance of the procrastinators and the “punctuals”: procrastinators’ exam scores are significantly lower than those of the punctuals. We also share these results with the entire class of almost 200 students through an online announcement on the class website. Our follow-up analysis shows that the proportion of procrastinators decreases; in addition, the performance of procrastinator-cum-punctuals improves significantly.

# The Importance of Faculty Engagement in Online Courses

---

Regular Session

---

***Dr . Colleen Carraher Wolverton <sup>1</sup>, Dr . Zhiwei Zhu <sup>1</sup>***

*1. University of Louisiana at Lafayette*

This study examines the relationships between faculty engagement and intention to teach online courses. Much research has focused on factors relating to student engagement, although we posit that faculty engagement represents an important aspect in the online education context that has been fairly overlooked in the engagement research stream. Therefore, in this study, we seek to not only understand the factors that influence faculty's intention to teach online courses but also an instructor's level of faculty engagement in online courses. We sought a novel lens with which to examine this phenomenon, so this study utilizes the perceived characteristics of innovation (PCI) to examine the relationships between faculty engagement and intention to teach online courses. A survey of 99 instructors from a large public university was conducted. Structural equation modeling was employed to analyze the data, concluding that result demonstration, relative advantage, and compatibility influence a faculty's level of engagement in an online course, which in turn influences their intention to teach an online course. These findings have important implications for higher education online course offerings, as the demand for online courses has been increasing and we must ensure we have engaged faculty to teach these courses. This study extends PCI and provides valuable insights into how to encourage and motivate more instructors to be involved in online teaching.



# THE VALUE OF CASE COMPETITIONS AND THEIR INTANGIBLE BENEFITS

---

Regular Session

---

***Dr . Gwen Hanks <sup>1</sup>, Dr . Mario Zaino <sup>2</sup>, Dr . Sara Kiser <sup>2</sup>***

*1. Innovative Business Solutions , 2. Alabama State University*

*In recent years, case competitions have grown from niche activities at some universities to promote their brand into international events embraced by multinational corporations in search of future talent. The case method has been a valuable teaching method in many disciplines. Cases represent enhanced experiential learning tools designed to involve students as decision-makers in the application of relevant concepts to real situations, problems, and challenges through active analysis. In many situations, cases and case competitions add something intangible that students can engage with, while enhancing their world view. The added-value for business school students is that participants learn and apply skills that can be utilized for problem-solving and decision-making in the “real world.” Many benefits are acquired via this active learning method, some visible, others less tangible but just as valuable. This article reviews case competitions as valuable global events useful to multiple constituencies, such as faculty members, students, researchers and corporate sponsors, and business schools (as a measure of assurance of learning) all intent on deriving rewards from these events. The authors present exploratory research and an overview of opportunities to showcase student through the evolving skills and benefits associated with case competitions.*

# Underrepresented student populations in an IT program: Successes and Failures

---

Regular Session

---

***Dr . Elizabeth Rasnick <sup>1</sup>, Dr . Chris Kadlec <sup>1</sup>***

*1. Georgia Southern University*

In an undergraduate program in Information Technology, success in achieving a proportional representation between racial groups has been sustained for many years. This has been achieved with little extra effort to recruit racial minorities. In contrast, there is a woefully disproportionate number of females to males in these same classes. The women in these classes are high achievers and recognized with scholarships and competition wins beyond the university campus. The faculty are struggling to understand how we are effortlessly succeeding with one underrepresented group and dismally failing in another.

To determine how we have arrived at these population distributions, we look at the demographics of our current students and recent alumni. We use a survey to collect the influencing factors and reasons why students choose Information Technology as a major. Subjects are also asked about any obstacles they faced and what support that helped them overcome those difficulties. They are asked directly about the formal and informal support mechanisms that exist on our campuses. The drive behind this research is to determine what we, as faculty, can do to recruit and retain more female students in information technology. A secondary result may be to seek additional funding for informal support mechanisms that are proving to be important to underrepresented student populations.

# UNPACKING NEW GEOSPATIAL TOOLS FOR SUPPLY CHAIN PEDAGOGY, PRACTICE, AND RESEARCH

---

Workshop

---

***Dr . William Ritchie <sup>1</sup>, Dr . Joseph Kerski <sup>2</sup>***

*1. James Madison University , 2. ESRI, Inc*

Supply chain management (SCM) is a dynamic and continually evolving field in terms of pedagogies, technology, and practice. This rapidly changing environment calls for supply chain educators and practitioners to remain current on the latest technologies, particularly those that integrate functions across business disciplines. One such integrative technology is location analysis. Software such as Tableau, Power BI, and Google Maps have rapidly diffused into the marketplace, bringing about new methods of analyzing and displaying supply chain data that incorporates the location component. Foundational to these technologies is geographic information systems (GIS). The purpose of this workshop is to share recent developments involving GIS and its application in supply chain practice, pedagogy, and research.

**Innovative Education,  
Assessment, Engaged  
Learning, Curriculum,  
Teaching and Pedagogy -  
Papers**

## **A STUDY ON SOCIAL PRESENCE AND GENDER IN ONLINE LEARNING**

ChongWoo Park, Hull College of Business, Augusta University, 1120 15<sup>th</sup> Street, Augusta, GA  
30912, 706-729-2351, chopark@augusta.edu

Dong-gook Kim, Wright School of Business, Dalton State College, 650 College Drive, Dalton,  
GA 30720, 706-272-2041, dkim@daltonstate.edu

### **ABSTRACT**

While online classes become more popular in higher education, there have been challenges to students' learning experience in online learning. One critical challenge would be providing interactions between students and instructors as good or effective as in the face-to-face learning. Prior research on student success in online college courses has pointed out that the interactions between students, their peers, and their professors in online courses are different from those in face-to-face courses. Students may perceive the lack of interactions in online courses because instructors and peer students are not physically present together. Such lack of interactions due to no physical presence may negatively affect student performance in online learning. In this study, we introduce social presence in online learning as an alternative to physical presence in the face-to-face learning, and investigate the role of social presence as student learning experience in online learning. While gender difference has been studied in traditional face-to-face learning, there have been few empirical studies on gender difference in online learning, whose results are often contradictory. In addition, there has been little research that investigates the effect of gender difference on social presence in online learning. In this study, we also attempt to examine the role of gender difference in building social presence in online learning. Thus, we pose the following research questions.

How can we promote social presence in online learning?

What is the role of gender difference in establishing social presence in online learning?

In answering the questions, we draw on the social presence and online learning literature, and propose a research model to explain how interactive communication tools can drive social presence and student satisfaction in online learning.

To test the research model, we collected survey data from undergraduate students who were taking online business statistics courses where an interactive communication tool was required to use for class communication and collaboration. Preliminary data analysis shows that social presence driven by tool interactivity has a significant impact on student satisfaction in online learning, in which social presence fully mediates between interactivity and satisfaction. This finding implies that not only interactive tools but any other tools or activities that can increase social presence may contribute to student satisfaction in online learning. Thus, educators may be able to take advantage of this finding by employing a tool or an activity to help students build higher social presence in online learning. Our results also show that gender difference moderates the relationship between interactivity and social presence in online learning.

## **DETERMINANTS OF PERFORMANCE OUTCOMES IN BUSINESS SIMULATIONS USING KOLB'S LSI**

Robert Hasbrouck, Luter School of Business, Christopher Newport University, 1 Avenue of the Arts, Newport News, VA 23606, (757) 594-7265, rhasbro@cnu.edu

Scott Walker, Luter School of Business, Christopher Newport University, 1 Avenue of the Arts, Newport News, VA 23606, (757) 594-8915, scott.walker@cnu.edu

### **ABSTRACT**

The use of experiential learning-based assignments and projects in higher education has been well cited as a positive way to improve learning (Kolb and Kolb, 2005; Trautrim et. al., 2016, 2000; Xu and Yang, 2010, and many others). The Experiential Learning Theory (ELT) posits that new experiences create new knowledge and understanding through the interaction of acquisition and transformation (Kayes, 2002). Much of the recent literature uses Kolb's Learning Style Inventory (LSI) survey to support the tenets of the experiential learning process (Hawk and Shah, 2007; Kamis and Kahn, 2009; Peterson and Kolb, 2018).. Although there are a limited number of studies that compare learning styles to performance (Armstrong and Mahund, 2008), the use of Kolb's LSI as a predictor or identifier of student performance has yet to be examined. In this paper we examine student performance in a business simulation and compare the results to the LSI profile to determine the relationship between learning style and simulation performance. Specifically, we are interested in the following research questions;

- 1) Simulation Performance: Are there performance differences between the LSI constructs (CE – concrete experience, RO – reflective observation, AC – abstract conceptualization, AE – active experimentation, CE-AC and AE-RO)?
- 2) Student Major: Does one's business major favor one of the Kolb LSI constructs?
- 3) Gender and simulation outcome: Does gender play a role in selection of the LSI constructs? Is gender a factor in simulation performance?

The preliminary results indicate a pattern of performance within the Kolb profiles and suggests that student performance can be influenced by additional factors including major and gender, which has been reported in a prior study (Garber, et.al., 2017). The authors invite those who use, or are considering the use of, business simulations in their pedagogy to collaborate in this study to expand scope of the initial research findings.

## Enhancing CIS Program Curriculum with Certifications

### **DECISION SCIENCES INSTITUTE** Enhancing CIS Program Curriculum with Certifications

#### **Authors**

Jewett, James W., Lecturer, James Madison University, 800 South Main Street, Harrisonburg, VA 22807, [jewettjw@jmu.edu](mailto:jewettjw@jmu.edu), 540 568-3059.

Dillon, Thomas W., Professor, James Madison University, 800 South Main Street, Harrisonburg, VA 22807, [dillontw@jmu.edu](mailto:dillontw@jmu.edu), 540 568-3015.

Crouch, Joseph Austin, Graduate, James Madison University, 800 South Main Street, Harrisonburg, VA 22807, [crouchja@dukes.jmu.edu](mailto:crouchja@dukes.jmu.edu).

#### **ABSTRACT**

The purpose of this study was to assess the current views of employers in the IT field with regard to IT certifications for entry-level employees. A literature review was completed as well as a survey project which investigated the opinions of major employers of James Madison University Computer Information System graduates. Employers value perspective entry-level employees with these certifications as well as encourage and support current employees to obtain them. Preparing CIS degree program students for the more valuable technology certifications is a desirable goal which would lead program faculty to introduce/improve courses that support students' efforts to obtain certifications.

**KEYWORDS:** Certifications, CIS curriculum

#### **INTRODUCTION**

According to the Bureau of Labor Statistics, employment of computer and information technology occupations is projected to grow 12 percent from 2018 to 2028 (BLS, 2019). By comparison, the average of all other occupations is projected to grow at just 7 percent. So, technology-driven occupations are projected to grow at a much faster rate than the average for all occupations. These technology-driven occupations are projected to add about 546,200 new jobs in the U.S. And, according to the BLS, the demand for these workers will be driven by a need for knowledge in cloud computing, the collection and storage of big data, and information security.

Graduates of technology-driven academic majors, such as computer information systems, computer science, and information technology are often not prepared to meet these entry-level employment needs upon graduation. These graduates must be equipped with the skills to fill the open technology-driven positions. The difference between the preparedness for immediate hire into these entry-level positions and the skills that graduates have is known as the Skills Gap (Schartz, 2019; Restuccia et al., 2018).

To reduce the Skills Gap, universities take many steps. For example, they may introduce programs that attempt to increase the number of students attracted to technology-driven college

## Enhancing CIS Program Curriculum with Certifications

majors by providing “early in the pipeline” education for middle and high school students (Brookshire et al., 2008; Dillon et al., 2016). And, they may utilize experiential learning simulations (Vandsburger et al., 2012), capstone software development projects that engage with real customers (Cole et al., 2018) or bring professionals into the classroom to serve as mentors (Dillon & Lending, 2014). Though all these programs may reduce the Skills Gap for technology-driven majors, we propose that a more direct method is to integrate the skills directly into the academic curriculum that employers most desire.

One of the highest desires of employers is to hire entry-level employees into IT-based positions that have previous experience with the tools, techniques, or technologies used in the work place (Harris et al., 2012; Wierschem & Mediavilla, 2018). To meet the employer desires directly we propose preparing graduates with certifications in technology domains such as cloud computing, networking, and software design, among others.

### REVIEW OF LITERATURE

#### Academic Major Preparation

As of 2019, The Bureau of Labor Statistics identifies seven general technology-driven occupations that require a bachelor’s degree. These include: computer network architects, computer programmers, computer systems analysts, database administrators, information security analysts, network and computer systems administrators, and software developers (BLS, 2019). And, though knowledge of cloud computing is considered a driving factor for growth in technology-driven occupations, there is no mention of cloud architects yet in the occupations list. Of these seven technology-driven occupations that require a bachelor’s degree, information security analyst is the fastest growing, with a predicted 32 percent growth by 2028.

In addition to the desire for high academic performance (Tabatabaei & Gariner, 2012), recent research by Wierschem & Mediavilla (2018) determined that employers place an emphasis on three areas of preparation for entry-level employment; experience with the tool, technique, or technology, an academic degree in the proper field, and certifications in technology domains. Each of these desires may be achieved while pursuing a bachelor’s degree in a technology-driven major.

Experience with a tool, technique, or technology may be gained during academic preparation through activities such as classroom instruction, internships, experiential learning, capstone course projects and student employment (Schartz, 2019).

Many companies now provide internships, both in the summer and during the academic year, for technology-driven majors. Students often report great satisfaction with internship experiences (Jaradat, 2017). Though not always a requirement for an academic major, most colleges and university encourage participating in internship programs and form alliances with local and regional employers to provide this option. Internships may be taken for credit, or without credit, there does not appear to be a consistent preference by major or university.

Experiential learning opportunities may be totally classroom based with simulations or other creative learning activities (Vandsburger et al., 2012), or they may involve outside actors that provide a real-world project, mentoring, or engaged learning venture (Dillon & Lending, 2014). The key to success is to provide what is needed for the students involved to gain an experience



## Enhancing CIS Program Curriculum with Certifications

that relates to real-world work. This experience allows the students to draw real-world comparisons.

A capstone or culminating project course is another option that allows students to gain applicable experience, especially if the capstone project course has a real project offered by a real client (Cole et al., 2018). A common goal of the capstone instructor is to locate a non-profit or small business that desires a new system or prototype. Since the capstone is most often a curriculum integrating course, the new system often needs a software application, database model, and connectivity. The size and scope of the project allows the students to work in teams, gather system requirements from a real client and development an actual product.

Student employment on campus or in the local community is also a beneficial way to provide work experience (Perozzi, 2009). Research shows that student learning may be enhanced through employment. Entry-level work experience on a college or university campus may be obtained by serving on the university help-desk. In addition, work can often be found in computer labs, network installations, website development or content management activities, or application development and support.

Standard classroom instruction often involves the introduction of a tool, technique or technology to supplement the conceptual content. To facilitate the use of software tools, most major vendors, such as Microsoft ([azure.microsoft.com](https://azure.microsoft.com)), Oracle ([academy.oracle.com](https://academy.oracle.com)) and Cisco ([cisco.com](https://cisco.com)) have academic programs that provide the tool or technology to be used in the classroom for a reduced price. It is not uncommon for a course in database to be taught in one or more database environments, or a course in network management to be specific to Cisco products.

Employers seek employees that have experience with the tools, techniques, and technologies, an earned academic degree, and certifications in technology domains. University academic programs could decide to differentiate their program by incorporating the completion of certifications into their technology-driven majors (Schartz, 2019). Considering that vendors already provide reduced price platforms for their products, this is not an unreasonable goal.

### **Technology-Driven Certifications**

Technology-driven certifications provide employers with the skilled personnel they need in order to operate effectively. Certifications provide potential employees with more confidence, self-efficacy, and a sense of inclusion (Brooks et al., 2011). In addition, professionals that have previously earned technology certifications, are more likely to continue learning new skills (Lohman, 2009). It is now common for employers to base job requirements on certifications and experience (Hunsinger et al., 2011) and provide higher salaries for those that are certified. Up to 85% of employers now prefer graduates or potential hires to possess at least one certification beyond a possible degree in information technology (Hunsinger & Smith, 2009). In 2015, Wright estimated that 23% of all IT positions now require a certification. Also, professionals with certifications are more likely to value the skills of other with certifications (Messmer et al., 2011). As more professionals obtain certifications, the demand for certifications may then increase at a faster rate.

While some academic programs currently offer technology-driven certifications in their programs, other computer science, information technology, and information systems programs may want to consider providing a pathway for obtaining certifications into their current curriculum (Daniels, 2011). Each academic program would need to choose the likely

## Enhancing CIS Program Curriculum with Certifications

certification programs that best fit their environment, considering the expense, the overhead, and the fit with current or future curriculum (Krutchen, 2010). The overall expense of incorporating a technology-driven certification into an academic program can vary greatly and is typically negotiated between the vendor and the university. For example, faculty may need to be trained or certified with specific equipment or software, specialized lab equipment may need to be purchased, a testing center may need to be created, membership fees paid to organizations for vendor managed groups, and each individual exam completed by the students in the program may be a cost for consideration.

Many technology-driven certifications provide academies (such as Microsoft ([azure.microsoft.com](https://azure.microsoft.com)), Oracle ([academy.oracle.com](https://academy.oracle.com)) and Cisco ([cisco.com](https://cisco.com))) or academic membership programs. The type of certification offered is important. It will influence how the university or college promotes the program and will determine the value-added to the academic program.

The requirement and desirability of graduates to have technology-driven certifications as well as bachelor's degrees is further complicated by the additional desire for soft-skills, or non-technical skills (Bailey, 2014; Ezell et al., 2019). But, this desire may be met with the introduction of certifications in non-technical areas, such as project management ([www.pmi.org](https://www.pmi.org)) and scrum ([www.scrumalliance.org](https://www.scrumalliance.org)).

### METHODOLOGY

The research into relevant certifications began with a review of the pertinent literature. This research was augmented by a survey of our university alumni from the Computer Information Systems program and employers of our graduates. Our university sits just two hours from the Washington D.C metropolitan area, three hours from Baltimore, Maryland and five hours from Philadelphia, Pennsylvania.

The survey was distributed via email to approximately seven hundred individuals with over seventy returned. The data received from the survey was analyzed to determine the most valuable certifications in the IT industry today and their effect on the employment the individual professionals who possess them.

The survey of graduates and employers was targeted towards four specific career tracks: consulting, Cybersecurity, Business Analytics and Cloud/server management. Persons surveyed in each specialized track were asked to identify and rank IT certifications that were of most value to professionals in each track, respectively. Survey respondents were also asked about the role that certifications in general play in their professions.

### FINDINGS

#### Consulting Track Certifications

Responses in the Consulting track identified three dominant certifications of value: Project Management Professional or PMP, Certified Scrum Master or CSM and Certified Information Systems Auditor or CISA. PMP was identified by 37% of respondents while Certified Scrum Master and Certified Information Systems Auditor were identified by 23% of respondents each, respectively. Other certifications such as Microsoft Office Certifications, Oracle Certifications and AWS Certifications were also mentioned to a lesser degree. Many respondents stated that

## Enhancing CIS Program Curriculum with Certifications

since the field of consulting is generalized by nature, any technical certification will help differentiate a job candidate in this field. One comment received advised that a professional's experience as a consultant may lead that person to pursue certain specialized areas of IT certifications.

### **Cybersecurity Track Certifications**

Responses to the Cybersecurity track identified two dominant certifications of value: Certified Information Systems Security Professional or CISSP and the Comptia Security+ certification. CISSP was identified by 51% of respondents while Security+ was identified by 16%. Other certifications mentioned were PMP, AWS, Certified Ethical Hacker or CEH, CISA and certified Information Security Manager or CISM. From the responses, the CISSP certification appears to be the certification of most value to professionals in the Cybersecurity field.

### **Business Analytics Track Certifications**

There was no certification that had a significant identification by professionals in the Business Analytics track. Many certifications were listed, but usually by only one or two respondents. The certifications mentioned either related to project management such as CSM and PMP or individual software tools such as Anaplan or Tableau. Certifications do not appear to provide specific credentialing or value to professionals in this track. This could be because of the newness of the content.

### **Cloud/Server Management Track Certifications**

The responses in this track were of little surprise. Seventy five percent (75%) of respondents identified the AWS Certification as one of value to professionals in cloud services. Respondents identified Microsoft Azure Certification and Google Cloud Certification at 17% and 8%, respectively. Amazon Web Services or AWS controls over 34% of the cloud market while Microsoft Azure, AWS's closest competitor, controls about 11%. Of the 70 respondents, six of them had the AWS Certification themselves and all respondents collectively mentioned the AWS certification over 60 times. A recent Global Knowledge Survey found that an employee earning an AWS certification received as much as a 25.9% increase in salary. Individuals who possessed the AWS certification earned an average of \$113,932 while individuals without the certification earned \$90,512. Clearly, the AWS certification is of high value in this track.

### **General Responses on Certifications**

There were responses that offered additional insights into the value of certifications. First, respondents were asked if any major certifications were no longer of value in today's professional environment. The respondents stated that no major IT certifications were obsolete to their knowledge. Other major points summarized from the responses to the survey are:

1. Work experience is more valued, but certifications are more quantifiable.
2. Certifications are valuable for professional development and promotions during one's career.
3. Certifications should be related to your field of interest and employment.
4. Certifications definitely help to differentiate job candidates.

### **Employer Incentives Related to Certifications**

Respondents indicated that 92% of employers in their situations offer incentives for employees earning IT certifications. Some of the most common incentives are:

1. Bonus per certification

## Enhancing CIS Program Curriculum with Certifications

2. Overtime paid for certification training
3. Raises resulting from certification obtainment
4. Reimbursement for certification testing costs
5. Reimbursement for certification training materials.

### **CONCLUSIONS AND RELATED TO PROGRAM IMPROVEMENTS**

The CIS program at our university provides breadth and depth in IT knowledge and training. This includes instruction and mastery in programming, databases, telecommunications and systems development. In addition, we provide a course that provides instruction directly related to the Amazon Web Services certification. This course, currently only one credit, could be expanded to three credits to provide more comprehensive instruction in AWS. The telecommunications course presents foundation topics from the Comptia Network+ certification while the advanced programming elective course presents foundation topics from the Cisco CCNA certification. The courses in enterprise architecture, systems analysis and the system development (capstone) courses provide solid foundations in systems development and project management concepts that are the basis of the PMP and CSM certifications. Based upon the current CIS program and the findings of this research, listed below are some possible enhancements we are considering to our CIS program:

1. Increase the credit hours in CIS 301 from 1 to 3 credits.
2. Evaluate all CIS courses for relevant industry content needs related to certifications listed in this report.
3. Create 'boot camp' 1-3 credit courses to prepare students for high value industry certifications.

### **Summary**

The case for providing the opportunity for computer technology focused degree program students to gain IT certifications is supported by the relevant literature and James Madison University's Department of Computer Information Systems and Business Analytics' survey. Such a program would help to alleviate the shortage for IT professionals for our employers (BLS, 2019) while simultaneously addressing the identified skills gap in current entry-level IT workers (Schartz 2019, Restuccia, Taska & Bittle, 2018).

In concurrence with the literature, our research indicated that employers valued IT certifications for perspective employees (Hunsinger & Smith, 2009). Which boosts employment and salary prospects for job candidates. Our survey revealed that employers view certifications as a quantifiable measure of job candidate skills and clearly differentiate job candidates. Our results identified PMP, CSM, CISSP and AWS as being the most desirable certifications.

In light of our employer survey desiring graduates with IT certifications and findings of relevant literature, The CIS program at JMU should develop and modify courses in the CIS curriculum to prepare students for the employer preferred IT certifications (Krutchen, 2010). This would include PMP, CSM, CISSP and AWS certifications. Part of an effective program would entail the need for faculty to obtain such certifications themselves. Several JMU CIS faculty have attained and maintain IT certifications such as AWS, CSM and Network+. Professional development programs and funding should be provided for faculty who wish to become certified in their area of expertise. Complementing our academic degree program with specific technical tools and

## Enhancing CIS Program Curriculum with Certifications

skills resultant from the focus on certification areas of expertise, our program can help close the noted 'skills gap' (Schartz, 2019). As indicated by our employer survey, developing supporting curricula in our CIS program to enable our students to attain AWS, CSM, PMP, and CISSP certifications would be the effective strategy to address the certification aspects of our program.

Enhancing CIS Program Curriculum with Certifications

**REFERENCES**

<https://academy.oracle.com/en/oa-educator.html>

<https://azure.microsoft.com/en-us/education/>

Bailey, J. L. (2014). Non-technical skills for success in a technical world. *International Journal of Business and Social Science*, 5(4). <http://www.ijbssnet.com/>

Brooks, N. G., Riemenschneider, C. K., Hardgrave, B. C., & O'leary-Kelly, A.M. (2011). IT professional identity: Needs, perceptions, and belonging. *European Journal of Information Systems*, 20(1), 87-102. <http://www.palgrave-journals.com/ejis/index.html>

Brookshire, R.G., Kemp, K., Thomas, D.M. & Dillon, T.W. (2008) High school computer camps: an "early in the pipeline" step to meet the demand for diverse information technology workers, *Proceedings of the 2008 ACM SIGMIS CPR Conference*.

Bureau of Labor Statistics (BLS). (2019). Online. Available: <https://www.bls.gov/>

Cole, C., Boehmer, D., Dillon, T.W., & Lending, D., (2018) Patterns of Requirements Gathering for a CIS Capstone Course, *Twenty-fourth Americas Conference on Information Systems*, New Orleans, 2018.

<https://www.cisco.com/c/en/us/training-events/cisco-networking-academy/regional-sites/us-canada/schools-instructors.html>

CompTIA. (2012). *State of the IT Skills Gap, Full Report*. Online. Retrieved from <http://www.comptia.org>.

Daniels, V. S. (2011). Assessing the value of certification preparation programs in higher education. *American Journal of Business Education*, 4(6), 1-10. <http://journals.cluteonline.com/index.php/AJBE>

Dillon, T.W. & Lending, D. (2014) Using professional consultants to mentor CIS students on a simulated consulting project, *Proceedings of the 52nd ACM conference on Computers and people research*, 171-175.

Dillon, T.W., Reif, H. L. & Thomas, D.S. (2016) An ROI Comparison of Initiatives Designed to Attract Diverse Students to Technology Careers. *Journal of Information Systems Education*, 27(2), 105-117.

JD Ezell, D Lending, TW Dillon, J May, CA Hurney, KH Fulcher (2019) Developing Measurable Cross-Departmental Learning Objectives for Requirements Elicitation in an Information Systems Curriculum, *Journal of Information Systems Education* 30 (1), 27-41.

Harris, A. H., Greer, T. H., Morris, S. A., & Clark, W. J. (2012). Information systems job market late 1970's – early 2010's. *The Journal of Computer Information Systems*, 53(1), 72-79. <http://www.iacis.org/jcis/jcis.php>

## Enhancing CIS Program Curriculum with Certifications

- Hunsinger, D. S. & Smith, M. A. (2009). IT certification use by hiring personnel. *The Journal of Computer Information Systems*, 50(2), 71-82. <http://www.iacis.org/jcis/jcis.php>
- Hunsinger, D. S., Smith, M. A., & Winter, S. J. (2011). A framework of the use of certifications by hiring personnel in IT hiring decisions. *Database for Advances in Information Systems*, 42(1), 9-28,6. <http://www.sigmis.org/DataBase.html>
- Jaradat, G.M. (2017) Internship training in computer science: Exploring student satisfaction levels, *Evaluation and Program Planning*, 63, 109-115
- Kruchten, P. (2010). Certification 1, 2, 3. *IEEE Software*, 27(3), 92-94. <http://www.computer.org/portal/web/computingnow/software>
- Lohman, M. C. (2009). A survey of factors influencing the engagement of information technology professionals in informal learning activities. *Information Technology, Learning, and Performance Journal*, 25(1), 43-53. <http://www.edilib.org/j/ISSN-1535-1556/68>
- Messmer, P. R., Hill-Rodriguez, D., Williams, A. R., Ernst, M. E., & Tahmooressi, J. (2011). Perceived value of national certification for pediatric nurses. *The Journal of Continuing Education in Nursing*, 42(9), 421-432. <http://www.healio.com/journals/jcen>
- Perozzi, B. (Ed.). (2009). *Enhancing student learning through college employment*. Bloomington, IN: Association of College Unions International.
- Project Management Institute. (2019). Online. Available: <https://www.pmi.org/certifications/types/project-management-pmp>
- Restuccia D., Taska B. & Bittle, S. (2018). *Different skills, Different Gaps. Measuring & Closing the Skills Gap*. U.S. Chamber of Commerce Foundation and Burning Glass Technologies.
- Schartz, S. (2019) Identifying high demand information technology certifications that synergize with academic programs, *Journal of Research in Business Information Systems*, 11(11), 48-69.
- <https://www.scrumalliance.org/get-certified>
- Tabatabaei, M., & Gardiner, A. (2012). Recruiters' perceptions of information systems graduates with traditional and online education. *Journal of Information Systems Education*, 23(2), 133-142. <http://jise.org/>
- Vandsburger, E., Duncan-Daston, R., Akerson, E. & Dillon, T.W. (2012) The Effects of Poverty Simulation, an Experiential Learning Modality, on Students' Understanding of Life in Poverty, *Journal of Teaching in Social Work* 30, 300–316.
- Wierschem, D. & Mediavilla, F. A. M. (2018). Entry level technology positions: No degree required. *Journal of Information Systems Education*, 29(4), 253-268.

## Enhancing CIS Program Curriculum with Certifications

Wright, M. A. (2015). Improving Cybersecurity Workforce Capacity and Capability. *ISSA Journal*, 14-20.



**GRANTS REQUIREMENT AND FACULTY PERFORMANCE ASSESSMENT AT SELECTED  
BUSINESS COLLEGES**

Kai S. Koong, Tuskegee University, 1200 W. Montgomery Road, Tuskegee, AL 36088, USA,  
334-727-8707, kkoong@tuskegee.edu

Lai C. Liu, The University of Texas - Rio Grande Valley, 1201 W. University Drive, Edinburg,  
TX 78539, USA, 956-665-3353, lai.liu@utrgv.edu

Haoyu Wen, Xidian University, 2 South Taibai Road, Xi'an, Shaanxi 710126, People's  
Republic of China, wenhaoyu@gmail.com

Yuntao Zhang, Xidian University, 2 South Taibai Road, Xi'an, Shaanxi 710126, People's  
Republic of China, ytzh\_119@sina.com

**ABSTRACT**

As corporate and governmental grant money play an increasing important role in research and service, more and more universities are expecting faculty to participate in grantsmanship. This is understandable because budgets for higher educations are getting smaller. Institutions are being asked to either do more with less or to begin doing less with less. Obviously, grants are a source that can be tapped. Using a convenient sample, this pilot study examines grantsmanship requirements and faculty performance assessment at selected business schools. In particular, this study examines the practice of grantsmanship at AACSB accredited institution as to how these sources are valued in the performance matrices. Faculty, administrators, and unions will find this study interesting.

## **HIGHER EDUCATION CAN IMPROVE EFFICIENCY, REDUCE WASTE, AND SAVE MILLIONS: SOME REMARKABLY SIMPLE CHANGES**

Hershey H. Friedman, Department of Business Management, Murray Koppelman School of Business, Brooklyn College, 2900 Bedford Avenue, Brooklyn, NY 11210, 718-951-5000, x.friedman@att.net

Taiwo Amoo, Department of Business Management, Murray Koppelman School of Business, Brooklyn College, 2900 Bedford Avenue, Brooklyn, NY 11210, 718-951-5000, tamoo@brooklyn.cuny.edu

### **ABSTRACT**

Most institutions of higher learning have a mindset that might have made sense in the industrial age but is dangerous in the knowledge economy. One researcher claims that half of the 4,000 colleges and universities in the United States will be bankrupt within the next few decades. Change is coming whether colleges and universities like it or not. Think of what is happening to the newspapers and retailers. The institutions of higher education that survive will be the ones that learn how to eliminate waste and be efficient. This paper highlights several simple changes that have the potential of saving colleges millions of dollars. These freed up resources may then be used to improve quality.

Keywords: Reducing waste in education, networking universities, merging colleges, hierarchical organizational structure, administrative bloat, silo-busting, RCM, prioritizing criteria, outcomes assessment, and academic departments.

### **INTRODUCTION**

Education is one of three crucial areas — education, public health, and the criminal justice system — where government spends an inordinate amount of money, yet outcomes remain quite disappointing. Change is coming whether colleges and universities like it or not. Just one example of change is that in the mid-1950s, 25% of all undergraduate enrollments were in liberal arts colleges; today, it is about 3 to 4% [50]. Another change is that nowadays, full-time students spend only 14 hours a week studying for their courses. Thanks to grade inflation, the average GPA for a college student is now 3.2 [9].

Does higher education have a positive impact on the United States? One would think that almost every American would answer in the affirmative to this question. In actuality, a Pew Research Center survey conducted in summer 2018 found that the majority of Americans believe that higher education is going in the wrong direction [29]. Both Democrats and Republicans are concerned about higher education but for different reasons. Democrats are more troubled than Republicans about the fact that tuition costs are too high (92% vs. 77%, resp.); Republicans are bothered by the fact that “professors are bringing their political and social views into the classroom.” (79% of Republicans vs. 17% of Democrats). The majority of Democrats and

Republicans (56% and 73%, resp.) feel that “Students are not getting the skills they need to succeed in the workplace” [29].

### AGE OF DISRUPTION

The age of disruption is discussed in [40]; and emphasizes the fact that no business is “immune from obsolescence whether those forces come from technology, globalization, or consumer-driven expectations.” The world has never seen so many rapid advances in diverse fields, and society is “evolving at an exponential rather than a linear pace.” Business models that might have worked during the industrial age will be disastrous during the Fourth Industrial Revolution [44]. Raphan and Friedman [43] state that the rules have changed; firms that want to thrive must be agile, adaptable, and not frozen in the past.

Xerox, a once formidable technology company that has been in decline is merging with Fujifilm Holdings. David B. Yoffie, a Harvard professor, had this to say: “Xerox is the poster child for monopoly technology businesses that cannot make the transition to a new generation of technology” [33]. Scholars assert that Xerox fell into the “competency trap.” This occurs when an “organization becomes so good at one thing, it can’t learn to do anything new” [33]. The same thing happened to Kodak, which went bankrupt.

The old rule books for running organizations, including colleges and universities, have to be thrown out because we are in an age of globalization, machine learning, and technological convergence. No industry can afford to be complacent. Just think of what has happened to the newspaper industry and is now happening to retailing including such formerly prevailing companies as Sears. With Amazon responsible for 4% of all retail sales in 2017 [13], many retailers are struggling. The number of retailers that are bankrupt continues to increase. So far, in 2019 (with four months to go), 15 retailers have filed for bankruptcy or liquidation [8]. The retail apocalypse continues its relentless march, and 12,000 stores are expected to close in 2019 [51]. Another industry that should prepare itself for huge changes is healthcare. It is no secret that the United States spends the most on healthcare and gets substandard results. The United States spends \$8,047 per capita (14% of GDP) on health with a life expectancy at birth of 78.7 years. Japan spends \$3,971 per capita (9.1% of GDP) on health with a life expectancy of 84.0 years [7]. It should be no surprise that many of the Democratic 2020 presidential candidates are talking about radical transformations of the industry, including Medicare for all.

Two events may have dramatic effects on the American health care industry. First, Amazon, JPMorgan Chase, and Berkshire Hathaway will be joining together to provide coverage for their own employees. They plan on using technology as a means to provide simpler and very affordable coverage for their employees. In China, technology companies such as Alibaba will be building a “hospital of the future” using artificial intelligence. This includes creating online diagnostic systems to make doctors more efficient and to provide medical advice [52].

It is only a matter of time before someone builds an efficient “university of the future.”

Unfortunately, most institutions of higher learning have a mindset that might have made sense in the industrial age but is irrelevant to the information age. Institutions of higher education may become the poster child for industries that have become fossilized despite the enormous changes in society and technology. This is what Peter Drucker said in 1997 about higher education:

Thirty years from now the big university campuses will be relics. Universities won’t survive. It’s as large a change as when we first got the printed book. Do

you realize that the cost of higher education has risen as fast as the cost of health care? And for the middle-class family, college education for their children is as much of a necessity as is medical care —without it the kids have no future. ... Such totally uncontrollable expenditures, without any visible improvement in either the content or the quality of education, means that the system is rapidly becoming untenable. Higher education is in deep crisis [42].

It is not surprising that most corporations believe that college does a poor job of preparing students for the workplace. Whereas 96% of academic leaders such as college presidents feel that their institutions prepare students for success in the workplace, only 11% of business leaders agree with that assessment [30]. Students are similarly unimpressed with their alma maters. According to Gallup's surveys of college graduates, "only 22% strongly agree they had a mentor who encouraged their goals and dreams and only 27% strongly agree they had a professor who cared about them personally during college" [6]. Neither of these polls bodes well for the future of traditional higher education.

Several trends are adversely affecting institutions of higher learning: decreased state funding for higher education, a declining population of teenagers, and the growth of online learning. Skills, expertise and knowledge matter to employers, not college degrees. One example of this is the steady increase in the proportion of employees at Google without any college degree [19]. Based on these trends, one scholar predicts that half of the 4,000 colleges and universities in the United States will be bankrupt within the next few decades [28].

A research points out that currently, more than 800 colleges are at risk and may not survive [45]. The institutions of higher education that survive will be the ones that learn how to eliminate waste and realize ultimate efficiency. Bloat and waste are the enemies of productivity and efficiency. Resources that are wasted on nonsense are not available to improve quality. This paper will demonstrate how colleges and universities can easily save millions by becoming more efficient.

### **Networking and/or merging colleges and universities**

Several researchers have been promoting the networking of universities, i.e., several institutions collaborating and partnering so that costs can be shared. Networked colleges could share administrative costs (e.g., career services, international recruitment, and/or admissions) as well as courses in low-enrollment areas [45][50, pp. 125-134]. This approach stresses collaboration rather than competition among different institutions.

An obvious model: The Five College Consortium of Amherst, Hampshire, UMass, Mount Holyoke, and Smith allows for cross-registration of students, shared curricula, greatly enhanced library resources, shared faculty appointments, and joint purchasing of materials and health insurance. As Carol Christ, president of Smith, notes in her essay about partnerships, "The College Without Walls," the sharing makes each institution small and large at once, greatly expanding elective possibilities without in any way threatening the very different identities of the campuses (Weisbuch, 2014).

Some struggling colleges are trying to survive by merging with other colleges and thereby cutting costs. Merging is obviously a more drastic move than simply networking. In Georgia, for example, two-year and four-year colleges are being merged. Thus, Gainesville State College, a two-year college, merged with North Georgia College and State University, a four-year college to form the new University of North Georgia. This type of merger makes it very easy for students to move from a two-year college to a four-year college. Pennsylvania and Vermont are also looking into mergers as a way to cut costs. One researcher found that the mergers taking place in Georgia have improved the two-year college completion rate by 7.4% [41].

### **Merging academic departments and schools**

Although higher education is changing, most notably with the growth of online education, the academic department has “survived largely unchanged – even untouched – by reform” [17]. But to realize much-needed efficiency in higher education as well as to foster interdisciplinary teaching and scholarship, the academic department structure must be reexamined and reformed. Indeed, to substantially improve institutions of higher education, the academic department model must be improved.

According to an article about having a multitude of academic programs [5], at least 25% of all academic programs offered at a typical college are small, awarding fewer than seven degrees annually, with Physics and Germanic languages small across the board. The paper by [18] asserts that reducing the number of departments via mergers may benefit a college or university in many ways. It can help reduce wasteful administrative bloat, eliminate the silo mentality, encourage interdisciplinary and multidisciplinary programs and research, and improve organizational agility. Moreover, merged departments can provide students with a broader outlook than those whose major departments are too narrow. He also provides procedures for determining which departments to merge. It should be much easier to merge departments within a college than to merge two-year and four-year colleges.

Colleges with approximately the same number of students often have huge differences in the number of their departments. With little accountability for their executive actions, college presidents often create departments for the wrong reasons. Some are created for political reasons, e.g., to satisfy a particular interest or ethnic group even if there is no student demand for this major. The argument used is that we have to provide a “voice” for \_\_\_\_\_. Of course, this is specious reasoning: The purpose of an academic department is not to give an academic presence to any single sociological, political, or ethnic group but to educate and provide skills to students. But even if a case could be made that such groups must be represented in the academic structure, a merged department encompassing numerous such groups should not detract from the academic identity of any subsumed group. Thus, a strong Diversity Studies Department could be more effective than twelve small splintered departments representing 12 different groups. Indeed, if a *raison d’être* of departments is to provide a presence for underrepresented groups, the flood gates are open to an endless array of groups that could clamor for such representation: African-American Studies, Asian Studies, Buddhist Studies, Catholic Studies, Muslim Studies, Native Indian Studies, Children Studies, Disability Studies, Elder Studies, Hindu Studies, Judaic Studies, Latino Studies, LGBT Studies, and Women’s Studies. There are other poor reasons for department creation: sometimes a donor requests that the college create a department. The worst basis for creating a department is when either a president or a dean does so to demonstrate that s/he is innovating, reorganizing or otherwise working hard. Some college presidents brag about

having created five, six, seven, or ten new academic departments and/or schools as though they had developed new products.

The department structure has contributed to administrative bloat. It is difficult for one provost to work with thirty or more chairs (a span of control problem). This encourages the addition of layers of bureaucracy, such as deans and assistant deans. However, once a department is created, it is usually around forever because departments are closed or merged only when they have no students. Colleges are far more likely to add new departments than to merge existing departments. Too many academic departments results in too many schools. John Reynolds, president of Morningside College, made a telling remark which may explain why many institutions are in trouble: “Colleges are very good at adding. They’re not good at subtracting” [34].

New departments can, in theory, bring in more students, but not if they cannibalize each other. It does not take any talent to create a new department, whereas it takes expertise to reduce the number of departments. While it is difficult politically to eliminate departments, it is less difficult to merge them. A key advantage of merging academic departments is that it simplifies the reduction of the number of schools and administrators. Reducing the number of departments also leads to greater efficiency and lower costs by reducing space and staffing requirements for redundant offices

Perhaps the most unfortunate result of creating too many departments is that departments and deans often discourage collaboration with scholars from other disciplines. A paper observed that “Universities are probably better known for turf battles than for communication and collaboration across disciplines [35]. Loyalty is usually to the department or discipline even if it means that the university or even, sometimes, the students, will be shortchanged.” This is all the more senseless in an era when disciplines are converging and silo-busting has become an important management goal. Businesses have come to realize that silos breed tribalism and a refusal to collaborate and share knowledge [49]. A large multiplicity of academic departments with silo mentalities represent unnatural academic divisions that run counter to interdisciplinary scholarly endeavors.

The reality is that collaboration among several authors, especially those from different disciplines, produces better and more impactful scholarly papers than research conducted by single authors [11]. A quote from a research paper states “Almost all significant growth in research in recent decades, the committee [National Research Council] concluded, has occurred at the ‘interdisciplinary borderlands’ between established fields” [32]. The authors in [[15] maintain: “Psychologists have demonstrated the value of diversity – particularly diversity of viewpoints – for enhancing creativity, discovery, and problem solving.” There is much more “boundary crossing and interdisciplinary activity” today than in the past [32]. One example of such fruitful boundary crossing is the hot field of business analytics, which combines computer science, statistics, and marketing.

“When machines come for our jobs, we will need skills in communication, creativity, collaboration, and complex thinking to compete” [1]. The educational system of today, which made sense for people working in farm and factory economies, will not work in the present knowledge economy. The paper affirms that students will need combined majors. Students need to be trained in “humanics” which combines data science, technology, empathy, and the liberal arts.

## Reducing administrative bloat

A college or university that wants to improve efficiency and quality would do well to emulate the new corporate models that emphasize reducing layers of bureaucracy. The state-of-the-art business model prescribes the flattening of the corporate structure to achieve maximum creativity and efficiency. The latest computer technology is being used toward this end. Hence, the goal at many innovative organizations is to decentralize the organizational structure, flatten the organizational hierarchy and reduce layers of bureaucracy as a way to promote open communications, make organizations more agile and effective, and enhance employee involvement.

A flat organizational structure is characterized by short chains of command and a wide span of control, which refers to the number of subordinates controlled by the supervisor. A tall, or hierarchical, organizational structure is marked by long chains of command and narrow spans of control. Each additional layer of bureaucracy slows down decision-making, increases costs, and hurts creativity. In the knowledge economy, no efficient business can afford a complicated organizational hierarchy.

In 2009, *The Economist* surveyed 349 executives from all over the world and found that 90% identified *organizational agility* as a “core differentiator in today’s rapidly changing business environment” [16]. Researchers at McKinsey & Company have studied organizational health and found that firms have to be flexible and move quickly because of the rapidly changing business environment [2]. This research corroborates the contention that too many layers of bureaucracy lead to organizational sluggishness and the inability to change.

In academe, by contrast, the trend over the last several decades has been to increase the number of administrators and support staff. Administrative bloat – the problem of too many administrators – has resulted in an inordinate amount of waste in higher education [21], [27, Report No. 239]. Consultants who have examined several major universities have found that their organizational structure consists of too many layers of management. Too much bureaucracy reduces agility and efficiency in academia as well as in the business arena. A paper [31] asserts: “universities are complex, decentralized institutions. They waste a lot of money on redundant administrative activities and could probably save money in the long run if they made big changes to their structure.”

The federal government is concerned with efficiency, and ostensibly seeks ways of reducing tuition costs but at the same time it is partially responsible for administrative bloat. Between 1993 and 2007, the ratio of number of administrators per 100 students grew by 39%; the funds spent on administration per student (inflation-adjusted) grew by 61%. The ratio of administrators to students went from 1:84 in 1975 to 1:68 in 2005; and the ratio of professional staffers went from 1:50 in 1975 to 1:21 in 2005 [26]. From 1987 to 2011-2012, public universities and private nonprofit colleges collectively added 517,636 administrators and professional employees. From 1976 to 2011, a period of surging government assistance to education, the number of full-time nonfaculty professionals rose by an astounding 369% while the percentage increase in the number of full-time faculty with tenure and on tenure tracks was only 23% [12]. Ginsberg states:

Indeed, for every \$1 spent on instruction, \$1.82 was spent on non-instructional matters including ‘institutional support,’ i.e., the care and feeding of deanlets. If the ratio of deanlets to professors in 2010 had been the same as in 1976, there would now be nearly 400,000 fewer deanlets whose combined salaries

account for one-fourth of all tuition dollars paid by students and their parents in 2010 [26].

It is clear that the high cost of tuition is due to the hiring of more administrators, not more educators [36]. Increasingly, colleges are relying on adjuncts and faculty on non-tenure tracks to do much of their teaching. In explaining administrative bloat, tuition accounts for a relatively small share of a university's revenues, most of which come from government and private gifts [27]. If colleges had to rely more on tuition revenue, they would be forced to reduce administrative bloat. At CUNY, tuition and fees account for as little as 38% of the entire college budget at some schools (City College and Medgar Evers College) to a high of 65% (Baruch College). Interestingly, the best way to reduce administrative bloat is for government to reduce subsidies to higher education and thereby force colleges to be more efficient [27].

A report entitled "Labor Intensive or Labor Expensive: Changing Staffing and Compensation Patterns in Higher Education" recently released by the Delta Cost Project substantiates the problem of administrative bloat in higher education [10]. They found that colleges are using many more administrators, reducing the number of full-time faculty, and increasing the use of adjuncts. As a result, salaries for full-time faculty have remained quite flat [10].

It might be time to evaluate current metrics and develop new ones with the purpose of assessing whether the overhead associated with administrators and support staff is providing value.

Unfortunately, there seems to be little interest in measuring administrative productivity, with the focus solely on determining faculty productivity and learning outcomes. New metrics are being used by schools across the country to measure faculty productivity [4], and the same should be done to measure administrative productivity.

During the last several years, numerous colleges have adopted a school structure, with schools headed by deans, believing that this is more efficient. Many faculty members suspect that the true reason for creating a school structure was to take power away from elected chairs and give the power to appointed deans. At many colleges without a school structure, the chain of command is quite simple: faculty member > chair of department > provost. This chain works quite well when the number of departments is kept reasonably low. At many colleges with a school structure, the chain of command is the following: faculty member > chair of department > assistant dean > dean > associate provost > provost.

Given the high cost of a school structure, research should be conducted to see whether this works better than a simpler structure without schools. Reducing the number of academic departments to, say, 25, may obviate the need for a school structure. At the very least, colleges and universities should be encouraged to minimize the number of schools.

### **Prioritizing criteria to decide which programs to eliminate**

Several colleges are having financial difficulties and are using an approach, known as prioritizing criteria, described by [14], to decide which programs to cut [34]. This approach can also be used to eliminate entire departments. Various methods are used to determine which academic departments are pulling their weight [18]. Given that most colleges have many small departments, it is important in times of financial exigency to measure the contribution of each individual academic department. The goal need not be the elimination of departments but rather to determine which ones should be merged or repositioned. Many dying statistics departments



have come to life by placing new focus on analytics. To reestablish their currency, geology departments have been renamed Earth and Environmental Sciences and begun to offer courses addressing emerging concerns and interests. Existing course contents have also been updated to attract students.

Morningside College, a college having financial difficulties, used prioritizing criteria to determine which programs should be terminated. An academic task force was assigned the task of ranking programs from 1 to 135 using four criteria: student demand (weight = 35%), quality of the program (30%), program's use of resources (20%), and compatibility of the program with the overall mission of the college (15%). The college president then decided which programs among the bottom 50% (i.e., ranked 68 or less) should be cut. Sadly, programs that were cut included physics and philosophy.

Another approach, involving the use of spreadsheets, is being used to improve the productivity of individual faculty members and departments at various colleges and universities. Schools such as the Texas A&M University system are using spreadsheets to evaluate gains and losses from each faculty member. This is calculated by determining the revenues generated by each faculty member (grants, number of students, etc.) and then deducting the expenses (salary of faculty member, costs of labs, etc.). This is also being done for each department [46]. The balance sheet approach has demonstrated that some faculty members at Texas A&M netted their schools as much as \$280,000, while others cost their institutions \$45,000. Some departments generated gains of more than \$5 million for their colleges, while others cost their institutions more than \$1.4 million. Without accountability, there is no pressure to make improvements. Unprofitable departments do not necessarily have to be shut down; merging two small departments can yield great improvements to productivity. The goal is transparency that leads to accountability and increased efficiency.

Responsibility Center Management (RCM) is another method used to ensure that resources are not squandered on departments that are not producing revenues for the institution. With RCM, the college is divided into two types of centers: Revenue-generating centers (schools and departments) and non-revenue generating centers (administrative service centers). The revenue-generating centers have to produce sufficient revenues to cover the "direct cost of their own operations" as well as the allocated costs of the administrative service centers [20].

Many colleges and universities are guilty of rarely examining its program offerings to see which need to be repositioned, modernized, or eliminated; colleges should have procedures for determining which programs need to be fixed. Companies are very quick to prune their product lines and eliminate or reposition sick brands and institutions of higher learning would do well to do the same. It should not take years for programs to be added or eliminated. Kodak was a little slow and moving to digital cameras because of the enormous profit they made from film. As a paper [37] notes: "There are few corporate blunders as staggering as Kodak's missed opportunities in digital photography, a technology that it invented.

It is interesting to note that one metric most academic institutions are concerned with is outcomes assessment or assessment of learning, with 84% of colleges having established learning goals for students [4]. In fact, a typical institution uses five different approaches to assess student success, the most popular of which is student surveys [4]. Whether assessment works or is a waste of time is debatable. An opinion is made that if there were evidence that such assessment provided some real value such as enhancing a college's reputation or providing skills that make it easier for students to find jobs, faculty might be more supportive of it [24]. The paper also states "We should no longer accept on faith or intuition that learning-outcomes

assessment has positive and consequential effects on our institutions — or students” [24]. Many faculty members believe that reviewing course syllabi frequently or surveying students a few years after they graduate will accomplish as much as learning-outcomes assessment at a fraction of the cost. At many institutions, assessment means that more bureaucrats being hired for yet another possibly meaningless task.

There has been publication about BS in academe [47]. Three kinds of BS he underscores are:

BS is universities hijacked by the relentless pursuit of money and prestige, including chasing rankings that they know are deeply flawed, at the expense of genuine educational excellence (to be distinguished from the vacuous "excellence" peddled by recruitment and "advancement" offices in every run-of-the-mill university).

BS is undergraduate "core" curricula that are actually not core course systems but loose sets of distribution requirements, representing uneasy truces between turf-protecting divisions and departments intent on keeping their classes full, which students typically then come to view as impositions to "get out of the way."

BS is administrators' delusion that what is important in higher education can be evaluated by quantitative "metrics," the use of which will (supposedly) enable universities to be run more like corporations, thus requiring faculty and staff to spend more time and energy providing data for metrics, which they, too, know are BS [47].

It is not surprising there are so many flaws in the assessment process – e.g., none of the instruments used have been tested for reliability and validity – that it is as likely to cause more harm than good. It is not clear that measuring “learning outcomes” has resulted in improving the quality of education [54], [38, B11-B13], [23, A25], [24, A50-A51]. A paper asserts that it is an open secret among assessors that “assessment has not caused (and probably will not cause) positive changes in student learning” [23]. In any case, it has resulted in the hiring of more administrators.

## CONCLUSION

The first change that has to be made for the purpose of cutting costs and improving efficiency in higher education is to hire college presidents that act like true leaders and care for their organizations more than for themselves. College presidents, as well as provosts, are often more concerned with enhancing their CVs than doing what is best for the college they are paid to lead. They are primarily motivated about what will make them look good for their next job. This is why they love creating more structure. It allows one to say that one created new schools and/or added new departments, which looks good on a CV and might lead to finding a better job in the future. Of course, no one asks whether the additional structure made a school more efficient. The average tenure of college presidents is only seven years, and their average age is 61 [48]. The average tenure of a chief academic officer/provost is only 4.7 years [39]. It should therefore

not be surprising that the loyalty of the college leadership will not be to the institution, but to themselves. Padding the CV often matters more than making meaningful improvements. The key metrics that can be used to measure the true performance of college presidents are discussed in [22].

Colleges are broken and need to transform themselves; it is not only about inefficiency and bloat. A recent Gallup Poll found the following:

Colleges and universities are supposed to be learning organizations. But, apparently, they aren't doing enough learning themselves -- at least not among their staff and faculty. According to Gallup surveys, college and university employees rank right around the bottom-quartile on "learn and grow" measures compared with other employees in the U.S. This is a tragic irony for the very workplaces whose primary mission is, well, learning and development. Specifically, only four out of 10 higher education staff and faculty strongly agree that in the past year they've had opportunities at work to learn and grow. And even fewer strongly agree that someone at work has discussed their progress in the last six months or that someone at work encourages their development [6].

Institutions of higher learning that refuse to make any changes or focus on nonsense metrics to demonstrate that learning is taking place will wake up one morning and find that they are no longer viable and have gone the way of numerous colleges that have disappeared. More and more politicians are speaking out against college degrees that they feel are of little value in the employment market. An author believes that Ronald Reagan, then Governor of California, may have triggered a major shift in the public's view of higher education from an intellectual to a vocational enterprise [3]. On February 28, 1967, President Reagan stated that "there are certain intellectual luxuries that perhaps we could do without" and argued that taxpayers should not be "subsidizing intellectual curiosity" [3]. Since then, many politicians have said the same thing about higher education. Some academics as well have been positing that college is not for everyone. According to conclusion of a paper, "If everyone had a college degree, the result would not be great jobs for all, but runaway credential inflation" [9]. Trying to spread success with education spreads education but not success. Credential inflation refers to the fact that as more and more people earn college degrees, the value of the degree declines. This is what happened to high school diplomas which meant much more when only 10% of the population had them.

For better or worse, colleges and universities have to be aware that skills have become the new mantra and schools will have to learn to be efficient in teaching useful workplace (and life) skills to students. The first step is to reduce bloat and waste and make colleges and universities more efficient. The resources that are freed up should then be used to improve the quality of education.

## REFERENCES

- [1] Aoun, J. E. (2017, November 24). The experiential component. *Chronicle of Higher Education*, A5.

- 
- [2] Bazigos, M., De Smet, A. & Gagnon, C. (2015, December). Why agility pays. *McKinsey & Company*. Retrieved from [http://www.mckinsey.com/insights/organization/why\\_agility\\_pays](http://www.mckinsey.com/insights/organization/why_agility_pays)
- [3] Berrett, D. (2015, January 30). The day the purpose of college changed. *Chronicle of Higher Education*, A18- A21.
- [4] Berrett, D. (2014, January 31). Colleges measure learning in more ways, but they seldom share results. *Chronicle of Higher Education*, A12.
- [5] Brainard, J. (2010, April 2). Having a multitude of small academic programs is common – but risky. *Chronicle of Higher Education*. A12.
- [6] Busted, B. (2018, January 9). Colleges: Learning organizations that aren't learning. *GALLUP News*. Retrieved from [http://news.gallup.com/opinion/gallup/225059/colleges-learning-organizations-aren-learning.aspx?utm\\_source=alert&utm\\_medium=email&utm\\_content=morelink&utm\\_campaign=syndication](http://news.gallup.com/opinion/gallup/225059/colleges-learning-organizations-aren-learning.aspx?utm_source=alert&utm_medium=email&utm_content=morelink&utm_campaign=syndication)
- [7] Byrnes, H. (2019). U.S. leads among countries that spend the most on public health care *USA Today*. Retrieved from <https://www.usatoday.com/story/money/2019/04/11/countries-that-spend-the-most-on-public-health/39307147/>
- [8] Cain, A. & Biron, B. (2019). These 15 retailers have filed for bankruptcy or liquidation in 2019. *Business Insider*. Retrieved from <https://www.businessinsider.com/bankrupt-companies-retail-list-2019-3>
- [9] Caplan, B. (2018). The world might be better off without college for everyone. *Atlantic*, January/February. Retrieved from <https://www.theatlantic.com/magazine/archive/2018/01/whats-college-good-for/546590/>
- [10] Carlson, S. (2014, February 5). Administrator hiring drove 28% boom in higher-ed work force, report says. *Chronicle of Higher Education*. Retrieved from [http://chronicle.com/article/Administrator-Hiring-Drove-28-144519/?cid=at&utm\\_source=at&utm\\_medium=en](http://chronicle.com/article/Administrator-Hiring-Drove-28-144519/?cid=at&utm_source=at&utm_medium=en)
- [11] Council of State Governments (2015 April). America's knowledge economy: A state-by-state review. *Elsevier Report*. Retrieved from [http://www.csg.org/programs/knowledgeeconomy/Elsevier\\_Report\\_2015.pdf](http://www.csg.org/programs/knowledgeeconomy/Elsevier_Report_2015.pdf)
- [12] Data Point (2014, April 18). Behind the numbers in the news. *Chronicle of Higher Education*, A23.
- [13] Delventhal, S. (2018, January 3). Amazon made up 4% of all US retail in 2017: study. *Investopedia*. Retrieved from <https://www.investopedia.com/news/amazon-made-4-all-us-retail-2017-study/>
- [14] Dickeson, R. C. & Ikenberry, S. O. (2010). *Prioritizing academic programs and services: Reallocating resources to achieve strategic balance*. San Francisco: Jossey-Bass.
- [15] Duarte, J. L., Crawford, J. T., Stern, C., Haidt, J., Jussim, L., & Tetlock, P. E. (2015). Political diversity will improve social psychological science. *Behavioral and Brain Sciences*, 38, 1-13. DOI:<http://dx.doi.org/10.1017/S0140525X14000430>
- [16] Economist Intelligent Unit (2009 March). Organisational agility: How business can survive and thrive in turbulent times. *Economist*. Retrieved from <http://www.emc.com/collateral/leadership/organisational-agility-230309.pdf>
-

- [17] Edwards, J. (1999). The academic department: How does it fit into the university reform agenda? *Change: The Magazine of Higher Learning*, 31(5), 17-27.
- [18] Friedman, H. H. (2018, January 2). How the creation of too many academic departments stifles creativity, encourages a silo mentality, and increases administrative bloat. Available at SSRN: <https://ssrn.com/abstract=3095370>
- [19] Friedman, T. L. (2014, April 20). How to get a job at Google, part 2. *New York Times*, SR1, SR11.
- [20] Friedman, H. H. & Friedman, L. W. (2018). Does growing the number of academic departments improve the quality of higher education? *Psychosociological Issues in Human Resource Management*, 6(1), April, 96-114.
- [21] Friedman, H. H. and Kass-Shraibman, F. (2017, May 10). How to Pad Your CV. *Inside Higher Education*. Available at <https://www.insidehighered.com/advice/2017/05/10/tongue-cheek-primer-help-dishonest-administrators-advance-essay>
- [22] Friedman, H. H. & Kass, F. (2016, November 24). Evaluating the performance of college presidents in the age of disruption and corruption. Available at SSRN: <https://ssrn.com/abstract=2875367>
- [23] Gilbert, E. (2018, February 2). An insider's take on assessment: It may be worse than you thought. *Chronicle of Higher Education*, A25.
- [24] Gilbert, E. (2015, September 4). Does assessment make colleges better? *Chronicle of Higher Education*, A50-A51.
- [25] Ginsberg, B. (2011). Administrators ate my tuition. *Washington Monthly*, September/October. Retrieved from [http://www.washingtonmonthly.com/magazine/septembroctober\\_2011/features/administrators\\_ate\\_my\\_tuition031641.php?page=all](http://www.washingtonmonthly.com/magazine/septembroctober_2011/features/administrators_ate_my_tuition031641.php?page=all)
- [26] Ginsberg, B. (2014). Power shift: How the growth of administrators is wrecking our campuses. *AFT on Campus*, Summer, 5-6.
- [27] Greene, J. P., Kisida, B., and Mills, J. (2010). Administrative bloat at American universities: The real reason for high costs in higher education. *Goldwater Institute*, Policy Report No. 239, Retrieved from <http://www.goldwaterinstitute.org/article/administrative-bloat-american-universities-real-reason-high-costs-higher-education>
- [28] Hess, A. (2017, November 15). Harvard Business School professor: Half of American colleges will be bankrupt in 10 to 15 years. *CNBC*. Retrieved from <https://www.cnn.com/2017/11/15/hbs-professor-half-of-us-colleges-will-be-bankrupt-in-10-to-15-years.html>
- [29] Jaschik, S. (2018, July 27). Survey: Most Americans think higher education is headed in wrong direction. *Inside Higher Ed*. Retrieved from <https://www.insidehighered.com/news/2018/07/27/survey-most-americans-think-higher-ed-headed-wrong-direction>
- [30] Keierleber, M. (2014, February 25). Business and academic leaders disagree on quality of college grads, surveys find. *Chronicle of Higher Education*. Retrieved from <http://m.chronicle.com/article/BusinessAcademic-Leaders/144977>
- [31] Kiley, S. (2011, September 16). Where universities can be cut. *Inside Higher Education*. Retrieved from

- [https://www.insidehighered.com/news/2011/09/16/unc\\_berkeley\\_cornell\\_experience\\_show\\_where\\_administrative\\_cuts\\_can\\_be\\_made](https://www.insidehighered.com/news/2011/09/16/unc_berkeley_cornell_experience_show_where_administrative_cuts_can_be_made)
- [32] Klein, J. T. (1996). *Crossing boundaries: knowledge, disciplinarity, and interdisciplinarity*. Charlottesville, VA: University Press of Virginia.
- [33] Lohr, S. & Tejada, C. (2018, February 1). After era that made it a verb, Xerox, in a sale, is past tense. *New York Times*, A1, A11.
- [34] Mangan, K. (2017, November 17). A college weighs its priorities before making cuts. *Chronicle of Higher Education*, A10.
- [35] Manlow, V., Friedman, L. W. & Friedman, H. H. (2010). Inventing the Future: Using the new media to transform a university from a teaching organization to a learning organization. *Journal of Interactive Learning Research*, 21, 47-64.
- [36] Marcus, J. (2014, February 6). New analysis shows problematic boom in higher ed administrators. *New England Center for Investigative Reporting*. Retrieved from <http://necir.org/2014/02/06/new-analysis-shows-problematic-boom-in-higher-ed-administrators/>
- [37] Mui, C. (2012, January 18). How Kodak failed. *Forbes*. Retrieved from <https://www.forbes.com/sites/chunkamui/2012/01/18/how-kodak-failed/#3fa9ed3b6f27>
- [38] Muller, J. Z. (2018, January 26). The tyranny of metrics. *Chronicle of Higher Education*, B11-B13.
- [39] Pierce, S. R. (2011, January 26). Producing academic leaders. *Inside Higher Education*. Retrieved from [https://www.insidehighered.com/advice/2011/01/26/susan\\_pierce\\_on\\_how\\_colleges\\_can\\_attract\\_more\\_academics\\_to\\_senior\\_administrative\\_positions](https://www.insidehighered.com/advice/2011/01/26/susan_pierce_on_how_colleges_can_attract_more_academics_to_senior_administrative_positions)
- [40] Porcarelli, J. (2016, October 13). Harnessing disruption. *NeueVu*. Retrieved from <http://neuevu.com/harnessing-disruption/>
- [41] Quinto, S. (2017, March 29). Merging colleges to cut costs and still boost graduation rates. *Pew Charitable Trusts*. Retrieved from <http://www.pewtrusts.org/en/research-and-analysis/blogs/stateline/2017/03/29/merging-colleges-to-cut-costs-and-still-boost-graduation-rates>
- [42] Quote Investigator (2017). Thirty years from now the big university campuses will be relics. Universities won't survive. Retrieved from <https://quoteinvestigator.com/2017/09/17/university/>
- [43] Raphan, M. & Friedman, H. H. (2014). Adaptivity, Creativity, and Diversification in the Age of Convergence. *Business Quest*. Available at: <http://www.westga.edu/~bquest/2014/convergence2014.pdf>
- [44] Schwab, K. (2016, January 14). The fourth industrial revolution: What it means, how to respond. *WEForum.org*. Retrieved from <https://www.weforum.org/agenda/2016/01/the-fourth-industrial-revolution-what-it-means-and-how-to-respond/>
- [45] Selingo, J. J. (2017, November 17). Networked U.'s: This is what will save higher ed. *Chronicle of Higher Education*, A48.
- [46] Simon, S. & Banchemo, S. (2010, October 22). Putting a price on professors. *Wall Street Journal*. Retrieved from <http://online.wsj.com/article/SB10001424052748703735804575536322093520994.html>

- [47] Smith, C. S. (2018, February 9). Higher education is drowning in BS. *Chronicle of Higher Education*, B6-B7.
- [48] Snyder, S. (2013, July 12). Shorter tenure, higher turnover among college presidents. *Philly.com*. Retrieved from [http://articles.philly.com/2013-07-12/news/40516478\\_1\\_carl-tobey-oxholm-college-president-haverford-college](http://articles.philly.com/2013-07-12/news/40516478_1_carl-tobey-oxholm-college-president-haverford-college)
- [49] Tett, G. (2015). *The silo effect: The peril of expertise and the promise of breaking down barriers*. New York: Simon & Schuster.
- [50] Tobin, E. M. (2014). The future of liberal arts colleges begins with collaboration. In R.Chopp, S. Frost and D. H. Weiss (Eds.), *Remaking College: Innovations and the liberal arts*, pp. 125-134. Baltimore, MD: Johns Hopkins University Press.
- [51] Tyko, K. (2019, August 9). More store closings coming: An estimated 12,000 shops could close by the end of 2019. USA Today. Retrieved from <https://www.usatoday.com/story/money/2019/07/03/2019-store-closings-list-these-retailers-shuttering-locations/1597997001/>
- [52] Wee, S. & Mozur, P. (2018, February 1). Building the hospital of the future. *New York Times*, B1, B7.
- [53] Weisbuch, R. (2014, October 29). Staying small and getting large. *Chronicle of Higher Education*. Retrieved from <https://www.chronicle.com/article/Staying-SmallGetting/149667>
- [54] Worthen, M. (2018, February 25). No way to measure students. *New York Times*, SR1, SR6.

## INFO16X DIGITAL LITERACY PROGRAM

Wilma Andrews, [wandrews@vcu.edu](mailto:wandrews@vcu.edu), Robert Andrews, [randrews@vcu.edu](mailto:randrews@vcu.edu)  
Sindhu Venkatesh, [venkateshs2@vcu.edu](mailto:venkateshs2@vcu.edu), Ashish Sunita, [sunitaai@vcu.edu](mailto:sunitaai@vcu.edu)  
Virginia Commonwealth University, PO Box 84000, Richmond, VA 23284

### ABSTRACT

Virginia Commonwealth University (VCU) School of Business has a large program of online/self-passed/pass-fail/1 credit courses in Digital Literacy. School administrators observed that these classes traditional have a pass rate in the 70% range. They sought to determine the reason for the low pass rate. They concluded there were two major issue: procrastination on the student's part and students not completing the training and/or wait until the very end of the semester to schedule their exams. New policies including required Sequential Modules and early first exam attempt deadlines were initiated for Fall 2019. This paper will compare previous semester results vs. current ones to see if new policies were effective in improving the pass level.

### DIGITAL LITERACY PROGRAM AT VCU

#### History

The INFO16X program started in the 1990's with a series of one-credit hour classes computer courses taught face-to-face. These 7-9 courses were taught in three different 5-week sessions during each fall and spring semester. The courses used a traditional grading scale with numerous non-tenure track and adjunct instructors doing the instruction. With the courses being offered during the three sessions during the fall and spring semesters, students could add a class during the semester. This feature was particularly helpful for a student who did not initially register for a required number of hours to be eligible for financial aid, athletic competition or scholarship. Students with such a requirement could also withdraw from a class and replace it with one or more of these classes to remain full-time or to pick up credits for graduation.

In Spring 2002, the School of Business was facing major budget cuts and decided to move the courses to an online model to reduce instructional costs. The department curriculum committee decided that the courses should be graded pass-



fail rather than awarding a letter grade and the minimum for a pass should be 80%. One instructor was hired to setup and over-see the program. From 400 initial registrations in Fall 2002, the program has grown to 2100-2500 registrations per semester in the current six courses. The online/self-paced/pass-fail/1 credit model was started with seven elective courses.

The current six course program includes computer concepts, comprehensive word processing (Word), two levels of spreadsheets (Excel), database (Access) and presentations (PowerPoint). Since Fall 2014, four of these courses are required for Business majors. The courses are open to all VCU students but 70% are Business majors. Recent registrations in the 6 courses range from 2100-2500 per semester. MyLab IT, a Pearson online product, is used to provide online training, eTexts and comprehensive exams. The product also includes the capability to setup sequential modules which require completion of previous modules in order to advance to the next one.

P/F grades are based on student performance on a final comprehensive exam with an 80% pass level. Final exams are proctored in an on-campus classroom. Traditionally, students had two attempts to pass the one comprehensive exam per course if they took a first attempt by a specific date, but they could also go for one attempt as late as finals week.

### **Pass Level Concerns**

Retention is a hot issue at the University level and these courses often show-up on a D/W/F list generated by the administration. Even though the pass level at 80% is higher than the 70% for other courses on the D/F/W list, two years ago conversations were started to see if changes could be made to improve pass level so that the D/W/F percentages would not be so high. Of special concern were the Business majors Excel scores in the two spreadsheet courses. The School's curriculum committee had a sub-committee look at various options. The suggestion to consider changing to more traditional courses for Excel was not supported by the administration due to a very significant increase for instruction cost and space. So other options inside the current model were considered.

### **Options for Program Changes**

A new policy requires students to take a first attempt by a specified date, and if they don't, they receive an automatic fail grade for the class. Students who take a

first attempt prior to the deadline without passing have a second attempt to pass a second exam.

One option put forward by the School administration was to automatically withdraw a student that had not completed a specified action in the course by the withdrawal date. With the current university policy that allows students to late add these courses thru the withdrawal date, an automatic withdrawal option would not give a student late adding adequate time to complete any specified action. Also taking a first attempt for the exam as the requirement to trigger an automatic withdrawal date would not work since the deadline for taking a first attempt is after the withdrawal date.

A second option was to require the completion of the course's MyLab IT sequential module (SM) prior to being eligible to take a first exam attempt in the hopes that completing the sequential module would assure that students would be better prepared for the exam. The School administrators decided that this should be one policy change for each INFO16X course. This change requires a significant amount of work for the instructor of the INFO16X courses due to having to manually affirm that the students signing up for an exam had completed the sequential model for the course.

The other concern was that students were waiting until exam week to schedule their attempts which took away exam preparation time from their other courses. A third option with a required first attempt thru week 10 was decided upon. If students took a first attempt by that date and did not pass, then they qualified for a retake option thru the end of the semester. If a student did not take a first attempt by that date, they would receive an automatic F.

The School of Business also had made the decision to eliminate the large computer lab in order to create an additional classroom. This lab had been used by the INFO16X program to offer large testing sessions. The only remaining lab option was of a 32-computer lab that was only available after 4:00 PM for INFO16X testing. Since the large lab space would not be available Fall 2019, another new policy was considered that would require students to take the exam using their own computers in sessions that were not scheduled in the smaller lab. There was concern about using personal computers but that was the only option in order to test 2100+ registrations. Rooms with electrical outlets for power cords were needed for additional testing space and those spaces were scheduled. However,

some students would still be able to take their exam in the small lab if they did not have or did not want to use their own computers.

To assist with the new requirements, two graduate assistants working 10 hours a week each were hired. Their responsibilities were to help monitor sequential module completion, to send email reminders to students who had not completed their modules, and to assist with proctoring during exam sessions. The Graduate Assistants were helpful in sending out email reminders 48 hours ahead of scheduled exams to remind those who had not completed their SM's that they couldn't take their exam if the SM was not completed on time. However, 24 hours checks also had to be made by the faculty and entered into the session database. Hiring and training the graduate assistants took many hours of the faculty's time in the fall but they were certainly helpful.

The exam signup website created many years ago was used for scheduling exam sessions. This website enables students to signup/cancel exam sessions online. And provides a printout of those registered for each session. A field also indicates whether they have completed their Sequential Module. At each exam sessions, students signed-in with photo ID's. The database behind the website is generated from Banner downloads updated weekly thru the withdrawal date.

## **FINDINGS**

Sequential Modules were one of the major changes initiated. Each course had one. Students could use the Learning Aids to complete the SM's. Average and max time in each of these by course are shown below. Additional time spent in the Review Chapter modules was not evaluated so these times certainly do not show total time spent in courses.

### **Sequential Modules**

<b>Course</b>	<b>Average Time</b>	<b>Maximum Time Spent</b>
160 Computer Concepts	1:27	8:20
161 Word Processing	7:00	23:00
162 Spreadsheets 1	6:00	12:00
165 Spreadsheets 2	6:00	12:00
166 Database	7:00	22:00
168 Presentations	8:00	17:00

Computer Concepts involved a series of self-tests after eText reading. Times were for self-tests only.

Office applications had hands-on training modules. Number of chapters varied. Students could use Learning Aids (Practice, Video, Text) to complete the SM in the Office courses.

After the completion of the SM, students were encouraged to continue their learning by using the Review Chapter Modules and to do the modules until they could complete them without using the Learning Aids. Those who passed did that, many completed the review modules multiple times. End of course student comments confirmed the importance of working thru the Review Chapter Modules in order to be successful at passing the exam.

### **Laptops**

Another major change was the use of personal laptops instead of all lab computers. The personal laptops worked well with a few exceptions. Students were sent reminder emails about bringing laptops to specific sessions (though their email confirmation also said to bring laptops). Prior to the session students were encouraged to check their wi-fi connections ahead of time, check battery life or bring cords, know how to connect to their phones wi-fi if needed.

Checking laptops out at the Library was also an option used by some students for the sessions that required laptops. Sessions were still offered in the lab with computers for those who didn't want to use their laptops or didn't have one. And there was a definite request for the use of lab computers instead of using their own laptops for various reasons – no laptop, older/slow laptops, no reliable laptop wi-fi connections.

### **Required First Attempts**

Required first attempts at 10 weeks had issues especially with students who were used to the old model and didn't read their course documents or pay attention to email reminders. 200 missed that deadline but that was anticipated when the policy was decided upon.

Over 80 exam sessions were offered during the semester, 55 of which were prior to the first attempt deadline. As in previous semesters, the highest attended sessions were in the week of the first attempt deadline and then again, at the end of the semester for those taking qualified retakes.

Extra credit points were offered early in the semester as an incentive to schedule early. Better prepared students didn't need extra credit points but the incentive still encouraged them to test early.

## Results by Course

Traditionally Word has had the lowest overall average of all the courses and was in the Fall. This could be because students don't spend the time preparing because they think they know Word having used it previously. Survey results generally include comments like "I thought I knew Word but I was exposed to features I didn't know Word had." Another one said, "Before all I knew how to do in Word was type, save and print."

Fall 19

Course	P	F	W	Totals	%P
INFO160	301	83	19	403	75%
INFO161	366	154	32	552	66%
INFO162	461	169	48	678	68%
INFO165	269	94	18	381	71%
INFO166	105	11	6	122	86%
INFO168	35	7	1	43	81%
Grand Total	1537	518	124	2179	71%

Second lowest is Excel. Excel has features that many of our students have not used before. But for Business majors those skills are important. And efforts have been made to include more Excel in other courses after this one which reinforces what the students have been exposed to in the course.

## Samples of Student Survey Input

Student input varies based upon their previous knowledge of the 6 courses. Some arrive on campus very knowledgeable. For those students who think they know the content, there are 3 Knowledge Equivalency Tests (KET) that students can pay for and take for Computer Concepts, Word and Excel 1. These exams do not give them academic credits but does give prerequisite requirements for other Business courses. However, the pass level in the KET's has not been high. Students may not know as much as they think they know.

Below is a sample of replies students made to the following questions. (A Blackboard survey was also offered to students with different questions) :

1. What specific topics did you learn from taking the course? And don't just look for a list of topics from the chapter headings. I want your input on what you really learned.
2. What advice would you give to another student taking the course to help them be successful?
3. How will what you learned benefit you in your future academics and career?

1. These courses were originally just a requirement for me that I didn't think I would have to assert a lot of effort/ care about. But once I took the first exam and

realized I had to know what I was doing to pass the class, it became less of a chore and I absorbed the information eventually, and once I knew what I was doing, it was almost fun to complete. So in addition to learning the vocabulary from 160, the ways to use Word through 161, and Excel spreadsheets from 162 and 165, I learned how to study properly by continuously working through the modules, and making a quizlet for 160.

2. Being a transfer student, I had no idea what these courses entailed so I really wish I had gotten started at the beginning of the semester. The modules can be painful when you are trying to cram to get them done for the test. And not only that, you would never be able to pass without going over the modules and vocabulary continuously, until you don't need to watch the videos or use the practice helpers anymore. Also, I would advise to sign up for the exams in advance, and spread them out so you do not have to cram for each test.

3. My major is business management, so I will have to write many papers and create lots of spreadsheets not only in the rest of my time as a student, but also in my future career, whatever that may be. Being able to write a formula for statistics on a spreadsheet without having to look it up or ask for help will be very helpful in my future.

#### Other Quotes

With this class, I also learned how to study, which is something I would not have expected coming from a mandatory “computer class.” And I am very grateful I learned that lesson quickly.

Thanks again,

From INFO 165 I learned a lot of various things about excel. I wasn't aware that you can sort multiple fields, subtotal the date and then add a second subtotal. I also learned how to create a Recommended PivotTable, how to add rows/columns to a PivotTable and change the value field settings. I also learned what the function of a slicer is and how to insert and customize it.

I learned how to construct formulas, charts of many different kinds, and pivot tables in an effective way. Not only did I learned to make these charts, but I also gained knowledge on how to insert the proper data into said charts. What also came with inserting the data into the charts was how it could be more easily inserted by using several functions such as the auto sum function. Overall, this knowledge makes it easier for me to represent my data and get my points across to others while also validating it.

## Blackboard Survey Results

Each semester we give students opportunities for input with a survey posted at Blackboard. The following from Fall 2019 is consistent with previous semesters results. Students felt their knowledge had increased and they would recommend the course to other students.

Courses	Knowledge/Skill Level			Would Recommend Course to other Students
	Increased Greatly	Increased Some	Remained the Same	
160 Computer Concepts	31%	57%	12%	78%
161 Word Processing	55%	41%	4%	80%
162 Spreadsheets 1	55%	43%	2%	80%
165 Spreadsheets 2	53%	39%	8%	80%
166 Database	77%	23%		82%
168 Presentations	25%	75%		100%

## CONCLUSIONS

Results of the first semester with the new requirements did not give the hoped for results. Historically, 10% of registered students do nothing and this was true again this fall. (Doing nothing meant that those students did not even setup a MyLab IT account.) Another 10% setup their accounts but did not get their first exam attempt in by the deadline. Both of these groups received automatic F's.

Procrastination continued to be a big issue. The online/self-paced format seems to contribute to procrastination. Even with numerous email reminders including a listing of average times needed to complete Sequential Modules, too many students hurried thru the SM's without really learning the content with poor exam results. Evaluations continued to say the online/self-paced nature of the courses was hard for many because they were used to weekly face-to-face classes with more deadlines and homework.

Of those that took exams, the difference in pass/fail levels between the last 4 semesters and last fall was not significant with all courses included. (See the following chart). However, previous semesters had a required minimum of 40 points to qualify for a retake which raised the first attempt score averages. Fall 19 did not. So lower scores with completed SM did qualify for retakes and students could use the Learning Aids to complete the SM without really trying to learn the tasks. Maybe the 40 minimum score needs to be reinstated.

Also, Spring scores have traditionally been higher than Fall scores. Probably because students were more aware of the process. Spring 20 scores may show the same results.

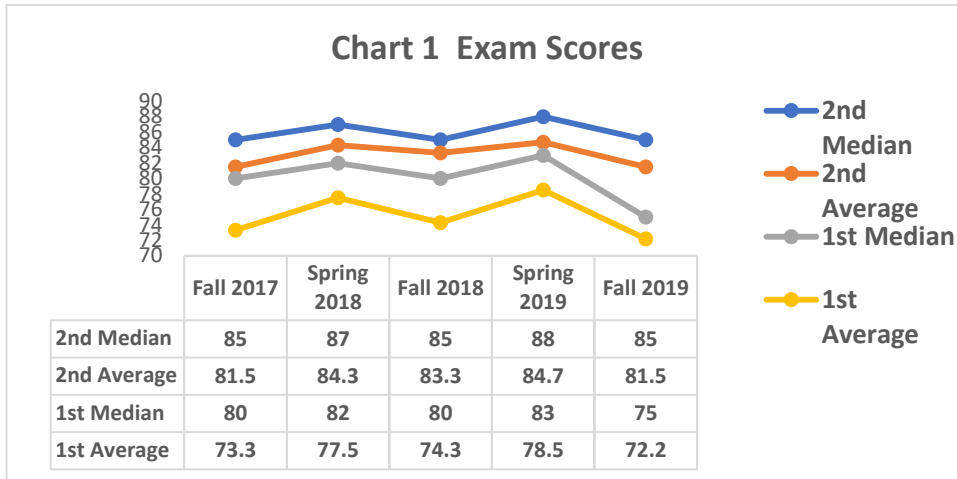

Student feedback confirms they think there is value in the courses. The challenge is getting more students to put forth the effort to learn the content not just do the minimum to pass. The Office skills are certainly used in other courses. Those who do minimum effort or ignore the courses, are not thinking ahead to the consequences on their GPA's and the academic records future employers may review.

Additional evaluation will be carried out on some of the specific topics in a data mining course this spring. And after Spring semester hopefully there will be an improvement once "the word gets out" about the tougher policies. Maybe students will be more aware of the requirements and consequences of not reading course documents and emails.



**INNOVATIVE EDUCATION AT STUDENTS' FINGERTIPS:  
USING LMS PERFORMANCE FEEDBACK MECHANISMS TO RETURN CONTROL  
OF LEARNING PROGRESS TO LEARNERS**

Ruth C. King

Department of Accounting, Finance, Healthcare and Information Systems  
Broadwell College of Business and Economics, Fayetteville State University  
Fayetteville, NC 28303, 217-891-4354, [rking6@uncfsu.edu](mailto:rking6@uncfsu.edu)

**ABSTRACT**

Many introductory or online courses face high "DFW" issues. High failure rates can be attributed to many factors, but the consequences are significant not only to students and instructors but the society and future workforce. This study documents a series of experiments by applying different performance feedback mechanisms to provide students with real time performance signals and to keep them informed about their learning outcomes. The background of this study is a self-guided software learning course (Microsoft Office Suite) with five individual modules: Basic Computing, Word, Excel, Access and Power Point. Instructors serve as coaches to guide the progress of modules, remind students of the deadline and solve technical and learning problems.

One of the major concerns in this course was the low performance of student's learning outcome. Since this course involves 22 assignments (15 training, 3 projects, and 4 midterms) with various weights assigned to each assignment, students frequently asked instructors to calculate/update their current performance. Feedback research has shown that providing prompt and meaningful feedback to learners about their learning status is beneficial to motivate them to continue their learning journey and achieve their final goals. Apparently, student's knowledge of their performance at any moment can be significant information for them to identify their learning gap, current performance and strategies to steer their future effort in time to reach their expected outcome.

Three different controls were implemented to three different groups of students (28 students in each group) under the same instructor. The first experiment was to teach students to apply the grading formula posted on the syllabus so students can obtain their status any time on their own. The second experiment was to apply the assignment grouping mechanism and assignment weighting scale embedded in the Learning Management Systems (LMS) so that the overall performance can be published on the LMS synchronously with the assignment Software. The third experiment was to creatively modify the performance feedback mechanism provided by LMS since the mathematical logic behind the grading program is not reflecting the actual scores in relationship with the formula

The results show that DFW rates under the first and second experiment experienced minor decrease of DFW rates from the baseline but students under the third experiment experienced more significant decrease. The findings suggest that true performance feedback that allows students to access at any time returns control to students. This technology-enabled feedback mechanism helps direct students' continual effort and enable them to devise productive strategies to reach their learning goals. Statistics will be presented at SEDSI.

## **Learning Engaged Scholarship through a MIS STEM Camp**

April H. Reed, College of Business – MIS Department, East Carolina University, 1000 E. 5<sup>th</sup> St., Greenville, NC 27858, 252-328-6631, reeda@ecu.edu  
Lyubov G. Sluder, College of Business, East Carolina University, 1000 E. 5<sup>th</sup> St., Greenville, NC 27858, [Sluderl07@ecualumni.ecu.edu](mailto:Sluderl07@ecualumni.ecu.edu)

### **ABSTRACT**

Many students in public education are limited in their access to Science, Technology, Engineering and Math (STEM) education. STEM camps are a common method used to introduce students to these important disciplines. This research study began as an Engaged Scholarship project; a Management Information Systems (MIS) STEM camp to introduce participants to technology and targeting middle and high school girls. Surveys were used to measure the impact of the camp. Statistical analysis of results did not show a significant increase in attitudes towards technology; however, a positive change did occur in their confidence in the ability to perform technical work.

### **INTRODUCTION**

Science Technology Engineering and Math (STEM) camps have been commonly used to introduce students to these important disciplines before they reach college. Without this exposure, many students will have little or no knowledge of these fields and hence no access to them as lucrative and fascinating careers. Our goal for developing this Management Information Systems (MIS) STEM Camp was to advance technology STEM education in Eastern North Carolina (ENC) counties. We also wanted to address the critical need for females to enter career paths in under-represented areas of STEM fields, specifically technology-related fields such as MIS. ENC has a large percentage of rural counties, many of which are in Tier One and Tier Two as reported by the North Carolina Department of Commerce [11]. A statute provides the guidelines for assigning the tiers as follows: Tier One (most distressed), Tier Two or Tier Three (least distressed). The following four factors are used to assign the rankings; 1) average unemployment rate, 2) median household income, 3) percentage growth in population and 4) adjusted property tax base per capita. Participants at our camp came from predominately Tier One counties and one Tier Two county. Additional information on the counties is provided in the Demographics section of this paper.

This project was originally developed through the Engaged Outreach Scholarship Academy (EOSA) at a large public university in Eastern North Carolina. The EOSA program introduces professors and students to the importance of combining an outreach program with research while partnering with a community organization. The authors participated in EOSA and were mentored on how to develop a program through a true partnership in the community while producing research data.

Interest in STEM programs for underrepresented minorities and students in rural areas is evidenced by legislation supporting these types of activities such as H. R. 5116 (America Creating Opportunities to Meaningfully Promote Excellence in Technology, Education, and Science Reauthorization Act of 2010). The ACT® report on the state of STEM Education

produced results which reinforce the need for improvements in STEM education. This report, *STEM Education in the U.S.: Where We Are and What We Can Do: 2017* states “It’s difficult to admit, but the United States is a STEM-deficient nation” [3, p.3]. The report contains several key findings, i.e. Finding #1 shows stagnation in interest and achievement in STEM fields in the U.S, in the past five years. The percentages are as follows [3]: 2012 - 48%, 2013 - 48%, 2014 - 49%, 2015 - 49%, 2016 - 48%, 2017 - 48%.

Accenture and Girls Who Code’s recent study on females in the STEM fields [1] triggered our focus on females from under represented areas for our camp; it stated that, “the number of women in the US computing workforce will drop from 24% to 22% by 2025 if tech leaders and others don’t intervene” [5, p.1]. Since the number of females in computing fields is already low, this is a serious problem. The study suggested that a possible solution to this problem is “working with today’s junior high school girls and from sustaining their interest in computing as they progress through their education” [1, p.3]. The report further stresses the urgency of the issues stating, “that means we need to act urgently if we are to reverse today’s alarming trends” [1, p.3]. Additional evidence of gender differences in STEM comes from Finding #6 in the ACT® 2017 report, which noted that while the proportion of students expressing an interest in STEM was almost equal across gender with ACT-tested female graduates at 47% and male graduates at 50%, the ability of students to pursue these careers, i.e. attainment, is the problem. The finding stated, “However, we continue to see females fall behind males in STEM-related attainment” [3, p.13].

Many of the camp participants could be defined as part of the underserved population. Finding #5 of the 2017 ACT report defined underserved using three characteristics: 1) minority by race/ethnicity, 2) first generation in college and 3) low income ( $\leq$  \$36,000/year) [3]. The collected data indicated that underserved students were at a huge STEM disadvantage stating, “Underserved learners lag far behind their peers in the area of STEM preparedness”. It goes on to quantify the findings stating, “Thirty-two percent of ACT-tested students who were not categorized as underserved met the STEM Benchmark, compared to just 11 % of those meeting one criterion, 5 % of those meeting two criteria, and 2 % of those meeting all three criteria”. Finally, they indicate for those with all three criteria they are “sixteen times less likely to be ready for credit-bearing STEM coursework in college than the group of students who are not considered underserved” [3, p.3].

Management Information Systems (MIS), is a STEM field that combines Business courses with Technology courses to help businesses find technical solutions to problems but, is not well known by those outside of the MIS field. Lack of awareness of MIS as a potential field of study was validated by the 2016 ACT® report for North Carolina which indicated only 1% of the students taking the ACT showed any interest in MIS [2]. We believe the percentage is so low due to the lack of knowledge about MIS among middle and high school students. However, since MIS applications address real societal problems which are typically of interest to young females, these applications provide a good method for getting females interested in technology as “a powerful hook for girls and a magnet for women” [1]. Dr. Libeskind-Hadas who spearheaded successful curriculum revisions in the coding classes at Harvey Mudd College indicated “female students tended to think more about their careers in terms of social relevance and how their work could help the world” [16].

This paper begins with a literature review on STEM camps and a description of the methodology used for this study. That will be followed by the data analysis and discussion from the camp surveys and will end with a conclusion. The research question for the study was: *How do the career attitudes of females in grades 7 through 10 change after a MIS STEM camp?*

### **LITERATURE REVIEW**

Prior literature indicates an introduction to STEM education has been an essential tool in attempts to attract, increase interest and bring awareness to STEM careers available for youth. Active hands-on learning and laboratory experience are major solutions in attempts to increase interest in STEM majors [12]. More specifically related to females, researchers have found it can help females to develop more confidence with computers by increasing their computer experiences [9]. In a review of STEM-based literature we found that several STEM programs and studies have been initiated to increase access and exposure to hands-on learning in STEM fields. These programs vary by types of research question, types of programs, program time frames, teaching approaches, and number of participants. Several of these STEM programs were similar to our research in measuring how exposure to STEM fields changes participants awareness, interests or attitudes toward pursuing STEM careers. We will begin with a review of past STEM programs, studies and results. Table 1 summarizes details of these camps.

Camp Host	Length of camp	Grades	# of participants	Results	Research Question
UNC Charlotte [4]	4-week summer camp	High School	67	Positive Impact	To what extent are student attitudes and interest in career areas similar before and after participating in a summer camp experience?
Texas A&M University [10]	2-week summer camps, 2 subsequent year study	Middle School	66	Positive Impact	Study designed to measure participants' interest in, aptitude for, and enjoyment of science, mathematics, technology, and other academic areas.
Rochester Institute of Technology [13]	1-day festival	Middle to High School	203	Positive Impact	1) To stimulate interest in STEM-related careers, and (2) to empower American youth to see themselves as innovators and creators.
University of Oklahoma [8]	Longitudinal study	Middle School	158	Partially Positive Impact	Study longitudinally examined the impact of Fab Lab Tulsa programs on the self-efficacy of school-aged children. Study also examined the correlations between self-efficacy, attitudes toward STEM, perceived impact, and skill attainment among participating students. The hypothesis was that self-efficacy and attitudes toward STEM would increase from pretest to posttest.
Colorado State University [6]	3-day summer camp	Middle School	14	Positive Impact	Study to determine whether inquiry-based activities result in interest levels that are different relative to non-inquiry-based activities.
Middle East Technical University [15]	Two 10-day camps	Elementary School	52	Identified best practices for camps	Study to explore critical design issues for educational robotics training camps and to describe how these factors should be implemented in the development of such camps.

**Table 1: Comparison of STEM Camp Studies**

As indicated in the table, STEM Camp designs vary greatly from institution to institution. Camp design and effectiveness is an important aspect of this study. The review of camps shows that there are many different approaches to camps and no consistent camp design. In an unusual approach, one research study focused on the return on investment of STEM camps and determined both multi-day and single-day programs could motivate students to pursue information technology programs [7]. Moreover, there is no consistent documentation or results to establish the best type of STEM camp design. Each of these camps were open to both males and females and used pre and post camp surveys. Overall, research shows that these types of

camps should provide children with hands-on activities and an environment to practice what they learn to be effective [15].

### METHODOLOGY

This research study is based on a MIS STEM camp that was held in three separate years. In 2017 a non-residential camp was held on three non-consecutive days in the fall of 2017, two Fridays and a Saturday on the university campus. Students were from two middle schools and one High School in the largest Eastern North Carolina (ENC) county, Pitt county. In 2018, a 5-day residential camp was held on the university campus with 12 students and 6 teachers from six ENC counties. The teachers were included in order to spread the STEM camp learning to teachers who could take the learning back to their school districts. In 2019, two 5-day non-residential camps were held on the university campus from three ENC counties. Participants were girls in 7<sup>th</sup>, 8<sup>th</sup>, 9<sup>th</sup> and 10<sup>th</sup> grades.

The 2017 participants were from the public-school system Advanced Via Individual Determination (AVID) program. In 2018, students were recruited by STEM teachers in their respective public-school systems. In 2019, students were recruited from the Boys & Girls Club of the Coastal Plain in several Eastern North Carolina counties. The participants were diverse in race and some were from rural areas. The girls applied for the camp by completing an application which included an essay asking why they wanted to attend. In 2017 the goal was to “reach for the middle” when selecting participants and to include students who otherwise might be overlooked, not the top students and not low, at risk students. This was accomplished through a pre-requisite of selection being participation in the AVID program which seeks to help students “in the middle” become prepared for life after school. In 2018, participants came from six different public-school districts while in 2019 participants were recruited from several Boys & Girls club of the Coastal Plain clubs in three counties.

All camp participants took the same survey both before and after the camp. Parents were asked to take a separate survey, but few were collected due to distribution difficulties. Finally, in order to compare data from the general public to pre-camp survey participants, the survey was distributed to a purchased group of approximately 250 parent/child pairs where the child was from the same grade range as camp participants. The surveys were constructed from publicly available validated surveys from the UNC Friday Institute for this age group and consisted of clear and age appropriate study related questions. Survey questions were designed to measure attitude toward Computer Science and MIS disciplines.

The MIS STEM camp was designed around recommendations from the Cracking the Gender Code report whose extensive research suggests that the key to improvement required sparking the interest of girls in junior high school then sustaining that commitment in high school and into college [1]. The following outlines a three-stage approach recommended by the study:

*Stage 1 – Deepen the girls’ hands-on computing experience*

- The camp taught coding and website building

*Stage 2 – Change girls’ perceptions of computing*

- Interaction with mentors was provided through instructors, college students and alumni who worked in technology fields or were technology/MIS majors

*Stage 3 – Support parents and teachers in understanding the wider role of computing*

- Parents and teachers of participants were provided with take home materials on technology careers and invited to attend camp final project presentations

The “Cracking the Gender Code report” emphasizes that parents and/or teachers often feel ill equipped to inform their children/students about tech careers. The research has found that “Some 46% of parents believe computing and coding are high priorities, but only 25% feel well informed about the benefits of studying computing/coding” [1, p.10].

## DATA ANALYSIS & DISCUSSION

### Demographics

As stated earlier, the camp participants came from several counties in ENC, many of which contain rural areas, they were: Beaufort, Greene, Jones, Lenoir, Martin, Pitt, and Robeson. The number of participants was as follows: 2017 (18), 2018 (11), 2019 (15 and 16) for a total of 60 students. Demographic data for these counties, including Tier level is shown in Table 2. The camp participants were racially diverse; African-American, Caucasian, Hispanic and Native American

County Name & Tier #	*Tier #	% Black	% White	% Hispanic	% of Total Poverty	High School Graduation Rate	*Median Household Income	*% Unemployed	% No HS Diploma	% Attended some college or associate's degree	% Bachelor's degree or higher
Beaufort	1	26%	69%	7%	24.8%	79%	\$41,431	4.66%	15.4%	40.4%	3.1%
Greene	1	36%	52%	15%	26.5%	87%	\$39,738	4.03%	24.9%	38.2%	3.2%
Jones	1	31%	64%	4%	23.0%	81%	\$38,873	4.24%	18.5%	48.2%	2.5%
Lenoir	1	41%	54%	7%	29.2%	78%	\$39,341	4.13%	19.7%	34.8%	2.6%
Martin	1	4%	90%	6%	30.5%	76%	\$35,561	5.19%	16.3%	41.0%	2.9%
Pitt	2	34%	59%	6%	23.5%	78%	\$45,918	4.41%	11.2%	58.5%	9.7%
Robeson	1	24%		8.1%	37.8%	76.4%	34,439	6.08%	23.6%	32.1%	3.5%
US Average		13%	13%	17%	48%	83%		4%	13%		
NC Average		22%	71%	9%	24.8%	87%	\$50,595	4.04%	15.4%		

**Table 2: Participating County Demographics** [14], \*[11]

### Pre and post camp surveys

The research data was collected through pre and post camp electronic surveys for each of the four camps, 2017, 2018 and two in 2019. The pre-camp survey was administered electronically on the first day of camp before any instruction and the post-camp survey was administered electronically on the morning of the last day of camp before the final presentations. The survey questions from the validated survey were selected to measure attitudes toward STEM/MIS and technology subjects as well as STEM career awareness. The pre-camp and post-camp survey count was not the same due to participants not completing the camp or just not taking the post-camp survey. The post-camp and pre-camp surveys contained the same questions in order to measure any change in attitudes towards MIS, Computer Science, STEM, technology and the camp. Due to student privacy requirements, we were unable to match collected pre and post camp responses, and therefore used descriptive statistics to measure and answer the research questions. Questions were constructed using a series of Likert scales and in free form questions.

Data was analyzed by computing mean (M) and standard deviation (SD) scores. Calculated means were used to compare results between before and after camp attitude changes. Standard deviation was used to analyze data distribution normality. Tables were constructed to support the research question. Table 3 compares student interest towards MIS for a college major or a career before and after the camp. Table 4 compares student attitudes towards MIS and Computer Science disciplines before and after the camp. Table 5 compares the level of future interest for STEM subjects before and after the camp.

Table 3 displays the change of interest in MIS for a college major or as a career before and after attending the camp. Using a 5-point Likert scale, where 1 meant not at all interested and 5 meant extremely interested, a slight increase in the mean score from 2.83 to 2.90 was observed. Although other factors may have had an effect, the increase in interest is likely due in part to the information and activities the participants learned or participated in at the camp.

Survey Question	Mean	Std. Deviation
Tell us about your interest in MIS for college or a career - <b>Before</b> attending the camp (Pre-survey)	2.83	1.15
Tell us about your interest in MIS for college or a career - <b>After</b> attending the camp (Post survey)	2.90	1.26

*1-Not interesting at all, 2-Slightly Interesting, 3-Moderately Interesting, 4-Very Interesting, 5-Extremely Interesting*  
**Table 3:** Student attitudes/interest toward MIS for college or a career

A more detailed analysis of student attitudes is found in Table 4. Students were given a series of statements in the survey related to MIS and Computer Science where they were asked to rate the statement on a 5-point Likert scale, where 1 meant Strongly Disagree and 5 meant Strongly Agree. Overall, camp participants entered and left the camp with generally positive attitudes toward Computer Science and MIS ( $M > 3$ , on a 5-point Likert scale). Differences between pre and post surveys varied slightly, with an overall positive increase in attitudes after the camp. However, some interesting results did occur. In Table 4 differences in the statements relating to their confidence in doing MIS related work showed a positive increase while all other statements showed a decrease. Most of the statements with a decrease were related to the importance of MIS to them in their future or as a career. For the Computer Science statements, the results were slightly different. Here they showed a slight increase in in the confidence in their computer science skills but also a slight increase in expecting to use computer science in their future. All other computer science questions showed a decrease between the pre-camp and post-camp surveys. These results may have occurred because participants were able to successfully complete projects where they built websites and coded an 3D animation. Those tasks were expected to increase their confidence in their abilities for that type of work. Also, the groups created remarkable projects, both in topic, creativity and complexity. The results from the other statements are a little more complex. We are unclear why participants did not perceive a need for MIS or computer science in general as a career or in the need for MIS after they left school. Although they were shown examples of females doing technical work and watched demos of the type of work that can be done in a few different fields using technology, the connection did not happen. Perhaps they could not see themselves in those roles or simply had no interest in those areas. Another possibility is that the post-camp survey was given to soon after the end of the camp and these types of realizations sometimes take time. Even though we tried to collect a



second post-camp survey about 4 weeks after the camp we were not successful since many of the participants only went to the Boys & Girls club during the summer. Finally, the results may show no real increase in their attitudes, however, they show an increase in their confidence. We consider this a positive result which may lead some participants to explore technology again given the chance.

The table shows the greatest positive shift was observed in questions about confidence toward MIS. For the question “I am sure of myself when I do MIS” the mean increased from M=3.52 to 3.90, a 0.38 increase. For the question “I know I can do well in MIS” the mean increased from M=3.86 to 4.10, a 0.24 increase. The duplication of survey questions with altered wording was used to ensure fuller measurement of attitude and to ensure students did not answer carelessly. Reverse wording was also used for a similar purpose. Reversed mean values of questions proved to be an appropriate measurement of student attitude. For example, the question “I know I can do well in MIS” M =4.10 (M>3), and the reverse question “I can handle most subjects well, but I cannot do a good job with MIS” M=2.82 (M<3).

MIS	Pre-Camp		Post Camp		Change
	M	SD	M	SD	
Knowing MIS will help me earn a living	3.94	0.95	3.85	1.02	(0.08)
<b>I know I can do well in MIS</b>	<b>3.86</b>	<b>0.81</b>	<b>4.10</b>	<b>0.83</b>	<b>0.24</b>
I expect to use MIS when I get out of school	3.63	0.86	3.58	1.00	(0.05)
I would consider a career in MIS	3.60	0.95	3.54	1.16	(0.06)
<b>I am sure I could do advanced work in MIS</b>	<b>3.59</b>	<b>0.94</b>	<b>3.67</b>	<b>1.14</b>	<b>0.08</b>
I will need MIS for my future work	3.55	0.79	3.45	1.08	(0.10)
<b>I am sure of myself when I do MIS</b>	<b>3.52</b>	<b>0.90</b>	<b>3.90</b>	<b>0.92</b>	<b>0.38</b>
MIS will be important to me in my life's work.	3.52	0.83	3.44	1.07	(0.09)
I can handle most subjects well, but I cannot do a good job with MIS	<b>2.71</b>	<b>1.11</b>	<b>2.82</b>	<b>1.26</b>	<b>0.11</b>
<b>2019</b>					
<b>Computer Science</b>	<b>M</b>	<b>SD</b>	<b>M</b>	<b>SD</b>	<b>Change</b>
Knowing computer science will help me earn a living	4.11	0.90	3.90	1.01	(0.21)
I know I can do well in computer science	3.87	0.84	3.74	1.04	(0.13)
Computer Science will be important to me in my life's work.	3.71	0.95	3.67	1.11	(0.04)
I will need computer science for my future work	3.69	1.03	3.60	1.11	(0.10)
<b>I expect to use computer science when I get out of school</b>	<b>3.57</b>	<b>0.95</b>	<b>3.60</b>	<b>1.03</b>	<b>0.03</b>
<b>I am sure of myself when I do computer science</b>	<b>3.49</b>	<b>0.87</b>	<b>3.92</b>	<b>0.86</b>	<b>0.43</b>
I would consider a career in computer science	3.48	1.09	3.40	1.14	(0.07)
I am sure I could do advanced work in computer science.	3.46	1.00	3.43	1.26	(0.04)
I can handle most subjects well, but I cannot do a good job with computer science.	2.86	1.17	2.82	1.26	(0.04)

Scale: 1 = Strongly Disagree, 2 = Disagree, 3 = Not Agree Nor Disagree, 4 = Agree, 5 = Strongly Agree.

**Table 4:** Student attitudes toward MIS and Computer Science before and after camp sorted by pre-camp mean

Measures of a student's future interest toward taking advanced STEM classes are shown in Table 5. Overall, camp participants entered and left the camp with a generally positive interest level toward taking advanced STEM subjects ( $M > 2$ , on a 3-point Likert scale where 1 meant Not interested and 3 meant Yes interested). There was a positive increase in interest towards the MIS subject (0.06), however, the interest in Computer Science decreased (-0.20). This may have occurred due to the predominantly MIS related activities during the camp. Another study found positive impacts based on including computer experiences they felt specifically had an effect on females. He and Freeman (2010) concluded "computer experiences and computer anxiety fully mediate the effect of gender on general Computer Self-Efficacy" [9, p.7]. This would support our findings of an increase, although small, in the confidence levels before and after camp.

	Pre-Camp		Post-Camp		Change
	M	SD	M	SD	
<i>In the future, do you plan to take advanced classes in:</i>					<i>M(Post-Pre)</i>
Mathematics?	2.28	0.86	2.37	0.88	0.09
Science?	2.36	0.76	2.45	0.79	0.09
Computer Science?	2.25	0.73	2.05	0.86	(0.20)
MIS or Information Systems	2.11	0.74	2.17	0.85	0.06

Scale: 1-No, 2-Not Sure, 3-Yes.

**Table 5:** Student before and after camp future interest for taking advanced classes.

## CONCLUSION

This research study was conducted in conjunction with a MIS STEM camp for girls which included pre and post camp surveys given to the camp participants. Unlike other camps reviewed in the literature section, this camp focused on females only, in an attempt to have some impact on the long-term issue of the critical need for females to enter career paths in under-represented STEM fields such as technology. Similar to prior literature on past camps, this study sought to answer the research question: *How do the career attitudes of females in grades 7 through 10 change after a MIS STEM camp?*

Although the differences in results from pre-camp and post-camp survey questions regarding attitudes towards MIS and STEM subjects were not statistically significant there was a definite increase in the mean scores on many of the questions between the pre-camp and post-camp survey. We observed the girls enjoying the camp experience, one 8<sup>th</sup> grade participant said, "I can't really choose my favorite thing because everyone was very welcoming, and all the projects were really fun." Another participant enjoyed the coding, "Learning how to code has always been interesting to me because if you make one wrong move, it (the application) will totally glitch." Another participant enjoyed collaborating with students she did not know, "My favorite thing about the camp was getting to meet new people and see how coding can turn into your life career." Those of us hosting the camp and teaching the sessions enjoyed interacting with the

girls who asked us many questions about our lives and our work. We believe they opened their minds to new possibilities which is in line with our results showing a positive shift in attitudes. Although the results in attitude shift were not what we expected the data shows an increase in confidence with executing technology. This was a great positive result and leads us to conclude there was enough evidence to continue with this research. This is important since the original goal was to make an impact as suggested by the Cracking the Gender code report [1]. The data and the participant comments indicate there was an impact.

Future research will involve repeating the camp with some minor changes. The camps will be held in the summer where the time frame can be extended to five days instead of three. The surveys will continue to be used so research can be continued and compared across multiple years. However, the post camp survey will be given approximately one month after the camp to see if a change in attitude needs time to be recognized. Finally, we believe including interviews with the campers will improve our ability to analyze the camp results.

We acknowledge limitations around some bias in the results since the participants self-reported on their own activities and are self-selected for participation in the survey. However, this bias is the same as other camps in the literature review and with surveys in general. Also, we believe the camps are successful because our methods align with recommended successful methods identified in the review of several camps in the literature review. We too found the use of experiential techniques with hands-on activities to be effective. We will continue to experiment with and evaluate the camp content to find what works best. Finally, we also used inquiry-based activities such as team projects related to a social issue where participants used their own ideas to develop a website or an animated skit utilizing the skills they learned in the camp. The final group projects were remarkable as indicated by a set of judges from industry and were proof of the knowledge that was gained during the camp.

#### REFERENCES

- [1] Accenture and Girls who Code. (2016). *Cracking the Gender Code*. Accenture.
- [2] ACT Inc. (2017). *The Condition of STEM 2016: North Carolina*. Retrieved September 26, 2018, from [www.act.org/stemcondition](http://www.act.org/stemcondition):  
[http://www.act.org/content/dam/act/unsecured/documents/STEM2016\\_52\\_National.pdf](http://www.act.org/content/dam/act/unsecured/documents/STEM2016_52_National.pdf)
- [3] ACT Inc. (2018, March 1). *STEM Education in the U.S.: Where We Are and What We Can Do 2017*. Retrieved September 27, 2018, from [www.act.org/STEM](http://www.act.org/STEM):  
[www.act.org/content/act/en/research/stem-education-in-the-us-2017.html](http://www.act.org/content/act/en/research/stem-education-in-the-us-2017.html) and  
<http://www.act.org/content/dam/act/unsecured/documents/STEM/2017/STEM-Education-in-the-US-2017.pdf>
- [4] Binns, I. C., Conrad, J., Polly, D., & Algozzine, B. (2016). Student Perceptions of a Summer Ventures in Science and Mathematics Camp Experience. *School Science & Mathematics*, 116(8), 420-429. doi:10.1111/ssm.12196.
- [5] DeNisco, A. (2016, October 16). *Tech's gender gap is getting worse, not better, report says*. Retrieved June 15, 2017, from TechRepublic: <http://www.techrepublic.com/article/techs-gender-gap-is-getting-worse-not-better-report-says/>
- [6] Dillivan, K. D., & Dillivan, M. N. (2014). Student Interest in STEM Disciplines: Results from a Summer Day Camp. *Journal of Extension*, v52 n1 Article 1RIB5.

- [7] Dillon, T. W. (2016). An ROI comparison of initiatives designed to attract diverse students to technology careers. *Journal of Information Systems Education*, 27(2), 105.
- [8] Dubriwny, N., Pritchett, N., Hardesty, M., & Hellman, C. (2016). Impact of fab lab tulsa on student self-efficacy toward STEM education. *Journal of STEM Education : Innovations and Research*, 17(2), 21.
- [9] He, J., & Freeman, L. A. (2010, Summer). Are Men More Technology-Oriented than Women? The Role of Gender on the Development of General Computer Self-Efficacy of College Students. *Journal of Information Systems Education*, 21(2), 203-212.
- [10] Naizer, G., Hawthorne, M. J., & Henley, T. B. (2014). Narrowing the gender gap: Enduring changes in middle school students' attitude toward math, science and technology. *Journal of STEM Education : Innovations and Research*, 15(3), 29.
- [11] North Carolina Department of Commerce. (2019). *2019 North Carolina Development Tier Designations*. Raleigh, NC: NC Department of Commerce. Retrieved from LEAD@nccommerce.com
- [12] President's Council of Advisors on Science and Technology (U.S.), & U. (2012). *Report to the president, engage to excel: Producing one million additional college graduates with degrees in science, technology, engineering, and mathematics*. Washington, D.C: Executive Office of the President, President's Council of Advisors on Science and Technology.
- [13] Quagliata, A. B. (2015). University festival promotes STEM education. *Journal of STEM Education : Innovations and Research*, 16(3), 20.
- [14] U.S. Census Bureau. (2010). *United States Census Bureau 2010 (County Information)*. Retrieved October 20, 2010, from <https://www.census.gov/support/USACdata.html>
- [15] Ucgul, M., & Cagiltay, K. (2014). Design and development issues for educational robotics training camps. *International Journal of Technology and Design Education*, 24(2), 203-222. doi:10.1007/s10798-013-9253-9.
- [16] Xia, R. (2017, January 4). Cracking The Gender Code; college's strategy shift attracts women to computing. *Los Angeles Times*, p. A.1.

Management Skills Desired by College Business Students and Business Employers

By Marjorie L. McInerney

Marshall University

Lewis College of Business

One John Marshall Drive

Huntington, WV 25755

304-696-2675

[mcinerne@marshall.edu](mailto:mcinerne@marshall.edu)

Track: Management, Strategy, Organizational Behavior, Organization Theory, Human Resource Management

Management Skills Desired by College Business Students and Business Employers

---

Workplace jobs are changing with lifetime employment a thing of the past. Students and employees will face a lifetime of multiple occupations/jobs. The primary focus of employment and job change could very well be the skills that people acquire through education and employment. Job skills that are necessary for managers in business has become topic of concern in colleges of business. Beyond initial job skills, colleges should be concerned with developing career planning as an important skill for students and employees to learn (occupational choice/organizational choice; career self-development, choice of job assignment prior to entering the work force and before changing jobs. Many employers are now hiring based on job skills as opposed to educational degree or even work experience (Parento, Kelkar 2000).

The focus of this research was to examine the type of skills students feel they have learned in their undergraduate business programs and what skills they feel deficient in learning. A career skill assessment tool was utilized in three key areas: 1) management skills students feel strong in and skills in which they want further development; 2) how students rate themselves in work characteristics; and 3) the attributes of the ideal job for students.

Data from the career skill assessment tool was analyzed through SPSS looking at frequencies of responses and differences in gender responses. Descriptive analysis will also be used for specific open-ended questions concerning demographic information, work experience and professional achievements. Examples of professional behaviors and autonomy in the job were also gathered. This information along with student goals will also be presented in a comparative and descriptive format.

## **ROLEPLAYING AS A PEDAGOGICAL TOOL TO DEAL WITH COMPLEXITY IN IT PROJECT MANAGEMENT**

Amy J. Connolly, College of Business, James Madison University, 421 Bluestone Drive,  
Harrisonburg, VA 22807, 540-568-8122, conno3aj@jmu.edu

### **ABSTRACT**

The Information Systems 2002 Model Curriculum lists “Project Management and Practice” which includes mastery of the “management of behavioral and technical aspects of the project” [1, p. 31]. The behavioral aspects of a project are tacit or “soft” in nature and generally difficult for students to master from listening to lecture [3]. When asked to perform project management tasks first learned from reading or lectures, students’ first response is “I don’t know what to do or how to do it.” Furthermore, today’s projects continue to increase in complexity and ambiguity, demanding higher levels of critical judgment and improvisation due to their social- and context-dependent nature [2]. In response to these industry needs, I designed roleplaying exercises for the IT project management course. While roleplay exercises are commonly used for training in industry settings, they are less often applied to the IS classroom. What makes these roleplay exercises unique is that they do not involve pairs of students or small isolated groups; rather, the roleplay exercises engage the entire class simultaneously. Novices, in general, are uncomfortable with ambiguity, but an effective project manager deals with ambiguity on a daily basis. Therefore, it is paramount that project management classes subject students to such feelings of ambiguity. The active learning exercises I designed encourage students to embrace ambiguity and complexity and to practice applying project management concepts learned in class, which can improve students’ understanding, communication skills and emotional intelligence. I have used these exercises every fall and spring semester to teach IT project management for the past 5 years. Students report that the exercises help them to better deal with other people on a project and they make the course more enjoyable and the material easier to understand.

### **REFERENCES**

- [1] Gorgone, J., Davis, G. B., Valacich, J. S., Topi, H., Feinstein, D. L., & Longenecker, H. E. (2003). IS 2002 model curriculum and guidelines for undergraduate degree programs in information systems. *Communications of the Association for Information Systems, 11*(1), 1.
- [2] Klein, L., Biesenthal, C., & Dehlin, E. (2015). Improvisation in project management: A praxeology. *International Journal of Project Management, 33*(2), 267–277.
- [3] van der Hoorn, B., & Whitty, S. J. (2019). The five modes of comportment for project managing: Disclosing the tacit in project work. *International Journal of Project Management, 37*(3), 363–377.

## **Student Perceptions of Effective Teaching Methods in an Undergraduate Business School: A Proposed Framework**

### **ABSTRACT**

Some observers have questioned whether institutions of higher education are preparing students in developing employability skills. For the Scholarship of Teaching and Learning (SoTL) to be recognized as crucial intellectual work, faculty must connect theory-based teaching to experience-based learning by continually developing instructional design, pedagogy, and the broader curriculum. Among business schools, efforts are being made to improve curricula by integrating traditional classroom learning and workplace experiential learning. Meanwhile, some concerns have been raised whether traditional assessments actually reflect students' knowledge and skill development (Azevdo et al., 2012). Williams and Williams (2011) identified several key elements which impact students' motivation by improving student learning outcomes. Specifically, challenging assignments (e.g. problem-solving activities or realistic business scenarios) enrich and build students' competency in content learning. Likewise, learners can be motivated through hands-on techniques such as simulations, casework, group projects/presentation and guided discussions. The purpose of this study is to provide a framework for evaluating various classroom practices and the effects on student learning outcomes. For this present study, we surveyed graduating seniors at our institution regarding the types of classroom practices and teaching methods which they had experienced over the previous twelve months, such as group presentations, computer assignments, textbook-based lectures, lecture from other sources, class discussion/debates, "real-world" speakers, brief in-class group projects, practical application of knowledge in a lab setting, service learning, etc. Based on Exploratory Factor Analysis of the data, four components were extracted to provide four dimensions of teaching and learning elements.

### **INTRODUCTION**

Ambrose et al. (2010) define learning as a process that leads to change, which occurs as a result of experience, and increases the potential for improved performance and future learning. Employers have questioned whether institutions of higher education are preparing students in employability skill development. In recent years, concerns have been raised whether traditional assessments actually provide evidence to reflect students' knowledge and skill development (Azevdo et al., 2012). Thus, learning involves the inputs (i.e. prior knowledge and experiences) and student motivation, as well as the ability to organize knowledge and to apply it.

Most pedagogical literature to date has highlighted the importance of various teaching techniques with benefits including the level of student's participation, required knowledge retention, etc. However, debate still exists regarding which teaching techniques are most appropriate for students. In the business pedagogy as well as other fields, it has been highlighted that a shift from passive teaching methods is often necessary. For instance, the importance of active teaching techniques has been noted as business students tend to prefer interactive and concrete pedagogies (Nulty and Barrett, 1996). Thus, many business educational studies have encouraged a pedagogical shift from traditional instructional methods to interactive and experiential learning methods (Frontczak, 1998).

Williams and Williams (2011) identified five key elements which impact student's motivation by improving student learning outcomes. One of the elements indicated that



challenging assignments (e.g. problem-solving activities or realistic situations) tend to enrich and build students' competency in the content learning aspects. Moreover, the authors stated that students can be motivated through hands-on techniques such as simulation, casework, group projects/presentation and guided discussions as a way of enhancing learning via immersion. The purpose of our study is to propose a teaching and learning framework that can be applied for the empirical testing of the impact on student learning of specific classroom teaching methods.

## **LITERATURE REVIEW**

In this section, a literature review of various techniques in classroom practices will be presented. Assessing the impact of classroom practices on learning is essential to the scholarship of teaching and learning. Research on college teaching effectiveness has expanded over the past thirty years as a result of new discoveries in brain research and learning, and from increasing pressures from policy makers regarding the value of an undergraduate degree (Nilson, 2016; Svinicki and McKeachie, 2011).

Project-based learning improves students' ability in problem-solving, creativity, responsibility, communication, and self-direction (Wurdinger and Qureshi, 2015). Such project-based learning can be accomplished in individual or group format. For students to be more cooperative and experiential, teaching methods which utilize individual or group projects have been frequently used in business schools. Compared to individual projects, the aim of group projects is to improve communication skills and the problem-solving abilities by facilitating interaction between students. Such interaction allows students to obtain knowledge from each other (Hwang et al., 2005). Additionally, other positive outcomes throughout cooperative learning are typically achieved. Smith and Waller (1997) compared the differences between traditional learning and cooperative learning. Traditional learning has lower interdependence, individual accountability, little commitment to other students' learning, whereas cooperative learning leads to highly positive interdependence, accountability to the group, and improved teamwork skills.

In a typical class, the faculty member approaches teaching as a means to dispense knowledge to the students by way of lectures, notes on slides, and infrequent probing questions. Fink (2013) notes that this approach consists of lecturing based on ones understanding of the subject, along with leading whole-class discussion with the class members. Students are expected to receive knowledge based on listening, taking notes, and participating in discussions. Traditional instructional methods are teacher-centered as opposed to student-centered. For several decades, a growing body of research in the cognitive sciences has focused on how learning occurs (Svenicki, 2010) and demonstrates that students learn more from active teaching methods than they do from traditional methods (Bonwell and Eison, 1991).

Watts and Baker (2008) surveyed U.S. academic economists to investigate how economics is taught in four different types of undergraduate courses at postsecondary institutions. The goal of the study was to identify any changes in teaching methods that occurred over the previous decade as faculty were being challenged to utilize more innovative teaching methods instead of student-centered methods. The results showed that although standard lectures and presentations were still widely used, active methods became more commonly used.

Raja and Najmonnisa (2018) studied business communications classes to compare traditional teaching methods with the Case Study Method. The results indicated that experiential learning methods improved students' communication skills more effectively than did the traditional method. Beginning with traditional modes such as lecture and assigned readings, faculty

increasingly employ a wider variety of instructional practices to improve learning. In addition to lectures and assigned readings as common teaching methods that are considered particularly effective for certain purposes (Svinicki and McKeachie 2011), multiple authors (Nilson 2016; Pascarella and Terenzini 2005) have discussed the benefits of additional teaching methods such as in-class discussions, case studies, project-based learning, inquiry-guided learning, in-class use of real-world speakers, and various other in-class teaching methods utilizing experiential learning.

## METHODOLOGY

### Data Collection

From the above literature review, it is evident that a majority of classroom teaching practices will likely have a positive impact on learning in at least some situations. Eighteen different teaching methods (case analysis, simulations, group presentations, real world project completed in a group, etc.) were identified from the literature review to develop the framework for this present study. These various teaching methods were listed for student responses via a Likert scale (1= Not included in any of my classes over the past year to 5= Included in all of my classes). The survey asked graduating business students to reflect on their experience involving these eighteen teaching methods that they had encountered in their classes over the past twelve months. The reason for including only the last twelve months is that the students take a majority of their upper division courses in their senior year. The data was compiled from Spring 2017 to Spring 2019 in an AACSB accredited public university in the US. The total sample was comprised of 364 business students in their final semester capstone course. Table 1: Data description lists the number of students according to major and gender.

Table 1: Data description

Major	No. of Students	Male	Female
Accounting	67	30	37
Economics	11	8	3
Finance	68	48	20
Information Systems	25	22	3
Management	127	81	46
Marketing	66	33	33
Total	364	222	142

### Data Analysis and Results

The principal component analysis (PCA) technique was initially utilized for this present study by using Promax rotations. We examined the sample size of 364 observations with 18 items (variables) which meet the minimum requirement for the exploratory factor analysis. The cut point is set at 0.4. The output for Kaiser-Meyer-Olkin (KMO) of 0.849 satisfied the PCA. Kaiser criterion of eigenvalues demonstrates that total four factors/components are extracted from the data to explain 56.9% of total variance. The table of Rotated Component Matrix (Promax) further indicated the extraction of four factors/components. The name of each factor is provided in Table 2: Descriptive Statistics.

Factor 1 is comprised of five items each with positive values: “Field Trips” (0.866), “Application of Knowledge through Service Learning” (0.771), “Practical Application of

Knowledge in a Lab Setting” (0.707), “Reading Assignments from Academic Journals” (0.687), and “Real World Speakers” (0.584). These items revealed the various teaching methods that allow students to apply what they have learned in the classroom. We will name factor 1 “*Application of Knowledge.*”

Factor 2 contained four items of “Brief In-Class Project(s) that You Completed in a Alone” (0.873), “Brief In-Class Project(s) that You Completed in a Group” (0.824), “Real World Project(s) that You Completed in a Group” (0.764), and “Real World Project(s) that You Completed alone” (0.710). Students indicated positive experiences regarding classroom practices involving projects. Thus, we will name factor 2 “*Project*”.

Factor 3 offered three items in “Lecture from Text” (0.828), “Lecture from Other Sources” (0.769), and “Class Discussion / Debate” (0.709) which presents more traditional classroom practice techniques. We name factor 3 “*Traditional Teaching Methods*”.

Factor 4 contained two items in “Case Analysis” (0.946) and “Simulation” (0.741) as one construct. We named factor 4 “*Case/Simulation.*”

Four items were dropped from the analysis (Group presentations, Presentations by you alone, Writing assignment, and Computer Assignment) due to high cross loading or low item loading. Table 2 indicated the mean, Cronbach’s Alpha, and the item loading for each valid item. The Cronbach’s alpha for “Application of Knowledge”, “Project”, “Traditional Teaching Methods”, and “Case/Simulation” are 0.806, 0.820, 0.687, and 0.678, respectively. Cronbach’s reliability test is often used to examine the fit of multiple items to measure for one underlying construct. The general guideline for Cronbach’s alpha is often defined as at least 0.6 in the lower limit for reliability (Nunnally, 1978; Flynn et al., 1990).

Table 2: Descriptive Statistics

Items	Mean	Item Loading
Application of Knowledge (Cronbach’s Alpha=0.806)		
Field Trips	1.57	0.866
Application of Knowledge through Service Learning	2.34	0.771
Practical Application of Knowledge in a Lab Setting	2.33	0.707
Reading Assignments from Academic Journals	2.59	0.687
“Real World” Speakers	2.37	0.584
Project (Cronbach’s Alpha=0.820)		
Brief In-Class Project(s) that You Completed in a Alone	3.14	0.873
Brief In-Class Project(s) that You Completed in a Group	3.17	0.824
“Real World” Project(s) that You Completed in a Group	2.77	0.764
“Real World” Project(s) that You Completed alone	2.62	0.710
Traditional Teaching Methods (Cronbach’s Alpha=0.687)		
Lecture from Text	4.09	0.828
Lecture from Other Sources	3.49	0.769
Class Discussion / Debate	3.57	0.709
Case/Simulation (Cronbach’s Alpha=0.678)		
Case analysis	3.10	0.946
Simulations	2.66	0.741

## CONCLUSION

This present study provides a framework for determining student perceptions of the type of teaching methods and the association with learning performance. From the literature review, various teaching techniques such as direct or indirect methods can affect student learning outcomes. These teaching methods covered a broad range of activities, ranging from traditional classroom lectures to real-world internship opportunities. Four dimensions of teaching methods were identified from the present study: application of knowledge, projects, traditional teaching methods, and cases/simulations. For future studies, we will attempt to determine if these four dimensions of teaching methods tend to improve student's learning performance (i.e. GPA) or their level of satisfaction with their overall learning experience in the college of business.

## REFERENCES

- Ambrose, S. A., Bridges, M. W., DiPietro, M., Lovett, M. C., & Norman, M. K. (2010). *How learning works: 7 research-based principles for smart teaching*. San Francisco, CA: Jossey-Bass.
- Azevdo, A., Apfelthaler, G., & Hurst, D. (2012). Competency development in business graduates: An industry-driven approach for examining the alignment of undergraduate business education with industry requirements. *The International Journal of Management Education*, 10(1), 12-28.
- Bonwell, C.C. and Eison, J.A. (1991). Active learning: Creating excitement in the classroom. *ASHE-ERIC Higher Education Report*, 1. Washington, D.C.: George Washington University.
- Fink, L. D. (2013). *Creating significant learning experiences: An integrated approach to designing college courses*. (2<sup>nd</sup> ed.) Jossey-Bass.
- Flynn, B.B., Sakakibara, S., Schroeder, R.G., Bates, K.A., & Flynn, E.J. (1990). A framework for quality management research and an associated measurement instrument. *Journal of Operations Management*, 11(4), 339-366.
- Frontczak, N. T. (1998). A paradigm for the selection, use and development of experiential learning activities in marketing education. *Marketing Education Review*, 8(3), 25-33.
- Hwang, N. C. R., Lui, G., & Tong, M. Y. J. W. (2005). An empirical test of cooperative learning in a passive learning environment. *Issues in Accounting Education*, 20(2), 151-165.
- Nilson, L. B. (2016). *Teaching at its best: A research-based resource for college instructors* (4<sup>th</sup> ed.). San Francisco: Jossey-Bass.
- Nulty, D. D., & Barrett, M. A. (1996). Transitions in students' learning styles. *Studies in higher education*, 21(3), 333-345.
- Nunnally, J.C. (1978). *Psychometric Theory*. McGraw-Hill, New York.
- Pascarella, E.T. & Terenzini, P.T. (2005). *How college affects students: A third decade of research* (2<sup>nd</sup> ed.). San Francisco, CA: Jossey-Bass.
- Raja, F. U., & Najmonnisa. (2018). Comparing traditional teaching method and experiential teaching method using experimental research. *Journal of Education & Educational Development*, 5(2), 276.
- Smith, K. A., & Waller, A. A. (1997). Cooperative learning for new college teachers. *New paradigms for college teaching*, 185-209.
- Svinicki, M. & McKeachie, W.J. (2011). *McKeachie's teaching tips: Strategies, research, and theory for college and university teachers* (13<sup>th</sup> ed). Belmont, CA: Wadsworth Cengage Learning.

- Svinicki, M. D. (2010). Student learning: From teacher-directed to self-regulation. *New Directions for Teaching & Learning*, 2010(123), 73–83.
- Watts, M., & Becker, W. E. (2008). A little more than chalk and talk: Results from a third national survey of teaching methods in undergraduate economics courses. *Journal of Economic Education*, 39(3), 273–286.
- Williams, K. & Williams C. (2011). Five key ingredients for improving student motivation. *Research in Higher Education Journal*, 12, 1–23.
- Wurdinger, S., & Qureshi, M. (2015). Enhancing college students' life skills through project based learning. *Innovative Higher Education*, 40(3), 279-286.

## **TEACHING INTRODUCTORY DATABASE: FOCUSING ON THE USER PERSPECTIVE**

Leigh A. Mutchler, College of Business, Computer Information Systems & Business Analytics, James Madison University, 421 Bluestone Drive, Harrisonburg, VA 22807, mutchlla@jmu.edu

### **ABSTRACT**

A basic understanding and appreciation of databases is important to all business students. Relational database concepts are often covered within an introductory Information Systems (IS) course, a course frequently included as part of the business core and as such one that addresses the database knowledge needs of not just IS students but of all college of business majors. This abstract represents a work in progress that argues that when introductory database concepts are taught to all business majors, the focus should be from the database user perspective.

Database data retrieval and reporting skills are more important to database professionals than are the skills of designing or building [1]; therefore, the coverage of introductory database concepts in an introductory IS course should focus on query development. The course will include coverage of relational database concepts and structures, and ideally will also include hands-on activities because they contribute to learning [2] which is particularly important when learning about technologies. The active learning techniques that accompany introductory database concepts often consists of designing and building a relational database (usually with Microsoft Access), followed by simple query, report, and form development. Those majoring in IS will find these activities particularly meaningful and relevant to their future careers, but is that equally true for the non-IS student? Business students other than those majoring in IS are not expected to have a career where they will design and build a database. They will, however, have a career where they will regularly *use* a database. The greatest benefit for all business majors, including IS majors, is to learn to translate business questions into database queries which will in turn help them to more fully understand and appreciate the relational database. These activities will also aid students in the development of problem solving skills and increase understanding of business processes. The goals of this work in progress include documenting the teaching method, sample assignments, and collecting and presenting evidence of student perceptions.

### **REFERENCES**

- [1] R. J. Campbell, "Database Design: What HIM Professionals Need to Know," *Perspectives in Health Information Management*, vol. 1, no. 6, Aug. 2004.
- [2] L. D. Fink, "A Self-Directed Guide to Designing Courses for Significant Learning," *Jossey-Bass*, pp. 1-34, 2003.

**TEACHING THE IMPACT OF SUPPLY CHAIN ON PROJECT MANAGEMENT: AN EXPERIENTIAL EXERCISE AT A VINTAGE PORSCHE RESTORATION SHOP**

Dr. William Ritchie - James Madison University  
Mr. Cole Scrogam - Madison Automotive Apprentices Program  
Mr. Noah Salvato - James Madison University  
Dr. Ali Shahzaad - James Madison University

**Abstract**

Students in traditional business programs often engage in some form of project management (PM) course whereby students learn the intricacies of working with popular PM software platforms. However, associated PM software platform exercises often focus on analysis techniques using static data. In these situations, it is difficult for students to comprehend the complex nature of executing their project management plans in the “real world.” This experiential case study is designed to provide students with first-hand knowledge regarding the highly volatile relationship between supply chain efficiency and PM. In this experiential exercise, students review a brief case-study of Madison Automotive Apprentices Program (MAAP), a nonprofit corporation engaged in restoring vintage Porsches. After studying the traditional project management documents in the classroom, students then engage in a site visit to MAAP and participate in question and answer sessions with the founder and CEO to learn about supply chain challenges that impact PM implementation. This exercise illustrates how local firms in the automotive industry serve as an ideal teaching context for integrating complex concepts such as supply chain and PM.

## INTRODUCTION

*“We have students with different majors and clients from different walks of life. The one thing that connects them is cars...”* - Cole Scrogam, MAAP CEO

Cole Scrogam, CEO of Madison Automotive Apprentice Program (MAAP), just finished speaking with a new client regarding the prospect of adding a new restoration project to his work-in-process. The client requested the restoration of a vintage 1973 Porsche 911 engine. During the phone conversation, the client had indicated a hard deadline for the rebuild of 60 days – and Cole was inclined to confirm this timeline – however, as Cole hung up the phone, he thought about the complicated processes of disassembly, cleaning, sourcing replacement parts, and reassembly. Foremost on his mind, however, were two key issues related to sourcing. First, client desired a specific type of performance piston be installed in the engine. Due to the age of the engine and limited suppliers, fulfillment of this request presented some uncertainty. Second, without having opened the engine case, there is a great deal of uncertainty regarding the condition of the internal engine parts.

As Cole considered this potential project, he knew that he would have to check the details of his assembly timeline to determine the feasibility of his customer’s request – which might add significant sourcing and shipping delays. Cole knew that a typical 911 engine restoration required about 50 man-hours – assuming all parts were on-hand and all project steps go exactly as planned. However, the inclusion of a specialty piston and uncertainty within the engine could potentially layer additional machine work, parts, and labor to the standard process.

To gain a better perspective on the timeline for this project, he loaded the various assembly steps into MS Project. Once loaded in MS Project, it would be easier to evaluate the impact of critical supplies on the assembly process. His primary concern was that the sourcing and delivery of the appropriate parts may significantly impact the build-out timeline. He knew his project completion timeline estimates had to be as accurate as possible, since contacting the client and requesting an extension for the rebuild was not an option and restoration accuracy and prompt service were a key component of MAAP’s competitive advantage. To begin the analysis process, Cole compiled the key steps in the engine assembly process (See Table 1 for sample assembly process). He also created a draft project timeline and Gantt chart (see Figure 2 and Figure 3, respectively). Using this information as a basis, he considered what the next steps might be.



**Table 1**  
**Assembly Tasks**

ID	Task Mode	Task Name	Duration
1	✦	<b>Porsche 911 Engine Assembly Project</b>	<b>11175 mins?</b>
2	✦	<b>Disassembly and Preparation</b>	<b>10560 mins?</b>
3	✦	Disassemble Engine	480 mins?
4	✦	Clean Engine Parts	180 mins
5	✦	Inspect Parts for Excessive Wear	60 mins
6	✦	Order Replacement Parts	120 mins
7	✦	Machine Heads	10080 mins
8	✦	Machine Bearing Surfaces	5000 mins
9	✦	Retap Loose Studs	1500 mins
10	✦	<b>Prepare Engine Bottom End</b>	<b>3640 mins</b>
11	✦	Mount engine to stand	60 mins
12	✦	Install main bearings	120 mins
13	✦	Remove machine shop shavings from case	60 mins
14	✦	<b>Connecting Rod Preparation</b>	<b>4760 mins</b>
15	✦	Inspect stretch bolts and lubricate connecting sur	30 mins
16	✦	Fit connecting rods to crankshaft	120 mins
17	✦	<b>Intermediate Shaft and Oil Pump</b>	<b>1775 mins</b>
18	✦	Fit timing chains to intermediate shaft	20 mins
19	✦	Complete oil bypass modification	120 mins
20	✦	Prepare the main bearing	20 mins
21	✦	Lubricate bearing surfaces that come in contact w	30 mins
22	✦	Lubricate the main bearings and crankshaft journa	45 mins
23	✦	<b>Crankshaft Assembly</b>	<b>60 mins</b>
24	✦	Install crankshaft assembly into the engine case	30 mins
25	✦	Center connecting rods	20 mins
26	✦	Turn #8 bearing until gears mesh	10 mins
27	✦	Install rear main seal	20 mins
28	✦	<b>Prepare to join case halves</b>	<b>180 mins</b>
29	✦	Lubricate internal surfaces of case halves	30 mins
30	✦	Lube connecting rods	45 mins
31	✦	Lube crankshaft	15 mins
32	✦	Lube inside of oil pump	15 mins
33	✦	Lube helical mating gears	15 mins
34	✦	Apply Loctite to both case half mating surfaces	30 mins
35	✦	Guide connecting rods into the cylinder holes	45 mins
36	✦	Tap case halves together	45 mins
37	✦	Install central case throughbolts	45 mins
38	✦	<b>Mount engine case accessories</b>	<b>480 mins</b>
39	✦	Install oil pressure sending unit	45 mins
40	✦	Install thermostat	30 mins
41	✦	Install case breather top	30 mins
42	✦	Install oil sump plate screen	30 mins
43	✦	Repair any pulled studs on the outer case	60 mins
44	✦	Install the distributor drive gear	20 mins
45	✦	Install chain guides	30 mins
46	✦	Install chain ramps	480 mins
47	✦	<b>Preparing pistons and cylinders</b>	<b>6660 mins</b>
48	✦	Check first combustion ring (close to .012)	60 mins
49	✦	Check second combustion ring (close to .010)	60 mins
50	✦	Install rings on pistons (noting the bevel facing up)	120 mins
51	✦	Position rings on pistons at 180 degree angles	30 mins
52	✦	Clean cylinder walls with Automatic transmission	60 mins
53	✦	Clean cylinder with a lint-free cloth	30 mins
54	✦	Lubricate the surfaces of the connecting rods	60 mins
55	✦	Lubricate the wrist pin	45 mins
56	✦	Cover engine studs with a smooth cloth to avoide	10 mins
57	✦	Push pins through pistons	60 mins
58	✦	Align piston rings	60 mins
59	✦	Lubricate pistons	30 mins
60	✦	Use ring compressor to fit pistons into cylinder	120 mins
61	✦	Check piston deck height	120 mins
62	✦	Rotate crankshaft to install all pistons	60 mins
63	✦	<b>Cylinder head installation</b>	<b>345 mins</b>
64	✦	Install barrel nuts on head studs	60 mins
65	✦	Install the heads on the cylinders (Intake valves or	120 mins
66	✦	Put Loctite on area between head and cam hous	30 mins
67	✦	Install air deflectors	60 mins
68	✦	Intall oil return tubes with o-rings	60 mins
69	✦	Check valve opening distances and ensure proper	60 mins
70	✦	Install camshaft housings	45 mins
71	✦	Torque the head bolts	60 mins
72	✦	<b>Camshaft and valve train</b>	<b>90 mins</b>
73	✦	Lubricate camshaft surfaces	30 mins
74	✦	Adjust timing chain	60 mins
75	✦	<b>Chain correlation</b>	<b>135 mins</b>
76	✦	Correlate the chains	60 mins
77	✦	Attach crankshaft pully	30 mins
78	✦	Set Top Dead Center (TDC)	45 mins
79	✦	<b>Camshaft timing</b>	<b>45 mins</b>
80	✦	Set camshaft timing	45 mins

**Figure 2**  
**Project Timeline**

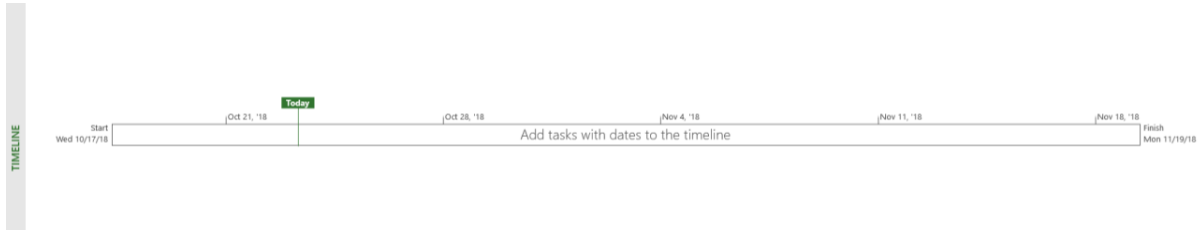

**Figure 3**  
**Abbreviated Gantt Chart**

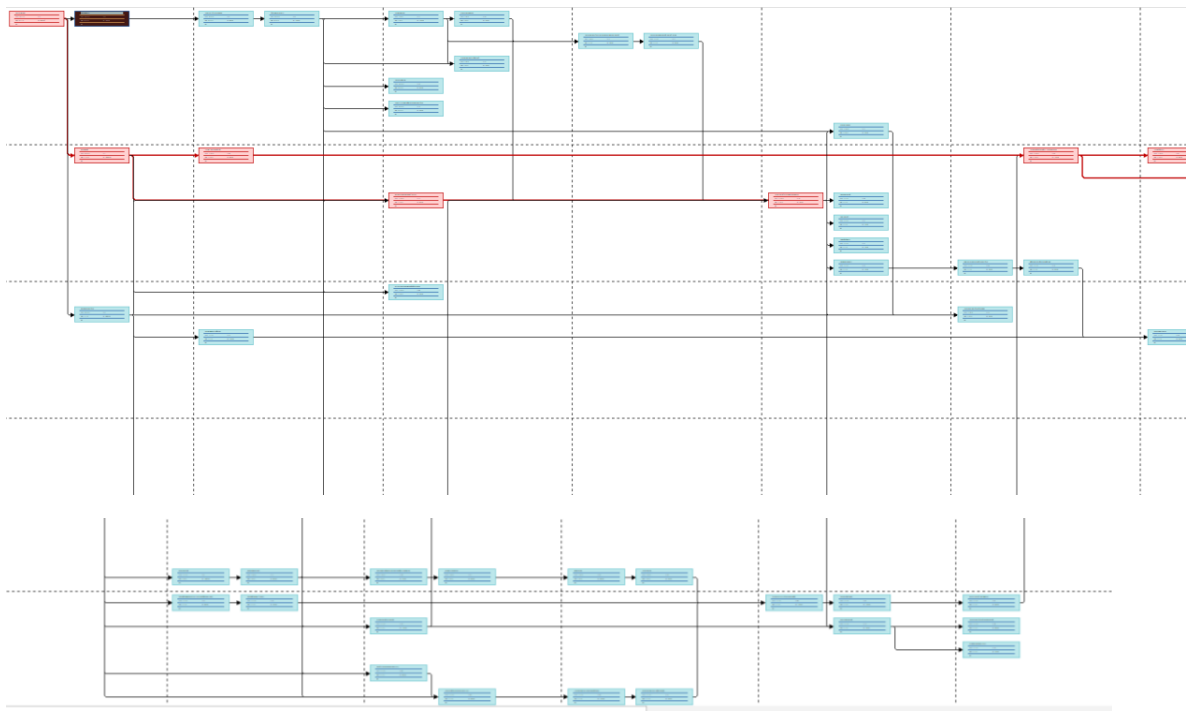

**MAAP History**

MAAP is a non-profit organization that exists to share the love of the automobile with the next generation. MAAP provides educational opportunities for automotive restoration/preservation and motorsport experiences. It accomplishes this by creating cooperative opportunities between auto manufacturers, higher education institutions, vintage Auto Clubs, and enthusiasts. While it specializes in restoring Porsches, vintage Volkswagens, and other classic automobiles, MAAP also consults with car owners who need expertise on how to work on their own vehicles.

## **Automotive Restoration Industry Background**

The automotive industry plays a significant role in the overall success of the United States' economy. With more than \$18 billion in spending, including research and development, it employs more than 1.7 million individuals and contributes about 3.5 percent to the Gross Domestic Product (GDP). Within this automotive context, engine rebuilding and remanufacturing accounts for \$2.6 billion in revenues each year (Sanders, 2018). In the broadest sense, this specialty industry primarily focuses on services (suppliers) offered for individuals (consumers) facing automotive decisions related to either repairing/replacing automotive components. On the supply side, the increasing complexity of engines and inflationary pressures on the prices of component parts places significant constraints on firm profitability. For example, the demand for recycled metals and the countervailing forces of hazardous materials is increasingly placing limits the amount of potential raw materials on the market for engine rebuilds and remanufacture.

### **Daily Drivers Versus Restoration**

The consumer side of the engine rebuild industry is comprised primarily of two types of buyers, 1) daily drivers and 2) restoration and custom engine shops. Activity among the daily-drivers is contingent on macro-economic forces and disposable income. For example, individuals (and/or their mechanics and parts suppliers) undertake engine rebuilds and remanufacture when it is more cost effective to do so. In these cases, the buyer may bypass the rebuild process and simply opt for new equipment, particularly economic cycles when cash is more readily available.

By contrast, restoration and custom engine-build shops have very different market forces driving demand. The engine restoration market is a unique niche within the industry. The buyers are typically remanufacturing an engine as part of a larger automotive restoration project or specialty application (such as racing). In this case, the question of cost/benefit of engine restoration rests more with the overall return on investment (ROI) of the final value of a classic or race-car restoration, than with the functionality of returning a car to "daily driver" status. Thus, the demand for engine restoration and associated profit margins for these services are often significantly higher than mainstream engine re-builds project. For example, the value of a highly desired vintage sportscar will be significantly discounted if the engine is not in a comparable restoration states as that of the external car body. Therefore, it is often taken as a given that engine rebuilders in this market will proceed with a mechanical restoration, despite high costs.

### **The Suppliers**

Due to the specialized nature of Porsche engine restoration, there is a limited number of qualified suppliers. However, due to Cole's extensive industry experience, MAAP has many parts providers that can be relied upon for excellent quality and service. These suppliers have a broad geographic distribution. (See Figure 1 below)

**Figure 1**  
**Geographic Distribution of Component Suppliers**



### Porsche Engine History

In 1948, the chairman of Volkswagenwerk in Wolfsburg, Germany asked Ferry Porsche of Porsche Konstruktionen GmbH in Karinthia, Austria to build a sports car that was based upon the Volkswagen (Aichele, 1999). The engine design for this new sports car would closely follow the specifications of the four-cylinder, air-cooled Volkswagen engine. The advantages of the air-cooled design were its relatively low maintenance and light weight (e.g. compared with liquid-cooled engines which require an entire system of water pumps, heat exchangers, and extra

hoses). This arrangement with Ferry Porsche marked the beginning of using the air-cooled “flat” engine design in a variety of Porsche models, including the Porsche 356, 912, 911, and the 914. Implementation of this engine design would continue until 1998, when the air-cooled design would be replaced with a conventional water-jacket cooling method. During the 50 years of production, the elegant, yet simple design of the Porsche air-cooled engine has created a large following of sports car enthusiasts who value the quality engineering and design of the Porsche sports car.

Today, this fascination with Porsche’s air-cooled engine design has supported a niche market of car restoration. The Porsche restoration market is supplied by a variety of companies, nationally and internationally, that specialize in warehousing authentic car components (See Figure 1). These vendors supply parts for the automobile body, the interior, and the engines. From the perspective of the restoration specialists, the challenge was to source rare parts from these vendors at a reasonable price, while assuring the quality of the parts and timely delivery.

### **Teaching Plan**

The effectiveness of this exercise is optimized when PM professors collaborate with supply chain professors to deliver a similar activity. We began this exercise by first distributing the above case study to students prior to the site visit. In class, prior to the site visit, it is beneficial to discuss with the students the lessons they have learned from previous PM classes and assignments. This is a good time to discuss with students supply chain relationships with the implementation of PM plan. For example, it is useful to ask the students to specify whether they have considered supply chain impacts on PM plans. Students often reflect on mention of the relationships in previous classes, but typically lack experiential activities.

Madison Automotive Apprentices Program is only a short 15-minute drive from our campus. We would recommend identifying a local automotive business that is less than 30 minutes from campus, in order to maximize class time. Additionally, the supply chain course in which this exercise was implemented was delivered once-per-week in a face-to-face format, on a Monday night from 7 – 9:30 p.m. The long class session was particularly conducive to site visits.

Once on-site at the automotive restoration facility, students are provided about 15 minutes to explore the facility (Figure 4). Then students are gathered to meet the owner, Cole Scrogam. The owner provides the students with a brief background of the facility and then directs student to the Porsche 911 engine that is currently in the process of restoration. In the presentation, Cole refers to a large-format Gantt chart that specifies all the steps in the restoration process. Then Cole directs student attention to newly plated nuts and bolts to illustrate the level of detail required for a quality restoration project. He also explains how challenging it is to obtain certain parts, such as period-correct pistons. In this presentation it becomes obvious to the students that many of the PM projects in classroom exercises assume a relatively consistent and predictable supply of components.

**Figure 4**  
**Students Exploring MAAP**



**Class Debrief Questions:**

1. How are project management software tools complementary to sourcing activities in supply chain management?
2. Identify specific ways in which sourcing decisions and outcomes impact project management completion.
3. What strategies do managers employ to hedge against issues with suppliers?
4. What industries also face similar supply chain sourcing issues as automotive restoration?
5. What additional skills do you, as a student, need to acquire to better understand the relationship between supply chain management and PM?
6. What strategies might help Cole manage the uncertainties associated with vintage part supply uncertainty?
7. What software tools might enable efficient management of the uncertainties associated with vintage parts supplies?



## Television? Is It Worth Watching?

Sara Bliss Kiser, College of Business Administration, Alabama State University, 915 S. Jackson Street, Montgomery, AL 36104, 334-546-1136, [skiser@alasu.edu](mailto:skiser@alasu.edu)

### ABSTRACT

The use of reality television in the classroom is not new. *Survivor* has been utilized to study economics and strategy; while *The Apprentice* was used to discuss every topic covered in a business curriculum. However, in recent years, there has been a myriad of new business programming. *Shark Tank*, *The Profit*, and *Undercover Boss* are some of the options which can be utilized. Outside of those “business-oriented” options, there are others such as *Brain Games* and *Mysteries at the Museum*. This presentation and subsequent paper will examine how to use a variety of these shows to bring textbook topics to “life” for students.

### REFERENCES

- ABC. (n.d.a). *Shark Tank Episode Guide, Season 8*. Retrieved March 20, 2017, from <http://abc.go.com/shows/shark-tank/episode-guide>.
- ABC (n.d.b). Shark Tank: Meet the cast. Retrieved March 20, 2017, from <http://abc.go.com/shows/shark-tank/cast>
- Acchiardo, C-J., Al-Baharani, A., Patel, D., & Sheridan, B. J. (n.d.). *Dive In! Tips for teaching economics through Shark Tank*. Retrieved March 20, 2017, from <https://www.aeaweb.org/conference/2015/retrieve.php?pdfid=1226>
- Burns, L-M. (n.d.). *Shark Tank Analysis*. Retrieved March 20, 2017, from <http://casn.berekely.edu/curriculum-detail.php?c=600>
- CBS. (n.d.). *Undercover Boss: About Undercover Boss*. Retrieved March 20, 2017, from [http://www.cbs.com/shows/undercover\\_boss/about/](http://www.cbs.com/shows/undercover_boss/about/)
- King-Adzima, K. A. (2008). Using the ‘The Apprentice’ to teach a managerial economics course. *International Review of Economics Education*, 56-75.
- Kiser, S. B. (2006). Classroom Tools For Teaching Ethics: The Apprentice and the “Bunny Book” Can They Work? Can Similar Materials Work For You and Your Classes In General? *SEInforms Conference Proceedings*, 253-262.
- Kiser, S. B., & Haskell J. (2005). Is “Reality” TV useful in the classroom? A look at *The Apprentice’s* first season. *SEInforms Conference Proceedings*.
- Layton, S. (2015, May 11). *How to think outside the box with entrepreneurship lesson plans*.



Retrieved March 20, 2017, from

<http://www.aeseducation.com/blog/2015/05/entrepreneurshiplesson-plans>

Lemonis, M. (n.d.). *About Marcus*. Retrieved March 20, 2017, from

<http://www.marcuslemonis.com/pages/about-us>

Mixon, F. G., Jr. (2001, November-December). Cartel (in)stability on *Survivor* Island. *Journal of Education for Business*, 77(2), 89-94.

Nisen, M. (2013, September 10). Why A Self-Made Millionaire Puts His Money On The Line For Struggling Small Businesses. *Business Insider*. Retrieved March 20, 2017, from

<http://www.businessinsider.com/marcus-lemonis-the-profit-investment-2013-9>

Sandoval, M. (2014, December 26). *Shark Tank Assignment*. Retrieved March 20, 2017, from

<http://www.familyconsumersciences.com/2014/12/shark-tank-assignment/>

Weiss, J. (2004, December 19). Hanging on: Ratings for some of reality TV's biggest shows have slipped this season, but don't expect the format to lose its grip any time soon. *Boston Globe*, N1.

## **ABSTRACT ONLY**

In this paper, we study the performance of students enrolled in a fully online class. We define procrastinators as those who submit their exam within the last 5% of the allotted time. Our findings show that there is a significant difference between the academic performance of the procrastinators and the "punctuals": procrastinators' exam scores are significantly lower than those of the punctuals. We also share these results with the entire class of almost 200 students through an online announcement on the class website. Our follow-up analysis shows that the proportion of procrastinators decreases; in addition, the performance of procrastinator-cum-punctuals improves significantly.

## THE VALUE OF CASE COMPETITIONS AND THEIR INTANGIBLE BENEFITS

Gwen F. Hanks, Innovative Business Solutions, Athens, GA, 706-424-5989,  
gwen.hanks08@gmail.com

Mario Zanio, College of Business Administration, Alabama State University, 915 S. Jackson  
Street, Montgomery, AL 36104, 850-602-0843, mzaino@alasu.edu

Sara Bliss Kiser, College of Business Administration, Alabama State University, 915 S. Jackson  
Street, Montgomery, AL 36104, 334-546-1136, [skiser@alasu.edu](mailto:skiser@alasu.edu)

### ABSTRACT

In recent years, case competitions have grown from niche activities at some universities to promote their brand into international events embraced by multinational corporations in search of future talent. The case method has been a valuable teaching method in many disciplines. Cases represent enhanced experiential learning tools designed to involve students as decision-makers in the application of relevant concepts to real situations, problems, and challenges through active analysis. In many situations, cases and case competitions add something intangible that students can engage with, while enhancing their world view. The added-value for business school students is that participants learn and apply skills that can be utilized for problem-solving and decision-making in the “real world.” Many benefits are acquired via this active learning method, some visible, others less tangible but just as valuable. This article reviews case competitions as valuable global events useful to multiple constituencies, such as faculty members, students, researchers and corporate sponsors, and business schools (as a measure of assurance of learning) all intent on deriving rewards from these events. The authors present exploratory research and an overview of opportunities to showcase student through the evolving skills and benefits associated with case competitions.

**Keywords:** Assurance of Learning, Case Competitions, Case Method, Experiential Learning, Edutainment, Intangible Learning Benefits

### REFERENCES

Asplund, C.J., & Bengtsson, L. 2010. University-Industry Collaboration: A Conceptual Learning Framework. *Proceedings of the International Conference on Organizational Learning, Knowledge and Capabilities OLKC* (June 4-6, 2010) Boston MA.

Barkley, E.F., Cross, K.P., & Major, C. H. (2005). *Collaborative Learning Techniques: A Handbook for College Faculty*, San Francisco: Jossey-Bass.

Bonney, K. M. (2015, May 16). Case Study Teaching Method Improves Student Performance and Perceptions of Learning Gains. *Journal of Microbiology Biology Education*, 21-28. Retrieved December 26, 2017 <https://www.ncbi.nlm.nih.gov/pmc/articles/PMC4416499/>

Bridgman, T. (2010). Beyond the Manager’s Moral Dilemma: Rethinking the ‘Ideal-Type’ Business Ethics Case. *Journal of Business Ethics*, 94(Supp 2), pp. 311-322.

The Case Centre. (n.d.). *Case Competitions: Student Case Competitions*. Retrieved March 12, 2018 from <https://www.thecasecentre.org/students/learning/competitions/list>

Christensen, C. R. (1991). *Teaching By the Case Method*. Boston MA: Harvard Business School.

Circosta, M. (2013). Why Every Student Should Participate In Case Competitions. *Talent Egg*, Retrieved December 26, 2017 from ,

Clark, J., & White, G. (2010). Experiential Learning: A Definitive Edge in the Job Market. *American Journal of Business Education*, 3(2), 115-118.

Foster, P., & Carboni, I. 2009. Using Student-Centered Cases in the Classroom: An Action Inquiry Approach to Leadership Development. *Journal of Management Education*, vol. 33, no. 6. Retrieved November 30, 2018 from <http://jme.sagepub.com/content/33/6/676>

Levit, A. (2015, March 28). Make Way for Generation Z. *The New York Times*. Retrieved November 28, 2018 from <https://www.nytimes.com/2015/03/29/jobs/make-way-for-generation-z.html>.

Loo, R. (2002). A Meta-Analytic Examination of Kolb's Learning Style Preferences Among Business Majors. *Journal of Education for Business*, 77(5), 252-256.

Marinelli, D., & Pausch, R. (2004). Edutainment for the College Classroom. *The Chronicle of Higher Education*, 50(28), p. B.16.

McCarthy, P.R., & McCarthy, H. M. (2006). When Case Studies Are Not Enough: Integrating Experiential Learning Into Business Curricula. *Journal of Education for Business*, 81(4), 201-204.

Rapeepisarn, K., Wong, K.W., Fung, C.C., & Depickere, A. (2006). Similarities and Differences Between 'Learning Through Play' and Edutainment. *Proceedings of the 3<sup>rd</sup> Australasian Conference on Interactive Entertainment*, pp. 4-6. Retrieved November 28, 2018 from <http://www.reseachrepository.murdoch.edu.au>

Ross, S.D. (2015). *Why Participating in Case Competitions Can Be Valuable for Your Job or Internship Search*. Retrieved December 26, 2017 from <https://ulife.vpul.upeen.edu/careerservices/blog2015/11/09/why-participating-in-case-competitions-can-be-valuable-for-your-job-or-internship-search/>

Schweitzer, K. (2018). *Business Case Competition: Purpose, Types and Rules*. Retrieved October 30, 2018 from <https://thoughtco.com/business-case-competitions-purpose-types-and-rules-466316>

Williams, A. (2015, September 19). Move Over Millennials, Here Comes Generation Z. *New York Times*. Retrieved November 28, 2018 from <https://www.nytimes.com/2015/09/20/fashion/move-over-millennials-here-comes-generation-z.html>

Yeaple, R. (2012, July 9). Is the MBA Case Method Passé? *Forbes*. Retrieved November 28, 2018 from <https://www.forbes.com/sites/ronaldyeaple/2012/07/09/is-the-mba-case-method-passe/>

**IS, IT, Blockchain  
Technology, and Social  
Media - Abstracts**

# A TAXONOMY OF METRICS FOR CLOUD-BASED MICROSERVICES

---

Regular Session

---

***Dr . Jordan Shropshire <sup>1</sup>, Mr . Naveen Pendli <sup>1</sup>***

*1. University of South Alabama*

Corporate system architecture is evolving. The back end of most consumer-based apps and tools no longer consists of one program, but many interconnected programs called microservices. A microservice is a unit of application which contributes a specific, narrowly defined function to the greater system. Each microservice is designed, built, and managed independently. This is a significant departure from previous architectures. However, it is still necessary for companies to monitor the workload and performance of their cloud-based services. They also need to forecast growth, make disaster recovery plans, and ensure the availability of their systems across a number of scenarios. Hence, this research identifies metrics for assessing microservices. The metrics are sorted by function and incorporated into a taxonomy. Organizations can be assured of proper coverage by selecting metrics from the various categories. Implications for research and practice are also provided.

# Assessing the dynamic capabilities and diffusion process of cloud computing on firm performance

---

Regular Session

---

*Ms . Siyi Dong <sup>1</sup>, Prof . Yuan Liu <sup>1</sup>, Dr . June Wei <sup>2</sup>*

*1. Zhejiang University , 2. University of West Florida*

The paper aims at developing the dynamic capabilities of cloud computing that impact firm performance via different diffusion process. Specifically, first, drawing on the unique cloud computing characteristics and the innovation diffusion theory, this paper identifies different resources that collectively describe the high-order dynamic capabilities of cloud computing. Based on the dynamic capabilities view, two levels of the organization process (inter- and intra- organization process) are investigated as mediators to see the effects of dynamic capabilities on firm performance at a process level. Then, the research model developed in this paper was empirically investigated by using the structural equation model to analyze data collected from 513 firms. The results show that dynamic capabilities of cloud computing have significantly positive impacts on two organization processes. Moreover, cloud computing diffusion into the inter- and intra- organization processes also have positive impacts on firm performance. Finally, this study theoretically contributes to the current literature by: (1) identifying the different sources of dynamic capabilities and conceptualizing the constructs to measure the dynamic capabilities of cloud computing; (2) applying the dynamic capabilities view and innovation diffusion theory to link the dynamic capabilities of cloud computing to firm performance and reveal the different effects across two diffusion processes. Practical implications are also presented for cloud service providers and managers in firms for better understandings of dynamic capabilities given by cloud computing; and the relationships between dynamic capabilities and firm performance in the cloud context.

# Blockchain on the Farm: A Systematic Literature Review

---

Regular Session

---

***Dr . Joseph Kasten*** <sup>1</sup>

*1. The Pennsylvania State University, York Campus*

The safety, availability, and cost of a nation's food supply is of vital importance to its citizens and government. Over time, the use of various technologies has made vast improvements in all aspects of food production and information technology is just the latest. One type of technology with the potential to cause widespread change in the food production process is blockchain. This paper provides a systematic review of the academic literature surrounding the application of blockchain to the production, transport, and protection of food. This review also includes some recommendations for future research directions and provides a strong foundation for further research in the application of blockchain to the agriculture industry.



# Blockchain: A Distributed Ledger Technology

---

Workshop

---

***Dr . Hao Zhang***<sup>1</sup>

*1. James Madison University*

Blockchain and distributed-ledger technologies (DLT) create a new management mode of communication, synchronization, and transfer of value in network systems. World Economic Forum has noted blockchain as one of the top five disruptive technologies and suggests that tipping point for the technology would happen by 2027. Although it gained prominent attention, blockchain has also created concerns and questions on data security and applicability. Answering those questions will require a thorough understanding of how the technology works and then a discerning eye toward how and where to use it.

This session aims to provide an in-depth understanding of blockchain and DLT from both technical and business perspectives, understand its uncertainties and security, and explore business and industrial applications. The session consists of three topics, a background introduction on DLT and blockchain, a deep dive into the blockchain mechanism to understand how hashing, mining, and proof of work functions in the network system, and a discussion on existing and potential applications in business and industry. In addition to engaged activities and discussions, a research example of using blockchain in textile life cycle supply chain sustainability management will also be presented. The targeted audience of this session are business professionals, academic faculty, and students who seek to gain a deeper understanding of blockchain and pursue creative ideas around this technology.

## Defection in Group Buying: A Winning Strategy?

---

Regular Session

---

***Dr . Alexander Pelaez**<sup>1</sup>, **Dr . Elaine Winston**<sup>1</sup>, **Dr . Jim Samuel**<sup>2</sup>*

*1. Hofstra University , 2. University of Charleston*

The objective of this research is to introduce, explore and analyze defection in a collective buying market. We study the effect of defection on buyers in terms of buyer surplus, i.e. profit, and time to completion, i.e. faster time to complete a successful bid, using a quasi-experimental electronic market to uncover the effect of defection, controlling for communication. This experiment enables two research questions in the context of group performance. First, will allow buyers to defect from a group buying scenario breakdown efforts by the group to form successful bids and thus hinder the performance of the group? Second, will buyers, who defect, either occasionally or consistently, be able to generate more profit away from the group? Finally, how will other buyers respond or perform in the presence of defection? In addition, to the core data collected, we will collect demographic information, in order to control for the demographic effects. Using standard methods of experimental economics, we implement a simple group buying platform in the lab and conducted a repeated-measure controlled experiment controlling for the defection manipulation on group performance.

# Designing and implementing a design studio for the Internet of Things: A 3-year retrospective

---

Regular Session

---

***Dr . Christopher Starr*** <sup>1</sup>

*1. College of Charleston*

Makerspaces, which are facilities with digital devices for product prototyping such as 3D printers, 2D and 3D cutters and injection molding machines, are now common in colleges and universities. Makerspaces can be found in centralized locations such as campus libraries or distributed in one or more specific academic units. Newer to university campuses are IoT facilities for student and faculty development of digitally enabled products that combine traditional makerspace tools for product prototyping and production with and digital sensors, computers and communication technologies. IoT enables physical things to have an internet presence, or digital twin, to create new value propositions for solution building. More recent advances in standards, security and cloud support for IoT, position IoT devices as distributed sensors for centralized decision support, to decision points driven by locally sensed data as edge computing devices.

Concomitant to the advent of the IoT makerspace is the increase in interface abstractions provided by vendor and open source tooling, decreasing the barriers to entry for undergraduate students across majors. The increase in accessibility makes IoT makerspaces accessible to business and liberal arts students without the prerequisite of a background in engineering or programming.

This paper describes how the makerspace at one liberal arts university reimagined and retooled a traditional makerspace to launch an IoT design studio. Quantitative outcomes are presented include the tooling decisions, budget, organizational framework, training, safety and utility across three years of running an IoT studio in a school of business. Examples of student products will also be presented.

Keywords: makerspace, Internet of Things, experiential learning, interdisciplinary, innovation, information systems

# Determinants of Social Networking Website Loyalty: An Empirical Test of a Causal Model

---

Regular Session

---

*Dr . Kenny Jih* <sup>1</sup>

*1. Middle Tennessee State University*

The popularity of social networking websites has prompted researchers in various disciplines to examine their social and organizational impacts from different points of view, both as the target and as the instrument of the study. This study used Facebook, a leading social networking platform, as the target of inquiry to explore the direct and indirect factors affecting user loyalty to the social networking website. Drawing from the existing research literature, we identified four factors that might play significant roles in user adoption of the website. Specifically, our study assessed how enjoyment directly affected social presence, enjoyment, perceived privacy risk, self-disclosure, and website. We also investigated the indirect impacts of social presence, perceived privacy risk and self-disclosure to establish a chain of effects. An online questionnaire survey was conducted to collect responses from Facebook users in Taiwan using a web-enabled survey platform My3Q. After assessing the appropriateness of research data with Common Method Variance analysis, reliability analysis, and validity analysis, we analyzed the cause-effect relationships between the research constructs using a structural equations modeling software AMOS. The analyses validated four aspects of the theoretical model: (1) the positive direct effect of enjoyment on social presence as well as website loyalty, and indirect effect of enjoyment on perceived privacy risk and self-disclosure through social presence, (2) the negative impact of social presence on perceived privacy risk and positive impact of social presence on self-disclosure, (3) the negative impact of perceived privacy risk on self-disclosure, and (4) positive impact of self-disclosure on website loyalty. The paper concludes with theoretical implications of our findings as well as lessons learned for practicing managers.

# Developing Grit through Self-Actualization: Understanding how Logistical, Communication, and Information Applications Influence the Hierarchy of Needs

---

Regular Session

---

*Dr . Pamela Galluch Schlosser <sup>1</sup>, Dr . Gulfem Kutlu <sup>1</sup>*

*1. Roanoke College*

Since the explosion of smartphones into society, Smartphone Applications, referred to as “Apps,” have flooded the online market. This paper redefines Maslow’s hierarchy of needs and determines where Apps can help facilitate or hinder our ability to meet each need. Specifically, we look at Logistical, Communication, and Information type Apps and see how each type affects our needs. We also investigate which need helps establish Grit, which is the ability to develop a perseverance and passion for satisfying long term goals. After collecting preliminary data through an online survey, we found that many applications do help us meet our needs, in particular Logistic and Information type Apps. We also found that Communication Apps hinder our ability to meet our social needs, suggesting that Social Media type Apps can actually make us feel less included. Finally, we found that Grit can be developed through Self-Actualization.

# Factors Impact Tax Regulation Compliance for Virtual Products from Financial and Economic Perspectives

---

Regular Session

---

*Ms . Hannah Ji <sup>1</sup>, Dr . June Wei <sup>2</sup>*

*1. John Hopkins University , 2. University of West Florida*

This paper aims to investigate the influence factors related to virtual software products that have impacts on tax regulation compliance. It first constructs a research model to analyze the influence factors on the tax regulation compliance of digital goods and services. These factors include independent variables such as seller' location, product type, product price, exchange rate, payment method, and existing international e-commerce taxation regulations that brick-and-mortar commerce engages. The moderation impacts on macro (economy, culture, policy) and micro (age, gender, education level) levels are also analyzed. Second, a set of propositions are developed. Third, to quantitatively measure these influence factors in the research model, eight items were derived and then a survey was created with a total of twenty questions. Finally, the theoretical, managerial and practical implications are also presented.

# Machine Learning and Artificial Intelligence Learning within the Classroom

---

Regular Session

---

***Dr . Jack Crumbly*** <sup>1</sup>

*1. Tuskegee University*

Decision makers within organizations seek to find methods for improving business processes. Currently, most use Enterprise Resource Planning systems to assist in decision making within operations, logistics and procurement. This research is an effort between decision makers within an organization and a university to implement Machine Learning and Artificial Intelligence as an alternative to improving decision making in business process. The research will discuss the learning process of students with Machine Learning and AI tools. Next steps will also be discussed within the research.

# Motivating Knowledge Sharing in Enterprise Social Media: Impact of Avid and Impressionable Learners

---

Regular Session

---

***Dr . Shankar Sundaresan <sup>1</sup>, Dr . Zuopeng (Justin) Zhang <sup>2</sup>***

*1. Rutgers University-Camden , 2. University of North Florida*

This paper studies the use of enterprise social media (ESM) in facilitating knowledge sharing in organizations. Focusing on two types of learners (*avid* or *impressionable*), we explore how they influence the design of reward systems that motivate workers to share knowledge. This research provides valuable insights for practitioners to implement appropriate reward systems to promote knowledge sharing and learning in ESM.



# Problems and Solutions in Teaching Data Communication to Undergraduate Students

---

Regular Session

---

*Dr. John O'Malley*<sup>1</sup>

*1. Georgia Southern University*

Many business and IT programs require students to take at least 1 data communication course. Often the course is taught at the junior level when students are selecting their major. Many of the students do not understand why the data communication course is required and how the course will help them in their future work.

As such teaching an introductory data communication to undergraduate students can be challenging. Some of the challenges include finding a textbook that has the right technical content and level for students, finding lab assignments that are appropriate and match the software that is available, students often have little to no background in data communication, and students not appreciating the value in a data communication course. This session will consist of several faculty who teach data communications at different universities and have found some solutions to the problems listed. The faculty will discuss how they have addressed these problems and how well the solutions have worked. In addition, the faculty will provide information on textbooks and lab assignments for students in IS and IT programs. In addition, the faculty will be open to addressing problems that others have had and will look on ways to improve student appreciation for the data communication field. It is hoped that session attendees will provide their experiences including successes and failures to help everyone improve teaching data communications.

# Technological Challenges of Asian Higher Education Students

---

Regular Session

---

***Dr . W. Stewart Thomas <sup>1</sup>, Dr . John E Spillan <sup>2</sup>***

*1. UNCP, 2. University of North Carolina Pembroke*

Many researchers are aware of the technology challenges of Chinese citizens as well as visitors. Laptops and other electronic devices of visitors are often susceptible to unwarranted attacks often resulting in unauthorized copy of intellectual properties as well as continued unauthorized monitoring once the visitor has returned to his or her home country. With somewhat sophisticated monitoring and intrusion of unwanted Chinese access to devices while in China, many would think technology available to Chinese students would be equally sophisticated. However, Chinese students face technological issues which cause challenges in their post secondary education. This paper examines technological challenges facing Chinese college students as well as their self-accessed level of software use competency and personal opinion of the value of technology in their lives.

# THE IMPACT OF TECHNOLOGY, BIG DATA AND ANALYTICS – THE EVOLVING DATA-DRIVEN MODEL OF INNOVATION IN FINANCE INDUSTRY

---

Regular Session

---

***Dr . Rashmi Malhotra <sup>1</sup>, Dr . Davinder Malhotra <sup>2</sup>***

*1. Saint Joseph's University , 2. Thomas Jefferson University*

*The emergence of a digitally driven way of life in this century is driving the global economy in many ways, thereby forcing all businesses to rethink the way they operate and make decisions. The financial sector is also feeling the impact of these disruptive forces. This study examines different factors that are pressuring the financial institutions to rethink the way they do business. Further, we also present the evolving, data-centric and analytics-drive, business model of the finance sector to survive and compete in today's dynamic and digital global market place.*

# Understanding the Role of Context Variables in Web 2.0 Based Knowledge Management in An Organization

---

Regular Session

---

***Dr . Anupam Nath <sup>1</sup>, Mr . Amit Nath <sup>2</sup>***

*1. School of Business, Georgia Gwinnett College, Lawrenceville, Georgia , 2. Florida State University*

Organizations generate value through Knowledge management (KM) which is the process of generating value from their intellectual and knowledge-based assets. Web 2.0, a set of Internet-based applications that harness network effects by facilitating collaborative and participative computing. Web 2.0 has increased immensely in popularity, availability, and power in the last few years in organizations, especially in the field of Knowledge Management (KM). In our research, we study the role of context variables on the effective adoption of Web 2.0 for KM in Organizations. We adopt an exploratory case study based research approach to understand the role of different KM context variables identified in the existing literature.

# Usability Comparison Study Between E-Commerce and V-Commerce

---

Regular Session

---

*Mr . Nick Jones <sup>1</sup>, Mr . Philip Billings <sup>1</sup>, Dr . June Wei <sup>1</sup>*

*1. University of West Florida*

This paper aims to determine the differences in preference in regards to usability of Electronic Commerce (E-Commerce) and Virtual Commerce (V-Commerce). To assess user preferences on usability, a virtual commerce shopping website was developed first, and then a survey was created with a total of fifteen items to measure. Data was collected by asking subjects to first browse the developed virtual commerce shopping website, and then answer the fourteen-item questionnaire. The major findings from the statistical analysis indicates that there are six usability items of V-Commerce elements that are superior to E-Commerce. Moreover, the results also indicate strong feelings differences by using mobile and stationary devices. Furthermore, users are more likely to accept V-Commerce if implemented properly. Some theoretical, managerial and practical implications are also presented.

# Wielding Blockchain to Enhance Counterfeit Drugs Prevention in Pharmaceutical Industry: A Practitioners' Perspective

---

Regular Session

---

*Dr . John (Chengqi) Guo <sup>1</sup>, Dr . Ping Wang <sup>1</sup>*

*1. James Madison University*

In the eyes of supply chain businesses, blockchain shows signs of future success that brings about transparency, integrity, and durability. These are important qualities of effective supply chain management, especially for entities in the healthcare and pharmaceutical industries. Therefore, this paper aims to (1) provides an in-depth view in terms of leveraging blockchain in pharmaceutical supply chain to create safeguarded and verifiable transactions among stakeholders, allowing them to prevent the entry of counterfeit drugs; (2) proposes the use of UTAUT model to reveal practitioners' perceptions regarding the use intention of the distributed ledger technology. Operational and technical insights are provided to explain how blockchain can recalibrate internal processes within the information flow. Key stakeholders and their roles in the deployment of blockchain solutions are identified and characterized. Limitations, concerns, and remedies are also discussed.

**IS, IT, Blockchain  
Technology, and Social  
Media - Papers**

## A Taxonomy of Metrics for Cloud-Based Microservices

---

### A TAXONOMY OF METRICS FOR CLOUD-BASED MICROSERVICES

Jordan Shropshire, Professor of Information Systems, School of Computing, University of South Alabama, 150 Jaguar Drive, Suite 2101, Mobile, AL 36688, [jshropshire@southalabama.edu](mailto:jshropshire@southalabama.edu)

Naveen Reddy Pendli, PhD Student, School of Computing, University of South Alabama, 150 Jaguar Drive, Suite 2101, Mobile, AL 36688, [Np1821@jagmail.southalabama.edu](mailto:Np1821@jagmail.southalabama.edu)

### ABSTRACT

Corporate system architecture is evolving. The back end of most consumer-based apps and tools no longer consists of one program, but many interconnected programs called microservices. A microservice is a unit of application which contributes a specific, narrowly defined function to the greater system. Each microservice is designed, built, and managed independently. This is a significant departure from previous architectures. However, it is still necessary for companies to monitor the workload and performance of their cloud-based services. They also need to forecast growth, make disaster recovery plans, and ensure the availability of their systems across a number of scenarios. Hence, this research identifies metrics for assessing microservices. The metrics are sorted by function and incorporated into a taxonomy. Organizations can be assured of proper coverage by selecting metrics from the various categories. Implications for research and practice are also provided.

**KEYWORDS:** Microservices, metrics, performance, workload, cloud computing

### INTRODUCTION

Enterprise systems are constantly evolving to integrate advances in system and software design. An emerging design trend in server-side computing is the microservice architecture. A microservice is a unit of software designed to perform a specific function for the system at large [5]. The application exists as a loosely-defined group of microservice units. Each microservice is independently designed, developed, and maintained [10]. Often, the team that builds the microservice is often responsible for maintaining it. This practice is part of DevOps, another recent trend in organizational computing. The benefit of composing an application from microservices is that enforces modularity. This simplifies the design and makes it easier to develop, test, and deploy. Microservices enhance scalability and build resilience. If any particular microservice is strained by demand additional units can be stood up in parallel to accommodate the spike.

Microservices represent a significant departure from earlier, more monolithic designs. They allow for more fine-grained interfaces, provide more resilience, and focus on doing a specific function very well [1]. Monolithic designs, such as enterprise resource planning systems, tend to take the form of a massive, monolithic platform with highly-coupled functions which are tightly integrated into the fabric. Although enterprise planning systems provide significant value, they can be difficult to support. If a single function breaks than the entire system may come to a halt.



## A Taxonomy of Metrics for Cloud-Based Microservices

---

Besides the obvious consequences of service downtime, a failing monolithic application has complex troubleshooting requirements. The troubleshooting requirements for microservices are conceivable more straightforward [4]. Further, the desire for functional independence and resilience is fully realized in microservices.

Between monolithic and microservice platforms there are key differences in design, development, troubleshooting, and performance analysis. An implication of these differences is that each platform requires specific observability metrics [8]. While the tools and measures for monolithic applications have long been in place, there is relatively less formalized guidance on the analysis of microservices [14]. Hence, the purpose of this study is to systematically review the extant material on microservices, identify all the metrics currently in use, and arrange them in a taxonomy of mutually exclusive, exhaustive categories. The resulting structure is intended to be useful for computing professionals and for researchers. It is structured such that selecting metrics from the various categories will provide adequate measurement coverage across the stack. Businesses referring to this taxonomy will have clear insights into the performance of their microservices [16]. Further, it underscores the areas where coverage is adequate and where new, more specific metrics should be developed.

The remainder of this paper is structured as follows: the next section is the literature. It begins by reviewing the concept of microservices in more detail and then it reviews background literature on workload and performance monitoring. The theoretical development section follows. It articulates the taxonomy design goals. Following this section is the methods section. It describes the qualitative research processes which were used to identify the metrics and create the taxonomy. The Resulting taxonomy is increased in more detail in the results section. The following section is the implication section. It provides insights for practice and for researchers. Finally, concluding comments are offered.

### LITERATURE REVIEW

To provide context for the current research a literature review is conducted. First, description of microservices is provided. Next, the importance and implications of monitoring are considered.

#### Microservices

Microservices are small, autonomous services that work well together. They combine to form applications, utilities, and other tools which provide value. Microservices are focused on doing one specific task well. And they are designed to be as small as possible to perform that task. In some senses, microservices are the antithesis of large, modular, monolithic code bases (see Figure 1, below). These large code bases tend to have arbitrary boundaries which are inconsistently maintained. Demarcation of responsibility is difficult to track [1]. It is expensive to trace interdependencies through a monolithic programs. Code related to similar functions starts to appear all over, making it difficult to maintain [2]. Software engineers try to prevent these design flaws by creating abstractions or modules. [5] However, it takes even more design overhead to ensure consist adherence to these rules. Furthermore, patterns, serialized standards, and APIs tend to grow exponentially. This increases the attack surface and needlessly exposes sensitive processes to outside perturbations.

## A Taxonomy of Metrics for Cloud-Based Microservices

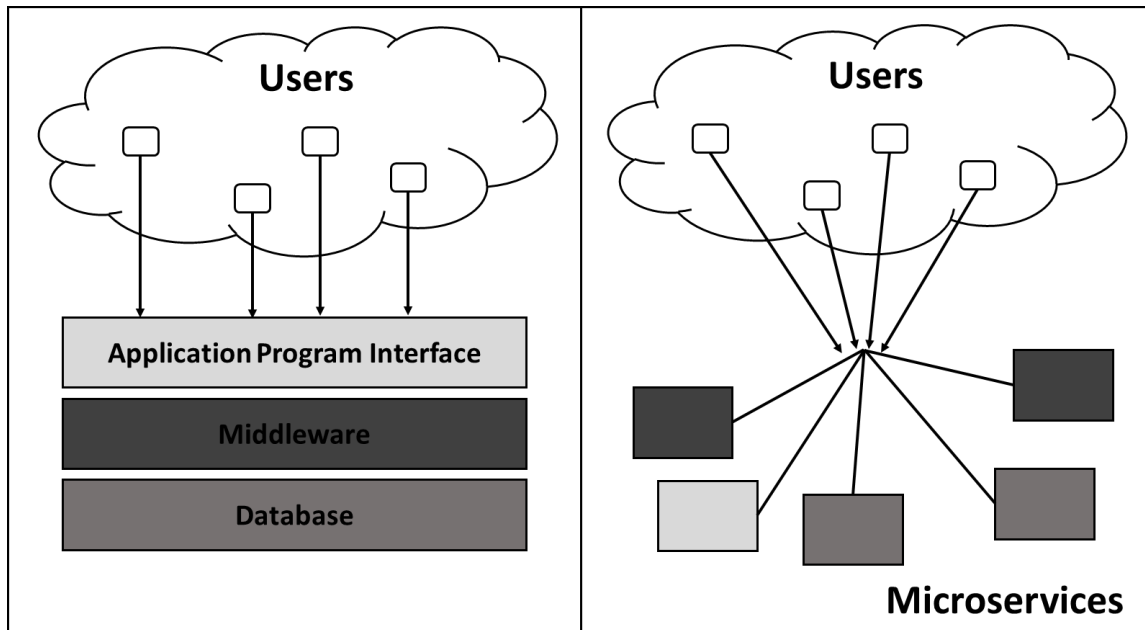

**Figure 1: Monolithic and Microservice Architectures**

Microservices are software components that are specialized in one functional task [6]. They do a simple job. It is often suggested that the key to defining a microservice is to focus on the organizational task being completed instead of units of software. It should be isolated enough that it can be executed without interfering with other parts of the system [8]. This is comparable to the role of an employee's job function. It is an independent function which generates values in and of itself.

The microservice is a separate entity. It can be implemented as an isolated component or it could be part of a platform as a service [10]. It is generally recommended that each microservice should use its own operating system. However, containerized microservices are considered isolated enough that they meet this requirement. Although the requirement for isolation adds overhead it simplifies patching, updating, and maintenance. All of the communications between microservices should be implemented as network calls [12]. A publication/subscription style messenger service is ideal communication solution because it requires a relatively low level of coordination between components [11]. Microservices also require application program interfaces in order to support service requests stemming from customers. This is another benefit of isolation. Each microservice will have a constricted firewall with a short list of open ports.

### Workload and Performance Monitoring

Public cloud computing offers a number of advantages over traditional environments because it doesn't require large fixed costs and expensive upfront investments [3]. Instead, it uses pay-as-you-go pricing models [7]. Cloud customers are charged for exactly how they consume in terms of resources. In order to maximize the benefits of the cloud computing system, it is necessary to

## A Taxonomy of Metrics for Cloud-Based Microservices

---

assess performance and fine-tune resource consumption models [13]. Failure to control resource usage will result in sub-par performance and unnecessarily high costs. Cost control and service level agreements must be optimized in order to ensure happy customers and business profits. Monitoring workloads for clouds introduced a number of complexities early on [15]. Although these pain points have been addressed a number of new issues have surfaced for microservice performance analysis. Microservices are complete, isolated software units. They include everything from operating system, applications, data, and user interfaces [9]. In essence, they are full stack. This means broad swatch of metrics must be observed. Performance at all layers must be analyzed in order to tenure the efficient solution possible [15]. Hence, this research proposes a framework for ensuring complete measurement of a microservice

### THEORETICAL DEVELOPMENT

Based on the differences between the prevailing architectures and the microservice design, it is apparent that new metrics and measures are needed to accurately capture system state. Hence, this research proposes a new taxonomy for cloud-hosted microservices. The proposed taxonomy is designed to maximize the follow attributes:

- **Comprehensiveness:** The taxonomy should completely summarize the field of possible metrics
- **Granularity:** The taxonomy should incorporate metrics which are observed at different levels of analysis
- **Organization:** The metrics should be organized into a series of adjacent categories which collectively represent the spectrum of measurement possibilities.
- **Discretion:** Care should be taken to minimize overlap between categories of metrics

These features will result in a structure which provides utility to researchers seeking to evaluate new microservice architectures and to organizations wishing to test and monitor their production systems.

### METHODS

This section describes the procedure for developing the taxonomy. First, it outlines the method for identifying useful, relevant metrics. Next, it describes the process by which metrics are categorized. Third, it describes the construction of the taxonomy.

#### **Metric Discovery**

This section describes the procedure for identifying useful, relevant metrics. The technique used to derive the pool of metrics is content analysis. Content Analysis is a technique used in the social and behavioral sciences to draw inferences from text [17]. In this case the text includes articles which concern cloud computing, microservice architecture, and/or performance monitoring. Each reference to a metric or a monitoring technique was extracted and transcribed on a master list.

The population of documents consists of all periodical articles and technical guides which involve microservice monitoring. The sample was drawn from the population as follows: Google

## A Taxonomy of Metrics for Cloud-Based Microservices

---

Scholar, Academic Search Premier, and Google were queried using keywords such as “microservice,” “service,” “cloud,” and “monitoring.” Keywords were combined using Boolean search terms in order to achieve more specific result sets. Some 102 articles were initially found. After initial inspection, 31 were culled because the content in the documents was not related to this study. For instance, some articles referenced the term “microservice” but were related to small business financing and staffing. An additional 19 articles did not contain any references to assessment, monitoring, or performance evaluation. This resulted in 52 useable documents. It should be noted that the majority of the articles were published in trade publications, industry-specific magazines, and IT practitioner-oriented journals; few manuscripts came from academic or peer-reviewed sources. Many of the documents were technical manuals written for system implementers.

### **Categorization**

Each instance of a metric was identified and coded using an a priori coding scheme. The coding scheme consists of the general layers in a solution stack: network, hardware, operating system, application, and interface. This scheme was used to categorize each of the metric instances from the first ten articles. After independently coding the first ten articles, the authors compared amendments and extensions to the coding scheme. Problematic portions of the coding scheme were addressed; categories were modified to the extent that they became mutually exclusive and exhaustive. The amended scheme was applied to the remainder of the units. Periodic quality control checks confirmed the enumeration.

### **Taxonomy Construction**

A total of 113 metric instances were identified and coded. The resulting data were organized into a series of 7 microservice metric categories and 34 sub-categories. As with coding, creating a taxonomy is qualitative research technique. Thus, the most rigorous method for defining the categories was used [18]. The technique for creating the categories is based on manual grouping. First, the metrics which are most similar are identified. By similar it is meant that their combination would have the smallest effect on the observed differences in the group as a whole. There were instances of identical metrics. Redundancies were flagged and eliminated. Next, the units were regrouped, taking into account the losses incurred within the newly-formed group. Third, the data were modified to reflect the latest configuration of groups on which the next merger is computed. This procedure was repeated until nothing more could be combined without changing the meaning of the group.

## **RESULTS**

The results of the research resulted in a taxonomy consisting of 5 main categories with a total of 21 areas of measurement. These areas are akin to the layers of a generic compute stacking. Figure 2 (below) provides a high-level overview of the taxonomy. The main taxonomic categories are: networking, API (Application-Program Interface), application, OS, and hardware. The categories include a total 21 types of measurements. It should be noted that more measurements exist. However, the majority of these are similar to a concept already represented in the categories.

## A Taxonomy of Metrics for Cloud-Based Microservices

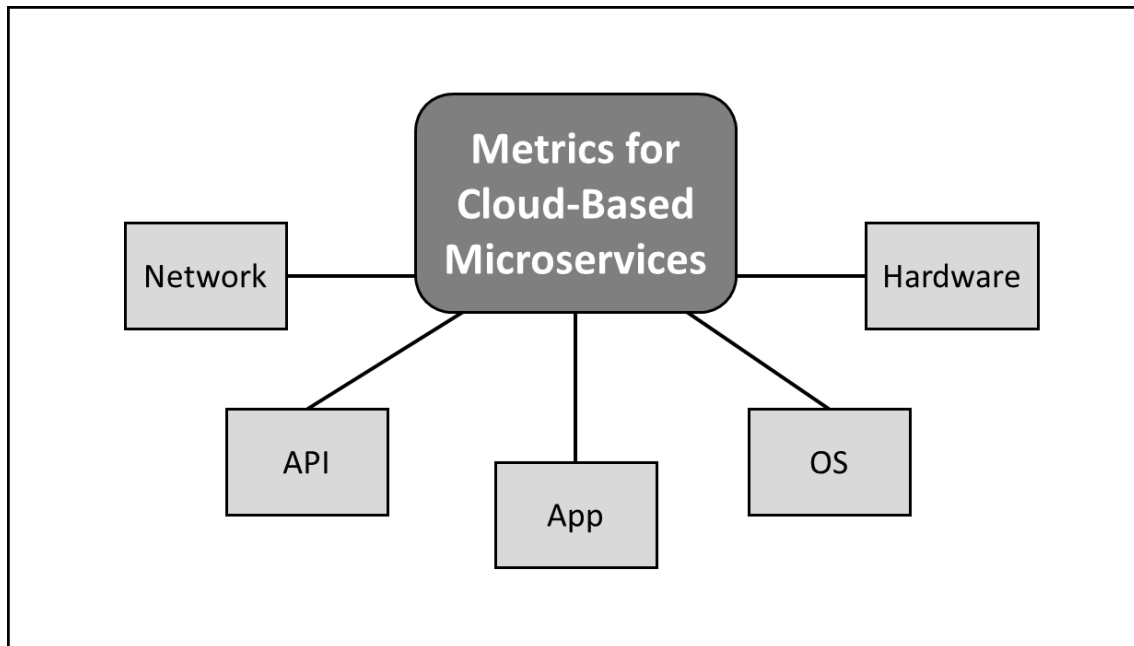

**Figure 2: Taxonomic Structure**

More specifically, Table 1 (below) presents a list of the final metrics and their definitions, sorted by category. The list is not exhaustive in the sense that every possible metric is included in the table. However, it is representative of the kinds of metrics observed at every layer.

Each of the five categories represents a different layer in a complete solution stack. The first layer is the network layer. It includes all the hardware apart from the host server required to establish the connection. The second category is the application program interface (API). This is the portal through which user requests flow. The third category is the application. This includes databases, custom apps, pre-built software, and other utilities for delivering a basic microservice. The fourth category is operating systems. This covers the operating system which supports the applications. Regardless of the applications are deployed as containers, within virtual machines, or natively installed on host servers, there is an operating system associated with the microservice. Finally, the last category includes the hardware. Observing hardware level performance is important because it provides a point of comparison for upper layers in the stack.

A careful analysis will indicate that there are commonalities between the layers. For instance, some form of throughput is measured at each layer. This is the maximum amount of work that can be performed. It could be packets sent or received over the network or SQL queries that can be processed. The layers also have unique measures for success. Success at each layer is different. However, these measures all represent the amount of work that is successfully performed. The layers also need measures for error rate. This is the number of erroneous results in a period of time. It could also be standardized to a ratio. Finally, the layers also include

## A Taxonomy of Metrics for Cloud-Based Microservices

efficiency metrics. These are often called performance metrics because they represent a derivative of latency.

Category	Name	Description / Remark
Network	Bandwidth	This is maximum possible of data transmission. The upper boundary is a physical limitation of the connection media.
	Network Throughput	Measurement of the actual transmission rate. Bandwidth, congestion, and packet loss impact throughput
	Packet Loss	The number or percent of packets that are lost during data transmission over the network. High loss levels may be indicative of hardware problems.
	Latency	The amount of time it takes to send a packet and receive a response. Measures performance
	Retransmission Rate	TCP ensures delivery of packets. When packets are lost or dropped, they must be resent. A measure of error
API	Uptime	This measured using heartbeats, pings, or health statistics to ensure the API is accepting incoming requests
	Requests per Minute	A measurement of the number of incoming service requests that handled over the interface. A measurement of throughput.
	Errors per-minute	Tracks the number of non-200 status codes per minute. Provides insight into the problems that are occurring
	Unique API consumer	Reports the total number of unique customers over a month. Increases in API usage can be attributed to a few large customers or to clients with buggy integrations.
Application	Average response time	The average amount of time it takes to send and receive a response from a predefined query or app request.
	Error Rate	Tracks the percent of failed requests at the application level
	Runtime load	Number of threads association with application
	Application Throughput	Indicates the amount of work the application is doing in unit-time. Important for scalability.
OS	Process / Thread Count	The number of processes or threads currently active
	CPU idle time	Measurement of the amount of time the CPU is busy
	File System IO	Tests latency and throughout of storage operations
	Socket Count	A count of the number of sockets currently consumed by the network stack
Hardware	CPU utilization	Percent of CPU consumed
	Memory Utilization	Percent of memory consumed
	Disk I/O	Rate of read/write to nonvolatile media
	Network I/O	Rate of read/write between network media and an access card

### IMPLICATIONS

The present study has several implications for research. It holds that although platforms and architectures change, the core low-level metrics tend to remain constant. At a micro level, the

## A Taxonomy of Metrics for Cloud-Based Microservices

---

most basic counters have been reused for decades. This is especially true for network and hardware level measures, for which there are few different ways to measure a given attribute (e.g., memory consumption). By contrast the tooling for observing application and API performance has become quite a bit more sophisticated. The measures offer more fine grained observation of system state. A salient implication for practice is the need for new metrics and assessments of overall microservice health. Because a litany of fine grained measures is already available, it would be useful to develop and implement summary measures of system health. Further, it would be useful to researchers and practitioners to co-create new metrics which apply to specific classes of microservices.

### CONCLUSION

The need for system monitoring predates the microservice architecture and cloud computing. Organizations have long relied on outside vendors to host their systems and software. Every major shift in the computing paradigm has necessitated a revisit of the metrics for observing system behavior. From mainframe to microcomputer to client/server to cloud, the need to monitor, measure and control system activity has only grown. The microservice architecture differs from previous designs in a number of respects. This has created a need for updated guidance on monitoring. This research fulfills this need by providing one of the first comprehensive surveys of metrics for cloud-based microservices. The metrics are organized into categories. The categories form a taxonomy which collectively ensures broad observability into all aspect of system state. A liberal selection of metrics from across the taxonomy will ensure businesses achieve their goals for service performance, reliability, and efficiency.

### REFERENCES

- [1] Balalaie, A., Heydarnoori, A., and Jamshidi, P. 2016. "Microservices Architecture Enables DevOps: Migration to a Cloud-Native Architecture," *IEEE Software* (33:3), pp 42-52.
- [2] Bao, L., Wu, C., Xiaoxuan, B., Nana, R., and Mengqing, S. 2019. "Performance Modeling and Workflow Scheduling of Microservice-Based Applications in Clouds," *IEEE Transactions on Parallel and Distributed Systems* (30:9), pp 2114-2129.
- [3] Bowers, K., Juels, A., and Oprea, A. Year. "HAIL: a high availability and integrity layer for clouds," 16th ACM Conference on Computer and Communications Security, Chicago, ILL., 2009, pp. 187-198.
- [4] Dragoni, N., Giallorenzo, S., Lafuente, A., Mazzara, M., Montesi, F., and Mustafin, R. 2017. "Microservices: Yesterday, Today, and Tomorrow," in *Present and Ulterior Software Engineering*, M. M. and M. B. (eds.), Springer: NYC.
- [5] Esposito, C., Castiglione, A., and Choo, K. 2016. "Challenges in Delivering Software in the Cloud as Microservices," *IEEE Cloud Computing* (3:5), pp 10-14.

---

## A Taxonomy of Metrics for Cloud-Based Microservices

---

- [6] Fazio, M., Celesti, A., Ranjan, R., Liu, C., Chen, L., and Villari, M. 2016. "Open issues in scheduling microservices in the cloud," *IEEE Cloud Computing* (3:5), pp 81-88.
- [7] Geiger, D., Seedorf, S., Schulze, T., and Schader, M. Year. "Managing the Crowd: Towards a Taxonomy of Crowdsourcing Processes," 17th Americas Conference on Information Systems, Detroit Michigan, 2011, pp. 1-11.
- [8] Jamshidi, P., Pahl, C., Mendonca, N., Lewis, J., and Tilkov, S. 2018. "Microservices: The Journey So Far and Challenges Ahead," *IEEE Software* (35:3), pp 24-35.
- [9] Lombardi, F., and Di Pietro, R. 2008. "Secure Virtualization for Cloud Computing," *Journal of Network and Computer Applications* (34:4), pp 1113-1122.
- [10] Pahl, C., and Jamshidi, P. 2016. "Microservices: A systematic mapping study," in *International Conference on Cloud Computing and Services Science: Lisbon, Portugal*.
- [11] Rademacher, F., Sachweh, S., and Zündorf, A. 2017. "Differences between Model-Driven Development of Service-Oriented and Microservice Architecture," in *IEEE International Conference on Software Architecture Workshops (ICSAW)*, pp. 38-45.
- [12] Rosati, P., Fox, G., Kenny, D., and Lynn, T. 2017. "Quantifying the Financial Value of Cloud Investments: A Systematic Literature Review," in *Cloud Computing Technology and Science (CloudCom): Hong Kong*.
- [13] Schwartz, L. 2015. "Five Common Misconceptions About Cloud Platforms," in *Forbes*: <http://www.forbes.com/sites/oracle/2015/01/12/five-common-misconceptions-about-cloud-platforms/>.
- [14] Thönes, J. 2015. "Microservices," *IEEE Software* (32:1), pp 116-117.
- [15] Youseff, L., Butrico, M., and Da Silva, D. Year. "Toward a Unified Ontology of Cloud Computing," *Grid Computing Environments Workshop*, Austin, TX, 2008, pp. 1-10.
- [16] Zhang, H., Li, S., Jia, Z., Zhong, C., and Zhang, C. 2019. "Microservice Architecture in Reality: An Industrial Inquiry," in *2019 IEEE International Conference on Software Architecture (ICSA)*: Hamburg, Germany.
- [17] Weber, R. 1985. *Basic Content Analysis*, Beverly Hills, CA: Sage
- [18] Krippendorff, K. 1980. *Content Analysis: An Introduction to Its Methodology*. Newbury Park, CA: Sage.



## **BLOCKCHAIN ON THE FARM: A SYSTEMATIC LITERATURE REVIEW**

**Joseph Kasten Pennsylvania State University, York Campus, 1031 Edgecomb Ave, York,  
PA 17543, 717-718-6775, jzk99@psu.edu**

### **ABSTRACT**

The safety, availability, and cost of a nation's food supply is of vital importance to its citizens and government. Over time, the use of various technologies has made vast improvements in all aspects of food production and information technology is just the latest. One type of technology with the potential to cause widespread change in the food production process is blockchain. This paper provides a systematic review of the academic literature surrounding the application of blockchain to the production, transport, and protection of food. This review also includes some recommendations for future research directions and provides a strong foundation for further research in the application of blockchain to the agriculture industry.

### **INTRODUCTION**

It might never be known if Nakamoto [39] envisioned the use of blockchain (BC) beyond the Bitcoin application introduced in his paper, but the last few years have seen interest in this specific means of data organization and storage extend in a number of other industries far beyond cryptocurrencies. Treblmaier [48] notes its application to supply chains, Sehgal [44] to insurance, and Kasten [26] to engineering and manufacturing. Each of these applications has been described within the last few years and the same can be said for the application of blockchain to agriculture [33].

There are few aspects of civilization more important than its ability to provide food for its citizens. The growing population of the planet, in addition to accelerating changes in the climate, makes this task increasingly difficult and expensive. In this increasingly challenging environment, the use of various technologies has become a vital tool to improve food production, safety, and availability. Information technology has played an important role in improving the quality and availability of food, from Global Positioning Satellites (GPS) directing the harvesting of wheat to the use of the World Wide Web to help farmers find the best price for their produce. This paper examines the research surrounding use of another breakthrough technology, blockchain, in the production and distribution of food.

The value of blockchain in agriculture stems from its ability to secure data such that it can be read by any party with the proper permission but cannot be altered without the knowledge of the other blockchain participants. This is an invaluable property when the sanctity of data must be protected such as in the movement of goods, protecting the provenance of products, and preserving the dates that certain processes (i.e. harvest) take place.

The paper is organized as follows: The next section provides an overview of blockchain technology and extends the discussion as to its application to agricultural processes, the following section describes the methodology followed in the review, the findings of the review

are detailed next, and that is followed by a discussion and conclusion including the limitations of the study and directions for additional research.

## **BLOCKCHAIN OVERVIEW**

Blockchain was introduced as the data-organizing mechanism built into the Bitcoin system of cryptocurrency [39]. The primary benefits of blockchain are that the data contained on the chain formed by blocks of data can be secured if that is appropriate, but more importantly, can be made tamper-proof [16]. This feature of blockchain is derived from the nature of how blocks are added to the chain. When a data block is to be added, the data is first run through a hashing algorithm that applies a cryptographic hash to the data that results in a hash reference value that cannot be reasonably reverse engineered or used to find the original data. These hash references are then combined into another hash reference that includes both the hash from the data to be added, the hash reference from the data preceding the new block, and an unknown variable, which is known as the nonce. In order for the block to be added, the nonce must be found that results in a hash reference that meets certain requirements (e. g. has two zeros as the two leading digits). Because the hash value cannot be reverse engineered to find the nonce, the only method available is to guess and check. These computations require significant computing effort, which can be adjusted by easing the hash reference requirements. This is known as mining in the Bitcoin vernacular.

Once added to the chain, the data on this or any block in the chain cannot be adjusted because of the interconnected nature of the blocks and their joint hash references. If the data on a block that was added to the chain earlier is changed, the hash reference between that block and the next one added must be recomputed as does the hash value for each subsequent block on the chain. Each block added to the chain effectively buries the data below it, making changes to those buried blocks, whether authorized or not, impossible to accomplish without notice by all other stakeholders on the chain.

It is important to note that there are many modifications that can be made to the blockchain architecture that make it more easily implemented, such as storing only the hash reference values on the chain instead of the actual values (known as off-chain storage) or predetermining whether all entities in the business environment can make additions to the chain or only certain entities have this permission (permissionless vs. permissioned blockchain). In the case of off-chain storage, the hash values stored on the blockchain act as immutable “official” values that can be used to check whether the values stored match those in other repositories. These and other options are clearly described by Drescher [16]. Xu et al [53] provide a framework to assist in developing a blockchain-based system that contains the features appropriate to the needs of the organization.

With these capabilities, blockchain-based tools are currently being explored and developed that can provide improvements in a wide variety of agricultural settings. The rest of this paper describes the current state of the literature surrounding these developments.

## METHODOLOGY

In order to perform a systematic literature review, a repeatable and verifiable process must be in place [10]. For the present research, the process used consists of the following steps:

- Identify the research question(s).
- Locate and select relevant studies
- Critically appraise the studies
- Analyze and synthesize the findings
- Disseminate the findings

The research question for this study is “For what aspects of agriculture and food production does research suggest blockchain technology can improve?” Within this research question, two secondary questions are addressed:

- Within the blockchain/agriculture literature, what methodologies are being employed?
- How long has the blockchain/agriculture topic been examined in the academic literature?

To locate the appropriate studies that address these questions, a set of “ground rules” are created to provide structure. For the present study, only the academic literature is examined. This will provide a better picture of the academic effort being expended on this topic. These outlets will include peer-reviewed journals, academic conference proceedings, and chapters from edited volumes. Book length treatments of the topic are also permissible, though the relative recency of the topic combined with its specificity and the dynamism of blockchain development in general render the existence of these books unlikely. Perhaps they will become available after the topic matures. Future studies should also include an examination of the “gray” literature as well as industry periodicals as a means of understanding the business perspective on the use of blockchain in agriculture. At this early point in its development, any reference to blockchain in the practitioner literature is likely to be a general exploration of its possible benefits without exercising any scientific rigor. As with books, maturity in the topic might bring about additional rigor in this arm of the literature.

To be systematic, a review must specify a specific, repeatable methodology. For this study, searches were performed in the ABI/Informs, Emerald, IEEE Explore, JSTOR, Science Direct, and Scopus databases. For each repository, a combination of keywords were used that will provide adequate coverage of the topic. The keywords blockchain, “digital ledger,” “distributed ledger,” and “shared ledger” were combined with agriculture, farm(ing), and food to produce a matrix of 12 search combinations. These searches were conducted in the metadata to include the article title, keywords, and abstract. A full-text search with these keywords, while possible in most databases, would produce a much larger response but with very low precision. Studies were included in the analysis only after they were examined and found to actually focus on the topic at hand. All searching was completed by October 1, 2019.

## FINDINGS

The findings section is divided into two subsections. The first provides descriptive statistics that describe the articles that are included in the study. The second subsection describes the research

themes evident in the body of literature accumulated for this study. Within these themes, a number of sub-themes are described that became evident during the analysis of the literature.

### **Descriptive Statistics**

A total of forty-eight studies are identified using the search protocol outlined above.

- Twelve studies constructed prototypes of varying complexity and performed some form of evaluative process.
- All of the remaining studies were descriptive or prescriptive in nature.

Three research themes emerged from the papers:

- Blockchain applied to improve food supply chain processes (37 papers)
- Blockchain to improve various aspects of the business of food (9 papers)
- Blockchain to improve the actual process of food production (2 papers)

The articles are published in one of two forms:

- journal articles (26)
- conference proceedings (22)

The article location protocol does not specify a time period to search in, however, no papers were found prior to 2016. This is undoubtedly due to the relative immaturity of the blockchain literature in all but the financial services field. However, the number of papers published since then has risen dramatically. Since the papers for this study were accessed before the beginning of the last quarter of 2019, it can be reasonably expected that the number of publications for 2019 will continue to grow, thereby steepening the curve even further. Figure 1 shows the publication trends for the papers included in the study.

### **Research Themes**

During the analysis of the papers included in the study, three primary research themes emerged and are described in this subsection. As might be expected, there is significant overlap in some of these studies such that they might be categorized in multiple themes simultaneously. However, the studies are categorized based on what appears to be the primary focus of the author(s) after reading the abstract, introductory and concluding sections, or in some cases analyzing the entire work. In each case, every effort is made to accurately slot the paper in one of the research themes that emerged during the process.

#### **Research Theme: Food Supply Chain**

The largest theme that emerged from this body of work is that of the use of blockchain to improve and strengthen the supply chain by which food is transported from its place of creation to its place of consumption. Within this theme, there emerge four sub-themes that represent the main thrust of the supply chain mechanisms described in each paper. The most numerous of these is the use of blockchain to improve the supply chain's ability to trace and locate the source of food that is unsafe to consume. This is a particular challenge in an industry that often involves global sourcing and supply routes coupled with an ever-increasing demand for high-quality food,

at an affordable price, that is not grown in the location of its market or during the time when it is in season locally. Some examples of papers with this emphasis include

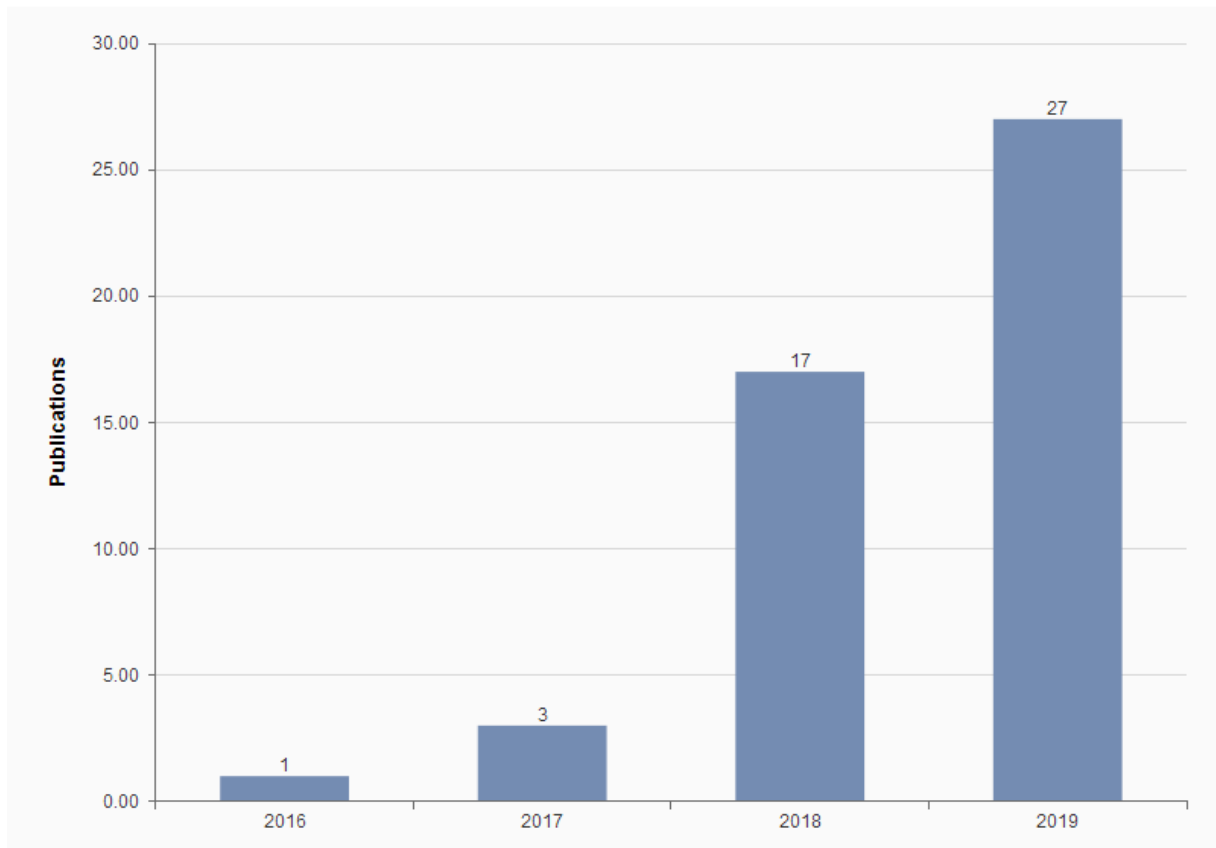

Figure 1: Rate of Publication for Blockchain in Agriculture Papers

Behnke & Janssen's [7] derivation of the boundary conditions that must be in place (i.e. joint supply chain governance and standardization ) before a successful supply chain can be designed and prototype systems that records and tracks the transfer and transformation of food products in the supply chain [20] [21]. The eighteen papers that make up this sub-theme are shown in Table 1. Each paper is described both by its main contribution as well as the authors' approach to the study (descriptive, proposal, prototype).

The second sub-theme contains those studies that focus on the information validity aspects of the supply chain. In these papers, the emphasis is on using blockchain to improve the privacy, accuracy, and validity of the data generated on the chain as well as the information provided to supply chain stakeholders. Many authors chose to concentrate on protecting the provenance of the food materials being produced and transported as a means of protecting the reputation of the food producers or the food producing region from counterfeiters who might seek to profit off of

this reputation by offering substandard goods [3]. Coronado Mondrugaon, Coronado, & Coronado [14] concentrate their efforts on protecting the validity of experimental validation tests of goods that are in production or transportation. The protection of trust between supply chain participants in Europe is protected by the autonomous management of temporal sequences [5]. Table 2 describes the ten papers that were classified in this sub-theme.

<b>Author(s)</b>	<b>Approach</b>	<b>Contribution</b>
Astill et al (2019)	descriptive	Review technologies that enable transparency in supply chains
Behnke & Janssen (2019)	descriptive	Identify conditions necessary for successful Food SC (FSC)
Berti & Semprebon (2018)	descriptive	Examines legal framework surrounding FSC
Creydt & Fischer (2019)	descriptive	Use of BC in FSC
Hayati & Nugraha (2018)	prototype	BC app that tracks food transformations through FSC
Hong et al (2018)	proposal	BC system for tracing food through FSC
Hua et al (2018)	proposal	BC tool to trace food provenance
Kasten (2019b)	proposal	BC system to trace dairy data through FSC
Kshetri (2019)	descriptive	Describes the role of BC in FSC
Lin et al (2019)	prototype	Food safety traceability based on EPCIS
Mondal et al (2019)	prototype	IoT architecture to support FSC transparency
Salah et al (2019)	proposal	BC soybean traceability system
Tian (2017)	proposal	FSC traceability based on HACCP and IoT
Tian (2016)	descriptive	FSC system using RFID
Tse et al (2017)	descriptive	role of BC in the FSC
Wang et al (2019)	proposal	smart contract based traceability in FSC
Yu & Huang (2018)	proposal	trace chicken products using BC and RFID
Zhao et al (2019)	descriptive	review BC literature in FSC

Table 1: Papers Focused on BC in FSC to Improve Food Safety

<b>Author(s)</b>	<b>Approach</b>	<b>Contribution</b>
Arena et al (2019)	proposal	BC system to certify olive oil supply chain
Baralla, Pinna & Corrias (2019)	proposal	BC to allow the traceability of food from production to consumption
Basnayake & Rajapakse (2019)	prototype	BC system to ensure transparency of organic food supply chain
Coronado Mondragon, Coronado & Coronado (2019)	proposal	Protect experimental test data
Ehrenberg & King (2019)	descriptive	Explore the sociotechnical aspects of BC in the FSC
Galvez, Mejuto & Simal-Gandara (2018)	descriptive	Discuss the role of BC to assure authenticity and traceability
Gopi et al (2019)	descriptive	Use of BC to determine provenance and authenticity of seafood
Kim & Laskowski (2018)	descriptive	BC and ontology to protect provenance in the FSC
Malik, Kanhere & Jurdak (2018)	proposal	BC system to provide data transparency and integrity
Scuderi, Foti & Timpanaro (2019)	descriptive	BC to improve transparency and improve fairness for small producers

Table 2: Studies Using Blockchain to Improve Information Validity

Eight authors in this third sub-theme concentrated their blockchain efforts on the improvement of the supply chain's efficiency. With the immutability and traceability built in to the blockchain-based supply chain management system, these authors foresee an increase in asset utilization and a decrease in surpluses and waste. These, in turn, can bring about increased cooperation and the opportunity to access real-time data that can bring about better decisions and reduce transaction costs [1]. Kim et al [29] suggest that the use of a blockchain-based tool can reduce information asymmetry and provide increased transparency to all supply chain participants regardless of size. A more global approach to improving the efficiency of the food supply chain is provided by [25]. Table 3 presents the eight papers in the supply chain efficiency sub-theme.

A fourth sub-theme that emerged within the supply chain theme contains just one paper but addresses a challenge that confronts all sorts of food purveyors: the management of perishable food on the retailer's shelf. An often overlooked, but the only customer-facing, aspect of the food supply chain, it is where the success or failure of all other supply chain links is judged. The customer is the final arbiter of whether the food is fresh and suitable for consumption and making sure that the freshest food available is made can be a very complex process even in a

smaller retailer. The process of shelf management goes well beyond the familiar “rotation” processes carried out by stock clerks the world over. Tsang et al [49] provide a blockchain-based tool that integrates Internet of Things (IoT) and fuzzy logic to provide supply chain data granular enough to support shelf-life decisions.

<b>Author(s)</b>	<b>Approach</b>	<b>Contribution</b>
Amir Latif et al (2019)	descriptive	BC for food retail regulation
Caro et al (2018)	prototype	BC-based traceability tool for FSC
Chandra, Liaqat & Sharma (2019)	prototype	Use of BC to improve the efficiency of the Halal food chain
Kaijun et al (2018)	proposal	Double BC approach to creating comprehensive FSC system
Kamilaris, Fonts & Prenafeta-Boldó (2019)	descriptive	General overview of how BC could improve the efficiency of FSC
Kim et al (2018)	proposal	BC based end-to-end food traceability application
Lai, K. (2018)	descriptive	Describe first actual BC-based FSC transaction
Madumidha et al (2019)	proposal	Overview of BC applications to increase efficiency of FSC

Table 3: Papers that Increase Food Supply Chain Efficiency

### **Research Theme: The Business of Food**

The second theme to emerge from the literature is that of the use of blockchain in the business of food, exclusive of the supply chain. Within this theme, as with the food supply chain literature, a number of sub-themes are included. The largest of these is the management of food-related data within the business of buying, selling, and even donating food. One group of researchers seeks to alleviate the asymmetry of information inherent in the farming industry, especially in less-developed industries and in the credit evaluation process [36] [37]. Nguyen, Das & Tran [40] propose a blockchain-based system to improve farmers’ access to crop failure insurance in Southeast Asia. Lastly, Junfithrana et al [23] develop a system to better manage the process of matching the need for rice to the available stores in Indonesian orphanages. Table 4 lists the six studies in this sub-theme.

Three additional sub-themes emerged, each with only one paper in it. Wu and Tsai [52] propose using dark web technology to ensure the privacy of blockchains and servers used in an agricultural setting. Tao et al [45] suggest the use of blockchain to perform automatic food quality detection. Lastly, Petek and Zajec [41] suggest that new business models centered on the blockchain-based collaboration tools can optimize the connectivity of decentralized communities.



Author(s)	Approach	Contribution
Andreevich, Ivanovich & Ivanovich (2018)	descriptive	Describe possible uses of BC in the agro-industrial complex
Junifithrana et al (2018)	proposal	BC and IoT to manage rice stocks for donation to orphanages
Lin et al (2017)	proposal	BC system to improve record keeping
Mao et al (2018b)	proposal	BC system to improve access to credit for farmers
Mao et al (2018a)	proposal	BC to eliminate information asymmetry in the food trade
Nguyen, Das & Tran (2019)	proposal	BC system to improve access to drought-based insurance

Table 4: Papers Using Blockchain to Improve Data Flow in Agriculture

### Research Theme: Food Production

The actual production of food is the third, and surprisingly small, theme in this study. Only two papers are categorized here. Britt [11] suggests that blockchain will be one of the tools used to develop the dairy herd of the future by streamlining and optimizing the breeding program. Bordel et al [9] propose a blockchain-enabled water control system that will efficiently manage water use among communities in rural areas.

### DISCUSSION

It is clear from the papers reviewed in this study that the literature surrounding the application of blockchain in the agriculture sector has only begun to mature. The literature consists primarily of descriptive and prescriptive studies with very few actual systems being created, even at the prototype level. This is not an unexpected occurrence given that the first agriculture/blockchain study only emerged in 2016. However, the rapid increase in the number of papers being produced hopefully foreshadows that the level of empirical research will begin to increase as well. Of course, for the literature to grow beyond the point of describing what might work to how well it works, there needs to be an increase in the number of blockchain-based applications implemented in industry. While firms such as IBM and SAP have been discussing the usage of blockchain technologies, they are only starting to roll these blockchain tools out to industries such as supply chain, agriculture, and finance ([www.ibm.com/blockchain](http://www.ibm.com/blockchain)). Those that do exist have yet to be studied in any systematic way, but that is exactly what is needed to move the literature to the next level of maturity. Moreover, as more researchers begin to examine these tools as they exist in their various industries, it will likely provide confidence to those firms who have been hesitant to commit resources to the development of blockchain tools, especially if the results of these analyses suggest that the many claims of improved performance, security, and accuracy come to pass.

As the examination of potential and actual blockchain-based tools continues to grow in number, researchers should also begin to consider the shortcomings of blockchain, such as its inability to easily change or delete data from the chain once added. This, and other characteristics, might impose significant changes to organizational processes that utilize this method of data storage and organization. For those applications that require the ability to examine all previously developed data within a process, this aspect of blockchain is very welcome. For others, for whom access to past data is unnecessary or even unwanted, this could prove inconvenient and require that other measures be placed atop the blockchain structure to impose whatever order the firm needs in order to remain compliant with its existing processes.

## CONCLUSION

This paper provides a systematic review of the extant literature on the use of blockchain in the agriculture sector. While it appears that there is a vibrant and growing community of researchers examining the benefits of the blockchain process and proposing new ideas to leverage it to improve operations in many facets of agriculture, there has been little research into the actual results obtained by using blockchain instead of more traditional data storage and security mechanisms. The paper identifies a number of themes evident in the body of literature surveyed and provides examples of research efforts within each one. The study also uncovers some shortcomings in the literature that should be addressed as the blockchain environment begins to mature.

This study has a few limitations that must be noted. To this point, most but not all electronic databases have been examined and only those research efforts that have been peer-reviewed are included. This is not to suggest that the other areas of literature such as that emanating from trade-focused outlets has no worth, only that the focus in this project is to identify research efforts that are undertaken and evaluated in a systematic, verifiable manner. It is left for future research to include other, so-called gray, literature in the review. That will be helpful in developing an understanding of where the industries think blockchain is most valuable and to see if academia's research efforts are aligned with the expectations of the practitioner community.

## REFERENCES

- [1] Amir Latif, R. M., Iqbal, S., Rizwan, O., Shah, S. U. A., Farhan, M., & Ijaz, F. (2019). Blockchain transforms the retail level by using a supply chain rules and regulation. *Proceedings of the 2019 2nd International Conference on Communication, Computing and Digital Systems (C-CODE)*.
- [2] Andreevich, G. K., Ivanovich, E. f., & Ivanovich, M. V. (2018). Prospects for using the blockchain technology in the Aic digital economy. *Proceedings of the 17th International Conference on Machine Learning and Applications*, Orlando, Florida.
- [3] Arena, A., Bianchini, A., Perazzo, P., Vallati, C., & Dini, G. (2019). Bruschetta: an IoT blockchain-based framework for certifying extra virgin olive oil supply chain. *Proceedings of the 2019 IEEE International Conference on Smart Computing (SMARTCOMP)*.

- [4] Astill, J., Dara, R. A., Campbell, M., Farber, J. M., Fraser, E. D. G., Sharif, S., & Yada, R. Y. (2019). Transparency in food supply chains: A review of enabling technology solutions. *Trends in Food Science & Technology*, 91, 240-247. doi:10.1016/tifs.2019.07.024
- [5] Baralla, G., Pina, A., & Corrias, G. (2019). Ensure traceability in European food supply chain by using a blockchain system. *Proceedings of the 2019 IEEE/ACM 2nd International Workshop on Emerging Trends in Software Engineering for Blockchain (WETSEB)*.
- [6] Basnayake, B. M. A. L., & Rajapakse, C. (2019). A blockchain-based decentralized system to ensure the transparency of organic food supply chain. *Proceedings of the Smart Computing and Systems Engineering*, 2019, Sri Lanka.
- [7] Behnke, K., & Janssen, M. F. W. H. A. (2019). Boundary conditions for traceability in food supply chains using blockchain technology. *International Journal of Information Management*. doi:10.1016/j.ijinfomgt.2019.05.025
- [8] Berti, R., & Semprebon, M. (2018). Food traceability in China: Between law and technology. *European Food and Feed Law Review (EFFL)*, 13(6), 522-531.
- [9] Bordel, B., Martin, D., Alcarria, R., & Robles, T. (2019). A blockchain-based water control system for the automatic management of irrigation communities. *Proceedings of the IEEE International Conference on Consumer Electronics (ICCE)*, Madrid, Spain.
- [10] Briner, R. B. & Denyer, D., (2012), Systematic review and evidence synthesis as a practice and scholarship tool. In D. M. Rousseau (Ed.), *The Oxford Handbook of Evidence-Based Management*, Oxford University Press.
- [11] Britt, J. H. (2019). How reproductive management technologies will shape the dairy industry 50 years from now. *Journal of Dairy Science*, 102.
- [12] Caro, M. P., Ali, M. S., Vecchio, M., & Giaffreda, R. (2018). Blockchain-based traceability in agri-food supply chain management: A practical implementation. *Proceedings of the 2018 IoT Vertical and Topical Summit on Agriculture-Tuscany (IOT Tuscany)*, Tuscany, Italy.
- [13] Chandra, G. R., Ali Liaqat, I., & Sharma, B. (2019). Blockchain redefining: The halal food sector. *Proceedings of the 2019 Amity International Conference on Artificial Intelligence (AICAI)*.
- [14] Coronado Mondragon, A. E., Coronado, C. E., & Coronado, E. S. (2019). Investigation the applicability of distributed ledger/blockchain technology in manufacturing and perishable goods supply chains. *Proceedings of the 2019 IEEE 6th International Conference on Industrial Engineering and Applications*.
- [15] Creydt, M., & Fischer, M. (2019). Blockchain and more-Algorithm driven food traceability. *Food Control*, 105, 45-51. doi:10.1016/j.foodcont.2019.05.019

- [16] Drescher, D. (2017). *Blockchain Basics*. New York: Apress.
- [17] Ehrenberg, A. J., & King, J. L. (2019). Blockchain in context. *Information Systems Frontiers*.
- [18] Galvez, J. F., Mejuto, J. C., & Simal-Gandara, J. (2018). Future challenges on the use of blockchain for food traceability analysis. *Trends in Analytical Chemistry*, 107, 222-232. doi:10.1016/j.trac.2018.08.011
- [19] Gopi, K., Mazumder, D., Sammut, J., & Saintilan, N. (2019). Determining the provenance and authenticity of seafood: A review of current methodologies. *Trends in Food Science & Technology*, 91, 294-304. doi:10.1016/tifs.2019.07.010
- [20] Hayati, H., & Nugraha, G. B. B. (2018). Blockchain based traceability system in food supply chain. *Proceedings of the 2018 International Seminar on Research of Information Technology and Intelligent Systems (ISRITIS)*.
- [21] Hong, W., Cai, Y., & Yu, Z. (2018). An agri-product traceability system based on IoT and blockchain technology. *Proceedings of the 2018 1st IEEE International Conference on Hot Information-Centric Networking (Hot ICN 2018)*.
- [22] Hua, J., Wang, X., Kang, M., Wang, H., & Wang, F.-y. (2018). Blockchain based provenance for agricultural products: A distributed platform with duplicated and shared bookkeeping. *Proceedings of the 2018 IEEE Intelligent Vehicles Symposium (IV)*, Changshu, Suzhou, China.
- [23] Junfithrana, A. P., Liani, E., Suwono, M. Z., Meldiana, D., & Suryana, A. (2018). Rice donation system in orphanage based on internet of things, raspberry-pi, and blockchain. *Proceedings of the 2018 4th International Conference on Computing, Engineering, and Design (ICCED)*.
- [24] Kaijun, L., Ya, B., Linbo, J., Han-Chi, F., & Nieuwenjuyse, I. V. (2018). Research on agricultural supply chain system with double chain architecture based on blockchain technology. *Future Generation Computer Systems*, 86, 641-649. doi:10.1016/j.future.2018.04.061
- [25] Kamilaris, A., Fonts, A., & Prenafeta-Boldo, F. X. (2019). The rise of blockchain technology in agriculture and food supply chains. *Trends in Food Science & Technology*, 91, 640-652. doi:10.1016/j.tifs.2019.07.034
- [26] Kasten, J. (2019a), Blockchain application to engineering model management. *Proceedings of the Northeast Decision Sciences Annual Conference*, 362-388.
- [27] Kasten, J. (2019b). Blockchain application: The dairy supply chain. *Journal of Supply Chain Management Systems*, 8(1), 45-54.
- [28] Kim, H. M., & Laskowski, M. (2018). Toward an ontology-driven blockchain design for supply-chain provenance. *Intell Sys Acc Fin Mgmt*, 25, 18-27. doi:10.1002/isaf.1424

- [29] Kim, M., Hilton, B., Burks, Z., & Reyes, J. (2018). Integrating blockchain, smart contract-tokens, and IoT to design a food traceability solution. *Proceedings of the IEEE IEMCON 2018*.
- [30] Kshetri, N. (2019). Blockchain and the economics of food safety. *IT Professional*, 21(3), 63-66. doi:10.1109/MITP.2019.2906761
- [31] Lai, K. (2018). DEAL: first agricultural commodity blockchain transaction. *International Financial Law Review*.
- [32] Lin, Q., Wang, H., Pei, X., & Wang, J. (2019). Food safety traceability system based on blockchain and EPCIS. *IEEE Access Special Section on Smart Caching, Communications, Computing and Cybersecurity For Information-Centric Internet of Things*, 7, 20698-20707. doi:10.1109/ACCESS.2019.2897792
- [33] Lin, Y.-P., Petway, J. R., Anthony, J., Mukhtar, H., Liao, S.-W., Chou, C.-F., & Ho, Y.-F. (2017). Blockchain: The evolutionary next step for ICT e-agriculture. *Environments* 4(50). doi:10.3390/environments4030050
- [34] Madumidha, S., Ranjani, P. S., Varsinee, S. S., & Sundari, P. S. (2019). Transparency and traceability: In food supply chain system using blockchain technology with internet of things. *Proceedings of the Third International Conference on Trends in Electronics and Informatics (ICOEI 2019)*.
- [35] Malik, S., Kanhere, S. S., & Jurdak, R. (2018). *Productchain: Scalable blockchain framework to support provenance in supply chains. Proceedings of the IEEE 17th International Symposium on Network Computing and Applications (NCA)*.
- [36] Mao, D., Hao, Z., Wang, F., & Li, H. (2018a). Innovative blockchain-based approach for sustainable and credible environment in food trade: A case study in Shandong province, China. *Sustainability*. doi:10.3390/su10093149
- [37] Mao, D., Wang, F., Hao, Z., & Li, H. (2018b). Credit evaluation system based on blockchain for multiple stakeholders in the food supply chain. *International Journal of Environmental Research and Public Health*, 15(1627). doi:10.3390/ijerph15081627
- [38] Mondal, S., Wijewardena, K. P., Karuppuswami, S., Kriti, N., Kumar, D., & Chahal, P. (2019). Blockchain inspired RFID-based information architecture for food supply chain. *IEEE Internet of Things Journal*, 6(3), 5803-5813. doi:10.1109/JIOT.2019.2907658
- [39] Nakamoto, S. (2008). Bitcoin: A peer-to-peer electronic cash system. [www.bitcoin.org/bitcoin.pdf](http://www.bitcoin.org/bitcoin.pdf). Accessed 12 July, 2018.
- [40] Nguyen, T. Q., Das, A. K., & Tran, L. T. (2019). NEO smart contract for drought-based insurance. *Proceedings of the IEEE Canadian Conference of Electrical and Computer Engineering (CCECE)*.
-

- [41] Petek, I., & Zajec, N. (2018). Collaborative intelligence and decentralized business community building-potentials in food/nutrition sector. *Proceedings of the 2018 IEEE 34th International Conference on Data Engineering Workshops*.
- [42] Salah, K., Nizamuddin, N., Jayaraman, R., & Omar, M. (2019). Blockchain-based soybean traceability in agricultural supply chain. *IEEE Access*, 7. doi:10.1109/ACCESS.2019.2918000
- [43] Scuderi, A., Foti, V., & Timpanare, G. (2019). The supply chain value of pod and pgi food products through the application of blockchain. *Quality-Access to Success*, 20(S2), 580-587.
- [44] Sehgal, A., (2017), Blockchain's insurance business implementation. *International Journal of Computer Applications*, 174(3), 32.
- [45] Tao, Q., Cui, X., Huang, X., Leigh, A. M., & Gu, A. H. (2019). Food safety supervision system based on hierarchical multi-domain blockchain network. *IEEE Access*, 7, 51817-51826. doi:10.1109/ACCESS.2019.2911265
- [46] Tian, F. (2016). An agri-food supply chain traceability system for China based on RFID & blockchain technology. *Proceedings of the 13th International Conference on Service Systems and Service Management (ICSSSM)*, Kunming, China.
- [47] Tian, F. (2017). A supply chain traceability system for food safety based on HACCP, blockchain & internet of things. *Proceedings of the 2017 International Conference on Service Systems and Service Management*.
- [48] Treblmaier, H., (2018), The impact of the blockchain on the supply chain: A theory-based research framework and a call for action. *Supply Chain Management: An International Journal*, 23(6), 545-559.
- [49] Tsang, Y. P., Choy, K. L., Wu, C. H., Ho, G. T. S. H., & Lam, H. y. (2019). Blockchain-driven IoT for food traceability with an integrated consensus mechanism. *IEEE Access Special Section on Data Mining For Internet of Things*, 7, 129000-129017. doi:10.1109/ACCESS.2019.2940227
- [50] Tse, D., Zhang, B., Yang, Y., Cheng, C., & Mu, H. (2017). Blockchain application in food supply information security. *Proceedings of the IEEE International Conference on Industrial Engineering and Engineering Management*, Singapore.
- [51] Wang, S., Li, D., Zhang, Y., & Chen, J. (2019). Smart contract-based product traceability system in the supply chain scenario. *IEEE Access*, 7, 115122-115133. doi:10.1109/ACCESS.2019.2935873
- [52] Wu, H.-T., & Tsai, C.-W. (2019). An intelligent agriculture network security system based on private blockchains. *Journal of Communications and Networks*. doi:10.1109/JCN.2019.000043

[53] Xu, X., Weber, I., Staples, M., Zhu, L., Bosch, J., Bass, L., ... Rimba, P. (2017). A taxonomy of blockchain-based systems for architecture design. *Proceedings of the 2017 IEEE International Conference on Software Architecture*. DOI: 10.1109/ICSA.2017.33.

[54] Yu, W., & Huang, S. (2018). Traceability of food safety based on block chain and RFID technology. *Proceedings of the 2018 11th International Symposium on Computational Intelligence and Design*.

[55] Zhao, G., Liu, S., Lopez, C., Lu, H., Elgueta, S., Chen, H., & Boshkoska, B. M. (2019). Blockchain technology in agri-food value chain management: A synthesis of applications, challenges and future research directions. *Computers in Industry*, 109, 83-99.

## **Defection in Group Buying: A Winning Strategy?**

*Alexander Pelaez, Hofstra University, Hempstead, NY, 11549, Alexander.Pelaez@hofstra.edu*

*Elaine Winston, Hofstra University, Hempstead, NY, 11549, Elaine.R.Winston@hofstra.edu*

*Jim Samuel, University of Charleston, Charleston, WV, 25304, jimsamuel@ucwv.edu*

### **ABSTRACT**

The objective of this research is to introduce, explore and analyze defection in a collective buying market. We study the effect of defection on buyers in terms of buyer surplus, i.e. profit, and time to completion, i.e. faster time to complete a successful bid, using a quasi-experimental electronic market to uncover the effect of defection, controlling for communication. This experiment enables two research questions in the context of group performance. First, will buyers to defect from a group buying scenario breakdown efforts by the group to form successful bids and thus hinder the performance of the group? Second, will buyers, who defect, either occasionally or consistently, be able to generate more profit away from the group? Finally, how will other buyers respond or perform in the presence of defection? In addition, to the core data collected, we will collect demographic information, in order to control for the demographic effects. Using standard methods of experimental economics, we implement a simple group buying platform in the lab and conducted a repeated-measure controlled experiment controlling for the defection manipulation on group performance.

### **INTRODUCTION**

Electronic markets and online behavior are widely studied by researchers in economics, information systems and marketing. While a number of studies focus on behaviors of the buying process, studies of the social nature of buying are becoming more popular (Liang and Turban, 2012; Kaufmann and Wang 2001). Collective buying enables the study of complex social buying, by examining the study of the interaction of buyers in a collective market. Group buying in a collective market possess many interesting areas of study including, coordination, communication, price effects and strength of ties between buyers. One interesting area of study in collective buying is the effects of defection, i.e buyers who exit groups for their own benefit. This paper focuses on the effects of defection within a group buying market structure, by operationalizing a defection mechanism using an individual level “buy-now” option.

Classical economic theory focuses on the effect of certain drivers of market efficiency, such as price, information exchange and coordination (Hayek, 1945; Galbraith, 1952). Generally, electronic markets are less dependent on coordination between buyers; however, collective buying depends heavily on coordination and collaboration. Buyers in a market coordinate in order to achieve lower prices; however, the study of defection is less studied in these coordinated markets. Defection can cause a decrease of



coordination and cooperation in the market, thus making it more difficult to obtain better prices for buyers. Buyers who defect however, abandon the group market in order to achieve their own benefit.

The objective of this research is to introduce, explore and analyze defection in a collective buying market. We study the effect of defection on buyers in terms of buyer surplus, i.e. profit, and time to completion, i.e. faster time to complete a successful bid, using a quasi-experimental electronic market to uncover the effect of defection, controlling for communication. This experiment enables two research questions in the context of group performance. First, does allowing buyers to defect from a group buying scenario break down efforts by the group to form successful bids and thus hinder performance of the group? Second, will buyers, who defect, either occasionally or consistently, be able to generate more profit away from the group? Finally, how will other buyers respond or perform in the presence of defection? In addition, to the core data collected, we will collect demographic information, in order to control for the demographic effects. Using standard methods of experimental economics, we implement a simple group buying platform in the lab and conducted a repeated-measure controlled experiment controlling for the defection manipulation on group performance.

## LITERATURE REVIEW

### *Collective Buying Markets*

The literature is rich with studies on traditional electronic market characteristics focusing on areas of consumer behavior online, trust in online firms, and risk (Bellman, et al. 1999; Battacherjee, 2002; Gupta et al., 2004). Consumer behavior is an essential component in a group buying environment, since the interaction between each actor is critical to the completion of a successful bid (Tai et al., 2012). The necessary coordination of actors to agree on a bid, acceptable by a seller, is fundamentally different than the one-on-one interaction between a buyer and seller in a traditional e-commerce purchase (Kauffman et al., 2010). One type of group buying auction is a fixed price mechanism, in which the prices are set by the seller based on the number of members in the collective group bid (Kaufmann and Wang, 2001). The second type is a heterogeneous buyer group auction where buyers collaborate on submitting a bid to a seller (Chen et al., 2007). The heterogeneous buyer groups are considered more effective in studying group buying attributes, buyer interdependencies and buyer behavior (Chen et al., 2007).

A review of literature of group buying demonstrates the richness of group-buying for studying economic theory. Studies of group buying have examined customer value in group buying (Lee, et al., 2016), repurchase intention (Hsu, et al. 2014), and social interaction (Lim, 2014). Studies have found the factors such as trust and satisfaction increase intention to participate in group buying, but also examined the effect of psychological traits such as altruism, and reciprocity (Shiau and Chau, 2015). Numerous studies have approached defection from a behavioral perspective examining the role of power status in aiding or abetting defection, defection across auction types, and game theory based mapping of cooperation and defection cycles (Juvina, et. Al., 2012; Hinloopen & Onderstal, 2010; Imhof, et. Al., 2005). Defections

and the influence of exit options have also been studied from a social welfare perspective (Haesevoets, et. al., 2018).

However, to the best of our knowledge, there has been no research conducted specifically examining the effect of defection on group performance in the context of economic experiments. Understanding the role of defection could uncover a number of interesting findings, including the effect of defection on trust and satisfaction, reciprocity, and retribution. Further, by examining the defection, we have a means to study more closely the effect on buyers as a group and individually. A study of defection can yield information regarding bidding behavior in later rounds of the experiment as well as perceptions of the market by the buyers.

### **Defection**

In a group buying auction, cooperation among the buyers is essential (Chen et al., 2009). Communication enhances cooperation in social situations (Kerr and Kaufman-Gilliland, 1994). Previous studies have shown that enhanced communication is not necessary for successful transaction, i.e. increased buyer profit and faster time to completion (Pelaez et al., 2013). Other research has shown that web based coordination platforms enhanced collective effort in buying (Zwass, 2010). Group-buying auctions foster an interdependent environment since a number of buyers must commit to a purchase and are bound together by the collective price. This interdependence is characterized by a high degree of mutuality where no single buyer has more influence over the group (Rusbult and Van Lange, 2002). However, this interdependence is predicated by the necessity that buyers have no other motives other than to maximize their profit (Rusbult and van Lange, 2002).

A condition may exist where a buyer believes profit will be maximized by exiting the group. This situation represents a defection from the group. Defection represents a social dilemma condition in which a buyer acts in a non-cooperative manner (McCarter and Norcraft, 2007). Traditionally, group buying scenarios have no obvious means for defection, however some auction sites such as EBay have the ability to conclude an auction by the use of a “Buy Now” button. This opportunity for a buyer to purchase outside of the group buying framework immediately serves as the mechanism for defection. Defection can lead to a number of consequences including a lack of trust and fear in the group ( McCarter and Norcraft, 2007). The consequences of defection therefore, can lead to lack of group formation (Wang et al., 2016), ostracism of a buyer (Hirshleifer and Rasmusen, 1989), and retribution (Walker, 1999). Ultimately, these issues can lead to lower profits for the group, as well as slower time to task completion.

Though the term defection has been used in broader contexts of non-fulfillment of contracts, disappearance from online commitments, non-delivery of expectations, we limit our use of “defection” to refer to individuals exiting group-buying arrangements in favor of expectation of personal gain (Matsubara & Yokoo, 2002). Defection can be profitable or unprofitable, and defection behavior can be encouraged by allowing incentives and discouraged using penalties for defection (Hinloopen & Onderstal, 2009). While it may be relevant to discourage defection using penalties, reporting mechanisms and debarment from future participation, defectors are sometimes considered to have minimal impact and such “peripheral players” are tactfully ignored (Goyal, 2011).

## RESEARCH QUESTION

We aim to add to the literature of electronic markets by understanding group effects and buyer behaviors under the defection condition. There are two measures of performance that can be explored in an auction, buyer profit and time to task completion. In group-buying electronic markets, buyers benefit from lower prices through the aggregation of purchases (Anand and Aron, 2003). However, defection clearly affects the aggregation coordination, and thus should hinder the group's performance. Thus, our first research question:

*RQ1: Does the inclusion of a defection mechanism impact the performance of buyers in the group?*

Based on RQ1 we propose the following hypothesis:

**H1:** The inclusion of a defection control will have a negative impact on average time to task completion

**H2:** The inclusion of a defection control will have a negative impact on average buyer profit

Our review of the literature highlighted the effects of defection in social scenarios. The non-cooperative behavior can have a number of effects on the group and individual buyer. The economic impacts on the defector and those did not defect are interesting. Further, it is interesting to explore how the group responds to defection as well as how the defector responds to the group. Therefore, our second research question:

*RQ2: How does defection impact the defector and how do buyers in the group respond to defectors?*

Based on RQ2 we propose the following hypotheses

**H3:** The inclusion of a defection control will decrease the number of successful bids

**H4:** The inclusion of a defection control will have a negative impact on defectors buyer surplus, due to the actions of group members.

## METHODOLOGY

We create an economic experiment for an electronic social buying market, using a specific variant of the buyer initiated intra-auction group buying model (Chen et al., 2009). In the experiment participants coordinate group purchases of a single product from a single automated seller. The experiment is designed using the oTree software (Chen et al., 2016). The interface designed in oTree will be similar to a previously implemented version designed in zTree (Fishbacher, 2007). Each buyer in the market is provided with random unique willingness to pay (WTP) value, representing heterogeneous demand preferences. All buyers are put into a single market, and are asked to form by joining bids, or creating bids. Participants will be recruited from a university in the Mid-Atlantic region of the United States.

Each participant recruited will be compensated with a performance payout, which increases external validity by inducing participants to be more engaged in the game, in accordance with induced value theory (Smith, 1976). While the compensation may vary based on performance, each participant is guaranteed \$5 to participate. Payout performance will be determined after a few pilot runs of the simulation to ensure a meaningful and fair payout as well as to manage a budget.

The manipulation conducted in these sessions will be the inclusion of a defection mechanism, representing a 1x2 factorial design. An additional manipulation of group size will be considered after initial pilot runs.

### **Procedure**

Participants are brought into the experiment in groups of 5. The study provides an element of competitive arousal by limiting the actual group bid formation to 3 people, i.e. 3 people exactly will be allowed to submit a bid to the seller, which is automated. Some groups will have the manipulation in which the defection mechanism, operationalized by a “buy now” button will be available to individuals within the group.

The automated seller will select a random number from a uniform distribution (50, 75). This value represents the amount at which the automated seller is willing to accept a group bid price ( $S_g$ ). The seller will also choose an additional value higher than selected group bid price, this will come from a uniform distribution ( $S_g, 100$ ). This ensures that the “Buy Now” option is higher than group bid price. This should minimize the benefit of defection, but only if the groups fail to coordinate.

When 3 buyers form a bid, the bid is sent to the seller, which is then either accepted or rejected, if it matches or is above the “acceptable selling price”. If the bid price is below the “acceptable selling price”, the automated seller waits a random time (1-10 seconds) before rejecting the bid.

Buyers can create bids or join existing bids. Bids are not sent to the seller until the minimum number of buyers, three, have joined the bid group. If the offer is rejected by the seller, the buyers are notified and the buyers once again must regroup and create a new bid. The process continues until the seller accepts the bid or the round terminates after a set amount of time 210 seconds. If during the process a buyer offers to “buy now”, then that buyer will earn the surplus from the purchase, and the round will terminate for all other buyers.

The experiment for each buying group consists of one training/ pilot round to ensure the participants know the rules of the game and allow them to become familiar with the interface. Once the pilot round is complete, the game consists of 10 rounds, each round lasts 210 seconds, or terminates when a bid is accepted by a seller, either the group bid or “buy now” offer. Below in Figure 1 we show an example of the primary buyer screen.

## Market

Buyer Screen				
Last Offer Rejected				
Open Offers				
In	Price	People Joined	People Needed	You Save
No	20	2	1	30
Yes	19	1	2	31
Rejected Offers				
In	Price	Savings		
No	19	32		
Your Limit	You Save	Your Last Bid	Your Bid	
27	27	27	<input style="width: 50px; height: 20px;" type="text"/> <input style="background-color: #0056b3; color: white; padding: 2px 5px;" type="button" value="Submit Bid"/>	
Cumulative Profit: \$39				

Time Left: 3:09

Buy Now

36

Figure 1: View of the Buyer Screen in oTree.

### DISCUSSION

This research provides avenues for future research on defection and models for mitigating defection. It would also be interesting to study defection behavior in an open auction format, where the final price is not only unknown, but is a competitively determined value based on demand by multiple groups, with many of them having the Buy Now option for their users. Furthermore, it would be useful to analyze if the Buy Now option, without any formal penalties, would discourage players from joining groups to start with. Additional thought may be required to address the issue of time-value to players. In the real world, a buy-now defection mechanism would have two attractions to potential defectors - first, the value of time saved by buy-now, and second, the motivation to buy because of the possibility that the final price may be above the buy-now price. The value of time and information are thus crucial drivers of defection behavior and additional research can serve to provide expanded insights.

### CONCLUSION

Previous experiments in group buying have helped validate economic theories. By using a group buying experiment, studies (Pelaez et al., 2013) have shown the effect of price and communication on buyer surplus juxtaposing two different theories: the Hayek Hypothesis (Hayek, 1945), and Countervailing Power theory (Galbraith, 1952). This experiment seeks to contribute to the literature by designing an economic experiment specifically focused on defection, thus providing an opportunity to leverage some insights from game theory, such as the Prisoner’s Dilemma and the Assurance Game.

Specifically, we aim to explore the effects on buyer surplus. It is believed that with the inclusion of defection, buyers will choose the defection option to maximize their own profit under the condition that they are unable to do so with the group. Buyers who choose to execute this strategy early should have the effect of causing the other buyers to react to defectors by not including them in bids or trying to lock them out of bidding. In addition, we believe that group size may play a role in limiting defection.

Finally, examining post experiment survey data, we hope to determine the attitudes toward the market and toward each other. We hope to identify causes of defection in the market and seek ways to predict when a defection will occur. Using this information, it is believed that we will have a strong contribution to the literature on group buying electronic markets.

## REFERENCES

- Anand, K.S., and R. Aron, "Group buying on the Web: A comparison of price-discovery mechanisms," *Management Science*, 2003, 49(11), pp. 15-46.
- Bhattacharjee, A. (2002). Individual trust in online firms: Scale development and initial test. *Journal of Management Information Systems*, 19(1), 211.
- Bellman, S., & Lohse, G. L. and Johnson, E. J. (1999). Predictors of online buying behavior. *Communications of the ACM*, 42(12), 32.
- Chen, J., Chen, X., Kauffman, R. J., & Song, X. (2009). Should we collude? Analyzing the benefits of bidder cooperation in online group-buying auctions. *Electronic Commerce Research and Applications*, 8(4), 191-202.
- Chen, J., Chen, X., & Song, X. (2007). Comparison of the group-buying auction and the fixed pricing mechanism. *Decision Support Systems*, 43, 445-459.
- Chen, D. L., Schonger, M., & Wickens, C. (2016). oTree—An open-source platform for laboratory, online, and field experiments. *Journal of Behavioral and Experimental Finance*, 9, 88-97.
- Fischbacher, U. Z-tree: Zurich toolbox for ready-made economic experiments, *experimental economics* *Experimental Economics*, 2007, 10(2), pp. 171
- Galbraith, J. K. (1952). *American Capitalism: The Concept of Countervailing Power*. Boston: Houghton Mifflin Co, 76.
- Goyal, S. (2011). Learning in networks. In *Handbook of Social Economics* (Vol. 1, pp. 679-727). North-Holland.
- Gupta, A., Su, B. C., & Walter, Z. (2004). Risk profile and consumer shopping behavior in electronic and traditional channels. *Decision Support Systems*, 38(3), 347-367.
- Haesevoets, T., Bostyn, D. H., Reinders Folmer, C., Roets, A., & Van Hiel, A. (2019). Decision making in the prisoner's dilemma game: The effect of exit on cooperation and social welfare. *Journal of Behavioral Decision Making*, 32(1), 61-78.

- Hayek, F. A. (1945). The use of knowledge in society. *The American economic review*, 519-530.
- Hinloopen, J., & Onderstal, A. M. (2009). Going Once, Going Twice, Reported! Cartel Activity and the Effectiveness of Leniency Programs in Experimental Auctions. Tinbergen Institute.
- Hinloopen, J., & Onderstal, S. (2010). Collusion and the choice of auction: An experimental study.
- Hirshleifer, D., & Rasmusen, E. (1989). Cooperation in a repeated prisoners' dilemma with ostracism. *Journal of Economic Behavior & Organization*, 12(1), 87-106.
- Hsu, M. H., Chang, C. M., Chu, K. K., & Lee, Y. J. (2014). Determinants of repurchase intention in online group-buying: The perspectives of DeLone & McLean IS success model and trust. *Computers in Human Behavior*, 36, 234-245.
- Imhof, L. A., Fudenberg, D., & Nowak, M. A. (2005). Evolutionary cycles of cooperation and defection. *Proceedings of the National Academy of Sciences*, 102(31), 10797-10800.
- Jovina, I., Lebiere, C., Gonzalez, C., & Saleem, M. (2012, April). Intergroup prisoner's dilemma with intragroup power dynamics and individual power drive. In *International Conference on Social Computing, Behavioral-Cultural Modeling, and Prediction* (pp. 290-297). Springer, Berlin, Heidelberg.
- Kauffman, R. J., Lai, H., & Lin, H. C. (2010). Consumer adoption of group-buying auctions: an experimental study. *Information Technology and Management*, 11(4), 191-211.
- Kauffman, R. J., & Wang, B. (2001). New buyers' arrival under dynamic pricing market microstructure: The case of group-buying discounts on the Internet. *Journal of Management Information Systems*, 18(2), 157-188.
- Kerr, N. L., & Kaufman-Gilliland, C. M. (1994). Communication, commitment, and cooperation in social dilemma. *Journal of personality and social psychology*, 66(3), 513.
- Lee, Y. K., Lee, Y. K., Kim, S. Y., Kim, S. Y., Chung, N., Chung, N., ... & Lee, J. W. (2016). When social media met commerce: a model of perceived customer value in group-buying. *Journal of Services Marketing*, 30(4), 398-410.
- Liang, T.-P. and Turban, E.. Introduction to the special issue: Social commerce: A research framework for social commerce. *International Journal of Electronic Commerce*, 16, 2 (2012), 5-13.
- Lim, W. M. (2014). Sense of virtual community and perceived critical mass in online group buying. *Journal of Strategic Marketing*, 22(3), 268-283.
- Matsubara, S., & Yokoo, M. (2002). Defection-free exchange mechanisms based on an entry fee imposition. *Artificial Intelligence*, 142(2), 265-286.
- McCarter, M. W., & Northcraft, G. B. (2007). Happy together?: Insights and implications of viewing managed supply chains as a social dilemma. *Journal of operations management*, 25(2), 498-511.

Pelaez, A., Yu, M. Y., & Lang, K. R. (2013). Social buying: the effects of group size and communication on buyer performance. *International Journal of Electronic Commerce*, 18(2), 127-157.

Rusbult, C., and P. Van Lange, "Interaction, interdependence and relationships," *Annual Review of Psychology*, 2002, 54, pp.351.

Smith, V. L. (1976). Experimental economics: Induced value theory. *American Economic Review*, 66(2), 274.

Shiau, W., & Chau, P. Y. K. (2015). Does altruism matter on online group buying? Perspectives from egotistic and altruistic motivation. *Information Technology & People*, 28(3), 677-698.

Tai, C. L., Hong, J. Y., Chang, C. M., & Chen, L. C. (2012). Determinants of consumer's intention to participate in group buying. *Procedia-Social and Behavioral Sciences*, 57, 396-403.

Walker, N. (1999). Even more varieties of retribution. *Philosophy*, 74(4), 595-605.

Wang, W. T., Wang, Y. S., & Liu, E. R. (2016). The stickiness intention of group-buying websites: The integration of the commitment-trust theory and e-commerce success model. *Information & Management*, 53(5), 625-642.

Zwass, V. (2010) Co-Creation: Toward a Taxonomy and an Integrated Research Perspective, *International Journal of Electronic Commerce*, 15, 1 (2010), 11-48.



## **Internet of Things: The Design, Implementation and Three-year Retrospective of an IoT Studio in a School of Business**

Christopher W. Starr, PhD  
Associate Professor of Information Management  
School of Business  
College of Charleston

### **Abstract**

Makerspaces, which are facilities with digital devices for product prototyping such as 3D printers, 2D and 3D cutters and injection molding machines, are now common in colleges and universities. Makerspaces can be found in centralized locations such as campus libraries or distributed in one or more specific academic units. Newer to university campuses are IoT facilities for student and faculty development of digitally enabled products that combine traditional makerspace tools for product prototyping and production with and digital sensors, computers and communication technologies. IoT enables physical things to have an internet presence, or digital twin, to create new value propositions for solution building. More recent advances in standards, security and cloud support for IoT, position IoT devices as distributed sensors for centralized decision support, to decision points driven by locally sensed data as edge computing devices.

Concomitant to the advent of the IoT makerspace is the increase in interface abstractions provided by vendor and open source tooling, decreasing the barriers to entry for undergraduate students across majors. The increase in accessibility makes IoT makerspaces accessible to business and liberal arts students without the prerequisite of a background in engineering or programming.

This paper describes how the makerspace at one liberal arts university reimaged and retooled a traditional makerspace to launch an IoT design studio. Quantitative outcomes are presented include the tooling decisions, budget, organizational framework, training, safety and utility across three years of running an IoT studio in a school of business. Examples of student products will also be presented.

Keywords: makerspace, Internet of Things, experiential learning, interdisciplinary, innovation, information systems

**Introduction**

Among academics and practitioners alike, there have been those who are especially curious about making physical things with hands and tools, including how existing things work and how to go about building new things. In the analog world of physical products, inventing and prototyping has deep educational roots in shop classes and school facilities that provided instruction and access to analog equipment such as welders, saws, drills, lathes, and other analog tooling associated with craftsmen and laborers of the 20<sup>th</sup> Century and earlier. With the advent of digital maker technologies such as 3d printers, CNC machines, and laser cutters, facilities for makers have become available and nearly ubiquitous in high schools, universities and communities across the United States. Never before has it been easier, safer and more satisfying for people to take an idea and make it manifest.

The transition from analog to digital tooling in makerspaces represented the first major leap in the architecture and service offerings for makerspaces. Computer controlled tooling reduced the barrier of entry for a wider user base of people who wanted to engage in the making of physical things. No longer did the use of makerspaces require physical strength, risk of injury, or long training periods to engage. In digital makerspaces, learning curves for tool deployment have been truncated due to better tool abstractions, and computer-controlled tools have improved tool reliability while lowering price points. These characteristics create new opportunities for university makerspaces beyond their early homes associated with engineering and STEM disciplines to now serve students and faculty across all disciplines, including business students.

This paper describes the next transition in makerspaces from facilities with computer driven tooling for the making of physical things to facilities for the making physical things with a digital presence – the Internet of Things. The case study is based on the design science approach, an outcomes-based information technology research methodology offering offers specific guidelines for evaluation and iteration within research projects (Simon, 1996). Following a brief literature review and the background for the case study, implementation framework for the case is defined, followed by the data and results section. Described is the facility, organization, funding and educational outcomes of the IoT makerspace in liberal arts university setting at the College of Charleston. The paper concludes with a conclusion, recommendations and future work.

**Literature Review**

The notion of the makerspace is rooted in the maker movement described by Dougherty (2012), in which the notion of a maker replaced the older vernacular of inventor and tinkerer, and as a result, expanding the appeal of making things to a broader audience over a broader age range including children. Makerspaces in education have also been referred to as fabrication laboratories, design studios and other terms that describe the common aspects of a shared space with shared tooling and services for student use.

For a review of a substantial body of literature for K12 makerspaces from 2000 through 2018, see Shad and Jones (2019). An review of 40 universities makerspaces was presented at the American Society for Engineering Education reporting on the organization, common tooling, the sponsoring campus organization, and the effect of the makerspace on university culture (Barrett et al., 2015).

The success and challenges of makerspaces at liberal arts universities is described by Beavers et al. (2019), Watson, et al. (2019) and Dahal (2019).

While the makerspace movement has been associated with Industry 3.0 through the use of digital technologies including computer assisted design and computer-controlled machinery, the IoT revolution with cloud computing and personalization has enabled the products produced by computer controlled prototyping tools to themselves be computer and network enabled (Lasi, 2014). Thus, makerspaces that support student makers in the prototyping of products with an internet presence, IoT products, are better characterized by Industry 4.0.

### Background

The College of Charleston is a public, liberal arts college of approximately 10,000 undergraduates that also a school of education and an AACSB accredited school of business located in the center of the historic city of Charleston, South Carolina, USA. The university includes the includes the basic sciences, computer science since 1980 and data science since 2005. The College of Charleston does not host a school of engineering.

The College of Charleston's makerspace was initially planned in the spring of 2016 as a faculty-lead, grass-roots project, following input from a makerspace workshop sponsored by Venturewell at Venturewell Open (March 2016) in which the directors of the MIT and Georgia Tech makerspaces shared best practices and advise to universities new to the campus-based makerspace movement. Prior to the formal launch of the College of Charleston makerspace in September 2016, the School of the Arts and the Department of Computer Science were already deploying 3d printers, welders and other tooling for exclusive use by their respective majors. This case study describes a campus-centric makerspace designed to serve students of all majors.

The College of Charleston's move to add a university makerspace for students lagged 17 of its 18 self-identified peer institutions. While the library had first option to host a makerspace, the option was not pursued. Using publicly available Web-accessible resources, the data in Table 1 was collected on August 19, 2017, showing the name and location of the makerspace found at each of the peer institutions with the exception of the University of Missouri-St. Louis, where no web-based evidence of a makerspace was identified. The type of makerspace was not investigated among the peer makerspaces, i.e., analog makerspace, digital makerspace, or IoT makerspace.

University Peer	Name of Makerspace	Location
Appalachian State University	Inspire Maker Lab	Library
Baylor University	Electronic Library	Library
Bowling Green State University	BiG Fab Lab	School of Business
Clemson University	Student Makerspace	Watt Innovation Center
College of Charleston	TIDE Studio	School of Business
College of William and Mary	Small Hall Makerspace	Physics Department
James Madison University	ICE Collaborative and Makerspace	School of Business
Miami of Ohio	TEC Lab	Library

Montana State University-Bozeman	MSU Makerspace	College of Engineering
Northeastern University	CAMD Makerspace	unknown
Northern Kentucky University	NKY Makerspace	unknown
SUNY-Geneseo	START-UP NY	School of Business
University of Maine	Hutchinson Center	School of Science and Mathematics
University of Missouri-St. Louis	No online evidence found	
University of New Hampshire	The Makerspace	UNH Center
University of North Carolina-Charlotte	Makerspace	Library
University of North Carolina-Greensboro	SELF Design Studio	School of Education
University of North Carolina-Wilmington	Curriculum Materials Center	School of Education
University of Northern Iowa	Makerspace	Library

Table 1: Makerspaces at peer institutions of the College of Charleston as of August 19, 2017.

### Implementation Framework

The following sections describe the makerspace architecture and implementation decisions made for the College of Charleston makerspace as an IoT studio. The implementation of the makerspace was significantly influenced by the makerspace documentation provided by Georgia Tech makerspace with concept influences by MIT's Fab Central.

#### *Mission*

The mission and associated vision statements for the IoT studio were defined to be congruent with the Maker Manifesto (Hatch, 2013). The defined audience included all majors on campus without restriction by major, rank, project type or student goals for making things. An emphasis was placed on student engagement and interaction at the intersection of disciplines.

#### *Organization*

The IoT studio is run by undergraduate students with strong operational and budget oversight by the faculty director. The studio is not a student club or sponsored by the student government organization. The studio is housed within the School of Business with a reporting line to the dean of the school. A student leadership team of is selected by the director from among students with the passion, interests, maturity, technical and leadership skills. Each student is responsible for assuming and executing their role on the team.

For planning, management and operations, five roles are defined as follows to describe the organization of the makerspace.

IoT studio Member: A student, faculty member or staff member who fulfill the membership requirements.

IoT studio Mentor: A student, staff or faculty member who has the skills to supervise members on one or more stations and is responsible for correct use of tooling and safety of users at that station. Mentors may have the knowledge to train mentors on one or more stations, signs off on new mentors and mentor advancement, and volunteers to run TIDES on a scheduled basis.

All mentors have two ratings, competent and expert. One is the member rating for the skill that member has on each of the tool stations (e.g., 3d printer, 3d scanner, soldering station, microcontroller station, microprocessor station, RFID station). The competent level allows mentors to supervise student users on particular stations. The second rating is the member's rating for their ability to train students on the use of stations. A mentor must have a rating of expert in order to train members and to supervise and train mentors.

IoT studio Executive: A student member of the leadership team who provides a leadership role for a particular duration, trains the next person for succession prior to vacating the role, and works directly with the studio's faculty and staff. Appointments are made or renewed annually.

IoT studio Faculty Advisor: One member of the College of Charleston faculty who has primary oversight of IoT studio. The Executive members have scheduled meetings and emergency contact information for the faculty advisor.

IoT studio Community Advisor: Community member, staff member or faculty member with professional expertise in one or more areas who has volunteered for a period of time to help in tactical and strategic planning and operations. A community advisor may also act in the role of mentor.

### *Membership*

All students, faculty and staff who use the IoT studio are required to be members of the studio. Membership responsibilities are defined in Table 2.

registered for membership
passed the technical training on the use of at least one station
passed the general safety training
passed the safety training specific to each station used
responsible for safe use of stations
responsible for the cleanliness of their station
responsible for the proper care of their equipment and supplies

Table 2: Membership responsibilities in the IoT studio

### *Funding and Budget*

Funding is accomplished annually through university operational funds and philanthropic sources. A budget request is made annually to the Dean's Office in the School of Business. A separate office handles philanthropic requests. The number of makerspace tools and services is limited by the

funding of the budget request. The budget includes line items for new tools, maintenance for existing tools and supplies. Supplies are categorized into general office and general IoT product prototyping. Students with defined projects may also request specific funding for projects that is included in the budget.

For the first three years of operations, no funding has been made available to pay student employees, thus the students who serve in the executive role for management and the mentor role for daily operations do not receive pay. Remuneration is in the form of special access for these students during times when the facility is closed for general student use.

#### *Space*

The IoT studio location was initially provided in a temporary location, central to the heart of campus which spans approximately 64 acres, some of which is non-contiguous. Space options which were off campus or far from student dormitories was avoided. A centralized location promoted three important characteristics: convenient student access, increased student safety, and high marketing visibility.

#### *Operations*

At least one student member who is also in the role of executive or mentor is present in the IoT studio during operational hours. All student members must card in and out of the studio using a custom designed, passive RFID-based membership activity system. Student users also record their project idea, goals and purpose for tracking the use of the studio and its services.

The IoT studio posts weekly hours of operations during weeks that the university is in session in the fall and spring semesters. The studio closes in the summer for maintenance, cleaning and upgrades and may be used by the student executives and mentors only. The determination of opens times and closing times was made by collecting member check-in and check-out data. Over time the best hours of operation were determined then constrained by the accumulative bandwidth available for staffing the studio by student executives and mentors.

#### *Services*

Services are provided through stations in the IoT studio. Stations provide a set of related services. Stations include Design, Cutting, Soldering, Printing, RFID and eight additional stations. A complete listing of services is given in Table 3. For example, the soldering station provides multiple types of soldering tools, solder, flux, clamps, optics, and safety gear on a non-combustible tabletop along with an assortment of wires, connectors, pliers, strippers, and other related tools.

Each station is labeled and comes with station specific safety and operational instructions. Students must obtain training from a mentor before the first use of a station and sign off on safety procedures. At this time no stations require vented hoods or special air handling because tooling has been selected with this constraint.

Services selected for inclusion during the first three years of operation are in Table 3. The services were selected with student, faculty and community mentor input and constrained by budget and

safety guidelines provided by the faculty director. Additional services were added through a partnership with a local community-based, non-profit makerspace.

Station	Services
Design	2d design, 2d design software and computers
Cutting	2d cutting (vinyl heat press, vinyl stickers)
Printing	3d printing (liquid resin photopolymers, molten polymers)
RFID	Passive, semi-active, active RFID, readers
Soldering	Soldering, cutting, cleaning
Molding	injection, community makerspace partner
Communication	RFID, WiFi, Bluetooth, NFC, cellular
Manufacturing	Small batch, community makerspace partner
Microcontrollers	devices, assorted sensors, communication modules and power supplies
Microprocessors	devices, assorted sensors, communication modules and power supplies
Cloud services	Server and middleware services and standards
Software development and testing	Compiled and interpreted language support
Entrepreneurship	grants and mentored site setup

Table 3: Services provided by the IoT student to members via designated stations.

#### *Skills Developed and Reinforced*

The overall student learning objective is to increase technical agility as an individual and often as part of a lean development team. Technical agility is defined as the “agile software engineering principles and practices teams use to deliver solutions quickly and reliably” (Scaled Agile, 2020).

The IoT studio helps students in the development and reinforcement of multiple ways of thinking about problem spaces and the designs of solutions. The four ways of thinking taught in the IoT studio are: design thinking, analytical thinking, systems thinking, and computational thinking (Easterbrook, 2014).

Academic skills developed and reinforced include programming (compiled and scripted), materials, information (information architecture, databases, cloud services), and privacy and security techniques. Students are encouraged to leverage their passions in concert with what they bring to the studio from the coursework in their respective majors and to cross train with students in complementary skillsets.

#### *Credit*

Students do not currently receive academic credits for their participation in the IoT studio as members, mentors or executives. Project-based activities associated with the requirement of an academic course or program may indirectly receive recognition and academic credit by way of that association. For example, during the first three years of operation, two students from computer

science received special topics credit for courses delivered in the studio on topics related to IoT and RFID. Certifications and open badges have been considered but were not offered in the first three years of operation.

### Data and Results

Data from year two (2017-2018 academic year) was collected and aggregated for this case study as this was a full year of stable-state operation of the IoT studio. The first year was a startup year complete with setup, equipment orders and other complications of getting a facility running with marketing for student awareness and engagement. The third year was truncated due to a requirement to physically pack up the facility until a new location was designed and constructed within the footprint of the School of Business.

### Students

A total of 79 students participated in the IoT student in the second year. A listing of student members by major count is given in Table 4. A major is shown in the table unless at least one student member reported that major. In total 28 business students and 51 students from majors outside of business participated.

Academic Major	Student Member Count
Anthropology	1
Arts Management	1
Astronomy	1
Biology	4
Business Administration	16
Communications	2
Computer Info Systems	12
Computer Science	17
Computing in the Arts	4
Continuing Education	1
Data Science	5
Economics	1
Finance	5
Historic Preservation	2
International Business	6
International Studies	1

Table 4: Student members of the IoT studio by major course in the second year of operation.

The table includes all student members including those who served as mentors and executives in the organization. Twelve faculty and administrators have been involved in the project as either active members of the studio or as supporters of the idea including faculty, department chair, the dean of the business school and the president of the university. In addition, seven community



members from industry, community makerspaces and high school faculty joined the IoT studio to advise and to mentor.

In each of the three years, a total of \$10,000 was supplied by the School of Business for annual operations. Expenditures are divisible into three categories of new tools, supplies and pizza for student recruitment and project/prototype launches. The approximately cost per student user was \$127 per year.

#### Services and Tool Support

The IoT studio purchased the tools listed in Table 5 in the first and second years of operation and developed the partnership with a community makerspace for added services not available on campus.

Services	Tools Purchased and Supported
2d design, 2d design software and computers	iMac computers, open source and vendor design software tools and SaaS
2d cutting (vinyl heat press, vinyl stickers)	2 vinyl cutter2 (heat press and sticker vinyl)
3d printing (liquid resin photopolymers, molten polymers)	3 PLA printers, 2 resin printers
Passive, semi-active, active RFID, readers	Stock of three RFID types; transponder, RFID controller software
Soldering, cutting, cleaning	3 soldering sets and associated peripherals
Injection, community makerspace partner	NA
RFID, WiFi, Bluetooth, NFC, cellular	Compatible with Arduino and Raspberry Pi
Small batch, community makerspace partner	NA
devices, assorted sensors, communication modules and power supplies	Arduino microcontroller family
devices, assorted sensors, communication modules and power supplies	Raspberry Pi family
Server and middleware services and standards	AWS
Compiled and interpreted language support	Java, C#, Python and visual programming

Table 5: The services provided directly and through a partnered community makerspace and the tools purchased to enable the services.

#### Product Examples

Four successful student projects are given among the many projects that included jewelry making and T-shirt company formation. While interesting projects are celebrated, it's the iterative work by passionate students that mark the success or failure of the IoT studio.

#### Smart Kayak Paddle

2018: Senior business student developed kayak paddle blade (Figure 1) made from recycled plastic #2 and #4 bottles (HDPE and LDPE grade plastic).

The student figured out how to take plastic bottles out of the recycle bins in the School of Business and through injection molding create kayak paddles for the market. His invention is novel in two ways. One, instead of the plastic bottles having to go to the recycle center to be palletized, he obtained a woodchipper from a home supply store, chipped the bottles into plastic pieces which were then melted and injected. Two, he considered ways to add a small microprocessor into the shaft of the kayak handle and a strain gauge into the blade to create the paddle as an IoT device. This would allow the paddle to communicate with a smartphone application via the cloud server to record stroke power, frequency, and cadence. The app could also gamify kayak paddling with other kayakers.



Figure 1: 3d design of a kayak paddle blade for injection molding using water bottles from campus. (Autodesk Fusion 360)

#### *Predictive Keg Technology*

2017: Four students (computer science, data science, and business) and a faculty member designed a system that coffee/beer kegs sit upon to periodically measure their weights at short time intervals. Communicating with a cloud server and machine learning, the data was used to predict at least a day ahead when the keg would most likely be empty, automatically generating a reorder of that keg's contents. While systems exist for bars using regular size kegs, the advent of smaller kegs and kegerators distributed in businesses and across golf courses and other highly distributed areas made keg replacement difficult and expensive because kegs would have to go empty prior to supply chain notification. The keg then would not be replaced for a time equal to the order and delivery cycle. The Predictive Keg streamlined the supply chain using IoT with machine learning so that pony keg businesses can scale with more satisfied customers.

#### *Passive RFID Student Check-in System*

2017: Senior student (computing in the arts) created a new RFID system to allow members of ProtoX two sign in & out of the facility. Passive RFID stickers were attached or embedded to 3d printed plastic ID cards. Each static RFID number was associated with the student to which that card was issued. The software was written and deployed with an RFID reader so that students could walk into the IoT studio door and be logged into the facility automatically and walk out of the door to be logged out. Because the reader was sufficiently powerful, students did not have to take their ID card out of their pockets. An RFID engineer from a local aeronautics company mentored in this project.

#### *City Flood-Mitigating Blocks*

2017: Senior student (business) designed a plastic version of brick made out of recycled plastic. The blocks are able to capture water in a rainstorm then slowly release the water over days after the

rain ends. With garden walls and driveways made from this brick, cities like Houston Texas could mitigate the impact of catastrophic rain events.

#### *Smart Recycle Bins*

2015: Two students (computer science) and a faculty member designed a robust measurement device to measure the contents of recycle bins regardless of content. The device communicated data to the cloud where a prediction was made on a continuous basis to know when each recycle bin would be full in the future. This allowed for a new routing algorithm to be developed so that the employee who empties the recycle bins across campus would only go to recycle bins that were in need of emptying and do so in the shortest path possible around campus. The routing prevented the employee from having to open and inspect bins that did not need emptying saving more than 50% of his time in route. The product was developed with an Arduino processor, acoustic sensor, WiFi communication and a power supply for each bin. Dykstra's shortest path algorithm was used to route the employee between full cans. Product prototyping and testing was supported by the Office of Sustainability at the College of Charleston.

#### **Lessons Learned**

From this case study of the design and three-year implementation experience of the IoT studio in the School of Business at a liberal arts university, successes and failures lead to lessons learned that can be shared and studied. The following list is such a contribution stated without substantiation and should be interpreted with care as lessons from this case study may only apply to this case and not be generalizable.

- Start now to create an IoT studio at your liberal arts college or university. Do not wait for a top-down mandate to create an IoT studio for student learning experiences. Technology continues to advance in power, reduced cost and interface abstractions, and the need for technical agility among university students continues to increase in importance for career success.
- Seek champions in the upper levels of the administration and in the community who can provide supportive political leverage when hard decisions need to be made.
- Create a sustainable IoT studio that will outlive the founder(s). Share ownership and open source the studio to other passionate faculty and staff leaders and visionaries on campus. Other faculty must be given ownership of the studio for collaborative teaching and research opportunities.
- Integrate sustainability into student thinking and the project ideation. Products that solve a problem and at the same time help the planet and humanity are game changers.
- Hire student workers. Student workers are more dependable if they get a paycheck. Student volunteers are effective, but to keep them on task requires more energy from the faculty director.
- Operational hours might include non-business hours, such as nights and weekends as students may be in class during business hours. Find the peak demand periods and adjust opening hours accordingly. Be careful not to bias hours towards a certain sub-market. Err on the side of inclusivity.
- Recognition and awards including credit should be considered for learning outcomes and behaviors that model success outside of the university. Most makers do not need an

external reward, but rewards are the academic currency of the university. Consider offering technical certification(s) and open badges for student accomplishments.

- Leverage the studio for additional community development with professionals for mentoring, companies for job placement, and both for philanthropic support.
- Brand the facility and market it to students, parents, alumni and anyone else who seeks to support student engagement through experiential learning with impact.
- Host protathons, like hackathons and startup weekends, to encourage spirited engagement by groups of students in a concentrated time period.
- Use 1-day pop-ups on campus throughout the year to engage future members with a maker tool and what making is all about.
- Host senior projects and capstone projects for students in one or more majors to better connect the studio with academic study.
- Adhere to safety policies and enforce rules. Taking risks is what makers do when they iteratively build and learn. Reducing injuries and risk of injuries keeps the iterative focus on problem solving through invention.
- Seek student members from all disciplines on campus. Celebrate makerspace diversity.
- Discourage an IoT studio in every silo. The interdisciplinary engagement is a core value of the studio which in turn makes the studio a university asset for students and faculty members that crosses all disciplines.
- Leverage secondary effects including student recruitment into the university, student recruitment into majors, community engagement, internship development, company formation and career placement opportunities.

### Conclusions

The IoT studio in this case study has had startup successes and challenges. As a grass-roots effort with strong top-down support and funding, the studio attracted approximately 80 students from 16 different majors in year two, its first full academic year of operation, to work on projects of their own choosing without any credit within a faculty run by volunteers. The community of supports has been strong from local businesses and industry particularly for planning and mentoring. Philanthropy also influenced the studio by adding the entrepreneurial station and services so that students can now set up an ecommerce site to sell and test the market for their products.

The nature of the liberal arts is celebrated in the IoT studio where any majors in the arts and sciences can take an idea from conception to production while learning something about business and technology. The IoT studio has become another experiential learning platform that effectively celebrates and to some extent reimagines the creativity and critical thinking developed in the liberal arts tradition.

### Future Plans

In 2019, a new facility was designed specific for an IoT space. Shown in Figure 2, the glass-clad room is shown in diagrammatic form with seating for 16 in the front room. Behind the door is a sound-insulating room for noisier devices (e.g., CNC cutter, water jet cutter) and devise that emit smoke or fumes (e.g., laser cutter).

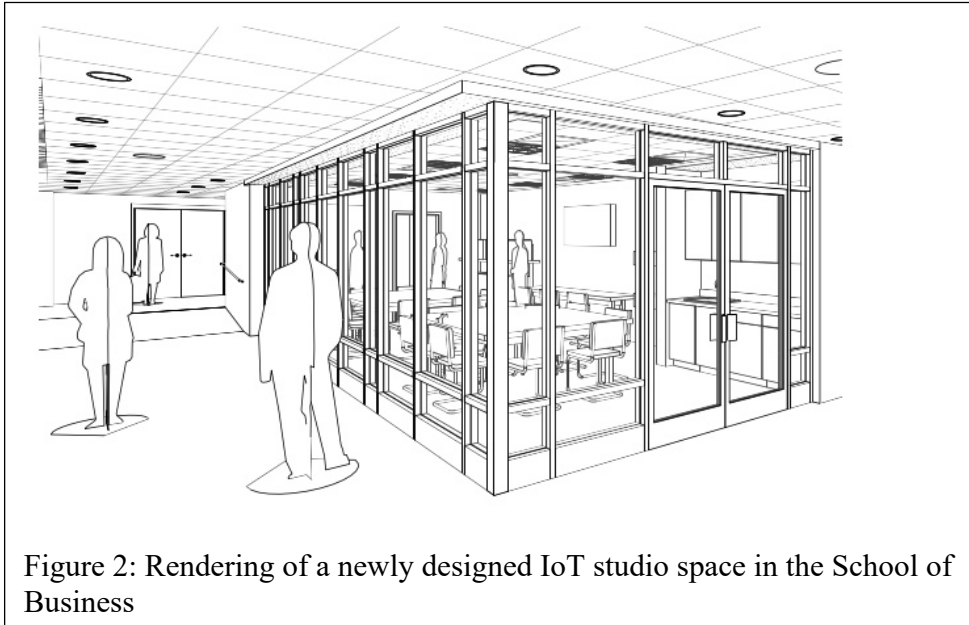

The IoT studio plan for 2020-2021 is to increase the budget, intergrade faculty and coursework, and expand services. The budget will increase from \$10,000 to \$30,000 annually to cover the cost of student employees and additional services. Faculty members will be recruited to host student projects in the IoT studio to bridge experiential and academic learning. Services under consideration include subtractive manufacturing, distributed manufacturing, logistics simulation, supply chain simulation, augmented reality, and automation through edge AI in IoT products. The new facility will be approximately 600 square feet. While smaller than the first, temporary space, the new room is designed to hang printers and cutters on the wall to save floor space.

### References

- Barrett, T., Pizzico, M., Levy, B., Nagel, R., Linsey, J., Talley, K., Forest, C., & Newstetter, W. (2015). A Review of University Maker Spaces. *2015 ASEE Annual Conference and Exposition Proceedings*, 26.101.1-26.101.17. <https://doi.org/10.18260/p.23442>
- Beavers, K., Cady, J. E., Jiang, A., & McCoy, L. (2019). Establishing a maker culture beyond the makerspace. *Library Hi Tech*, 37(2), 219–232. <https://doi.org/10.1108/LHT-07-2018-0088>
- Dahal, M. (2019). *Faculty Perception of Makerspaces* [M.S., Tufts University]. <https://search.proquest.com/docview/2240026999/abstract/1E3E44F467B14E68PO/1>
- Dougherty, D. (2012). The maker movement. *Innovations: Technology, governance, globalization*, 7(3), 11-14.
- Easterbrook, S. (2014, August). *From Computational Thinking to Systems Thinking: A conceptual toolkit for sustainability computing*. ICT for Sustainability 2014 (ICT4S-14). <https://doi.org/10.2991/ict4s-14.2014.28>

Starr, C. W.

Page 14 of 14

Hatch, M. (2013). *The maker movement manifesto: rules for innovation in the new world of crafters, hackers, and tinkerers*. McGraw Hill Professional.

Scaled Agile (2020). Team and Technical Agility.  
<https://v46.scaledagileframework.com/team-and-technical-agility/>  
accessed February 4, 2020.

Schad, M., & Jones, W. M. (2019). The Maker Movement and Education: A Systematic Review of the Literature. *Journal of Research on Technology in Education*, 1-14.

Simon, H. A. (1996) Sciences of the Artificial. *The MIT Press*.

Watson, D. K., & McGrane, L. (2019). Maker Arts & Making Space in the Liberal Arts.

Lasi, H., Fettke, P., Kemper, HG., et al. (2014) Business & Information Systems Engineering 6: 239.  
<https://doi.org/10.1007/s12599-014-0334-4>

**DEVELOPING GRIT THROUGH SELF-ACTUALIZATION: UNDERSTANDING HOW LOGISTICAL, COMMUNICATION, AND INFORMATION APPLICATIONS INFLUENCE THE HIERARCHY OF NEEDS**

Pamela Galluch Schlosser, Business Administration and Economics Department, Roanoke College, 221 College Lane, Salem, VA, 24153, schlosser@roanoke.edu  
Gulfem Kutlu, Business Administration and Economics Department, Roanoke College, 221 College Lane, Salem, VA, 24153, kutlu@roanoke.edu

**ABSTRACT**

Since the explosion of smartphones into society, Smartphone Applications, referred to as “Apps,” have flooded the online market. This paper redefines Maslow’s hierarchy of needs and determines where Apps can help facilitate or hinder our ability to meet each need. Specifically, we look at Logistical, Communication, and Information type Apps and see how each type affects our needs. We also investigate which need helps establish Grit, which is the ability to develop a perseverance and passion for satisfying long term goals. After collecting preliminary data through an online survey, we found that many applications do help us meet our needs, in particular Logistic and Information type Apps. We also found that Communication Apps hinder our ability to meet our social needs, suggesting that social media type Apps can actually make us feel less included. Finally, we found that Grit can be developed through self-actualization.

**INTRODUCTION**

Since the explosion of smartphones into society, Smartphone Applications, referred to as “Apps,” have flooded the online market. Because of technology, individuals are having to vet through a higher number of daily notifications, be it for personal, home, or work. This innately increases an individual’s daily demand, where because of technology, individuals are responsible for more and more.

Because this “always-on” state of being, we use Apps to try to help us alleviate this burden, giving us access to travel information, shopping sale sites, financial information among others. In 2019, the Apple App Store offered over 2 million Apps for download onto smart devices [5]. There were also 194 billion Apps downloaded in 2018, which was dramatically up from 2017 [14]. Messaging Apps and Social Media Apps still hold a top spot in app to be downloaded, which includes Apps like Facebook and Facebook Messenger, Instagram, and Snapchat [24]. It is no doubt that applications are in abundance, and because of that are also the new way people use to get and organize their information, communicate, and help them travel from place to place.

Abraham Maslow proposed one of the best known motivational theories in psychology which defined our needs at 5 levels: 1) physiological or personal, 2) safety, 3) belonging, 4) esteem, and 5) self-actualization needs [22]. Since this paper was published in 1943, access to food

and water along with an overdependence on technology has changed the way we assess our needs. A main motivational goal he suggested was to eventually find our “ideal self” and be “self-actualized.” While that point is still valid, we argue that coping with the increased pressure technology brings has changed what constitutes an ideal-self to something that may be out of reach for most people.

The pressure to work faster, maintain an active presence in family life, and make more money can make it difficult to satisfy one’s own personal (physiological) needs (sleeping, eating, hydrating, etc.). The popular press has suggested opposing views in regards to the relationship between Maslow’s motivational needs and technology: mainly that 1) technology cannot help you satisfy your needs because it does not explicitly provide food or shelter, and that 2) technology does help you satisfy your needs through social connectedness. We argue a third point, that, since the proliferation of technology, we use technology as a way to facilitate the satisfaction of our needs and alleviate the logical, social, and informational burden we have in an “always on” day and age.

This means that while we have increasing demand, we can use technology as a way to connect to others, to get information, and to simplify our daily routines. For example, now, instead of shopping at the grocery store, we can use Amazon’s subscription services to order groceries for us, eliminating the need for us to go to the grocery store that would provide access to satisfying our physiological needs at a later time. Instead of going to the library and finding information, we can use Google scholar to quickly answer our own questions.

The usefulness of Apps in aiding our overall motivations has been under-researched. Only snapshots of how technology affects Maslow’s model has been empirically studied. For instance, some have researched whether continued use of social media can explain ones social needs or self-actualization [3]. Others have limited their research to the aging population and examined how technology adoption could serve as an outcome to having certain needs [30]. Beyond developing self-actualization, it is also important to look at one’s needs alongside what people ultimately strive for [25]. The holistic network outlaying how technology can help facilitate our needs is important and the development of further motivational goals is necessary as we get bogged down with increased demand. A number of studies have theorized models through Maslow’s motivational lens, but measured traits such as resilience or anxiety as predictors of self-esteem [2]. We look at grit as an outcome and suggest that not giving up when challenged is a key idea that people can strive for outside of the motivational needs presented by Maslow. Therefore, we ask the following two research questions: *1) How do applications affect our motivational needs? and 2) How do our needs help us establish grit as a form of resilience?*

Our article is organized as follows. First, we present a “Theory of Human Motivation” and provide a critical evaluation of Maslow’s hierarchy of needs. Second, we discuss social technologies and theorize how IT has impacted our ability to achieve our needs. Third, we predict that certain Apps aid in facilitating our needs, while others hinder our ability. We also predict that self-actualization can help build grit. Fourth, we present our methods



describing our survey procedure. We finish with a presentation of the preliminary results, followed by a conclusion.

## LITERATURE REVIEW

### Maslow and "A Theory of Human Motivation"

According to Maslow's 1943 seminal paper "A Theory of Human Motivation", humans have five categories of needs presented in a hierarchy [22]. Table 1 presents each of the 5 needs along with their innate characteristics.

The first level of needs are basic needs, which is also known as physiological needs, including the need for food, water or sleep. Maslow classified these physiological needs as the needs that are the most essential to living. These needs are important because they are required to be met so that the body can function properly, and these needs should be met first, so that other needs may be carried out. This indicates that if an individual is really hungry, it would be hard to focus on anything other than food, and that an individual would push aside any other need until the basic needs are satisfied.

Table 1. Maslow Hierarchy of Needs	
Need	Characteristics
Physiological	Food, water, air, shelter, clothing, sleep
Safety	Personal and financial security, employment, health
Belonging	Love, friendship, family, intimacy, sense of connection
Esteem	Self-esteem, confidence, recognition, achievement, respect by others
Self-Actualization	Achieving one's full potential, creativity, morality

The second level needs are classified as safety needs, which consist of seeking safety, security, and stability. These needs include personal, emotional, and financial security as well as the need to be healthy and have a good well-being.

The third level needs are classified as belonging needs, which includes interpersonal relationships with family and friends as well as romantic partners. It will also cover intimacy and affection needs.

The fourth level needs are classified as esteem needs, which consists of not only self-respect and self-esteem but also receiving respect and esteem from other people. When esteem needs are filled individuals will feel confident, important, and valuable.

Finally, the last and highest-level need is self-actualization, in which people will aspire for self-fulfillment, and seek to realize their personal potential. According to Maslow achieving self-actualization is very rare and only 2% of the people reached to this stage.

### Critical Evaluation of Maslow's Hierarchy of Needs

Although Maslow's theory of hierarchy of needs still remain one of the most popular theories in psychology, it has received a good amount of criticism as well. Maslow himself refined his

theory over time. For example, Maslow's original theory of human motivation actually included 2 more levels of needs. These were cognitive needs and aesthetic needs. Cognitive needs are the need to know, to understand, and to discover. Aesthetic needs are the needs for order, cleanliness, and beauty. In 1966, Maslow added another level of needs, the transcendence needs to his model [21]. Transcendence are values beyond personal self, such as religious faith and so on. However, as time went on, Maslow focused mostly on only the first five level of needs and that's the model that is widely accepted today.

Maslow also clarified that the hierarchy of needs isn't as rigid as his original paper made it seem like. It is possible that a human behavior can satisfy more than one need at the same time and it doesn't need to be a step by step process [20]. Also, people don't need to completely satisfy a need before the next level needs emerge. Maslow also stated that the order of needs might be different for each individual based on the differences in personality and external factors.

Several other researchers also extended on Maslow's hierarchy of needs. For example, Eckerman [12] added a new need called consistency need. He stated humans need consistency of feeling, knowing and acting. Alderfer [1] developed a similar motivational needs theory that consists of existence, relatedness, and growth needs. According to his research, the existence needs would cover all basic material and physiological needs. Relatedness needs involved relationships with others. Growth needs consists of desire to be creative and productive. In more recent research, Kenrick et al. [16] focused on the self-actualization and disaggregated self-actualization to lower levels in their revised model.

From global perspective Maslow's theory was criticized of being western culture focused but research showed support for Maslow's theory across different countries and cultures [7, 29]. According to Tay and Diener [29] human needs were consistent among the cultures however the order of the needs differed across nations. Furthermore, their research confirmed that people focus on the lower level needs first; however, they didn't need to completely satisfy those needs before fulfilling higher level needs. Their findings provided support for Maslow's revision that people might be simultaneously working on satisfying different level needs.

### **Modernizing Maslow With Technology**

Nowadays it is impossible to imagine life without Internet. Technology, digital tools, and mobile devices have been a very important part of our lives. This reality brings up an important question: *Is Maslow's theory still relevant or should the theory be updated according to today's digital world?*

There is no doubt that technology has changed our lives both positively and negatively. For example, improved and better communication technologies can help us connect with others easily. However, this level of connectivity and access raises online security and privacy concerns as well. Similarly easy access to information is one of the strengths of technology but individuals can also experience information overload [8]. There is no

question that the technology will affect how humans satisfy their needs, but will technology actually help or hurt our quest to satisfy our needs?

Figure 1 presented the overall research model, which suggests that certain applications affect different needs and that self-actualization, the highest need affects one's grit. In our research, rather than focusing on individual Apps, we opted to group them into 3 main categories as Logistical Apps, Communication Apps and Information Apps.

Logistical Apps are applications that help alleviate the cost of finding and getting products, services, and information. We classified Driving Apps, Shopping Apps, Travel Apps and Food Delivery Apps as Logistical Apps. This means that Driving Apps, like Ways or Google Maps, help you move around town at ease, thus lessening the cognitive resources we use to dedicate to memorizing our way around. Shopping Apps help us get products that we want with ease. Amazon provides services like "try before you buy" so that you can have items shipped to you, try them on, and return them without even leaving your home. Travel Apps give you access to planes, hotels, and things to do, which eliminates the hassle of finding a travel agent, or researching a place in an almanac or travel book. Finally, Food Delivery Apps, like Hello Fresh or Blue Apron, have become in abundance because it brings food to the table that can be typically cooked in 30 minutes or less. Other types of food Apps, like Grubhub or DoorDash, have also started to deliver food to you, eliminating the need for you to leave your home.

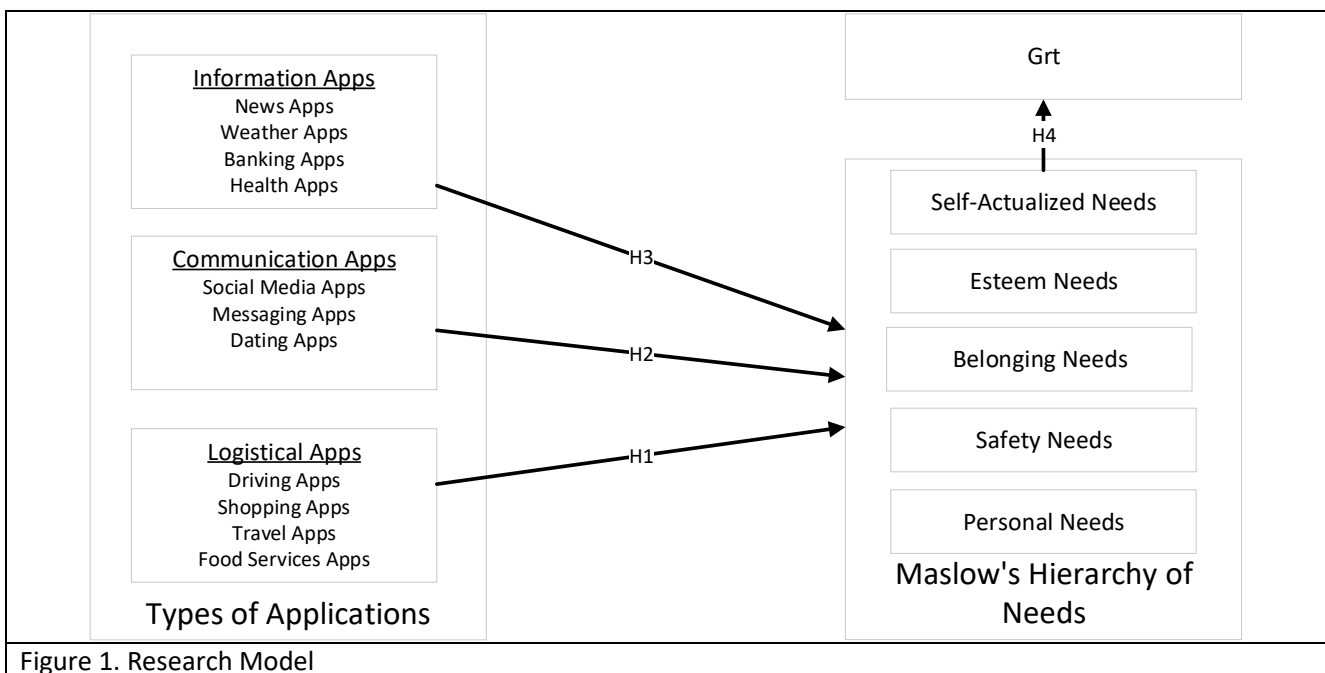

Figure 1. Research Model

Based on Maslow's revision of his theory and supporting research, we reject the notion of a rigid structure of specific Apps only satisfying one level of need. For example, Mokhtarian, Salomon, and Singer [23] examined travel demand and argued travel for grocery shopping will satisfy psychological needs, whereas travel for curiosity would satisfy self-actualization

needs and so on. Therefore, we proposition depending on how and why a Mobile App is used, it can satisfy more than one level of need. Given the nature of the Logistical Apps, it is logical to infer that they will affect almost all of Maslow's hierarchy of needs. However due to the impersonal nature of the Logistical Apps, they cannot help satisfy the belonging needs. Therefore, the first set of hypotheses are:

*Hypotheses 1a: The use of Logistical Apps positively affects personal needs.*

*Hypotheses 1b: The use of Logistical Apps positively affects safety needs.*

*Hypotheses 1c: The use of Logistical Apps positively affects esteem needs.*

*Hypotheses 1d: The use of Logistical Apps positively affects self-actualization needs.*

Communication Apps are applications that help us connect to people socially. We classified Social Media Apps, Messaging Apps, and Dating Apps as Communication Apps. Facebook, Instagram, or Snapchat are examples of Social Media Apps that allow people to read, post, and like messages or pictures. Messaging Apps, like Facebook Messenger or GroupMe, allow us to communicate readily with people which is why this grouping of Apps was the most downloaded type of Apps in 2018 [24]. Dating Apps, such as Tinder, are also becoming increasingly popular for people to meet others who are like minded.

Communication Apps make it easy to find and reconnect with an old friend, communicate in real-time, share your life with hundreds of your friends and followers. Will these online friendships and interactions bring happiness and genuine human connection to our lives? Or are they actually so superficial that they would end up making us feel sad and lonely?

Research findings have been inconsistent in this topic. For example, according to Ellison, Steinfield, and Lampe [13] greater use of Facebook will bring you more social capital. This could especially be helpful for individuals that experience low self-esteem and low life satisfaction. On the other hand, Kross et al. [17] found use of Facebook undermines individual's well-being. The more individuals used Facebook, the less was their life satisfaction.

Tobin et al., [31] found high levels of engagement on Facebook created a sense of connection and lowered the levels of social loneliness. However, the individuals that received no comments, likes, or shares on their posts reported lower levels of self-esteem and belonging. Furthermore, individuals who did not actively post also reported lower levels of belonging [31]. This was supported by another research that showed people lose sense of belonging if they are ignored over the Internet [33].

According to a 2012 survey by Anxiety UK, people reported lower self-confidence when they compare their achievements to the achievements of their online friends. Also, more than half (51%) of the survey participants said the use of social media negatively impacted their behavior [9].

The literature discussed here suggests that the Communication Apps may not actually help people reach their higher order needs of belonging and esteem. Instead, they will negatively affect them. This leads to the next set of hypotheses:

*Hypothesis 2a: The use of Communication Apps negatively affects belonging needs.*

*Hypothesis 2b: The use of Communication Apps negatively affects esteem needs.*

Information Apps are applications where we search for information to help us make decisions. We classified News Apps, Weather Apps, Banking Apps, and Health Apps underneath the broad umbrella of Information Apps. In each of these types of applications, individuals search for data to help handle their day to day activities, ranging from looking up the weather to help inform them whether to wear a jacket or not, or to looking up financial status to help decide whether we can spend more or less.

According to a survey done by Mashable [26], the majority (84%) of the respondents felt happiest online when learning about the world. More than 70% of the respondents said they feel happy online when they are feeling intellectually engaged. Furthermore, expressing themselves creatively also made the respondents happy [26].

Kaufman [15] set out to test Maslow's theory that self-actualized people will be motivated by growth and exploration and they will experience greater life satisfaction and psychological well-being. According to his findings, self-actualization was significantly correlated with curiosity, life satisfaction, personal growth, self-acceptance and positive relations [15].

This is the reason why the Information Apps not only provide us the necessary information and tools to contribute to our personal growth and self-actualization journey but it will also result in happier individuals and better relationships with others. This leads to the next hypotheses:

*Hypothesis 3a: The use of Information Apps positively affects belonging needs.*

*Hypothesis 3b: The use of Information Apps positively affects self-actualization needs.*

Resilience has been defined as a personality characteristic that suggests a person can face challenges or adversity and push through. Grit subsumes the idea of being resilient, while extending it further to also examine whether people have focused passions over long periods of time [11]. Therefore, a person who is gritty would not only be resilient where they are expected to overcome obstacles, but they would also keep their interests when things get too difficult.

The popular press is flooded with articles on millennials and grit, suggesting that their grit is at an all-time low [10]. This is important because grit has been consistently shown to be a moderate predictor of success and a strong predictor of retention [6]. A lack of grit can have an all-time effect on work ethic, where if work gets challenging, people are more likely

to turn over and quit [10]. While researchers tend to look at the correlates of our outcomes from having grit, little research has shown how to develop it.

Comparing Maslow’s hierarchy of needs to the development of grit, we would argue that grit can only be developed after satisfying the highest need, self-actualization. Self-actualization is defined conceptually as living up to one’s potential [20], and operationally as being comfortable with oneself while living the way they want to live [28]. We argue that one needs to feel self-actualized before developing grittiness as a trait. Based on this, we propose the following hypotheses.

*Hypotheses 4: Self-actualization positively affects one’s grit.*

Figure 2 summarizes our formal research model, which outlines our specific hypotheses.

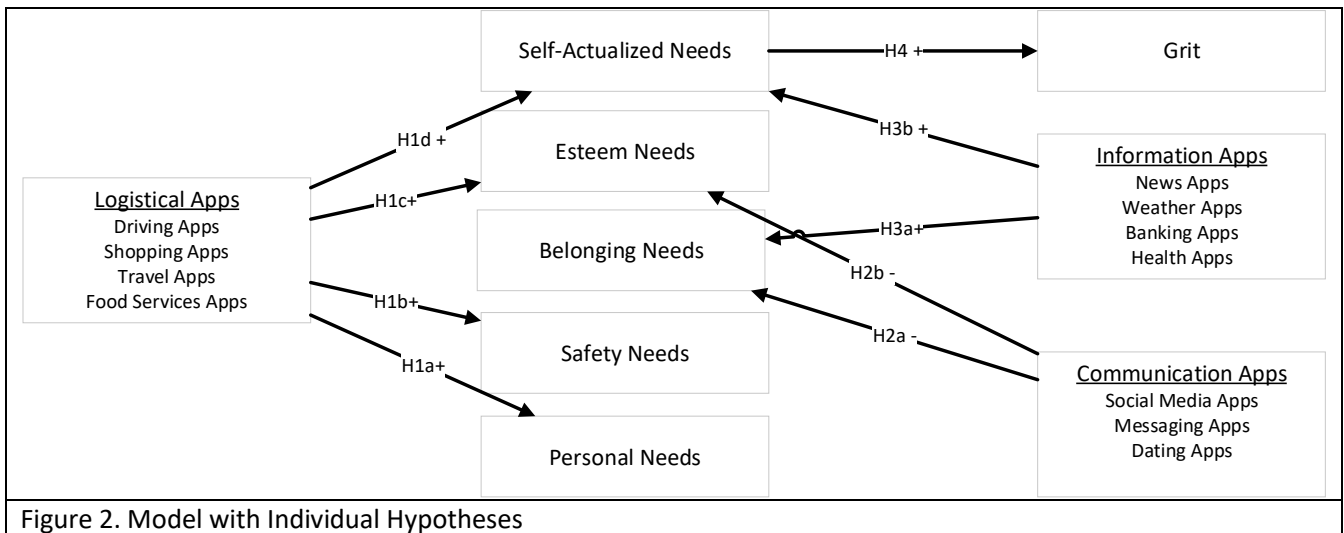

## METHODS

In a preliminary data collection, 90 individuals from a small liberal arts institution completed a survey on application usage and needs. Our sample profiles are outlined below in Table 2. The profiles of technology and social media usage was measured from items developed from Rosen (2013). We asked about general information and communication technology (ICT) usage including actions like sending and receiving emails, making phone calls, or receiving texts messages. Besides playing games on an electronic device, the majority of our sample was heavy users of technology, with most using ICT at least weekly. We also asked about general social media usage including actions like checking your social media, posting status updates, or posting photos. Over half of our sample checked social media, read postings, or clicked “like” to a posting at least several times a day. Actual posting results were more spread between never to at least every hour, suggesting that our sample varied widely on these measures. We also asked about the size of the network each participant had. 47.7% of our sample had over 500 friends. 73.8% of our sample knew at least 100 people in person

that were on their social media account. Finally, 93.2% of our sample talked to at least one of their social media friends weekly.

General Technology Usage	Never	Once a Month	Several Times a Month	Once a Week	Several Times a Week	Once a Day	Several Times a Day	At Least Every Hour
Send, receive and read e-mails (not including spam or junk mail).	0	2 (2.3%)	2 (2.3%)	4 (4.5%)	7 (8.0%)	3 (3.4%)	39 (44.3%)	31 (35.2%)
Send and receive text messages.	0	0	1 (1.1%)	0	7 (8.0%)	4 (4.5%)	23 (26.1%)	53 (60.2%)
Make and receive phone calls	0	3 (3.4%)	3 (3.4%)	2 (2.3%)	29 (33.0%)	21 (23.9%)	17 (19.3%)	13 (14.8)
Watch TV shows, movies, etc.	4 (4.5%)	9 (10.2%)	5 (5.7%)	8 (9.1%)	15 (17.0%)	25 (28.4%)	17 (19.3%)	4 (4.6%)
Browse the web.	0	1 (1.1%)	4 (4.5%)	1 (1.1%)	9 (10.2%)	6 (6.8%)	27 (30.7%)	33 (37.5%)
Play games on an electronic device by yourself.	23 (26.1%)	10 (11.4%)	9 (10.2%)	10 (11.4%)	10 (11.4%)	8 (9.1%)	13 (14.8%)	5 (5.6%)
<b>Social Media Usage</b>								
Check your Facebook page or other social networks	7 (8.0%)	2 (2.3%)	1 (1.1%)	2 (2.3%)	6 (6.8%)	11 (12.5%)	34 (38.6%)	25 (28.4%)
Check your social media at work or school	10 (11.4%)	4 (4.5%)	0	3 (3.4%)	4 (4.5%)	6 (6.8%)	33 (37.5%)	28 (30.7%)
Post status updates	27 (30.7%)	21 (23.9%)	18 (20.5%)	9 (10.2%)	7 (8.0%)	3 (3.4%)	1 (1.1%)	2 (2.3%)
Post photos	16 (18.2%)	31 (35.2%)	23 (26.1%)	9 (10.2%)	7 (8.0%)	1 (1.1%)	0	1 (1.1%)
Browse profiles and photos	9 (10.2%)	7 (8.0%)	7 (8.0%)	5 (5.7%)	15 (17.0%)	12 (13.6%)	20 (22.7%)	13 (14.8%)
Read postings	6 (6.8%)	6 (6.8%)	3 (3.4%)	2 (2.3%)	11 (12.5%)	14 (15.9%)	28 (31.8%)	17 (20.4%)
Comment on postings, status updates, photos, etc.	18 (20.5%)	10 (11.4%)	7 (8.0%)	9 (10.2%)	19 (21.6%)	10 (11.4%)	11 (12.5%)	4 (4.5%)
Click "Like" to a posting, photo, etc.	7 (8.0%)	3 (3.4%)	6 (6.8%)	4 (4.5%)	11 (12.5%)	7 (8.0%)	24 (27.3%)	15 (28.5%)

## Measures

The two most important criticisms towards Maslow's hierarchy of theory suggest that 1) it is difficult to empirically test it and 2) the attempts to test it do not provide consistent results. Wahba and Bridwell [32] showed partial support for low-order and high order of needs hierarchy. They believed Maslow's hierarchy of needs theory was almost non-testable as it was very hard to determine which behavior should be included in each a category. Strong and Fiebert [27] and Lester [18] also attempted to develop scales to measure Maslow's hierarchy of needs. Strong and Fiebert [27] measured how important each need was whereas Lester [18] assessed if the five needs were satisfied in the respondents. In 2013, Taormina and Gao [28] conducted an empirical testing of Maslow's hierarchy of needs. Their work included defining the needs for Maslow's theory and scale development. For each need level, they developed multi-item scales to assess the satisfaction of the respondents. They ended up with a 72-item scale to measure the five levels of needs hierarchy. Their research results showed strong support for construct validity of the scale as well as support for Maslow's hierarchy of needs theory. According to the data analysis, all correlations among the satisfaction of needs were statistically significant and positive, and findings were consistent with hierarchical theory that a lower level need had to be somewhat satisfied before a higher level of need emerged.

In this study, we measured most of Maslow's needs adapting a scale from Taormina and Gao [28]. A shortened version was created to streamline the data collection process. Some items listed were repetitive and were synthesized into one item. Each dimension was presented as 12 items in their paper, however, after careful evaluation, we ended up using a 9-item scale for personal needs, an 11 for safety, a 10 for esteem, and kept all 12 items in the self-actualization subscale.

Belongingness was adapted from the general Belongingness scale [19]. The belongingness scale in Taormina and Gao [28] was specifically targeted at family, friends, colleagues, and associates. We choose to measure a general belonging scale that specifically measured how included one feels in general. There were 12 items ranging from acceptance or inclusion to rejection or exclusion. Sample items include "When I am with other people, I feel included" or "I feel like an outsider."

We measured Grit from a well-cited scale developed from Duckworth [11]. There were 12 items ranging from consistency of interests or perseverance of effort. Example items include "I often set a goal but later choose to pursue a different one" or "I overcome setbacks to conquer an important challenge." All of our constructs in the research model were measured on a 5-point Likert scale ranging from strongly disagree (1) to strongly agree (5).

Finally, we asked questions on a number of Smartphone Apps. These questions specifically targeted the usage of each application.

Table 3 provides the descriptive statistics of our constructs. Ass of our constructs had Cronbach alpha scores above .63, which are considered very good according to Comrey and Lee [4]. Means and standard deviations of all constructs were appropriate and showed variance in the data.



Construct Name	Number of Items	Cronbach's Alpha	Mean	Standard Deviation
Personal Needs	9	.835	3.31	0.7369
Safety Needs	11	.868	3.69	0.6528
Belonging Needs	12	.931	3.80	0.7430
Esteem Needs	10	.940	3.70	0.8089
Self-Actualized Needs	12	.912	3.18	0.7617
Grit	12	.835	3.37	0.5811
Cell Phone Apps	13	.731	3.05	0.7414

## Results

Figure 3 presents the results of our hypotheses. To test each hypothesis, we used a PLS-SEM analysis in R-Studio. We did a number of validity tests, both discriminant and convergent, in evaluating our data and concluded that the items had appropriate loadings and average variances (AVE's). Results provide confirmation to all of our hypotheses, with the exception of H1d which suggested that Logistical Apps affect one's ability to be self-actualized.

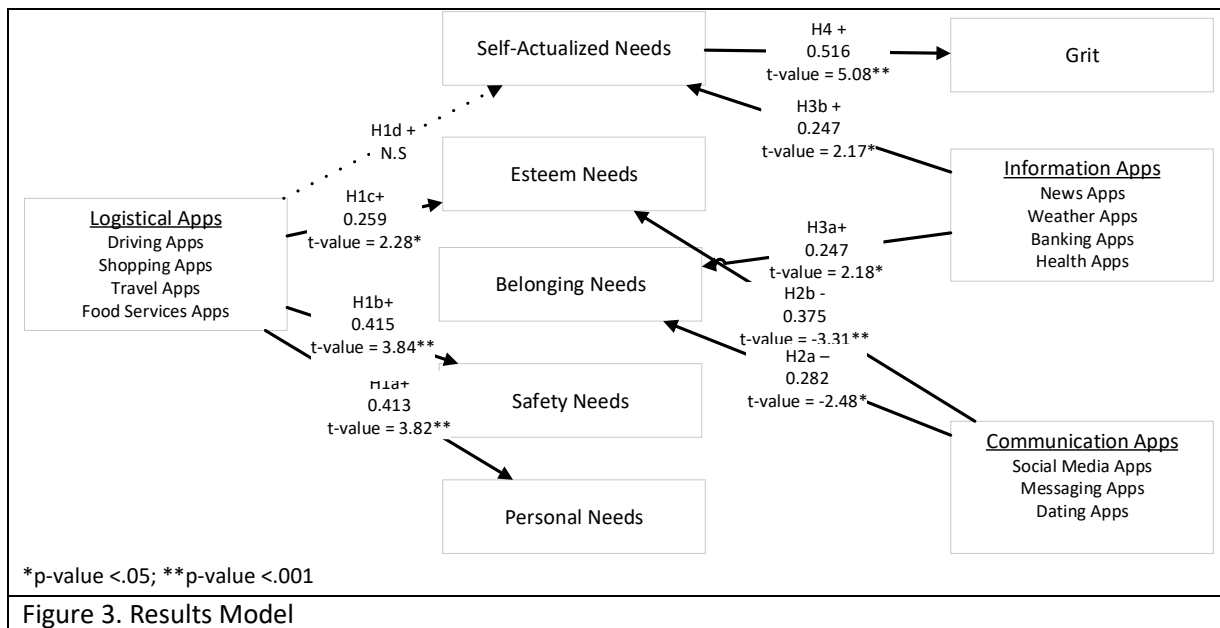

The first grouping of hypotheses suggested that Logistical Apps help satisfy all of one's main needs except belonging. Specifically, Logistical Apps help one satisfy their personal needs (H1a  $\beta$ : 0.413; t-statistic: 3.82; p-value <.01), safety needs (H1b  $\beta$ : 0.415; t-statistic: 3.84; p-value <.01), and esteem needs (H1c  $\beta$ : 0.259; t-statistic: 2.28; p-value <.05). H1d again was not significant suggesting that Logistical Apps do not help one become self-actualized.

The second grouping of hypotheses targeted Communication Apps and suggested they negatively affect one's social needs. Communication Apps hurt one's ability to satisfy their

belonging needs (H2a  $\beta$ : -0.282; t-statistic: -2.48; p-value <.05) and their esteem needs (H2b  $\beta$ : -0.375; t-statistic: -3.31; p-value <.05).

The third grouping of hypotheses suggested that Information Apps help satisfy one's higher order needs, belonging and self-actualized. Information Apps did help one satisfy their general belonging (H3a  $\beta$ : 0.247; t-statistic: 2.18; p-value <.05) and self-actualization (H3a  $\beta$ : 0.247; t-statistic: 2.17; p-value <.05).

Finally, self-actualization was the only variable that helped one be resilient as measured through grit (H4  $\beta$ : 0.516; t-statistic: 5.08; p-value <.01).

### CONCLUSION

Overall, we found that applications are useful in facilitating the ability for individuals to meet certain needs, while other applications may hinder our ability to meet our social needs (belongingness and esteem). Specifically, Logistical Apps are necessary to help us alleviate some of the pressure from needing to keep up with more. They can help facilitate satisfaction with needs at many stages of the hierarchy. On the opposite side, Communication Apps are not helping people reach their higher order needs. Instead, they are actually hurting their ability to satisfy their needs. Information Apps can actually help one find belonging, most likely because getting information and being intrigued in finance, health, weather, and news can make people feel more included. Information Apps also helped facilitate being self-actualized, suggesting that getting information, even from applications like news Apps, can help students grow and become self-actualized. Finally, we found that grit can be developed after feeling self-actualized. This study has implications for researchers and directions for future research, which will be presented at the conference.

### REFERENCES

- [1] Alderfer, C.P., *Existence, relatedness, and growth; human needs in organizational settings*. 1972, New York: Free Press.
- [2] Benetti, C. and N. Kambouropoulos, *Affect-regulated indirect effects of trait anxiety and trait resilience on self-esteem*. *Personality and Individual Differences*, 2006. 41(2): 341-352.
- [3] Cao, H., *A Maslow's hierarchy of needs analysis of social networking services continuance*. *Journal of Service Management*, 2013. 24(2): 170-190.
- [4] Comrey, A.L. and H.B. Lee, *A First Course in Factor Analysis*. 1992, Erlbaum, Hillsdale, NJ.
- [5] Costello, S. *How Many Apps Are in the App Store?* 2019 [cited 2019 October 22, 2019]; Available from: <https://www.lifewire.com/how-many-Apps-in-app-store-2000252>.
- [6] Credé, M., M.C. Tynan, and P.D. Harms, *Much ado about grit: A meta-analytic synthesis of the grit literature*. *Journal of Personality and Social Psychology*, 2017. 113(3): 492-511.
- [7] Davis-Sharts, J., *An empirical test of Maslow's theory of need hierarchy using hologeistic comparison by statistical sampling*. *Advances in Nursing Science*, 1986. 9(1): 58-72.
- [8] Deb, S., *Information Technology, Its Impact on Society and Its Future*. *Advances in Computing*, 2014. 4(1): 25-29.
- [9] Donnelly, L. *Facebook and Twitter feed anxiety, study finds*. 2012 10/24/2019]; Available from: <https://www.telegraph.co.uk/technology/9383609/Facebook-and-Twitter-feed-anxiety-study-finds.html>.

- [10] Duckworth, A. *Why millennials struggle for success*. 2016 October 29, 2019]; Available from: <https://www.cnn.com/2016/05/03/opinions/grit-is-a-gift-of-age-duckworth/index.html>.
- [11] Duckworth, A.L., et al., *Grit: perseverance and passion for long-term goals*. J Pers Soc Psychol, 2007. 92(6): 1087-101.
- [12] Eckerman, A.C., *A new look at need theory. An extension of Maslow's hierarchy*. Training and Development Journal, 1968. 22(11): 18-22.
- [13] Ellison, N.B., C. Steinfield, and C. Lampe, *The Benefits of Facebook "Friends:" Social Capital and College Students' Use of Online Social Network Sites*. Journal of Computer-Mediated Communication, 2007. 12(4): 1143-1168.
- [14] Iqbal, M. *App Download and Usage Statistics (2019)*. 2019 October 22, 2019]; Available from: <https://www.businessofApps.com/data/app-statistics/>.
- [15] Kaufman, S.B., *Self-Actualizing People in the 21st Century: Integration With Contemporary Theory and Research on Personality and Well-Being*. Journal of Humanistic Psychology, 2018: 0022167818809187.
- [16] Kenrick, D.T., et al., *Renovating the Pyramid of Needs: Contemporary Extensions Built Upon Ancient Foundations*. Perspectives on psychological science : a journal of the Association for Psychological Science, 2010. 5(3): 292-314.
- [17] Kross, E., et al., *Facebook Use Predicts Declines in Subjective Well-Being in Young Adults*. PLOS ONE, 2013. 8(8): e69841.
- [18] Lester, D., *Maslow's hierarchy of needs and personality*. Personality and Individual Differences, 1990. 11(11): 1187-1188.
- [19] Malone, G.P., D.R. Pillow, and A. Osman, *The General Belongingness Scale (GBS): Assessing achieved belongingness*. Personality and Individual Differences, 2012. 52(3): 311-316.
- [20] Maslow, A.H., *Motivation and Personality*. 2nd ed. 1970: New York: Harper & Row.
- [21] Maslow, A.H., *Religions, values and peak experiences*. 1966, New York: Penguin.
- [22] Maslow, A.H., *A theory of human motivation*. Psychological Review, 1943. 50(4): 370-396.
- [23] Mokhtarian, P., I. Salomon, and M. Singer, *What Moves Us? An Interdisciplinary Exploration of Reasons for Traveling*. Transport Reviews, 2015. 35.
- [24] Nelson, R. *The Top Mobile Apps, Games, and Publishers of 2018: Sensor Tower's Data Digest*. 2019 October 22, 2019]; Available from: <https://sensortower.com/blog/top-Apps-games-publishers-2018>.
- [25] Rouse, K.A.G., *Beyond Maslow's hierarchy of needs what do people strive for?* Performance Improvement, 2004. 43(10): 27-31.
- [26] Ruiz, R. *Young people feel conflicted about the internet and their well-being*. 2019 10/25/2019]; Available from: <https://mashable.com/article/internet-use-mental-health-youth-survey/>.
- [27] Strong, L.L. and M.S. Fiebert, *Using paired comparisons to assess Maslow's hierarchy of needs*. Perceptual and Motor Skills, 1987. 64(2): 492-494.
- [28] Taormina, R.J. and J.H. Gao, *Maslow and the motivation hierarchy: measuring satisfaction of the needs*. Am J Psychol, 2013. 126(2): 155-77.
- [29] Tay, L. and E. Diener, *Needs and subjective well-being around the world*. Journal of Personality and Social Psychology, 2011. 101(2): 354-365.
- [30] Thielke, S., et al., *Maslow's Hierarchy of Human Needs and the Adoption of Health-Related Technologies for Older Adults*. Ageing International, 2012. 37(4): 470-488.
- [31] Tobin, S.J., et al., *Threats to belonging on Facebook: lurking and ostracism*. Social Influence, 2015. 10(1): 31-42.
- [32] Wahba, M.A. and L.G. Bridwell, *Maslow reconsidered: A review of research on the need hierarchy theory*. Organizational Behavior & Human Performance, 1976. 15(2): 212-240.
- [33] Williams, K.D., C.K.T. Cheung, and W. Choi, (2000) *Cyberostracism: Effects of being ignored over the Internet*. American Psychological Association. p. 748-762.

# **Motivating Knowledge Sharing in Enterprise Social Media: Impact of Avid and Impressionable Learners**

## **Abstract**

This paper studies the use of enterprise social media (ESM) in facilitating knowledge sharing in organizations. Focusing on two types of learners (*avid* or *impressionable*), we explore how they influence the design of reward systems that motivate workers to share knowledge. This research provides valuable insights for practitioners to implement appropriate reward systems to promote knowledge sharing and learning in ESM.

The digital economy has posed new challenges and opportunities for companies to seek innovative ways to organize and manage their knowledge assets. Enterprise social media (ESM), such as Chatter, Connections, Convo, Jive, Kaltura, SociatCast, Socialtext, Tibbr, Workplace, Yammer, and Zyncro, is a specialized online social media platform in organizations that allows employees to form online communities and streamlines connections across different functional departments (Fee, 2013).

One of ESM's main applications includes knowledge sharing and learning; the success of such applications depends on many different technological, organizational, social, and individual factors (Chin et al., 2015). Many of these factors have been identified and discussed in the literature (e.g, Kwahk & Park, 2016; Oostervink et al., 2016). However, very few studies have explored the impact of the learners' types on knowledge sharing and learning in ESM, which is the focus of our research. Specifically, we develop and investigate an analytical model to study how two types of learners (*avid* and *impressionable*) affect the design of reward systems to motivate knowledge sharing in ESM.

We consider the ESM used by a firm to facilitate knowledge sharing and learning among  $N$  knowledge workers. The firm announces a reward to motivate knowledge sharing. Observing the reward policy, workers share knowledge and learn through the ESM accordingly. Then, they apply their knowledge in their work to derive benefits for the firm. Finally, the firm allocates the sharing rewards to knowledge providers based on the pre-announced reward policy.

The ESM is modeled as a network with nodes and arcs in which nodes represent the workers and arcs represent connections between individual workers. We assume that there are many categories of knowledge being shared and learned in the ESM. For a specific category of knowledge, a knowledge worker in the ESM will have either high- or low-knowledge. We permit

a worker to possess high-knowledge for some categories, but low-knowledge for others. In the ESM, when a high-knowledge worker shares knowledge, all of her followers will receive the notification. In order to describe how the followers may react to such a message, we extend a model of ESM similar to the one proposed in Sundaresan and Zhang (2018) and differentiate two types of learners in this research: *avid* vs. *impressionable* learners.

Avid learners will access the message to review the knowledge shared with them in the ESM. Being the most active participants in the social network, they tend to grasp every opportunity to absorb new information and knowledge available to them. In contrast, an impressionable learner may disregard the message that informs her of the new knowledge being shared, especially if the knowledge is not of interest to them. However, when they receive more notifications, they are more likely to read it. After a learner (either avid or impressionable) reviews the knowledge shared with her, she will make a rational and pragmatic learning decision by evaluating its usefulness against the potential learning cost. If she learns the knowledge, she becomes a high-knowledge worker in the category.

Based on such a setting, we develop an analytic model and investigate how best a firm should design a reward policy to motivate high-knowledge workers to share their knowledge, while considering the impact of different types of learners in the ESM. Our research will provide valuable insights for practitioners to implement appropriate reward systems to promote knowledge sharing and learning in ESM.

## Reference

- Chin, C. P. Y., Evans, N., & Choo, K. K. R. (2015). Exploring factors influencing the use of enterprise social networks in multinational professional service firms. *Journal of Organizational Computing and Electronic Commerce*, 25(3), 289-315.
- Fee, J. (2013). 10 Enterprise Networks to Improve Company Communication. Available at <http://mashable.com/2013/06/14/enterprise-social-networks/#IFYKpJgl9qq9>
- Kwahk, K. Y., & Park, D. H. (2016). The effects of network sharing on knowledge-sharing activities and job performance in enterprise social media environments. *Computers in Human Behavior*, 55, 826-839.
- Oostervink, N., Agterberg, M., & Huysman, M. (2016). Knowledge sharing on enterprise social media: Practices to cope with institutional complexity. *Journal of Computer-Mediated Communication*, 21(2), 156-176.
- Sundaresan, S. & Zhang, Z. (2018). Incentive Policies for Facilitating Knowledge Sharing in an Enterprise Social Network. *Journal of Information Technology Theory and Application*, 19(2), 31-56.

## **THE IMPACT OF TECHNOLOGY, BIG DATA, AND ANALYTICS – THE EVOLVING DATA-DRIVEN MODEL OF INNOVATION IN FINANCE INDUSTRY**

Rashmi Malhotra, Haub School of Business, Saint Joseph's University, 5600 City Avenue, Philadelphia, PA 19131, 610-660-3497, rmalhotr@sju.edu

D.K. Malhotra, School of Business Administration, Thomas Jefferson University, School House Lane & Henry Avenue, Philadelphia, PA 19144, 215-951-2813, Davinder.Malhotra@Jefferson.edu

### **ABSTRACT**

The emergence of a digitally driven way of life in this century is driving the global economy in many ways, thereby forcing all businesses to rethink the way they operate and make decisions. The financial sector is also feeling the impact of these disruptive forces. This study examines different factors that are pressuring the financial institutions to rethink the way they do business. Further, we also present the evolving, data-centric and analytics-drive, business model of the finance sector to survive and compete in today's dynamic and digital global market place.

### **INTRODUCTION**

The digital era, the major driving impetus of this century, is having a major impact on the finance industry. The financial institutions are facing tremendous pressure on many fronts such as customer data management, capacity utilization, risk measures, market expectations, and operational efficiencies. Technological advances in computer processing and ever decreasing cost of storing data, coupled with explosion of mobile devices and cloud computing is minimizing the cost of managing data as well as enabling the process of drawing intelligent conclusions from these vast data sources. In addition, the explosion of social media and new regulations around the globe is forcing financial institutions to devise new ways to business. Increasingly, many organizations are realizing the importance of "Big Data" and their role in gaining competitive edge in today's dynamic, digital, and global marketplace. To survive in this new era, financial institutions should move to a new, data-centric way of doing business. These institutions should innovate to leverage big data to improve their operational processes, gain better insight into customers, and explore new market opportunities to continue to be successful. However, transforming big data into actionable opportunities requires the use of sophisticated analytical tools such as advanced machine processing power, data warehouses, and intelligent software. Traditionally, financial institutions devote vast amount of time and resource to draw "structured" data from multiple sources scattered all across the organization, reconcile them into a singular source, and use the data as a resource for decision-making. In addition, the emergence of sophisticated business intelligence and analytical tools is enabling organizations to analyze the vast resources of "Big Data" more efficiently and effectively using far less resources. This study presents the evolving business model of the finance industry. We study the major factors affecting the finance sector. In addition, we also present effective measures that can



enable organizations to survive within the industry. Finally, we summarize and conclude our study and present directions for future growth.

### **WHAT IS BIG DATA?**

One of the biggest challenges financial institutions face is managing huge amount of data in a timely fashion. Big Data refers to management of data beyond the traditional data management techniques businesses use. Big Data encompasses structured, semi-structured, and unstructured information from demographic and psychographic information about consumers to product reviews and commentary: blogs; content on social media sites; and data streamed 24/7 from mobile devices, sensors, and technical devices (PwC, 2013). The ubiquity of the Internet and the World Wide Web as well as explosion of mobile communications and cloud services since 1990s has led to the generation of vast amount of data and information at the disposal of financial institutions to make better decisions. Further, social media or social networking services such as Facebook, Twitter, WhatsApp, SnapChat, or in general, any online messaging system produce extensive amount of human-generated data. This, unstructured and semi-structured data is semantically rich and constitutes 95% of all Big Data (Gandomi and Haider, 2015). Furthermore, we all contribute to this Big Data era proactively through online shopping, email, online communication, and social networking etc. (Sun, Strang, & Firmin, 2017). We characterize Big Data with five main attributes (Kambatla, Kollias, Kumar, & Grama, 2014): volume – order of zettabytes; velocity – high rate of data arrival; variety – diversity of sources; mobility – multiple mobile devices; and detail – qualitative changes.

### **IMPACT OF TECHNOLOGY AND BIG DATA ON FINANCIAL SECTOR**

#### **Shift in the focus of business**

The Financial services organizations are experiencing a shift in the focus as they continue to exploit new opportunities and address new business challenges offered by the perpetually evolving business landscape. Organizations are shifting to a more digital-centric view as technology takes a center seat in the management of an organization and its relationship with all the stakeholders. The technology savvy customer demands large scale technology-driven services and offerings from the financial institutions as opposed to the traditional basic structures. As a result, to remain competitive, financial services organizations are embracing new technology solutions such as web and mobile apps and cloud-based systems leading to a fundamental change in the business processes of these organizations. These organizations have become more customer-centric with more emphasis on customer satisfaction.

#### **Introduction of new technologies**

As technology is changing, many non-traditional financial services such as Venmo and Apple Pay among others are also amongst the competitive forces within the industry. The financial services industry has either adopted or is going through the next digital transformation using

technologies such as artificial intelligence, the Internet of Things and open banking among others. These new digital technologies coupled with the power of big data are the main drivers of the next digital transformation of the financial services industry. Hence, organizations are making the necessary changes to infrastructure and business processes to exploit new technologies. CIOs in the 11 of the 15 industries taking part in a recent Gartner survey ranked digital business/digital transformation as one of their top three business priorities for 2018 and 23 percent of financial services CIOs ranked the transformation as their top most business objective (Goasduff, 2018). The main objective is to generate value for business and stakeholders.

**Hybrid Cloud** - Although, every industry is moving to hybrid cloud, the financial services industry is the frontrunner. According to a report issued by Nutabnix for its Enterprise Cloud Index Report, more than one in five financial organizations polled (21%) are deploying a hybrid cloud model today (higher than the global average of 18.5%). The financial services sector works in a regulatory or compliance driven market. The industry faces external regulatory pressures requiring complete control over data all the way down to the server where the data resides. In addition, financial services companies require the highest level of security, protection, and auditability throughout their enterprise environments (Hernandez, 2018). Furthermore, financial services enterprises want to innovate within their environments and require the ability to develop in open source tools such as Kubernetes, Cloud Foundry, and DevOps toolchains. In addition, the cloud infrastructure should also be flexible enough to accommodate the development needs of many companies and diverse situations. The main benefits of hybrid cloud infrastructure are increased agility, security, and performance using expert analytic tools, cloud-based disaster recovery, and cross-cloud networking tools. Even with an industrywide push, financial services firms struggle with the IT transformation especially over rearchitecting and organizing legacy systems (Bourne, 2019).

**Artificial Intelligence** - The use of artificial intelligence involves using chatbots and intelligent virtual assistants to address customer needs and robotic process automation to improve operational efficiency. For instance, Bank of America deploys intelligent virtual assistant named Erica and Wells Fargo uses chatbots to provide account information or assists customers with changing passwords (Sennaar, 2018). Likewise, Bank of NY Mellon is exploring robotic process automation that combines bots with artificial intelligence to process automated tasks such as fulfilling data requests from external auditors and correcting formatting and data mistakes in funds transfer requests (Sennaar, 2018). Furthermore, the use of machine learning, predictive behavioral analytics, and data-driven marketing can further streamline financial decisions by effectively eliminating the “guesstimation” component. “Learning apps” will not only learn the habits of users, often hidden from themselves, but will engage users in learning games to make their automatic, unconscious spending and saving decisions better (Kagan, 2018).

**Blockchain** - Another popular technology, blockchain is poised to go mainstream in financial services as organizations recognize its potential in reducing fraud. Further, blockchain can reduce payment processing time for cross-border transactions to minutes from the industry

standard of three to six days. In addition, blockchain has potential to improve transaction processing across the board for processes ranging from tracking derivative commodities to mortgage loan processing at a speed unmatched by traditional processes that is more secure and convenient (Comcast Business, 2018). Blockchain uses a distributed ledger (a type of replicated database) that is synchronized for all participating networked members. The technology represents a way to record the ongoing transactions such as exchange of data assets among the members. There is no third party (financial institution, middle man, or any intermediary) as all users follow the accepted rules to update ledger records. Further, once a blockchain is created, all the validated and confirmed transactions or blocks are linked into a chain. The blockchain technology records all transactions sequentially as a chain of blocks with hash links, hence the name blockchain. The blockchain is a single source of transaction history that keeps track of all transactions in a particular chain. Furthermore, member nodes can access the entire history of operations and the recorded transactions (public or private). Thus, blockchain is a new way of safely recording all transactions. In addition, the use of blockchain has also led to the development of cryptocurrencies.

Cryptocurrency - Partially in response to the 2008 financial collapse, Satoshi Nakamoto created Bitcoin in 2009 using a pure peer-to-peer financial system without any intervention from third-party institutions to make transactions. This idea has given rise to many upcoming cryptocurrencies, a new generation of Internet-based currencies that are becoming increasingly popular. Cryptocurrencies are digital currencies that use encryption techniques to regulate the generations of units of currency and verify the transfer of funds (Damak, 2019). These cryptocurrencies (that do not exist physically but can be traded online) are having a profound impact on the financial services industry. For instance, Ripple has developed the Ripple Transaction Protocol (RTXP) network of financial institutions on the blockchain. A company can use RTXP to transact with any other participant at a fraction of the time and cost involved using a traditional system that can be most efficient for global payments. Likewise, Stellar (a Ripple team member) is also having a path breaking impact on the financial industry. They are also collaborating with IBM to facilitate cross-world payments using token economics. Although Bitcoin, Dash, and Litecoin are the lead players in this field, we also have upcoming players such as Nano and Request Network. Nano uses a directed acyclic graph algorithm instead of a typical blockchain. Request Network has built a paypal-like blockchain to expand beyond simple peer-to-peer network without involving intermediaries. As a result, the unbanked can easily avail these affordable banking services using cryptocurrencies. For instance, financial institutions can offer low-cost accounts and loans with more favorable interest rates in developing countries and thus, stimulating the country's economy.

Internet of Things - The Internet of Things (IoT), with supreme power of connectivity and ability to share information, also has potential to streamline operations, especially in the area of banking. The banking sector can use this technology in many ways to improve customer interactions and reduce fraud. Using IoT, banks can use a card's geolocation information to ensure that the card is being used by the cardholder and not a hacker. Banks can also equip a card with biometric sensor to avoid fraudulent use. Further, banks can offer personalized service beginning with the time customer walks in the building, address the customer by name, and make offers based on the customer's past transactional history.

## **Open Banking**

Open banking is a system that provides a user with a network of financial institutions' data through the use of application programming interfaces (APIs) (Frankenfield, 2019). The Open Banking Standard govern the creation, sharing, and access of financial data. Open banking relies on networks as opposed to centralization enabling financial services customers to securely share their financial data with other financial institutions. Thus, customers experience a superior banking experience while transferring funds or comparing product offerings in a cost-effective manner. Open banking is a major innovation in the banking industry with a far-reaching impact on modern banking practices. The APIs facilitate consumers in switching banks, identifying best financial products and services, and getting a better picture of finances. In addition, the use of networked accounts also enable lenders to assess a consumer's financial status and associated risk more accurately to appropriate better loan terms. As a result, open banking challenges traditional banks to be more competitive by adopting new technology and modifying their current business processes. Traditional financial service organizations are trying to catch up with fintech. They will have to adopt an out of the box approach using third-party systems that connect their systems through APIs. With ongoing digital transformation, financial services organizations should adopt a platform-based approach that can improve agility.

## **Alternative Lenders**

Traditional banks and other legacy financial institutions, especially after the 2008 financial crisis, are not fully equipped to identify credit-challenged customers. Thus, to address these concerns, alternative and non-traditional lenders are utilizing technology-based algorithms to assess the credit profile of customers. These alternative lenders use new methods such as machine learning technologies to analyze "alternative data" such as social media, GPS data, online purchase, and mobile data among others. Typically, small businesses are using third-party lenders for their loans. The online lenders use multiple ways to determine the credit-worthiness of a business. For instance, if a business is an Amazon merchant, the online lender can browse through the merchant's customer reviews to learn more about the business. Likewise, other Internet sites such as Yelp, Angie's list, Google reviews, etc. can also provide a better picture of the business. On the other hand, small business can also do online comparison shopping to get the online lender with lowest rate. As a result, traditional financial organizations are facing increased competition from the alternative lenders. Banks and financial institutions are rethinking their strategy to stay competitive. Instead of developing their own technology in-house, traditional financial organizations are partnering with tech companies to enhance their loan approval process and upgrade other service offerings (Hughes, 2018).

## **Digital-Only Banks**

Traditional financial institutions are also facing competition from digital-only banks such as Ally and HelloBank. A digital-only bank (DoB) operates purely online to offer banking facilities to the customers exclusively through digital platforms. Thus, customers have a

whole bank available at the touch of a button on a mobile device such as a iPad, tablet, or smartphone. In many cases, we only need an application and few verification documents to open an account at a DoB. DoBs deliver basic banking services in a simplified fashion through electronic documentation, real-time data, and automated processes. As consumers (especially Millennial Generation) become more dependent on smartphones, DoBs emerge as an influential choice for the smartphone-habituated individuals. Digital-only banks major building blocks are real-time data analysis, Agile-based technologies, and ongoing innovation that differentiate them from the traditional banks (Aggarwal & Varghese, 2019). Real-time data analytics play an important role in the functioning of DoBs. The society's increased dependence on smartphones and data are driving DoBs to leverage "real-time intelligence" to provide personalized customer information such as spending alerts and geo-targeted deals. For instance, a banking app can forewarn customers regarding their monthly budgetary restrictions as well as and notifications of deviations such as certain purchases or a spending pattern that is outside the budgetary constraints. Thus, a customer receives a banking experience that goes beyond the traditional banking services. The DoBs offer speedy transaction processing, cost-effective fee structure, convenience of mobile banking, and a unique personalized experience.

### **Disruption – Fintech's New Mantra**

The most profound effect of fintech innovation on traditional banking, financial advice, services, and products is "disruption." Fintech has expanded the horizons of the financial services industry. The financial products and services were typically delivered by branches and salesmen of large entrenched institutions and knowhow resided on their desktops. However, these financial services and products have migrated to mobile devices or simply democratize away from large, entrenched institutions (Kagan, 2018).

Technology has always been the major driver of financial services landscape and continues to witness many innovative service providers to many verticals under the industry's purview. Further, financial services industry's role is even more enhanced with customers spread all across the globe. However, global presence also poses many risks such as fraud prevention, scalability, integrity, and information security. In addition, the digital footprint of monetary transactions can also serve as a major catalyst for the sector to undertake comprehensive analytics studies. As a result, there has been a rise in financial services technology solution providers such as Automated Financial Systems, Inc., Autoscribe, Blackline, Broadridge, Caco, Demandbase, DST Systems, Duco, FIS, Global Wave Group, Jumino, MISYS, Pendo Systems, Scivantage, SmartStream Technologies, Spigit, Temenos, TRG, Wolters Kluwer and Workiva to name a few. Likewise, cryptocurrencies and blockchain technologies enable financial industry to wield monetary control. Further, blockchain technology also eliminates the need for middlemen in transactions. Thus, the FinTech sector has further expanded with the rise of companies having expertise in assisting the FinTech sector.

## **EVOLVING BUSINESS MODEL**

Figure 1 displays the evolving business model for the financial sector. The information technology infrastructure is the backbone of any organization in this digital era, and financial sector is no exception. The flesh and blood of any organization is the analytical engine and the accompanying data and information resources. The IT infrastructure powers the next level, the analytical engine. Thus, for an organization to survive in the financial industry, the firm should invest heavily in a supporting analytical engine that includes cloud services, database management, knowledge management, and artificial intelligence and other machine learning tools that have the capability to analyze the information resources of the organization. According to the Nutanix survey, financial services firms run more traditional data centers than other industries, with 46% penetration, as well as lower average usage of private clouds, 29% compared to 33% overall adoption of hybrid cloud. Thus, the infrastructure should also be connected to hybrid cloud infrastructure. Furthermore, driven by a need for high data sensitivity, complete control over data, and external regulatory pressures, the industry should follow the private cloud model. Moreover, to innovate, financial services enterprises also manage their own environments using open source tools. In addition, the cloud infrastructure should be flexible enough to accommodate needs of many countries and diverse situations. These information resources can be internal, generated from within the organization such as transactional data and unstructured/ semi-structured data. In addition, an organization also uses external data such as competition intelligence and other market data. Further, financial sector should invest in business intelligence tools that work using the underlying analytical engine. The business intelligence tools enable financial institutions to innovate, establish competitive advantage, develop new products, assess risks, and explore opportunities. The analytics engine is the brain of these smart systems that thinks using advanced AI techniques. Furthermore, the analytical engine is deeply interfaced with Data warehouses and data lakes that can easily acquire data from many disparate sources. The objective is to use an analysis of both structured and unstructured data. Thus, business analytics plays an important role in the development of many Big Data-driven tools. One of the most important function of these tools is to manage customer relationships. Traditionally, IT infrastructure is an important component of the overall management strategy of the organization. However, financial institutions should further expand their IT strategy to develop the analytical engine and the pertinent business intelligence tools. Many organizations recognize the importance of Big Data and business analytics. However, overall, some institutions have concerns that are holding them back from realizing the full potential of Big Data tools and technologies. Businesses can gain important insights into business using Big Data and analytics. In addition, some organizations want to develop a new technological infrastructure that can power the entire financial sector as opposed to the traditional financial structures. For instance, Wanchain is in the process of building a blockchain-based ecosystem using modern technology that will allow anyone to build their financial services using the platform. Wanchain is developing everything from scratch as opposed to fitting into the current infrastructure. They hope to convert physical banks to decentralized apps (dapps) on the block chain.

Figure 2 displays the competitive analysis of the financial services industry using the Porter's model. Traditionally, we perceive financial institutions as entities that initiate and manage transactions from end to end. As shown in the diagram, the traditional business partners are B2B offerings. The main objective of the financial services sector is management of money

comprising of banks, credit and lending companies, insurance companies, and support services and technology. In addition, the industry has individual customers and small business customers. As the financial institutions are adjusting their business models the post-crisis regulatory frameworks, the most creative competitive force impacting the financial services industry is the accelerating pace of technological change. The technological advances is the major driving force enabling new entrants, improving the bargaining power of buyers and suppliers, and development of substitutional services. The new entrants are mostly the FinTech disruptors, usually start-ups that focus specifically on an innovative technology or process ranging from mobile payments to insurance. These disruptors are attacking some of the most profitable elements of the financial services value chain. The incumbents of the financial services industry that historically subsidize important but less profitable service offerings have received a major blow. (PwC paper – technology and beyond 2020). In a survey by PwC Global FinTech, industry respondents indicated that a quarter of their business, or more, could be at risk of being lost to standalone FinTech companies with five years. (PWC Global FinTech Survey 2016). Typically, successful disruptors offer a better customer experience and greater convenience at a much lower price. The effects of disruptors vary significantly across countries and value chains mainly owing to differences in regulatory barriers and the robustness of local FinTech ecosystems. However, even with regulatory and other potential barriers to entry, the FinTech-related services are thriving. Areas such as consumer banking and wealth management are experiencing great demand of these services. Further, as explained above, new technological solutions using artificial intelligence and analytics offer new opportunities to both traditional and new market entrants. For instance, both online-only and traditional wealth management companies use ‘robo-investing platforms’. Further, many new entrants are pursuing a focused differentiation strategy using the online-only model to reach millennials and other segments. In addition, a modern technology-based approach is also an enabler for a low cost strategy. Automation and analytics is also enabling financial institutions as well as customers (commercial and individual) to wield their bargaining power. Furthermore, technology is also substantially reducing the switching cost for commercial and individual customers. Consumers can easily compare the financial service providers through digital means and the cost of switching is just one-click away.

The financial services industry is experiencing many competitive forces with far reaching implications. The introduction of BlockChain using a shared transaction ledger is expected to be a positive disruption force in the industry. The BlockChain technology presents an opportunity for financial institutions to cut costs by streamlining back-office operations, shortening clearing and settlement times, facilitating payments, and generating new revenue streams. The industry can use Blockchain to offer banking services such as bank payments, trade finance, money transfer, and post-trade services. Further, having a real-time standardized view of transaction data without needing to conduct multiple reconciliations would remove the inefficiencies hindering the financial systems and reduce costs. Another major development impacting the industry is the use of digital currency. Digital currency poses a serious threat to the traditional money system established by banks to date. Cryptocurrency is brand new concept that uses an unhackable technology (encryption) and does not require any involvement from banks or state. Traditionally, the value of money largely depends on the credibility of the state and banks manage the quantity and price of the

currency. Cryptocurrency is challenging the traditional banking system and the current way of managing currency. As everything around us gets digitized and technology becomes the major driving force as way of life, cryptocurrency can turn main stream. Traditionally, we are used to keeping our money in a bank and pay a certain fee for some services. However, cryptocurrency can be used as a digital equivalent of money that we can keep in a form of cloud and operate from home while incurring a very low fee. Despite the fact that people cannot see digital currency, the digital currencies are slowly gaining legitimacy. Being around for almost 10 years, the demand for cryptocurrency is slowly increasing. Further, cryptocurrency is a completely independent currency that offers total security to its users. The encryption technology ensures that none can have unauthorized access to a user's personal information. Furthermore, the system charges significantly lower fee than any bank while offering a same or higher level of security especially for international payments. Thus, cryptocurrency have a potential to improve the global economy. In addition, the use of digital currency empowers people as opposed to governments and financial institutions. However, the financial services industry is still in a transition stage. The regulatory authorities are facing the daunting task of offering a meaningful oversight of FinTech disruptors without stifling competition and innovation. The state authorities want to ensure that people are using this innovative system legally and responsibly.

### **NEW MEASURES**

The financial firms have varied perception of Big Data. Financial institutions often mistakenly view Big Data as primarily being a technology challenge rather than a business opportunity. In reality, data is created by the business, owned by the business, and used by the business. As the custodian of Big Data, IT is still in the process of figuring out how to gain the buy-in of their business leaders. Virtually every industry is moving to hybrid cloud, but financial services industry is the leader in adopting this technology. Faced with increased competitive pressure, higher security risks, and new regulations, the financial services industry should modernize its IT infrastructure. The new up-to-date tools such as expert analytical tools, cloud-based disaster recovery, and cross-cloud networking tools are the main drivers of performance, availability, and security. Traditionally, we perceive financial institutions as business entities that initiate and manage transactions from end to end by placing their own capital at risk. In future, financial institutions would play an intermediary role with lower stake, or will be one of the participant in the value web. Enabled by partnerships with FinTech companies, financial services industry will eventually be driven by peer-to-peer transactions. In the 90s, the financial services industry adopted the e-business model to benefit from e-commerce. Eventually, the new technology-driven model being more efficient became the industry standard with 'e' simply vanishing. Likewise, we are again at the helms of new technology innovation driven by the digital wave. This digital agenda encapsulates customer experience, operational efficiency, big data, analytics, artificial intelligence, and robotics.

### **SUMMARY AND CONCLUSION**

Fintech, a portmanteau of 'financial technology' refers to application of the latest technology and business intelligence and analytics to improve and automate the delivery and use of



financial services. The objective of fintech is to enable organizations and their stakeholders improve operations and accompanying-processes through the use of specialized software and algorithms residing on any computing device including tablets and smartphones. Hence, fintech also includes the use of a suitable IT infrastructure that supports different platforms including mobile computing. At the onset, financial institutions used fintech to refer to back-end systems. However, as the financial services sector experienced a shift in business to more consumer-oriented services, the industry needs have also changed. Fintech has expanded to become an umbrella term that encompasses any technological innovation pertaining to the financial sector. This includes automation of the financial sector as well as advances in financial literacy and education. Technological innovation also involves streamlining of wealth management, lending and borrowing, retail banking, fundraising, money transfer/payments, and investment management. The financial institutions are way past the stage of questioning the need of Big Data and business analytics. Blockchain technology is in the process of changing the financial industry. The use of cryptocurrencies enable financial institutions to gain a secure store of value, peer-to-peer payments without any intermediaries, and complete monetary control. Further, besides digital transactions, many new crypto projects are targeting the unbanked, making blockchain technology more scalable, and providing flexible interfaces. With advances in technology, a new supporting technology infrastructure might develop.

#### **REFERENCES & FIGURES**

References and Figures are available upon request.

## **USABILITY COMPARISON STUDY BETWEEN E-COMMERCE AND V-COMMERCE**

Nick Jones, College of Business, University of West Florida, 11000 University Parkway,  
Pensacola, FL 32514, naj13@students.uwf.edu

Philip Billings, College of Business, University of West Florida, 11000 University Parkway,  
Pensacola, FL 32514, peb7@students.uwf.edu

June Wei, College of Business, University of West Florida, 11000 University Parkway,  
Pensacola, FL 32514, 850-474-2771, jwei@uwf.edu

### **ABSTRACT**

This paper aims to determine the differences in preference in regards to usability of Electronic Commerce (E-Commerce) and Virtual Commerce (V-Commerce). To assess user preferences on usability, a virtual commerce shopping website was developed first, and then a survey was created with a total of fifteen items to measure. Data was collected by asking subjects to first browse the developed virtual commerce shopping website, and then answer the fourteen-item questionnaire. The major findings from the statistical analysis indicates that there are six usability items of V-Commerce elements that are superior to E-Commerce. Moreover, the results also indicate strong feelings differences by using mobile and stationary devices. Furthermore, users are more likely to accept V-Commerce if implemented properly. Some theoretical, managerial and practical implications are also presented.

### **Introduction**

E-Commerce (or electronic commerce), upon introduction, radically changed how consumers purchased items, which lead to a more seamless system that allowed more convenience while shopping online. E-Commerce utilized the internet as a foundation to facilitate an easier method for the retail supply chain to be utilized in a more efficient manner. It is noted that the supply chain, “concerns coordinating the flows of materials, information, services, capital and information...” [1, p. 1126]. If an individual possesses an internet connection and a computing device, he or she can purchase products anywhere. E-Commerce is still evolving today and has been applied to almost every area of physical commerce. What began as 2.59 billion-dollar market has expanded to 18.74 trillion [4]. What began as simple internet shopping has evolved, setting up virtual commerce to be the next generation of electronic commerce. “Physical retailers still see the Web as an arena for marketing and promotion: a new channel for doing old things [6, p.89].” V-Commerce, or virtual commerce, is just now coming into prominence, and could change the way we shop online.

A level of trust is needed for the consumer market to welcome the idea of virtual commerce. “The theory of information richness posits that equivocal interactions, such as ones requiring trust, can be facilitated through communication media that transmit multiple cues interactively” [2, p. 1]. V-Commerce is in its early stages of development, but it has great potential to enhance

the online retail and service industries. V-Commerce allows customers to experience the products they are purchasing in much greater detail, so they know exactly what the item or service is that they are paying for. For example, V-Commerce can be implemented in the current retail industry by utilizing virtual spaces where customers can view virtual models of an item they wish to purchase. Seung-A Annie Jin and Justin Bolebruch [7, p. 5] described the increased immersion users feel in the presence of virtual environments, and provided various calculations based upon user immersion. Virtual environments present “plausible portrayals of the real world inside a virtual world.” Immersion can be accomplished using simple 3D models which the user can interact with and proper viewing devices.

V-Commerce has the potential to allow a company to have an edge over their competitors, but there has been a lack of research into this field. Our study aims at investigating the differences of the usability preferences between V-Commerce and E-Commerce. For the study, the airline industry was chosen due to the many possibilities there are for integrating V-Commerce into the industry. One example would be the use of V-Commerce to map airports when selecting layover airports, which would allow the customer to select the layover of their choice. For the prototype for this study, seat selection was chosen. Currently, seat selection when booking flights usually involves a giant rectangle, representing the plane, filled with many smaller squares representing seats. In the same system, airlines are encouraging customers to upgrade their seats for more legroom, or to even upgrade to premium economy or business classes. The current seat selection systems work for their intended purpose, but they could be greatly improved by integrating V-Commerce. The prototype system developed for this study to allow users to conceptualize the use of V-Commerce featured a cross-section of an airplane system with appropriate seating. In addition, a model of a singular seat was included, to allow users to better-view the seat they wished to purchase.

The following sections of this paper are arranged as follows: Section two presents methodology, Section three data analysis and findings, and Section four discussions, implications and conclusions.

## **Methodology**

### **Survey**

The questionnaire was developed by adopting and modifying the questions from a validated questionnaire found in published literature such as Ozok and Wei [5]. Table 1 presents all items within the survey. The questions were comprised of a ‘likert scale’ structure. This scale introduces a range of answers for each question, ranging from least to most superior. These scales are very useful in gathering information from prospective survey participants on the internet [3]. The scale of the survey is intended to replicate a five-point system, in which it ranges from 1 (E-Commerce much better) to 5 (V-commerce much better). The mid-ranges are 2 (E-Commerce slightly better), 3 (both are about equal), and 4 (V-Commerce slightly better).

**Table 1. Items in the Survey**

Item Number	Items
I1.	Overall shopping convenience
I2	Shopping at any time
I3	Overall interface convenience
I4	Input interface convenience
I5	Keyboard convenience
I6	Cursor movement convenience
I7	Shopping for customized products
I8	Shopping for variety of products
I9	Shopping for variety of content
I10	Shopping for customized services
I11	Shopping international vendors
I12	Customer service after purchase
I13	Seeing pictures of products
I14	Seeing animations of products
I15	Ability to shop customized products

### **Prototyping Development and Data Collection**

A prototype was built to model an airline seating selection system. Currently, there is no airline utilizing V-Commerce in its airline seating selection systems, with most airlines using a simple 2D diagram to allow customers to select their seat. Since airlines currently do not utilize V-Commerce, the industry was selected for the prototype so that users would be able to conceptualize V-Commerce. In addition, explanations were added to inform users what E-Commerce and V-Commerce were if they did not fully understand the concepts.

This prototype was built by using Google Sketchup Pro and creating a virtual reality model of an airplane cabin. This prototype can be adopted in a stationary desktop and a mobile device. We used a convenient sampling method to collect subjects at a major university in the United States. Subjects volunteered to experience a V-Commerce prototype and complete a survey. Subjects were invited to explore this prototype before completing the survey. This way, subjects would have a good understanding of V-Commerce.

### **Data Analysis**

Forty-eight graduate and undergraduate students from a major university participated in this study. Participants were students in either management of information systems, business administration, or honors programs. These participant groups were chosen because of the likelihood that college students would be familiar with the concepts of E-Commerce and V-Commerce, as well as for practicality and convenience. Twenty of the subjects were male

(41.7%) and twenty-eight were female (58.3%). Subjects shopped online an average of 4.46 times in the past month.

**Table 2. Demographical Analysis**

	Subjects
<b>Total number of subjects:</b>	48
<b>Age Range:</b>	
18-20	28
21-29	18
30-59	2
<b>Gender:</b>	
Male	20
Female	28
<b>Education:</b>	
High School	3
Some college:	18
Associates:	14
Bachelor's:	3
Graduate:	1
<b>Number of times subjects shopped online in the past month:</b>	
0 to 1:	8
2 to 3:	18
4 to 5:	12
6 to 9:	4
10 or more:	6
<b>Number of times subjects accessed Internet daily:</b>	
1 to 3	3
4 to 6	4
7 to 9	13
10+	30

All the Cronbach's alphas for these fifteen items show the values greater than 0.75, indicating a good validity.

Table 3 presents the mean and standard deviation based on the collected data. Primary findings from Table 3 are as follows: Items 1 through 5, 8, 9, 11 and 12 had averages of less than three. These averages indicate that E-Commerce is at least slightly better than V-Commerce in accomplishing that item. Item 5, for example, has an average of 2.4 (standard deviation of 1.03); however, item 5 covers keyboard convenience, meaning that E-Commerce is more convenient when using a keyboard, but V-Commerce is less convenient when using a keyboard.

Items 6, 7, 10, 13, 14, and 15 had averages that were 3 or greater. These averages indicate that V-Commerce was at least slightly better in accomplishing those items compared to E-Commerce. Item 15, the ability to shop customized products, had an average of 3.6 (standard deviation of 1.18). Our subjects rated V-Commerce as better for shopping customized products than using E-Commerce. These results indicate that companies, which produce customized products, may want to explore the possibility of integrating V-Commerce, as our subjects rated V-Commerce as being better than E-Commerce in that category of products.

The item with the highest average was item 14, which covers visualizing animations of products, with an average of 4.2 (standard deviation of 1.07). Subjects found V-Commerce to be much better than E-Commerce when displaying animations. The second highest average was item 7 with a mean of 3.6. Item 7 covered shopping for customized products and had a standard deviation of 1.41.

**Table 3. Mean and Standard Deviation**

	Mean:	Standard Deviation:
I1:	2.5	1.03
I2:	2.2	0.98
I3:	2.8	1.17
I4:	2.8	1.12
I5:	2.4	1.03
I6:	3.0	1.26
I7:	3.6	1.41
I8:	2.3	1.31
I9:	2.3	1.24
I10:	3.5	1.30
I11:	2.9	1.18
I12:	2.9	0.97
I13:	3.3	1.37
I14:	4.2	1.07
I15:	3.6	1.18

Furthermore, these subjects were randomly assigned into two groups, one using stationary PCs and the other mobile devices with 24 subjects in each group. The t-test was performed to test the differences between the two groups. The results show that the different preferences exist in Items 1, 5, 7, 8, 9, 10, 13, 14 and 15 between the smartphone user and stationary user groups at 1% significance level.

Further analysis indicates that V-Commerce is more preferred in Items 7, 10, 13, 14 and 15 in both smartphone and stationary user groups, while V-Commerce is less preferred in Items 1, 2, 3, 4, 5, 8, 9, and 11 for both groups. Item 6 shows same preference for the two groups. For Item 11,

the smartphone user group shows no preferences for V-Commerce and E-Commerce, while the stationary user group shows the preference of E-Commerce over V-Commerce.

### **Discussions, Implications, and Conclusions**

In summary, this study compares E-Commerce to V-Commerce in the airline industry. Users viewed a prototype of an airline seating selection system integrated with V-Commerce, then answered a questionnaire by comparing E-Commerce to V-Commerce.

V-Commerce is currently in the early adoption phase, so many users on the Internet still have minimum experience with V-Commerce while shopping. This study shows that V-Commerce is becoming a viable option that companies can begin to explore to market their products, especially companies that utilize animations for their products or have customized products and services. With users currently feeling neutral about the concept of V-Commerce, both positive and negative depending on its implementation, a company must evaluate how it integrates V-Commerce to do in a way that improves the customer experience.

Depending on what environment V-Commerce is contained within, it may have high success in marketing products by utilizing the virtual reality technology to customize products and services. Considering virtual commerce methods can be integrated into existing commerce portals, we might see a switch in favorability soon once virtual commerce becomes further developed.

One limitation of this study is the tasks focusing on airline V-Commerce. Future studies can be conducted in the other V-Commerce tasks. Different online shopping prototypes can be constructed, and further comparison studies can be conducted to compare V-Commerce and E-Commerce usability preferences.

### **REFERENCES**

- [1] Alexandru, C. (2014). An Exploratory Approach to Integration of Business Practices in Supply Chain Management. *Annals of the University of Oradea, Economic Science Series*, 23(1), 1125–1134.
- [2] Chesney, T., Chuah, S.-H., Dobele, A. R., & Hoffmann, R. (2017). Information richness and trust in V-commerce: implications for services marketing. *Journal of Services Marketing*, 31(3), 295–307. <https://doi-org.ezproxy.lib.uwf.edu/10.1108/JSM-02-2015-0099>
- [3] Dillman, D. (2000): *Mail and Internet Surveys: The Tailored Design Method*. John Wiley and Sons, Inc., New York, NY.
- [4] Laudon, C. , Traver, G. (2016). *Ecommerce 2016*. Business, technology, society, 1-40.
- [5] Ozok, A. & Wei, J. (2010), An Empirical Comparison of Consumer Usability Preferences in Online Shopping Using Stationary and Mobile Devices: Results from a College Student Population. *Electronic Commerce Research*. Vol. 10, No. 2, p. 111-137.
- [6] Evans, P. & Wurster, T. (1999). Getting Real About Virtual Commerce. *Harvard business review*, 77(6), 84-94.

- [7] Jin, A, Bolebruch. (2010). Journal of Virtual Worlds Research. Virtual Economies, Virtual Goods and Service Delivery in Virtual Worlds, 2(4), 1-12.



## **WIELDING BLOCKCHAIN TO ENHANCE COUNTERFEIT DRUGS PREVENTION IN PHARMACEUTICAL INDUSTRY: A PRACTITIONERS' PERSPECTIVE**

Chengqi "John" Guo and Ping Wang

College of Business, James Madison University, 421 Bluestone Dr., Harrisonburg, VA 22807

Emails: (Guo) [guocx@jmu.edu](mailto:guocx@jmu.edu) and (Wang) [wangpx@jmu.edu](mailto:wangpx@jmu.edu)

### **ABSTRACT**

In the eyes of supply chain businesses, blockchain shows signs of future success that brings about transparency, integrity, and durability. These are important qualities of effective supply chain management, especially for entities in the healthcare and pharmaceutical industries. Therefore, this paper aims to (1) provides an in-depth view in terms of leveraging blockchain in pharmaceutical supply chain to create safeguarded and verifiable transactions among stakeholders, allowing them to prevent the entry of counterfeit drugs; (2) proposes the use of UTAUT model to reveal practitioners' perceptions regarding the use intention of the distributed ledger technology. Operational and technical insights are provided to explain how blockchain can recalibrate internal processes within the information flow. Key stakeholders and their roles in the deployment of blockchain solutions are identified and characterized. Limitations, concerns, and remedies are also discussed.

**KEYWORDS:** Blockchain, Supply Chain, Pharmaceutical Supply Chain, Healthcare, Technology Adoption, Disruptive Technology

### **INTRODUCTION**

Modern healthcare supply chains are inherently complex, consisting of disjointed entities that follow a specific logic and geographical distribution. There is an added complexity when it comes to international supply chains that involve diverse national cultures, policies, and human behaviors. Inefficient transactions, frauds, and poorly designed logistics engender trust crisis at both organizational and individual levels. Hence, data integrity, traceability, and transparency are becoming increasingly urgent requirements for the next-generation pharmaceutical supply chain management. Although some technologies such as RFID provide a viable avenue, they contain weaknesses that prevent them from serving in full capacity. For example, the electromagnetic signals of RFID are vulnerable to cyber-attacks, including unauthorized access and denial of service. Besides, RFID relies on a central database that, compared to a distributed ledger, is less favorable in terms of data access speed and service availability. There is still a long way to go before blockchain can be holistically implemented in the service industry. The open-source infrastructure and easy-to-implement algorithms of blockchain make it a feasible solution to counterfeit drug problems in the supply chain.

### **LITERATURE REVIEW**

Our literature review consists of three pillars – the status quo of healthcare industry with a focus on counterfeit drug mitigation, idiosyncrasies and benefits of Blockchain technologies that can be associated with the issues confronting healthcare industry entities, and the UTAUT model that evaluate factors influencing Blockchain use intention among practitioners.

## **Healthcare Industry & Counterfeit Drugs**

Having drugs that are made of counterfeit could mean they may contain no active ingredient, the wrong active ingredient or the wrong amount of the correct active ingredient. It is estimated that one in ten medical products in low- and middle-income countries is substandard or falsified [1]. This is a problem which affects the world where both generic and innovator medicines can be falsified, ranging from very expensive products for cancer to low cost products for treatment of pain.

Healthcare industry is no stranger to problems owing to counterfeit drugs, whose definition covers both drugs that are falsified or sub-standardized. These drugs wreak major havocs in three areas: personal health, social impacts, and economic impacts. For personal health, if the drug is meant to be a vaccine but does not contain any or the right amount of ingredients, the patient is exposed to the diseases unprotected. Additionally, the lack of an effective drug to treat diseases or vaccine to prevent diseases, the more percentage a population will be ill with the disease. This not only affects those diseased but also allow the disease to spread further and for a longer period. This could lead to antimicrobial resistance where the drug concentration was not large enough to wipe out all the microbes, leaving some with better resistance to the current drug, which reproduce rapidly with the absence of the non-resistant ones [2]. The observed social impacts correlates with the passive or indirect costs of counterfeit drugs. Firstly, with the use of counterfeit drugs in the area, a patient could be constantly ill, resulting in low productivity or even loss of income if the patient cannot go to work for prolonged periods of time [3]. In some places with inaccessible healthcare, the time and monetary costs of traveling for healthcare could be significant to the patient as well. This could result in a poverty cycle especially if the people in an area are constantly sick, or die, due to counterfeit medication [4].

## **Blockchain as a Solution**

The current tactics to reduce or stop the entry of counterfeit drugs rely on ad hoc transportation control technologies, such as Sproxil and mPedigree. The former has partnerships with drug companies to have scratch-panel stickers covering codes, which are attached to the drug packets. Customers would scratch to reveal the code, which can be verified by sending a text to Sproxil who confirms the authenticity. The latter uses barcodes which can be scanned and compared to the central database using an app rather than codes and text messages [5]. Despite visible effects, these tactics bear significant burdens. For instance, the operational costs drive up the price to a level that forces many clients and customers to pursue more affordable options, which face the same counterfeit problems those technologies address, creating a loop of fallacy.

Blockchain, therefore, emerges as a viable solution that offers a balanced portfolio of cost management and performance. The pharmaceutical supply chain can leverage the Blockchain technology, an encrypted and immutable decentralized ledger, to create a transparent and verifiable database of transactions. Information about drugs and their transactions can be shared with all stakeholders and at the same time ensuring that individual drugs are tracked at each step of the supply chain. The blockchain would record each time a drug swapped hands, assisting companies in detecting tainted products before they reach consumers. This kind of tracking is needed since counterfeit drugs are nearly impossible to detect. Counterfeiters can produce look-

alike drugs and devices that contain little or no active ingredients, or the wrong ingredients, for less than the authentic medication would cost to make [6][7].

Each buyer and seller within the pharmaceutical supply chain will have their own address for transacting the drugs in the supply chain. At the manufacturer level, serial or batch number, quantities and other drug information can be used to generate a hash number which is the public key and using this public key a Quick Response code (QR code) as the drug ID. Doing so will allow only a single transaction happening from one party to another (e.g. from manufacturer to wholesaler). prevents double spending of the drug and by broadcasting the transaction onto the blockchain, it also allows each supply chain stakeholder to instantly track if a suspicious transaction has occurred [8].

The stakeholders in a pharmaceutical supply chain include regulators, manufacturers, wholesalers, pharmacies, hospitals and the end users (e.g. patients). The regulators should take a lead role to oversee the alliance of supply chain stakeholders and issue licenses to the verified stakeholders and give them access to the blockchain network, tools required. The other stakeholders will have the responsibility to ensure that at each step of the drug supply chain, the transactions are digitally signed and therefore broadcasting the transaction onto the blockchain.

Conditions can be set to determine if a drug transaction goes through from one party to another. Only when all the conditions stated in the smart contract are met, the smart contract will be triggered, and the transactions is then executed. In addition, regulators can define certain threshold and risk level on the transaction activities and set these conditions in the smart contract. If a transaction exceeds the risk level, it will not go through and gets rejected. Therefore, the use of smart contracts aims to minimize the amount of effort for surveillance and monitoring of counterfeit drug transactions [9].

## **UTAUT**

### **PROPOSED METHODOLOGY**

### **DISCUSSION & CONCLUSION**

### **REFERENCES**

- [1] World Health Organization. (2017). A study on the public health and socioeconomic impact of substandard and falsified medical products. Geneva: WHO.
- [2] Karunamoorthi K. (2014). The counterfeit anti-malarial is a crime against humanity: a systematic review of the scientific evidence. *Malar J.* 2014;13:209. Published 2014 Jun 2. doi:10.1186/1475-2875-13-209
- [3] Photopoulos, J. (2019). Fighting fake medicines. Retrieved September 6<sup>th</sup> from <https://www.chemistryworld.com/news/fighting-fake-medicines/3010498.article>
- [4] Tseng, J.-H., Liao, Y.-C., Chong, B., & Liao, S. (2018). Governance on the Drug Supply Chain via Gcoin Blockchain. *International Journal of Environmental Research and Public*

- Health*, 15(6), 1055. <https://doi.org/10.3390/ijerph15061055>
- [5] Wall, M. (2016). Counterfeit drugs: “People are dying every day” - BBC News. Retrieved November 10, 2019, from <https://www.bbc.com/news/business-37470667>
- [6] Cottrell, S. (2018). How To Ensure End-To-End Visibility In Pharmaceutical Supply Chains. Retrieved November 10, 2019, from <https://www.pharmaceuticalonline.com/doc/how-to-ensure-end-to-end-visibility-in-pharmaceutical-supply-chains-0001>
- [7] Chong, B., & Shih-wei, L. (2018). Governance on the Drug Supply Chain via Gcoin Blockchain. *International Journal of Environmental Research and Public Health*, 15(6), p. 1055.
- [8] Steve, C. (2018). How To Ensure End-To-End Visibility In Pharmaceutical Supply Chains. Retrieved on October 18<sup>th</sup>, 2019 from <https://www.pharmaceuticalonline.com/doc/how-to-ensure-end-to-end-visibility-in-pharmaceutical-supply-chains-0001>
- [9] Wall, M. (2016). Counterfeit drugs: 'People are dying every day'. Retrieved October 18<sup>th</sup>, 2019 from <https://www.bbc.com/news/business-37470667>

**Management, Strategy,  
Organizational Behavior,  
Organizational Theory,  
and Human Resource  
Management- Abstracts**

# CHILDCARE BENEFITS AS GLOBAL EMPLOYEE RECRUITING AND RETENTION TOOLS

---

Regular Session

---

*Ms . Courtney Strole <sup>1</sup>, Dr . Marko Grunhagen <sup>1</sup>*

*1. Eastern Illinois University*

Globally, it has become increasingly common for employers, both public and private, to offer benefits packages to their full-time employees. Some of the more common types of employer-provided benefits include health insurance, dental, life insurance, and retirement plans. The variety and range of benefits provided can boost an employee's loyalty to a company and reduce absenteeism, in turn reducing turnover and boosting employee morale, product/service quality, overall productivity, and ultimately firm performance. Offering employee benefits may also serve as a recruiting tool to attract new employees vis-à-vis competing employers with lesser benefits.

This research paper contrasts differences in childcare in the five largest global economies (US, China, Japan, Germany, UK) through case studies for each country. In the process, cultural idiosyncracies, such as the value of family as well as the value put on work-life balance in each culture, will be highlighted to provide rationales for the varying childcare benefits offered.

# Diversity training: Is it a goal oriented action or just a business?

---

Regular Session

---

*Dr . Shanggeun Rhee <sup>1</sup>, Ms . Bibi Salaman <sup>1</sup>, Prof . Nesreen El-Rayes <sup>1</sup>*

*1. Kean University*

Companies are spending multi-million dollars a year on diversity training. The budget set for diversity training enforcement, in addition to the professionals hired to provide consultation and handle diversity related issues are increasing year after year.

Many studies confirm that organizations with diverse workforce have better overall performance and results compared to less diverse ones.

But the main challenge is that there are a lot of doubts regarding the application and fostering of diversity within the organizations that invest a lot on the diversity training. The course of actions taken and applied toward diversity within the organizations does not seem to be different compared to the actions taken a decade ago.

Although technology shaped and enhanced the quality and methodology of providing diversity training to cope with the continuous changing needs in the businesses world, still the results are almost negligible. The proportion of people of color in management positions at major US companies is still below 20 % and it gets worse in the C-level managerial positions.

With the proven path to success of diversity and all the efforts put forth by companies, why doesn't that lead to any fruitful success? Are companies using diversity training as a tool to defend or brand for their organization without having any intentions or goals to enforce diversity? Are organizations willing to follow the recommendations by academia about the training methods that are proven to be more effective in increasing diversity? Are current governmental regulations working properly to improve diversity in private sectors?

This study aims to seek an answer for these fundamental questions by looking at many areas of diversity and provide practical solutions.

---

# Examining the Link Between Corporate Political Activity and Firm Performance: A Non-Parametric Analysis

---

Regular Session

---

*Dr . William Kline <sup>1</sup>, Dr . Richard Brown <sup>1</sup>*

*1. PSU - Harrisburg*

While scholars have been examining the CPA to performance linkage, scholars in a host of fields have been developing and utilizing data envelopment analysis (DEA). Despite the sound foundation for DEA logic and applications, as well as a forty-year track record and wide acceptance, the usage of DEA in mainstream management literature remains scarce. Management scholars overwhelmingly utilize regression analysis in their studies, and few rely upon frontier methodologies (Chen, Delmas, and Lieberman, 2015). In a review of more than 50 papers examining the CPA to firm performance link, Liedong (2013) found that the preponderance of studies employed regression analysis with the minority using event study methodology. It is against this backdrop that we incorporate DEA methodology into an analysis of firm-level CPA and performance.

In this paper, we test a series of hypotheses concerning corporate political activity and subsequent performance at the firm level. Using a panel dataset with a sample of S&P 500 firms, we measure the relationships between corporate lobbying and firm performance measured with ROA and ROE in the United States. We expand the current CPA-to-performance knowledge base by utilizing parametric (i.e., regression analysis) and non-parametric (i.e., Data Envelopment Analysis) methods.

Our theoretical contributions in this paper are two-fold. First, we add robustness to the CPA literature and the existing theoretical model linking CPA to firm performance. Our value contribution, particularly with respect to our regression analysis, would be considered incremental, but would be consistent with the normal course of advancement in organizational research.

Second, we contrast multiple methodologies to examine traditional theoretical models. While the CPA literature has grown considerably in recent years, to the best of our knowledge, no scholars have studied CPA with a nonparametric method such as data envelopment analysis (DEA). Our second theoretical contribution stems from this lack of attention. DEA is a frontier-based approach that highlights the most efficient or top-performing firms, while traditional statistical approaches rely on measures of central tendencies (Hansen, Perry, & Reese, 2004). By adding DEA to this line of study, we incorporate an approach that is better aligned with the study of extreme outcomes that are positive in nature (i.e. studies of top performers in industries) (Yip, Devinney, and Johnson, 2009). Interestingly, the comparison of two statistical approaches, lays the foundation for theoretical contributions which are “revelatory insights” (Corley and Gioia, 2011) built on the pillars of scholarly surprise (Mintzberg, 2005) and interest (Davis, 1971), two important ingredients for challenging conventional wisdom.



---

# MEANINGFUL WORK LINKING HIGH-QUALITY RELATIONSHIPS TO COMMITMENT: A CONDITIONAL PROCESS STUDY

---

Regular Session

---

*Dr . Kelly Hall <sup>1</sup>, Dr . Baiyun Gong <sup>2</sup>*

*1. Stetson University , 2. Nova Southeastern University*

Relational coordination manifests in high-quality relationships, which are comprised of shared goals, shared knowledge, and mutual respect (Carmeli & Gittell, 2009). In recent years, scholars have issued calls to examine relational coordination outcomes for both organizations and employees. We respond to this call by applying relational coordination theory (Gittell, 2006) to investigate how high-quality relationships influence meaningful work and, in turn, commitment. Further, we leverage protean career theory (Hall, 1976) to propose a conditional process model in which these effects vary by one's career orientation.

Utilizing a sample of working adults ( $N= 320$ ), we tested the proposed relationships with robust data analytic techniques, and our results were consistent with the hypothesized conceptual theme. Meaningful work serves as a key mechanism in determining the association between high-quality relationships and commitment. Specifically, meaningful work mediated the indirect effect of high-quality relationships on affective commitment. Moreover, we found that protean career orientation acts as a boundary condition, in that as protean career orientation increases, the relationship between meaningful work and affective commitment becomes stronger. As such, our findings reveal a pattern of moderated mediation, which suggests that the connection between high-quality relationships and commitment is complex for those who value self-directedness and define career success according to their personal values.

We discuss the contributions of our work. To this end, we highlight the value of bridging the literature on high-quality relationships with those of meaningful work and commitment. Likewise, we present several implications for practice, for example, the importance of fostering perceptions of shared goals, shared knowledge, and mutual respect, and we propose ways to strengthen such perceptions in the workplace. Finally, we discuss the findings of our research in the context of other interesting directions for future research.

*Keywords: high-quality relationships, meaningful work, commitment, protean career orientation, relational coordination*

## **References**

- Carmeli, A., & Gittell, J. H. (2009). High-quality relationships, psychological safety, and learning from failures in work organizations. *Journal of Organizational Behavior*, 30(6), 709-729.
- Gittell, J. H. (2006). Relational coordination: Coordinating work through relationships of shared goals, shared knowledge and mutual respect. *Relational Perspectives in Organizational Studies: A Research Companion*, 74-94.
- Hall, D.T. (1976). *Careers in organizations*. Thousand Oaks, CA: Sage.

## **New Technologies, Environmental Uncertainty, and HRM**

---

Regular Session

---

***Dr . Shanggeun Rhee*<sup>1</sup>, *Dr . Silvana Trimi*<sup>2</sup>, *Mr . Rene Kunuria*<sup>1</sup>, *Ms . Tatiana Moreno*<sup>1</sup>**

*1. Kean University , 2. University of Nebraska-Lincoln*

The Insurgency of advanced technologies shakes the business world in two ways. The first is to see it as a positive and productive shaking of business in that new technologies innovate the way to do business and create new jobs that are conducive to innovation. The second notion is that the arrival of emerging technologies is disruptive because it changes the way of doing business and destroys the current existing jobs. Whether it is a positive or negative impact on the business world, one truth is that it increases the environmental uncertainty in business. With the increased uncertainty, employees feel unsafe about their future and seek the way to protect themselves from this unstable situation. This perception of insecurity poses a great threat to their productivity and eventually on overall organizational performance. To stay healthy and productive, organizations need to be proactive in tackling this steaming issue before it gets too late. This study aims to see what actions organizations can take to alleviate the insecure perception of the future by employees and how they can be implemented. After identifying those actions, we will be testing their impact on the individual and organizational performance by comparing firms taking proactive approaches to them with the firms dormant in doing so.

# Want to outperform the competition in domestic and global markets? Focus on effectively managing workforce diversity.

---

Regular Session

---

***Dr . Inessa Korovyakovskaya*** <sup>1</sup>

1. Savannah State University, College of Business Administration, 3219 College St., Savannah, GA 31410. Tel.: (912) 358-3420.

E-mail: korovi@savannahstate.edu.

*Diversity of the workforce in the United States represents the population diversity and continues to grow each year. The total global workforce is projected to be comprised of millennials for 75% by 2025 while millennials represent amore diverse cohort than preceding generations, with 44.2 percent coming from a minority race or an ethnic group(U.S. Census Bureau, 2015). Companies of all sizes in the United States spend billions of dollars annually on diversity training programs to capitalize on the benefits and mitigate the challenges of the diverse workforce with the goal of competing effectively in both domestic and global markets.*

*This study views workplace diversity through the lens of several established theoretical frameworks on the linkages between diversity and organizational performance outcomes. The present study contributes to the extant research on workplace diversity through the development of a new conceptual model that examines the complexities of the relationships between workplace diversity and organizational performance as mediated by diversity management programs and moderated by multi-level organizational variables. Research findings on team and organizational diversity of the past decades report mixed results while most empirical studies on diversity have not explored the complexity of the phenomena. There is a tremendous “potential value of adopting a multidimensional, multilevel approach in future theoretical” and empirical studies (Jackson and Joshi, 2004, p. 698).*

*Benefits and challenges of the workplace diversity are expected to continue to impact organizational performance, therefore it is essential that companies focus on development and implementation of their own best practices in diversity management. It is recommended for companies and diversity managers to use trainings and procedures from the lists of best practices offered by government and professional organizations such as the Equal Employment Opportunity Commission (EEOC) and the Society of Human Resource Management (SHRM) to effectively use available resources and achieve desired results at reasonable costs.*

**Management, Strategy,  
Organizational Behavior,  
Organizational Theory,  
and Human Resource  
Management - Papers**

## **CHILDCARE BENEFITS AS GLOBAL EMPLOYEE RECRUITING AND RETENTION TOOLS**

Courtney N. Strole, Lumpkin College of Business & Technology, Eastern Illinois University,  
600 Lincoln Avenue, Charleston, IL 61920, 217-581-7712, cnstrole@eiu.edu

Marko Grünhagen, Lumpkin College of Business & Technology, Eastern Illinois University,  
600 Lincoln Avenue, Charleston, IL 61920, 217-581-6906, mgrunhagen@eiu.edu

### **ABSTRACT**

Globally, it has become increasingly common for employers, both public and private, to offer benefits packages to their full-time employees. Some of the more common types of employer-provided benefits include health insurance, dental, life insurance, and retirement plans. The variety and range of benefits provided can boost an employee's loyalty to a company and reduce absenteeism, in turn reducing turnover and boosting employee morale, product/service quality, overall productivity, and ultimately firm performance [1][2][3]. Offering employee benefits may also serve as a recruiting tool to attract new employees vis-à-vis competing employers with lesser benefits [4][5].

A relatively new, and not yet ubiquitous, employee benefit entails employers' provision of childcare options [6]. Companies offer such benefits in a variety of ways, ranging from flexible work hours, to paid time off, to tax credits, vouchers for off-site childcare facilities, and on-site day care [7][8][9]. Offering such benefits may allow employees to have a worry-free workday, save money, receive guaranteed childcare, and being able to see the child throughout the workday [10][11].

This research paper contrasts differences in childcare in the five largest global economies (US, China, Japan, Germany, UK) through case studies for each country. In the process, cultural idiosyncracies, such as the value of family as well as the value put on work-life balance in each culture [12][13], will be highlighted to provide rationales for the varying childcare benefits offered.

The findings of this research paper will be important for organizations' decision makers in their efforts to create meaningful benefit structures to attract and retain the best employees, male or female, while considering both costs and benefits of varying approaches. Further, public policy experts may find exemplars and guidance through the contrasting perspectives offered from other parts of the world. Finally, researchers may find a starting point for a fruitful new agenda in the HR Management realm.

## REFERENCES

- [1] Kocakulah, M., Kelly, A., Mitchell, K., Ruggieri, M. (2009), “Absenteeism Problems and Costs: Causes, Effects and Cures” in *International Business & Economics Research Journal*, Volume 8, Number 5.
- [2] Marovich, Miki (2019), “The Negative Impacts of High Turnover Rate”, <https://smallbusiness.chron.com/negative-impacts-high-turnover-rate-20269.html>
- [3] Scorza, John (2011), “Benefits Can Boost Employee Loyalty”, [https://www.shrm.org/resourcesandtools/hr-topics/benefits/pages/benefits\\_loyalty.aspx](https://www.shrm.org/resourcesandtools/hr-topics/benefits/pages/benefits_loyalty.aspx)
- [4] Clarke, Kenneth F. (2001), “What Businesses Are Doing to Attract and Retain Employees – Becoming an Employer of Choice,” *Employee Benefits Journal*, 26(1), 21-24.
- [5] Herrbach, Olivier and Karim Mignonac (2004), “How Organizational Image Affects Employee Attitudes,” *Human Resource Management Journal*, 14(4), 76-88.
- [6] Pena, Samantha (2017), “Offering Child Care Benefits to Employees”, <https://www.wework.com/creator/how-to-guides/employee-child-care-benefits/>
- [7] Cromarty, Hannah (2018), “Childcare Vouchers and Tax-Free Childcare – Frequently Asked Questions” in *House of Commons Library Briefing Paper*, 1-31.
- [8] Baughman, Reagan, Daniela DiNardi and Douglas Holtz-Eakin (2003), “Productivity and Wage Effects of “Family-Friendly” Fringe Benefits,” *International Journal of Manpower*, 24(3), 247-259.
- [9] Scandura, Terry A. and Melanie J. Lankau (1997), “Relationship of Gender, Family Responsibility and Flexible Work Hours to Organizational Commitment and Job Satisfaction,” *Journal of Organizational Behavior*, 18, 377-391.
- [10] Shuiyu, Jing (2017), “Childcare at work offers business benefits: Report”, [http://www.chinadaily.com.cn/business/2017-09/27/content\\_32556920.htm](http://www.chinadaily.com.cn/business/2017-09/27/content_32556920.htm)
- [11] Taurasi, Liz (2015), “Employee Benefits That Help Working Parents with the Cost of Care,” <http://workplace.care.com/7-employee-benefits-that-help-working-parents-with-the-cost-of-care>
- [12] Ikezoe, Hirokuni (2012), “Work-Life Balance in Japan: Outline of Policies, Legal Systems, and Actual Situations” in *Japan Institute for Labor Policy and Training*, 108-124.
- [13] Lewis, Jane, Trudie Knijn, Claude Martin and Ilona Ostner (2008), “Patterns of Development in Work/Family Reconciliation Policies for Parents in France, Germany, the Netherlands, and the UK in the 2000s,” *International Studies in Gender, State and Society*, 15(3), 261-286.

Diversity training: Is it a goal-oriented action or just a business?

Companies are spending multi-million dollars a year on diversity training. The budget set for diversity training enforcement, in addition to the professionals hired to provide consultation and handle diversity related issues are increasing year after year.

Many studies confirm that organizations with diverse workforce have better overall performance and results compared to less diverse ones.

But the main challenge is that there are a lot of doubts regarding the application and fostering of diversity within the organizations that invest a lot on the diversity training. The course of actions taken and applied toward diversity within the organizations does not seem to be different compared to the actions taken a decade ago.

Although technology shaped and enhanced the quality and methodology of providing diversity training to cope with the continuous changing needs in the businesses world, still the results are almost negligible. The proportion of people of color in management positions at major US companies is still below 20 % and it gets worse in the C-level managerial positions.

With the proven path to success of diversity and all the efforts put forth by companies, why doesn't that lead to any fruitful success? Are companies using diversity training as a tool to defend or brand for their organization without having any intentions or goals to enforce diversity? Are organizations willing to follow the recommendations by academia about the training methods that are proven to be more effective in increasing diversity? Are current governmental regulations working properly to improve diversity in private sectors?

This study aims to seek an answer for these fundamental questions by looking at many areas of diversity and provide practical solutions.

## New Technologies, Environmental Uncertainty, and HRM

The Insurgency of advanced technologies shakes the business world in two ways. The first is to see it as a positive and productive shaking of business in that new technologies innovate the way to do business and create new jobs that are conducive to innovation. The second notion is that the arrival of emerging technologies is disruptive because it changes the way of doing business and destroys the current existing jobs. Whether it is a positive or negative impact on the business world, one truth is that it increases the environmental uncertainty in business. With the increased uncertainty, employees feel unsafe about their future and seek the way to protect themselves from this unstable situation. This perception of insecurity poses a great threat to their productivity and eventually on overall organizational performance. To stay healthy and productive, organizations need to be proactive in tackling this steaming issue before it gets too late. This study aims to see what actions organizations can take to alleviate the insecure perception of the future by employees and how they can be implemented. After identifying those actions, we will be testing their impact on the individual and organizational performance by comparing firms taking proactive approaches to them with the firms dormant in doing so.



**Marketing, Consumer  
Behavior, International  
Business - Abstracts**

# Job Expectations of Chinese Professionals: A Critical Analysis and Extension of Previous Research

---

Regular Session

---

*Dr . Tope Adeyemi-Bello <sup>1</sup>, Dr . Cody Logan Chullen <sup>1</sup>, Mr . Xiao-Yu Xi <sup>2</sup>*

*1. East Carolina University , 2. China Pharmaceutical University*

There are numerous studies that have focused on the importance of work to different cultures. The values that different societies accrue to work has also been the focus of additional research. In the current study, we examined the values ascribed to work by Chinese professionals. Our results indicate that there is a statistically significant difference in how professionals and students view work. Perhaps more importantly, we found that there are no gender differences amongst professionals with regard to values placed on various aspects of their jobs.

---

## SCM in crisis time: the role of deindividuation

---

Regular Session

---

***Dr . Rafael Teixeira***<sup>1</sup>, ***Dr . Vinicius Nardi***<sup>2</sup>, ***Dr . Andrea Guazzini***<sup>3</sup>, ***Dr . Diego Pinto***<sup>4</sup>, ***Dr . Wagner J. Ladeira***<sup>5</sup>

1. College of Charleston , 2. Faculdade da Serra Gaúcha , 3. Università Degli Studi di Firenze , 4. Universidade Nova de Lisboa ,  
5. Universidade do Vale do Rio dos Sinos

Every year, extraordinary events, such as hurricanes, flooding, tsunamis, generate fear and uncertainty in peoples' lives and overreaction in the market. In this context, people purchase more products than needed to stock up and prevent problems due to shortage of products. To some extent, this behavior is stimulated by social driven herd behaviors, especially when people are deindividuated. The deindividuation theory (Festinger, Pepitone, & Newcomb, 1952; Postmes & Spears, 1998; Zimbardo, 1969) suggests that the individual submerges to the collective and becomes part of it - factors that cause the decrease of self-evaluation and self-decision. Deindividuation makes individual more susceptible to social influence (Lea, Spears, & de Groot, 2001; Postmes, Spears, Sakhel, & de Groot, 2001) which leads him to adopt social heuristics to determine his behavior. recent studies have shown the natural increase in consumption due to impending disasters. In addition to the obvious preservation instinct, this behavior is related to emotion-focused coping strategies used by individuals when they perceive a lack of control. Additionally, individuals in this case increase their negative emotions such as fear, sadness, anger or anxiety. In this sense, natural disaster alerts are phenomena that recurrently expose the individual to their inability to manage and maintain control over situations (Rodin, 1986; Shapiro, Astin, Shapion, Soucar & Santerre, 2010). As compensation, the individual seeks consumption, especially for utilitarian products. With sequential experimental studies, the present project evaluates the role of deindividuation on the adoption of social heuristics in the risk situation and discuss the consequence of this psychological condition on the crisis supply chain management. Results show that deindividuation increases consumer behavior intention to buy and that risk perception mediates this relationship. This means that, in face of catastrophic events, such as hurricanes, flooding, and tsunamis, people tend to buy more products than normal because of the social heuristics and influence, increasing their risk perception and leading to a shortage of products. To manage this problem and reduce the shortage of products in these extreme conditions, strategies to deindividualize should be adopted.

# Trend, Issues, and Challenges of V-Marketing for Small Businesses in China —An Empirical Study

---

Regular Session

---

*Dr . Jiaqin Yang <sup>1</sup>, Prof . Qiong Song <sup>2</sup>*

*1. Georgia College & State University , 2. Lanzhou University of Arts and Science, China*

Internet has become one of the primary marketing tools for businesses. Meanwhile, with the rapid development of smart mobile devices, mobile marketing is playing an increasing role in business marketing. In this paper, a new definition of V-marketing is proposed, and empirically investigated through a survey research project focused on its application by small businesses in China. V-marketing is about the marketing practices via mobile devices through social media applications, such as Twitter, Facebook, Weibo and Wechat etc. Specifically, this research is an attempt to investigate the current status and trend of V-marketing for small businesses in China.

# USING SOCIAL LEGITIMACY THEORY TO UNDERSTAND THE LIKELY IMPACT OF DIGITAL DIRECT MARKETING ON WEB SALES

---

Regular Session

---

***Dr . Richard Heiens*** <sup>1</sup>, ***Dr . Ravi Narayanaswamy*** <sup>2</sup>

*1. University of South Carolina Beaufort , 2. University of South Carolina Aiken*

*The present manuscript examines digital direct marketing and the most common e-commerce digital sales channels. These digital sales channels include direct website visits, display ads, email, organic search, paid search, referrals, and social media. The theoretical mechanism that serves as the basis for the manuscript is social legitimacy theory. Specifically, the focus is on developing propositions regarding the likely effects of each digital sales channel on both perceived social legitimacy and potential Web sales performance. Although all digital sales channels may generate sales, it is proposed that display ads and paid search may negatively affect perceived social legitimacy.*

# USING THE ARTIFICIAL NEURAL NETWORK FOR PREDICTING PERCEIVED RISK IN FINANCIAL SERVICES

---

Regular Session

---

*Dr . Komlan Gbongli <sup>1</sup>, Mr . Anthony Adu Amponsah <sup>1</sup>*

*1. University of Miskolc*

This study intends to offer an integrated Structural Equation Modeling (SEM) - Artificial Neural Network (ANN) technique for evaluating the perceived risk factors affecting mobile money adoption services in the context of Togolese financial services. This research proposes determinants such as privacy risk, time risk, security risk, and perceived cost. The data collected from both mobile money users and potential users were analyzed using SEM, and ANN approaches.

This study extends previous research in several directions. The results of SEM showed that privacy risk perceived, security risk perceived, and cost perceived exercised significant effect on the aggregate perception of risk for mobile money acceptance and usage. The SEM results were taken as inputs for the ANN approach. The results of ANN emphasized that perceived privacy risk is the most critical determinant for mobile money adoption amongst the respondents.

The primary outcomes of this study revealed that the application of a two-step SEM-ANN approach offers two significant advantages: First, it allows additional verification of the results derived from the SEM analysis. Second, this approach enables apprehending not only linear but also complex nonlinear relationships between antecedents and dependent constructs, particularly measuring of the relative influence of each predictor.

The ANN-based SEM technique could be superior to traditional SEM techniques due to its ability to measure non-linear relations by using different activation functions and layers of hidden nodes. The outcome of the integrated approach is projected to guide the decision and policy-makers for easy evaluation of the various type of risk affecting consumers for choosing mobile money services.

**Marketing, Consumer  
Behavior, International  
Business - Papers**

## **JOB EXPECTATIONS OF CHINESE PROFESSIONALS: A CRITICAL ANALYSIS AND EXTENSION OF PREVIOUS RESEARCH**

Tope Adeyemi-Bello, Department of Management, College of Business, East Carolina University, Greenville, NC 27858, 252-328-4856, [bellot@ecu.edu](mailto:bellot@ecu.edu)

Cody Chullen, Department of Management, College of Business, East Carolina University, Greenville, NC 27858, 252-737-4608, [chullenc@ecu.edu](mailto:chullenc@ecu.edu)

Xiao-Yu Xi, School of International Pharmaceutical Business, Jingguanwen Building, 639 Longmian Road, Jiangning District, China Pharmaceutical University, Nanjing, Jiangsu Province, China, 86-13-852-29-7573, [cpuxixiaoyu@163.com](mailto:cpuxixiaoyu@163.com)

### **ABSTRACT**

There are numerous studies that have focused on the importance of work to different cultures. The values that different societies accrue to work has also been the focus of additional research. In the current study, we examined the values ascribed to work by Chinese professionals. Our results indicate that there is a statistically significant difference in how professionals and students view work. Perhaps more importantly, we found that there are no gender differences amongst professionals with regard to values placed on various aspects of their jobs.

### **INTRODUCTION**

There are indications that after reaching its peak in 2014, the Chinese labor pool is shrinking. According to Han [15], the labor force reached a maximum of about 794 million people in 2014 but has since decreased to about 776 million for 2018. This researcher also noted that the decrease is not only in numerical terms but as a percentage of the share of the Chinese population that is participating in the labor market. There are indications (because of the previous one-child policy) that there are fewer younger people entering the labor force. Therefore, it is important that employing organizations in China ascertain that future and current employees' expectations about their jobs match the reality that they experience.

Work is an important part of human existence [14]. Over the past fifty years, a number of researchers have focused on what current and future employees can expect from their work environment. Herzberg et al. [16] two-factor theory provided the foundational basis for research focused on job expectations. Perhaps, the seminal piece in this area of research inquiry was undertaken by Manhardt in 1972 in developing an instrument that can be used to measure differences in work values research. This scale was developed by Manhardt to provide a less theoretical and more specific method of measuring differences in job orientation. Manhardt [20] found eleven of twenty-five characteristics that distinguished the job expectations of males from those of females in his landmark study. While some studies have provided support for Manhardt's conclusion (e.g., [18]), others have not (e.g., [5]).

Abu-saad and Isralowitz, [1] using a sample of undergraduate students in Israel, found there was no consistent pattern regarding differences among gender pertaining to work values. Females scored higher on extrinsic work values four out of six times. In their study, they found a total of



nine gender differences as opposed to eleven in Manhardt's study [20] and the 18 in Beutell and Brenner's [4] study. No major differences were reported for the common male/intrinsic values among men and women. Six differences were reported according to the female/intrinsic work-based values. There were no significant differences between male and female single/unmarried students while married students had only three of twenty-five significant differences. The three-item difference support the notion that married men may be more dedicated to their careers than married women. Overall, the results of the study agree with Manhardt's conclusion that differences between genders disappear when both genders value their careers the same. For example, careers in medicine typically show the least amount of differences regarding work value characteristics.

Traditionally, it is believed that men bring rationality and aggressiveness to the workplace and that females bring what are more likely to be considered non-managerial characteristics like passivity and nurturing demeanor [17]. In Sagan et al.'s [25] study, no major differences were observed between Polish men and women regarding intrinsic job factors, however, there were nationality differences in comparison to their Russian counterparts. Therefore, while Polish respondents valued 'intrinsic job factors' the Russian respondents preferred extrinsic factors.

Robinson and Beutell [23] in their research study noted that Chinese men and women reported comparable levels of social impact in the retail sector but because of the patriarchal nature of the society, the male salespeople saw themselves as 'inferior'. Previous research on Chinese students by Tomkiewicz et al. [27] found no major differences between men and women regarding intrinsic and extrinsic variables. The weakness of the study was perhaps the small sample size. Nevertheless, the authors concluded that women showed a greater variation for flexible work environment and embrace more of 'a life outside of work'.

In the current study, there are three research questions of interest: (1) What level of importance do Chinese professionals attribute to various aspects of their work environment (i.e., job expectations?, (2) Does the importance assigned to various aspects of the work environment (i.e., job expectations) differ between male and female Chinese professionals?, and (3) Given on-going societal and economic changes in China, how do the job expectations for Chinese working professionals compare with those of Chinese college students?

## **METHOD**

### **Procedure**

The primary source of data for this study was collected through opinion survey. Participants were guaranteed that their responses would be kept strictly confidential and that under no circumstances would anyone be able to individually identify them in any way. Prior to administering the survey, participants were informed of the upcoming study (noting that its purpose was to better understand Chinese professionals' job-related attitudes to help improve the quality of their future work life), were encouraged to participate, and were assured that the data would go directly to the authors and that no one would have access to individual responses. One week later, surveys were distributed in person to participants. These surveys were then filled out anonymously and coded for data entry.

Participants for this study were comprised of 365 Chinese working professionals (100 male, 265 female). Overall, participants were on average, 34.90 years of age, were predominantly married (74.5%), and reported working an average of 46.77 hours per week.

## Measures

### Job Expectations Questionnaire

Job expectations were measured using Manhardt's [20] twenty-five item scale. Participants were asked to indicate how important on a 5-point Likert scale (5=Very Important to 1=Very Unimportant) it was to them to have a job which, for examples: "encourages continued development of knowledge and skills...", "provides the opportunity to earn a high income...", "provides a feeling of accomplishment...", and/or "provides advancement to high administrative responsibility..." Since questions regarding attitudes and opinions may be more abstract and certain concepts may not be relevant throughout the world, this study followed a regimented process of forward-translation and back-translation. First, the questionnaire was translated from English to Chinese (i.e. Mandarin) by one of the co-authors of this study (who is bilingual). To validate the translation, assistance was solicited from another bilingual Chinese professor from a regional university in the United States to translate the survey back into English. This allowed for identification of questionnaire items that may have posed difficulties for this study's Chinese sample. The Chinese professor in the U.S. was then asked to make any modifications that were necessary on those potentially problematic questions identified through the back-translation, given the English language-based original. Subsequently, a bilingual Chinese professor in the UK was asked to translate the revised questionnaire in Chinese back into English. After this iteration, researchers were satisfied with the correspondence between the English and Chinese-based versions of the questionnaire. This measure demonstrated satisfactory reliability overall ( $\alpha=.95$ ), as well as for male ( $\alpha=.96$ ) and female ( $\alpha=.94$ ) participants independently.

### Analytical Approach

This study examined and tested its data in a manner consistent with previous research in the job expectations literature [20] [2] [3] [7] [13] [25] [26] [27] [28]. First, as noted above, respondents were asked to rate Manhardt's [25] 25 job characteristics using a 5-point Likert scale (5=Very Important to 1=Very Unimportant). Mean scores for responses on each of the job characteristics were calculated separately for men and women. In order to answer, "How important do Chinese working professionals rate various aspects of their work environment (i.e. job expectations)?" the mean scores for each of the 25 job characteristics were rank ordered for males and females separately. For example, the job characteristic that received the highest mean score for males was ranked #1 (the most important). Similarly, the job characteristic that received the lowest mean score for males was #25 (the least important). This process was repeated for female respondents. A Spearman rank correlation was then performed to determine whether males and females assigned a similar rank order of importance to these job characteristics (i.e. Was the job characteristic ranked #1 for males also ranked #1 for females?). Higher scores indicate greater similarity. Additionally, paired t-tests were performed on the standard deviations for each job characteristic for males and females separately to determine which group was more homogeneous.

In order to answer “Does the importance assigned to various aspects of the work environment (i.e. job expectations) differ between male and female Chinese working professionals?” an analysis of variance (ANOVA) was performed, comparing the mean scores between males and females on each of the 25 job characteristics individually. This step addresses whether a statistically significant difference exists between males and females on the importance of, for example, “having a job that requires originality.”

Lastly, to answer “Given ongoing societal and economic changes, how do job expectations for Chinese working professionals compare with those of Chinese college students?” Spearman rank correlations and paired t-tests were performed on the current study’s findings on Chinese working professionals and the findings on Chinese college students reported in Chullen et al. [10].

## RESULTS

### Main Findings

Table 1 illustrates the ranks, means, and standard deviations for Chinese male and female working professionals across all twenty-five job expectation questionnaire items.

-----  
Insert Table 1 about here  
-----

Mean scores were calculated for each of the 25 questionnaire items and rank ordered separately for male and female students. The Spearman rank correlation coefficient between the rank orders of male and female respondents was .95 ( $p < .001$ ), indicating that the order of importance which male and female respondents placed on job characteristics was very similar. Significant differences between male and female respondents on the job expectations questionnaire were tested using ANOVA. Significant differences ( $p < .05$  or better) were found on 10 of the 25 items. Females reported higher average scores on all 10 of these items. Mean male standard deviations were .75 and mean female standard deviations were .66, indicating that females were more homogenous than males with respect to job expectations. A paired t-test ( $p < .001$ ) for these standard deviations confirmed females as a group are more homogeneous than are the males.

Both male (mean = 4.19) and female (mean = 4.38) Chinese working professionals indicated that having a job which “encourages continued development of knowledge and skills” was of the highest importance to them (i.e. ranked #1/25). On the other hand, both male (mean = 3.47) and female (mean = 3.57) Chinese working professionals indicated that having a job which “requires supervising others” was of the lowest importance to them (i.e. ranked #25/25).

### Intrinsic and extrinsic perspective of the survey items

To date, an array of research has shown that differences in job expectations, be they intrinsic or extrinsic, are important in informing organizational initiatives for employee attraction, selection, and retention [5] [9] [11] [12] [16] [18] [19] [21]. Manhardt’s [20] 25-item survey instrument can be dichotomized into intrinsic and extrinsic factors based on the locus of incentive from the respondent’s perspective. Intrinsic motivation occurs when an individual derives an internal

pleasure or enjoyment from engaging in a task and where no obvious external incentives are present (e.g. sense of accomplishment). In contrast, extrinsic motivation occurs when an individual engages in behaviors for express external rewards, whether they be tangible (e.g. pay) or intangible (e.g. praise). 13 items (#1, 2, 3, 4, 7, 8, 9, 15, 16, 18, 21, 24, and 25) comprise the intrinsic factor, whereas 12 items (#5, 6, 10, 11, 12, 13, 14, 17, 19, 20, 22, 23) comprise the extrinsic factor. Mean scores for the 13 intrinsic and 12 extrinsic job characteristics were calculated and compared between male and female subjects using ANOVA. Significant differences between male and female participants were found for the intrinsic factor (mean = 3.93 males vs. mean = 4.07 females,  $p < .001$ ) but not for the extrinsic factor (mean = 3.87 males vs. mean = 3.96 females,  $p = n.s.$ ).

### Comparison to Chullen et al. (2015)

Table 2 illustrates the ranks and means for Chinese male and female working professionals across all twenty-five job expectation questionnaire items as reported in the current study and for Chinese male and female students as reported in Chullen et al.'s [10] study.

-----  
 Insert Table 2 about here  
 -----

In 2015, Chullen et al. performed only the second known (and still the most recent) study of gender differences in job expectations of Chinese college students. Drawing on a sample of 430 college students, they found significant differences on twenty-three of twenty-five job expectation questionnaire items. Their results showed that females had statistically significant higher scores on all but two items (i.e. item 2 - "makes use of your specific educational background" and item 17 - "requires supervising others") than their male counterparts. Based on an analysis of standard deviations, females were found to be more homogenous than males with respect to job expectations. An analysis of gender differences in job expectations found statistically significant results for both intrinsic and extrinsic factors.

The current study and its findings vary meaningfully from Chullen et al. [10]. Interestingly, while Chullen et al. [10] found significant differences ( $p < .05$  or better) on 23 of the 25 items between male and female college students, the current study only found significant differences on 10 of the 25 items between male and female working professionals. Also, while Chullen et al. [10] found statistically significant differences on both the intrinsic and extrinsic factors for male and female college students, the current study only found significant differences for the intrinsic factor for male and female working professionals.

In Chullen et al. [10], both male and female college students indicated that having a job which "provides a feeling of accomplishment" was of the highest importance to them (i.e. ranked #1/25). However, in the present study, this item was ranked #5/25 by male working professionals and #4/25 by female working professionals, respectively. In their study, while "encourages continued development of knowledge and skills" was rated as the second most important for both male and female college students, it rose to #1/25 for both male and female working professionals in the current study. The item "requires supervising others" was rated to be of the lowest importance (i.e. #25/25) for female college students (but not male college

students) in Chullen et al.'s [10] study and was evaluated to be of the lowest importance for both male and female working professionals in the current study.

Having a job which "gives you the responsibility for taking risks..." (item 8) showed the largest increase in importance of ranking between male college students in Chullen et al. [10] and male working professionals in the current study, moving from #23 to #10. Interestingly, this same item also showed the largest increase in importance of ranking between female college students in Chullen et al. [10] and female working professionals in the current study, moving from #18 to #11. In contrast, having a job which "provides change and variety in duties and activities..." (item 12, moving from #11 to #21) and which "permits advancement to high administrative responsibility..." (item 14, moving from #10 to #20) tied for the largest decrease in importance of ranking between male college students in Chullen et al. [10] and male working professionals in the current study. Interestingly, item 14 "permits advancement to high administrative responsibility..." also showed the largest decrease in importance of ranking between female college students in Chullen et al. [10] and female working professionals in the current study, moving from #14 to #20.

Table 3 illustrates Spearman rank correlation coefficients for the rank orders and paired t-tests for the mean scores, of Chinese male and female working professionals on the job expectations questionnaire for both the current study and for Chullen et al.'s [10] study.

-----  
 Insert Table 3 about here  
 -----

As noted earlier, the Spearman rank correlation coefficient between the rank orders of male and female Chinese working professionals in the current study was .95 ( $p < .001$ ). In contrast, Chullen et al. [10] reported a Spearman rank correlation of .68 ( $p < .01$ ) for Chinese male and female students. These results suggest that the order of importance that male and female Chinese working professionals place on job characteristics is more homogenous than those of male and female Chinese college students. Additionally, the Spearman rank correlation coefficient was .67 ( $p < .001$ ) between male working professionals in the current study and male college students in Chullen et al.'s [10] study, .91 ( $p < .001$ ) between female working professionals in the current study and female college students in Chullen et al.'s [10] study, .83 ( $p < .001$ ) between male working professionals in the current study and female college students in Chullen et al.'s [10] study, and .71 ( $p < .001$ ) between female working professionals in the current study and male college students in Chullen et al.'s [10] study. These results suggest that the order of importance male college students place on job characteristics from Chullen et al.'s [10] study are similar to those of male working professionals reported here. Likewise, the order of importance female college students place on job characteristics from Chullen et al.'s [10] study are similar to those of female working professionals reported here. Lastly, a comparison of the order of importance between male college students from Chullen et al.'s [10] study and female working professionals from the current study as well as between female college students from Chullen et al.'s [10] study and male working professionals from the current study are also similar.

Additionally, paired t-tests were performed on the mean scores of each of the 25 items comparing the mean scores reported by Chullen et al. [10] with the present sample. These results show that significant differences exist ( $t = 24.40^{***}$ ) between the mean scores of male working

professionals from the current study and male college students from Chullen et al. [10], between the mean scores of female working professionals from the current study and female college students ( $t = 5.80^{***}$ ) from Chullen et al. [10], and between female working professionals from the current study and male college students ( $t = 24.57^{***}$ ) from Chullen et al. [10]. Interestingly, male working professionals in the current study reported significantly higher mean importance scores (3.90) across all twenty-five job expectation questionnaire items as compared to male college students (3.21) in Chullen et al. [10]. However, while female working professionals in the current study reported higher mean importance scores (4.02) on twenty-three of the twenty-five job expectation questionnaire items as compared to female college students (3.81) in Chullen et al. [10], the magnitude of these differences were quite small.

### CONCLUSION

Traditionally, females are depicted as less likely to take certain risks or make extreme sacrifices regarding advancement in their careers. Unfortunately, this may be a common but nevertheless outdated belief amongst managerial ranks. The study by Rynes and Rosen [24], for example, found that there are similar beliefs between men and women regarding employment changes, risk acceptance with relocation, and any functional changes. In essence, their findings indicate that females are not risk averse toward their jobs and are as dedicated to their careers as their male counterparts [24]. In fact, there is research support for the position that women value challenge in their jobs and the accompanying role recognition than men [6]. Consistent with the preceding discussion, the results of our study indicate that for Chinese professionals, there is no observable gender differences in the order of importance that male and female professionals attribute to their work environment. If organizations are not progressive in their attitude toward their female employees, they risk losing their talents and contributions as they are more likely to start their own businesses [22].

### REFERENCES

- [1] Abu-saad, I. & Isralowitz, R. E. Gender as a determinant of work values among university students in Israel. *The Journal of Social Psychology*, 1997, 137(6), 749-763.
- [2] Bartol, K.M. Relationship of sex and professional training area to job orientation. *Journal of Applied Psychology*, 1976, 61(3), 368-370.
- [3] Bartol, K.M. & Manhardt, P.J. Sex differences in job outcome preferences: trends among newly hired college graduates. *Journal of Applied Psychology*, 1979, 64(5), 477-482.
- [4] Beutell, N., & Brenner, O. C. Sex Differences in Work Values, *Journal of Vocational Behavior*, 1986, 26: 29-41.
- [5] Brief, A. P., Rose, G., & Aldag, R. Sex differences in preferences for job attributes revisited. *Journal of Applied Psychology*, 1977, 62(5), 645-646.
- [6] Brenner, O. C., Blazini, A. P., & Greenhaus, J. H. An examination of race and sex differences in managerial work values. *Journal of Vocational Behavior*, 1988, 32, 336-344.
- [7] Brenner, O.C. & Tomkiewicz, J. Job orientation of males and females: are sex differences declining? *Personnel Psychology*, 1979, 32(4), 741-750.
- [8] Brenner, O. C. & Tomkiewicz, J. Job orientation of black and white college students in business. *Personnel Psychology*, 1982, 35(1), 89-103.

- [9] Centers, R., & Bugental, D. Intrinsic and extrinsic job motivations among different segments of the working population. *Journal of Applied Psychology*, 1966, 50(3), 193-198.
- [10] Chullen, C. L., Adeyemi-Bello, T., & Xi, X. Y. Job expectations of Chinese college students: re-examining gender differences. *Equality, Diversity and Inclusion: An International Journal*, 2015, 34(8), 742-763.
- [11] de Vaus, D. & McAllister, I. Gender and work orientation. *Work and Occupations*, 1991, 18(1), 72-93.
- [12] Elizur, D. Gender and work values: A comparative analysis. *The Journal of Social Psychology*, 1994, 134(2), 201-212.
- [13] Frankel, R., Tomkiewicz, J., Adeyemi-Bello, T., & Sagan, M. (2006). Gender differences in job orientation: the case of Poland. *Cross Cultural Management: An International Journal*, 2006, 13(3), 193-203.
- [14] Hamid, A.A., Pettibone, J.R, Mabrouk O.S., Hetrick, V. L., Schmidt, R., Vander Weele, C. M., Kennedy, R. T., Aragona, B.J., & Berke, J. D. *Nature Neuroscience*, 2016, 19 (1), 117-126
- [15] Han, S (2019). <https://www.statista.com/statistics/282134/china-labor-force/>
- [16] Herzberg, F., Mausner, B., & Snyderman, B. *The motivation to work*. Wiley, NY. 1959
- [17] Hochwarter, W. A., Perrewe, P. L & Dawkins, M. C. Gender differences in perceptions of stress-related variables: Do the people make the place or does the place make the people? *Journal of Managerial Issues*, 1995, 7(1), 62-74.
- [18] Loscocco, K. The instrumentally oriented factory worker: Myth or reality? *Work and Occupations*, 1989, 16(1), 3-25.
- [19] Mi' Ari, M. Work satisfaction and gender. *International Review of Modern Sociology*, 1996, 26(1), 67-79.
- [20] Manhardt, P. J. Job orientation of male and female college graduates in business. *Personnel Psychology*, 1972, 25(2), 361-368.
- [21] Neil, C C, & Snizek, W. E. Work values, job characteristics and gender. *Sociological Perspectives*, 1987, 30(3), 245-265.
- [22] Robinson, S. & Beutell, N. J. A study of job attribute preferences among women with a high desire for self-employment. *Allied Academies International Conference*, 2003a, 7(2), 25-29.
- [23] Robinson, S. & Beutell, N. Work values: an updated look at gender differences. *Allied Academies International Conference*, 2003b, 8(1), 69-73.
- [24] Rynes, S, & Rosen, B. A comparison of male and female reactions to career advancement opportunities. *Journal of Vocational Behavior*, 1983, 22, 105-116.
- [25] Sagan, M., Tomkiewicz, J., Adeyemi-Bello, T., & Frankel, R. Importance of job characteristics among future businesspersons: a comparative study of Russian and Polish students. *International Journal of Management*, 2008, 25(3), 641-644.
- [26] Tomkiewicz, J., Brenner, O.C. & Damanpour, F. Gender differences in job orientation: have they changed? *Journal of Global Business*, 1994, 5, 5-76.
- [27] Tomkiewicz, J., Frankel, R., Sagan, M., & Wang, C. Comparing job expectations of Chinese male and female college students. *Chinese Management Studies*, 2011, 5(1), 111-120.
- [28] Tomkiewicz, J., Johnson, M., & Brenner, O.C. Comparing job orientations of Black and White college graduates in business. *Journal of Social Behavior and Personality*, 1997, 12(3), 699-708.

Table 1

<b>Job Expectations Scale Item</b>		Male ( <i>n</i> = 100)			Female ( <i>n</i> = 265)			Significant difference between means
Please circle either a 1, 2, 3, 4, or 5 concerning importance on a continuum which ranges from very important (=5) on the high end to very unimportant (=1) on the low end.		<i>Rank</i>	<i>Mean</i>	<i>S.D.</i>	<i>Rank</i>	<i>Mean</i>	<i>S.D.</i>	
How important is it to you to have a job which:		<i>Rank</i>	<i>Mean</i>	<i>S.D.</i>	<i>Rank</i>	<i>Mean</i>	<i>S.D.</i>	
1.	requires originality...	6	4.03	.81	5	4.25	.62	**
2.	makes use of your specific educational background...	24	3.64	.90	23	3.64	.76	n.s.
3.	encourages continued development of knowledge and skills...	1	4.19	.72	1	4.38	.56	**
4.	is respected by other people...	2	4.09	.74	2	4.30	.59	**
5.	provides job security...	8	4.01	.67	6	4.22	.60	**
6.	provides the opportunity to earn a high income...	9	4.00	.70	7	4.15	.59	*
7.	makes a social contribution by work you do...	13	3.92	.76	12	4.04	.63	n.s.
8.	gives you the responsibility for taking risks...	10 <sup>^</sup>	3.94	.71	11	4.06	.56	n.s.
9.	requires working on problems of central importance to the organization...	14	3.90	.70	18	3.98	.67	n.s.
10.	involves working with congenial associates...	3 <sup>^</sup>	4.07	.73	8 <sup>^</sup>	4.11	.67	n.s.
11.	provides ample leisure time off the job...	16 <sup>^</sup>	3.86	.73	16	4.00	.71	n.s.
12.	provides change and variety in duties and activities...	21	3.74	.84	22	3.72	.81	n.s.
13.	provides comfortable working conditions...	12	3.93	.70	8 <sup>^</sup>	4.11	.64	*
14.	permits advancement to high administrative responsibility...	20	3.80	.82	20	3.92	.72	n.s.
15.	permits working independently...	19	3.82	.70	13 <sup>^</sup>	4.02	.65	**
16.	rewards good performance with recognition...	3	4.07	.70	3	4.27	.60	**
17.	requires supervising others...	25	3.47	.92	25	3.57	.86	n.s.
18.	is intellectually stimulating...	23	3.66	.83	21	3.80	.76	n.s.
19.	satisfies your cultural and aesthetic interests...	18	3.84	.75	17	3.99	.68	n.s.
20.	has clear cut rules and procedures to follow...	10 <sup>^</sup>	3.94	.69	13 <sup>^</sup>	4.02	.66	n.s.
21.	permits you to work for superiors you admire and respect...	15	3.88	.71	19	3.95	.63	n.s.
22.	permits a regular routine in time and place of work...	7	4.02	.65	8 <sup>^</sup>	4.11	.59	n.s.
23.	requires meeting and speaking with many other people...	22	3.72	.79	24	3.62	.84	n.s.
24.	permits you to develop your own methods of doing work...	16 <sup>^</sup>	3.86	.71	13 <sup>^</sup>	4.02	.61	*
25.	provides a feeling of accomplishment...	5	4.06	.65	4	4.26	.59	**

\*  $p < .05$ , \*\*  $p < .01$ , \*\*\*  $p < .001$ ; <sup>^</sup> indicates tie rankings



**Table 2**  
**Comparison of Chinese Gender Differences on Job Expectations Questionnaire Between Students and Professionals**

Job Characteristic	Gender	Students		Professionals	
		Mean	Rank	Mean	Rank
1. Originality, creativeness	Male	3.41	3	4.03	6
	Female	3.89***	11	4.25**	5
2. Use education	Male	3.14	15	3.64	24
	Female	3.32	24	3.64	23
3. Continued development	Male	3.46	2	4.19	1
	Female	4.31***	2	4.38**	1
4. Respect	Male	3.31	7	4.09	2
	Female	4.21***	4	4.30**	2
5. Security	Male	3.19	13	4.01	8
	Female	4.27***	3	4.22**	6
6. Income	Male	3.33	5	4.00	9
	Female	4.09***	6	4.15*	7
7. Social Contribution	Male	3.16	14	3.92	13
	Female	3.82***	13	4.04	12
8. Risks	Male	3.02	23	3.94	10 <sup>^</sup>
	Female	3.68***	18	4.06	11
9. Important problems	Male	3.05	21	3.90	14
	Female	3.40**	21	3.98	18
10. Congenial associates	Male	3.30	8	4.07	3 <sup>^</sup>
	Female	4.01***	8	4.11	8 <sup>^</sup>
11. Leisure time	Male	3.11	19	3.86	16 <sup>^</sup>
	Female	3.91***	10	4.00	16
12. Variety	Male	3.23	11	3.74	21
	Female	3.56**	20	3.72	22
13. Working conditions	Male	3.13	16	3.93	12
	Female	4.02***	7	4.11*	8 <sup>^</sup>
14. Advancement	Male	3.24	10	3.80	20
	Female	3.81***	14	3.92	20
15. Independence	Male	3.13	17	3.82	19
	Female	3.72***	15	4.02**	13 <sup>^</sup>
16. Recognition	Male	3.41	4	4.07	3
	Female	4.20***	5	4.27**	3
17. Supervising others	Male	3.04	22	3.47	25
	Female	2.96	25	3.57	25
18. Intellectually stimulating	Male	3.13	18	3.66	23
	Female	3.36***	22	3.80	21
19. Cultural and Aesthetic	Male	3.11	20	3.84	18
	Female	3.72**	16	3.99	17
20. Rules	Male	3.32	6	3.94	10 <sup>^</sup>
	Female	3.64*	19	4.02	13 <sup>^</sup>
21. Superiors you admire	Male	3.01	24	3.88	15
	Female	3.71***	17	3.95	19
22. Regular routine	Male	3.20	12	4.02	7
	Female	3.98***	9	4.11	8 <sup>^</sup>
23. Personal contacts	Male	2.98	25	3.72	22

24. Own methods	Female	3.34***	23	3.62	24^
	Male	3.26	9	3.86	16^
25. Accomplishment	Female	3.83***	12	4.02*	13
	Male	3.67	1	4.06	5
	Female	4.43***	1	4.26**	4

\*  $p < .05$ , \*\*  $p < .01$ , \*\*\*  $p < .001$ ; ^ indicates tie rankings

**Table 3**  
**Paired t tests and Spearman Rank Correlations: Current Professionals Study versus 2015 Student Study**

<i>Group</i>	<i>Mean</i>	<i>SD</i>
Current Professional Males (1)	3.90	.16
Current Professional Females (2)	4.02	.22
2015 Student Males (3)	3.21	.16
2015 Student Females (4)	3.81	.36

<i>Group</i>	<i>t values</i>	<i>r<sub>s</sub> values</i>
(1) vs. (3)	t = 24.40***	.67***
(2) vs. (4)	t = 5.80***	.91***
(1) vs. (4)	t = 2.04	.83***
(2) vs. (3)	t = 24.57***	.71***

\*  $p < .05$ , \*\*  $p < .01$ , \*\*\*  $p < .001$

## **TREND, ISSUES, AND CHALLENGES OF V-MARKETING FOR SMALL BUSINESSES IN CHINA: AN EMPIRICAL STUDY**

Qiong Song, Lanzhou University of Arts and Science, Lanzhou, China, Email:

[joanwater@163.com](mailto:joanwater@163.com)

Jiaqin Yang, Georgia College & State University, Milledgeville, Georgia, Email:

[jiaqin.yang@gcsu.edu](mailto:jiaqin.yang@gcsu.edu)

### **ABSTRACT**

Internet has become one of the primary marketing tools for businesses. Meanwhile, with the rapid development of smart mobile devices, mobile marketing is playing an increasing role in business marketing. In this paper, a new definition of V-marketing is proposed, and empirically investigated through a survey research project focused on its application by small businesses in China. V-marketing is about the marketing practices via mobile devices through social media applications, such as Twitter, Facebook, Weibo and Wechat etc. Specifically, this research is an attempt to investigate the current status and trend of V-marketing for small businesses in China.

### **Introduction**

In 1996, IBM's marketing and Internet team created a new term "e-business" (electronic business) [6]. The next year, it became the first company to introduce the concept of "e-business" in Wall Street Journal and launched a campaign to advertise IBM's expertise in this new field [15]. However, IBM decided not to trademark the term "e-business", in order to give other companies an opportunity to use the term and create a brand-new industry. By 2000, it is proved to be so thoughtful to make this decision, because since that time, the term of "e-business" has become a reality of the common commercial activities [13]. E-marketing refers to the application of marketing principles and techniques by using electronic media, especially the Internet. It is the process of marketing a product or services through the Internet [16] These electronic technologies are valuable supplement to traditional marketing regardless of the size and type of the business. E-marketing is also known as Internet-marketing, web-marketing or online marketing.

Compared with traditional marketing, e-marketing has more advantages in many aspects. For example, if used correctly, the benefit and effectiveness of e-marketing could be much greater than that of traditional marketing, because it is easy for updating and adopting with low-cost nature [16]. For all types of businesses, Internet has become an important force among various marketing alternatives. First, the scope and options of e-marketing channels are broader than that of traditional marketing. As an online channel, e-marketing makes it possible for marketers to reach anyone in the world who has an Internet access and enables them to offer their products and services in a wide range. In addition, e-marketing can also make more immediate impact on customers. For instance, an updated on-line advertisement jumping off a smartphone screen can allow the user to visualize a new product/service, experience its functions and even make an order at once just by clicking a few links, which is clearly unimaginable through traditional media. As such, e-marketing has made business like open 24/7. Unlike other traditional marketing methods, Internet allows customers to find out and purchase any product they want at any time, even if the physical store is closed or doesn't exist [16]. Furthermore, e-marketing makes the marketing costs much lower than traditional marketing through use of electronic media. With traditional marketing, such as launching advertisement on magazines, newspapers, billboards, radio and TV, it consumes

a huge amount of financial resources for a better advertising quality with design, printing and even high-grade paper. In comparison, the cost of e-marketing will be much lower, because there are plenty of free platforms available for Internet marketing, such as e-mails, blogs and Facebook, all are low-cost marketing options. These technologies actually open a new entry especially for small businesses to reach potential customers in a wider range with a smaller budget [13].

Today, e-marketing not only refers to marketing on the Internet, but also includes marketing through wireless media or mobile platform, such as smartphone and tablet. This is so-called “mobile marketing”. Currently, “mobile marketing” has been defined as “any marketing activity conducted through a ubiquitous network to which consumers are constantly connected using a personal mobile device” [10]. It has been well-known that people like to spend more time on mobile devices rather than desktop. They expect to acquire more information at their fingertips. Up to 2014, the number of global mobile Internet users has exceeded that of desktop Internet users according to published statistics. Like in America, people spend 2.7 hours per day on average on their mobile devices [26]. Meanwhile, many online social media applications emerged and have become a part of people’s daily life, such as Facebook, Twitter, Instagram, Skype etc., and Twitter is the most popular one among them. Twitter started in 2006 in the United States, and quickly became very popular worldwide. It is a social media platform that enables users to post and read “tweets”, short messages within 140 characters. Twitter can be accessed by users through online website, SMS (short messages) or app on mobile devices [31]. In 2013, it has become one of the ten most popular social media applications, and by the end of 2014, Twitter had more than 284 million active users in the world [1] [32]. The popularity of these social media applications has promoted the rapid development of consumption through mobile Internet [26].

In recent years, the mobile marketing that based on social media applications is not only getting more popular in those advanced countries, but also in some emerging economy nations like India, Brazil, Russia and China. For example, Chinese mobile Internet users had reached over 400 million by 2013, among which the number of active smartphone usage was 330 million, moreover, the range of Chinese smartphone users extends not only to cities but also to rural areas, providing a great potential for marketing [17]. At the same time, a lot of social media applications have been created and are playing important roles in marketing in China. Two of the most widely used applications are Weibo and Wechat. Weibo has the similar functions as Twitter, and is considered as the counterpart of Twitter in China. Wechat was launched in January 2011, it is a mobile communication service app, through which users can send and receive messages in forms of text, images, voices and videos. In addition, it also has features similar to Facebook and Skype, because users can post news or photos and even make video calling through Wechat. It has been adopted by over 300 million users in only 3 years, and has become one of the major channels of mobile marketing for businesses in China [24]. Giving all discussions above, a new definition of V-marketing is used in this research, which refers to the marketing practices on mobile devices (i.e. tablets and smartphones etc.) through social media applications, such as Twitter, Facebook, Weibo and Wechat etc.

A recent report has shown some cogent statistics of how fast V-marketing has developed in China [28]. For instance, it reveals that the marketing budgets on mobile of Chinese companies has reached to 28% of their overall marketing budgets, and mobile searching has taken 39% of the companies’ web traffic, as a result, 27% of their e-sales proceeds is generated from the

transactions on mobile devices. A more important finding is that 72% Chinese enterprises believe that mobile communication will become the primary focus of their marketing strategy in the near future [28]. It has been realized that mobile devices are made especially for small business because of the flexible and low-cost nature. Although there is great disparity between small business and big chain stores when it comes to physical capacity, they share the same-sized marketing chance on mobile devices, and in fact, to some extent, small business has more advantages in mobile marketing. For example, since a small business normally has a smaller customer base compared with a big business, it is easier for it to learn about how its customers respond to its marketing practices. That is, small businesses can make market segmentation and positioning more effectively so as to meet different needs of their customers [11].

According to recent reports, the number of small businesses in China has reached over 40 million, accounting for 99% of all the businesses. They have made a huge contribution of 65% to China's gross domestic product (GDP), 50% to taxation and 75% to urban employment [22]. Especially after the implementation of some new government regulations that simplified the procedures and lowered the access threshold of business entry in March 2014, a boom of small businesses has followed and more than 1.76 million small businesses were registered thereafter [3]. Small businesses are flourishing in China and have become the backbone for alleviating employment pressures and stabilizing the society, and will become the key force of the development of overall productivity. However, compared to large businesses, the limitations in their restricted resources forced small businesses to explore a new marketing approach that is more effective and lower in cost. Mobile Internet precisely provided the perfect tool and much-needed marketing platform for small businesses. In 2011, mobile Internet sprung up in China and has tended to maturity by 2013. The characteristics of mobile Internet enable small businesses to communicate with customers anywhere anytime, and the mobile applications are powerful channels for small businesses to develop new brand, display products and launch marketing campaigns. Taking Wechat as example, it is reported that 67.5% of the businesses that use Wechat as mobile marketing platform are small businesses [29].

Mobile marketing platform like Wechat has become increasingly important for Chinese small businesses and has great potential down the road. In summary, there is quite limited published research works in the current literature on this new marketing channel. As a result, this paper is an attempt to empirically investigate the trend, issues and challenges of V-marketing for small businesses in China.

## LITERATURE REVIEW

Along with the development of e-marketing, there has been a research stream in the current literature addressing various issues of e-marketing and related challenges. Sheth and Sharma [19] show that e-marketing strategies have been developing and changing dramatically, as a result, the future e-market may be much different from what we know today. An online e-marketing course summarizes the advantages of e-marketing over traditional marketing from six aspects: global reach, wider scope, better interactivity, immediate impact, accurate targeting and closed loop marketing. Brodie et al [2] indicate that e-marketing has started to increasingly penetrate into people's daily life at such a speed that companies that have e-marketing in place performed much better than their counterparts, and e-marketing thrived rapidly on the foundation of pre-existing

marketing practices by integrating with other marketing channels. Meanwhile, Gilmore et al [7] investigate the impact of Internet on SMEs (small to medium-sized enterprises) marketing practices, and reveal that although e-marketing strategies have been used by the majority of SMEs for several years, there is still great room for further improvement.

With the advancement of e-marketing and mobile devices, the research on mobile marketing has been growing. At its early stage, the issues mainly focused on mobile marketing acceptance. Facchetti et al [5] indicate that the relationship between mobile marketing and traditional marketing is not as complementary as it should be, thus the mobile marketing should be further defined and explored. Another research reveals the importance of mobile portal to a branded enterprise, and suggests that a branded mobile portal can create an interactive relationship with customers and identify targeted customers by their identity, consuming behavior, social communication style and geographic position [8]. The study on mobile marketing has become broader and much more extensive. Shankar et al [18] publish a research on the increasing importance of mobile marketing in retailing businesses, and show that mobile marketing has generated a great change for retailers from passively waiting for customers coming into retailing stores in the past to now proactively accessing customers anytime and anywhere through mobile devices. Litster [11] encourages small businesses not to be afraid of the costs and complicated technology of mobile marketing, and reveals that mobile devices (e.g. smartphone) and small businesses are a good match for marketing. In recent years, companies all over the world are engaging in the development of mobile marketing. Moth [14] provides a general picture of the current status of mobile marketing in China with more than 20 statistics, and discovers that about 72% Chinese enterprises planning to make mobile a main focus of their marketing strategy in 2015.

One of the major disadvantages of small businesses in today's market is the limited budget in marketing, which often makes the owners of small businesses facing a dilemma of how to allocate their budgets in various marketing channels. An article summarizes several basic suggestions for advertising agencies to get a better understanding of SMEs marketing budgets [30]. It was found that most of SMEs often have no specific budget for their marketing, more than 60% even have no marketing budget at all. Tight budget is a common issue for SMEs, therefore, the stream of literature on this issue in recent years mainly focuses on how to help SMEs to market themselves more successfully at lower costs. Siu & Liu [20] propose that Chinese SMEs should make a precise analysis on their market status and adopt more advantageous marketing strategies if they want to promote themselves in a more effective way. A blog article posts a few marketing proposals for SMEs, and most of them are related to e-marketing and mobile marketing, such as produce videos on website, create public accounts and make full use of social media platforms, launch online contests and use e-mails for marketing, etc. [34]. McNaught [12] has explained in details why SMEs should use mobile marketing. More specifically, the smartphone is used as the example of mobile devices in the article with the following conclusions: smartphone has become a crucial part of people's life and made people be addicted to their own personal screens; the usage of smartphones is still rising at a high speed; the main functions of smartphones are searching, surfing and socializing, thus it provides a possibility for SMEs of being searched out in a minute; if the information of a business can easily be accessed, it is more likely to convert a searcher into a potential customer, so mobile marketing could be considered as the easiest and most effective way for SMEs to market their own brands.

A lot of social media applications have become the best channels of conducting e-marketing, especially for SMEs. Stelzner [21] ranks the most commonly used social media marketing tools in terms of the percentage of usage, the top three are Facebook (92%), Twitter (84%) and LinkedIn (71%). It is proposed by [9] that SMEs should adopt online marketing strategy to access their customers and enhance the transactions and relationship with customers, as such to reduce the burden on their budgets and human resources. It indicates that as one of the biggest social media in the world, Facebook is just such a perfect selection for this purpose. In addition, there are also plenty of research on Twitter's function in e-marketing, as Twitter has become the most popular social media on the Internet, providing great platforms for all enterprises to conduct their own interactive and customer-oriented marketing [25]. Similarly, the counterpart of Twitter in China, Weibo, has also been fully utilized as a new emerging e-marketing platform. The definition of Weibo marketing can be seen on the website with the following statement: using Weibo as a marketing platform and taking each follower as a potential marketing target, the enterprises promote their own brands by updating the contents of official Weibo, and finally achieve the purpose of marketing by communicating with followers about the updated contents, it is called Weibo marketing (baidu.com). Finally, another social media platform, Wechat, possesses the same popularity in marketing in China. In recent years, Wechat marketing even appears to be more popular than Weibo marketing, as shown in [24], in which a detailed online analysis (searchenginejournal.com) claims that Wechat will be a new and powerful e-marketing channel for Chinese enterprises to promote awareness and build customer loyalty in the next decade. It further argues that Wechat is quite different from or even superior to Weibo, because it can provide not only displaying of text and images but also showing of sound and videos for enterprises to market themselves. Furthermore, its location-recognition function enables the marketers to send promotional messages to targeted customer groups according to their specific location.

In this research, the mobile marketing channels, including Facebook, Twitter, Weibo or Wechat as discussed above, would be all defined as V-marketing. The following sections will describe an investigation about the trend, issues and challenges of V-marketing for small businesses in China.

### **RESEARCH METHODOLOGY**

The data of this research are collected from a pre-designed survey questionnaire. The participants of this survey are selected in a Northwestern city of China. In order to investigate the importance, trend and issues of V-marketing for small businesses in China, the questionnaires are distributed to 300 selected participants who are working for or related to small enterprises. 214 questionnaires have been returned, among which 200 are effective.

The questionnaire has been divided into 4 sections with 26 questions in total. Section 1 is for demographic information, including gender, age, education background, position in business, as well as the size, type, history, annual revenue and targeted customer category of business. The first four items, like most other similar surveys, are intended to get a general picture of participants' overall information. Items 5-8 are very important to ensure if the involved business can be defined as a small business by business size, type, history and annual revenue. Item 9 is designed to check the age distribution of targeted customers by the selected small businesses participated in this research, the result of this item may provide an indication about future V-marketing direction.

Section 2 mainly refers to relative information of Internet marketing channels. Item 10 is aimed at checking the personal Internet usage with mobile devices, in order to estimate the penetration

of mobile Internet among the respondents. Items 11 and 12 focus on the marketing channels of the participants' business, helping to judge if the business is Internet-marketing-oriented. Based on the information of Items 11 and 12, the next two questions explicitly ask the Internet-marketing-oriented businesses about the related information of Internet marketing channels, which in turn will provide a measure to show if V-marketing plays an important role comparing to other Internet marketing channels. Item 15 assesses the anticipated increase of V-marketing to overall marketing in the business since the beginning of the application of V-marketing. Item 16 is designed to further examine if V-marketing is a key to the survival of the small enterprises in future E-business market.

Section 3 covers the relative information of V-marketing channels. Items 17 and 18 check the application history and updating frequency of the participants' official Weibo/Wechat, while the following Item 19 investigates the major contents and forms of Weibo/Wechat. These three questions will show a basic pattern of the status of V-marketing in small businesses and the diversity of V-marketing approaches. Item 20 is about the followers' quantity of official Weibo/Wechat of a business, and Item 21 reflects the increase of customer number that attracted by V-marketing platforms since the beginning of the application of V-marketing. Item 22 aims to show how the total revenue of the participated firms has increased after using V-marketing in terms of an estimated percentage range. The next two questions both relate to the cost of V-marketing, through which a positive trend of V-marketing investment might be identified. Items 25 and 26 are supposed to examine the popularity of preference of small business in choosing payment methods. Item 27 asks the respondents about the major challenges in the process of their V-marketing application. At the end of Section 3, Item 28 focuses on assessing if small businesses have confidence in future V-marketing development.

### DATA ANALYSIS AND MANAGERIAL IMPLICATIONS

The data collected from the proposed survey have been summarized in the following tables and figures. The discussion about the potential managerial implications are presented below.

**TABLE 1: DEMOGRAPHIC INFORMATION**

<b>Gender</b>	Male		Female			Total
	29.3%		70.7%			100%
<b>Age</b>	< 25	25-30	31-40	41-50	> 50	Total
	17.5%	38.6%	26.3%	14.1%	3.5%	100%
<b>Education</b>	≤ High School	Junior College	Under-graduate	≥ Graduate	Other	Total
	32.1%	37.5%	28.6%	1.8%	0%	100%
<b>Position</b>	Business Owner	Administrative Staff	Ordinary Staff	Other		Total
	22.2%	35.2%	29.6%	13%		100%



**Table 1** displays the basic demographic information regarding the gender, age, education background and business position of the respondents. For example, about 70% of the survey respondents are female, which clearly indicates that V-marketing has become a new professional field for young professional women in China. It can also be seen that most of the respondents (over 64%) are in the age group of 25 to 40, which can be viewed as an evidence that V-marketing may become a new and better career for young or middle-aged professionals, due to their relative familiarity of Internet and better skills of information technology. In terms of education background, about 2/3 of the respondents have a college or undergraduate education, while another 1/3 have a degree of high school or under. It shows that V-marketing is not a highly technology-oriented profession, compared to other popular I.T. professions. As for position, over half of the respondents are business owners or high-level administrators, which shouldn't be surprised with the fact that owners and administrators in small businesses are more likely to manage or operate V-marketing directly due to the size of their businesses.

**TABLE 2: BUSINESS INFORMATION**

<b>Business Size</b>	≤ 20	21-50	51-100	100-199	≥ 200	Total
	65.4%	12.7%	5.5%	5.5%	10.9%	100%
<b>Business Type</b>	C & E	Retail	Education	Service	Other	Total
	13.8%	41.4%	5.2%	12%	27.6%	100%
<b>Business History</b>	< 1 year	1-3 years	3-5 years	> 5 years	Total	
	15.4%	17.3%	23.1%	44.2%	100%	
<b>Annual Revenue</b>	< 200	200-500	500-1000	1000-5000	> 5000	Total
	36.4%	14.5%	20%	23.6%	5.5%	100%
<b>Targeted Customer</b>	≤ 15	16-18	19-30	31-49	≥ 50	Total
	6.1%	16.6%	33.9%	33%	10.4%	100%

The general business information is summarized in Table 2, including the size, type, history, annual revenue and targeted customer categories of a business. As expected, over 65% respondents come from a business with less than 20 employees, a typical small business that this research attempts to target. The difference in size provides a direct reflection on annual revenue. More than half of the selected businesses generate a revenue of under 500,000 RMB (less than 80,000 USD) per year, of which the majority even have a revenue of less than 200,000 RMB (about 30,000 USD). As regard to business type, 41.4% of the participants work for retailing industry, which is quite normal as most small businesses concentrate into this industry due to its low-entry cost nature. The survey result also shows that the history of majority of selected businesses (over 55%) are under 5 years, which demonstrates that V-marketing can provide a powerful market channel for new businesses. Finally, as shown in this table, the targeted customers of the selected businesses are mainly between the age of 19 to 49, a strong signal that young and middle-aged consumers are major targeted customers of small business, because they are the

customers who have relatively steady income and up-to-date computer skills which make them more acceptable to V-marketing.

**TABLE 3: INTERNET MARKETING INFORMATION**

<b>Personal Data Flow</b>	< 500M		500M - 1G		> 1G		Total
	12.5%		35.7%		51.8%		100%
<b>Marketing Channels</b>	N & M	Radio & TV	Outdoor ads	Internet	SMS	Other	Total
	9.2%	8.2%	17.3%	38.8%	9.2%	17.3%	100%
<b>Internet Marketing Channels</b>	Website	Blog	Weibo	Wechat	E-mail	Other	Total
	15.5%	3.6%	20.9%	40%	9.1%	10.9%	100%
<b>Ratio Increase of V-marketing</b>	< 10%	10%-30%	30%-50%	50%-80%	> 80%	Total	
	24.1%	40.7%	24.1%	11.1%	0%	100%	
<b>V-marketing Importance</b>	Extremely		Very	Important	Not		Total
	3.5%		57.9%	35.1%	3.5%		100%

(Note: 1. Marketing Channels: N – newspaper, M – magazines. 2. Ratio Increase of V-marketing: the current ratio increase of V-marketing to the overall marketing, compared to the beginning of the application of V-marketing. )

Table 3 covers the Internet marketing related information. Item 1 is divided into three categories according to the current status of Chinese mobile operation. It shows that more than half of the respondents have their monthly data flow over 1G besides the use of Wi-Fi. This information may be used as a measure of how frequent the respondents use wireless devices. Regarding to market channel allocation, as predicted in the previous research, it is very normal to get the result that Internet has occupied over 1/3 of marketing channels, far beyond other traditional media like newspaper, magazines, radio, television and outdoor advertisements etc. It confirms that Internet has certainly become the most important channel for marketing. Furthermore, in terms of Internet marketing, Weibo and Wechat take a large proportion of 60.9%, which obviously provides evidence that V-marketing tends to be the dominating part among many Internet marketing tools. Following is about current V-marketing status, about 2/3 of the selected businesses indicated that their V-marketing has increased by 10% to 50%. In addition, 61.4% of the respondents rank V-marketing “Extremely Important” or “Very Important”, and another 35.1% rank it “Important”, that is, 96.5% of all participated businesses have realized the significance of V-marketing to their success. All these results verify that V-marketing has been accepted greatly by small businesses and is growing positively. As such, one can conclude that the importance of V-marketing to small business has been confirmed empirically by the data of this research.

**Table 4: BASIC WEIBO/WECHAT INFORMATION**

<b>Using History</b>	< 1 year	1-3 years			3-5 years		> 5 years	Total	
	32.8%	53.5%			10.3%		3.4%	100%	
<b>Updating Frequency</b>	Improved				Unchanged			Total	
	58.1%				41.9%			100%	
<b>Content Categories</b>	S.P.	A.C.	T & P	P.P.A.	S.A.	I.F.	Other	Total	
	19.5%	22.2%	33.3%	4.6%	4.6%	6.5%	9.3%	100%	
<b>Followers Number</b>	< 200	201-1,000		1,001-4,999		5,000-20,000		> 20,000	Total
	21.1%	46.3%		26.9%		3.8%		1.9%	100%

(Note: 1. Updating Frequency: compared to that of the beginning of its official Weibo/Wechat application. 2. Content Categories: S.P. – Sales Promotion, A.C. – Advertising Campaigns, T & P – Text & Pictures, P.P.A. – Participating in Public-interests Activities, S.A. – Soft-text Advertisement, I.F. – Interaction with Followers. )

A numerical statement of basic Weibo/Wechat information is provided in Table 4. It can be seen from the results that more than 90% of the selected businesses have been using Weibo/Wechat for less than 5 years, in which over half of them have a using history of 1 to 3 years. It may present that Weibo and Wechat are relatively new tools for marketing attributed to the short history of their application in practice. The second item displays that over half of the selected businesses (58.1%) has improved the updating frequency of their official Weibo/Wechat, which reflects that these small businesses may already get benefits from V-marketing and are tending to pay more attention to further explore its potential. As regard to content categories of business official Weibo/Wechat, a proportion of 1/3 is taken by text and pictures, another 1/3 are sales promotion (19.5%) combined with advertising campaigns (22.2%). This provides a clear pattern that businesses are more likely to choose an easy-to-follow and visualized form to promote themselves through Weibo/Wechat. It can be found in the last item that 46.3% of the selected businesses only have 200 to 1,000 Weibo/Wechat followers, another quarter (26.9%) have 1,000 to 5,000 followers. This result exposes that small businesses are now facing a fierce competition in V-marketing and it may be a big challenge for them to enlarge the number of followers and improve the reputation of their businesses.

Table 5 presents primary information of V-marketing performance of small businesses selected in this research. Regard to the current increase of the customer that added by V-marketing since the application of this channel, the result shows that a large proportion of the selected businesses (40%) have a customer increase from 10% to 30%, then following with a better performance (29.1%) from 30% to 50%, and only a small portion of them (7.3%) perform excellently by having a customer increase of 50% -70%. Item 2 refers to the current increase of the revenue that generated by V-marketing and is closely associated with Item1. It shows clearly that the result of revenue increase appears very consistent to the result of customer increase as expected. The result above has undoubtedly confirmed that V-marketing has contributed to the success and development of

selected small businesses. However, there is still room for them to continuously improve their performance. As to average annual cost of V-marketing, the data displays that nearly 80% of selected businesses spend less than 50,000 RMB (8,000 USD) on V-marketing each year, among which a large proportion of them (40.8%) even have an annual V-marketing cost of less than 10,000 RMB (1,600 USD). This may be an obvious reflection of the fact that the low-cost nature is one of the most important advantages of V-marketing. Based on the data of annual V-marketing cost, it is not surprisingly to find in the last item that over half of the selected businesses have increased their investment in V-marketing and almost all of the rest (38.1%) have made their V-marketing investment keep in the same level with last year. It can certainly be viewed as an optimistic signal for future V-marketing development.

**Table 5: V-MARKETING PERFORMANCE INFORMATION**

<b>Ratio Increase of Customers</b>	< 10%	10%-30%	30%-50%	50%-70%	> 70%	Total
	23.6%	40%	29.1%	7.3%	0%	100%
<b>Ratio Increase of Revenue</b>	< 10%	10%-30%	30%-50%	50%-70%	> 70%	Total
	26.6%	46.9%	16.3%	6.1%	4.1%	100%
<b>Average Annual Cost of V-marketing</b>	< 10	10-30	30-50	> 50	Total	
	40.8%	24.5%	14.3%	20.4%	100%	
<b>V-marketing Cost Change</b>	Increase		Decrease		No change	Total
	54.8%		7.1%		38.1%	100%

(Note: 1. Ratio Increase of Customers: the current estimated increase of the customer base (by %) that added by V-marketing channels to the total customer base, compared to the beginning of the application of V-marketing. 2. Ratio Increase of Revenue: the current estimated increase of the revenue (by %) that generated by V-marketing channels to the gross revenue, compared to the beginning of the application of V-marketing. 3. Average Annual cost of V-marketing: in 1,000 RMB. 4. V-marketing Cost Change: compared to last year.)

Finally, the issues and challenges of V-marketing for small businesses are investigated and summarized in Table 6. The result of Item 1 shows that cash is still the most basic payment method for selected businesses, which accounts for 28.9%, then follows credit/debit card (24.2%). In contrast, some online payment methods, and online banking, only take a small percentage of about 15% respectively. Additionally, it is showed in Item 2 that cash is also the best-loved payment method for selected business and accounts for over 1/3 among all payment methods. Like the result of Item 1, the second favorite choice of payment method appears to be credit/debit card (21.7%). A few must-mentioned potential challenges in V-marketing are given in the survey and the participants are asked to make the response, the results are listed in Item 3 of Table 6. It is not surprising to find that more than 1/3 of the selected businesses consider payment security as their potential challenge, which means payment security issue is still the major concern for small businesses in China. It is a clear reflection of the fact that payment fraud issue has not been solved

till recent. When it refers to the future plan of V-marketing, half of the selected businesses are considering about further developing V-marketing, and 29.6% of them even have had specific plan already. This discloses that an overwhelming majority of small businesses participated in this research think highly of V-marketing prospect and regard it as an appropriate marketing channel for the future.

**Table 6: ISSUES & CHALLENGES**

<b>Payment Method</b>	Cash	Credit/Debit Card	Alipay	Wechat	Online Banking	Other	Total	
	28.9%	24.2%	14.8%	14.1%	17.2%	0.8%	100%	
<b>Preferred Payment Method</b>	Cash	Credit/Debit Card	Alipay	Wechat	Online Banking	Other	Total	
	42.2%	21.7%	7.2%	10.8%	16.9%	1.2%	100%	
<b>Potential Challenges</b>	D.S.		P.S.		H.C.N.F.		Other	Total
	22.2%		42.9%		20.6%		14.3%	100%
<b>Future Plan</b>	Already planned.		Under consideration.			No plan.		Total
	29.6%		50%			20.4%		100%

(Note: 1. Potential Challenges: D.S. – Delivery speed, P.S. – Payment security, H.C.N.F. – Handling of customers' negative feedback. 2. Future Plan: if the business plan to further explore V-marketing with increased resources in the future.)

## CONCLUSIONS

This paper presents an empirical study about the trend, issues and challenges of V-marketing for small businesses in China. The results of this research show a strong evidence that V-marketing tends to be the most powerful marketing channel for small businesses in China, and has been accepted greatly by small businesses. Specifically, it is shown that V-marketing has become a new professional field for young professionals and entrepreneurs, and it is more appropriate for the new small businesses which engage in those traditional low entry-cost industries. Moreover, the research confirms that though Weibo and Wechat are relatively new Internet marketing platforms in China, a large amount of small businesses have already get benefits from these new emerging Internet marketing applications and are planning to further explore their potential. In other words, low-cost nature appears to be the most important advantages of V-marketing that makes small businesses prefer this marketing channel. However, it is also revealed that small businesses are now facing a fierce V-marketing competition and there is still great potential for them to continuously improve their performance. In addition, this paper exposes that payment security issue is still considered as the biggest challenge for small businesses in China, which reflects that there is an urgent need in China on solving payment fraud issue. In summary, most of the small businesses in China believe in the great future of V-marketing application and V-marketing will

play increasing important role in the success and development of small businesses in the current Internet era.

This paper is the first stage of an on-going research project. More in-depth follow-up research will be conducted based on the result of this research, such as a comprehensive survey which will include wide range of different industries and different size of businesses, a focused study on the perception about v-marketing from consumers' perspective, and finally, a research on the reaction and response of marketing analysis about the application and potential of V-marketing.

### References

- [1] Boorstin, J. (2014). With 300M users, Instagram is now bigger than Twitter. <http://www.cnbc.com/2014/12/10/>.
- [2] Brodie, R. J., Winklhofer, H., Coviell, N. E., & Johnston, W. J. (2007). Is E-marketing Coming of Age? An Examination of the Penetration of E-marketing and Firm Performance. *Journal of Interactive Marketing*, Volume 21, Issue 1, pp.2–21.
- [3] Butler, S., & Halder, B. (2015). China's Big Boom in Small Companies. <http://www.ozy.com/fast-forward/chinas-big-boom-in-small-companies/39516>.
- [4] Eid, R. & El-Gohary, H. (2013). The Impact of E-marketing Use on Small Business Enterprises' Marketing Success. *The Service Industries Journal*, Volume 33, Issue 1, pp. 31-50.
- [5] Facchetti, A., Rangone, A., Renga, F. M., & Savoldelli, A. (2005). Mobile Marketing: An Analysis of Key Success Factors and the European Value Chain. *International Journal of Management and Decision Making*, Volume 6, Issue 1.
- [6] Gerstner, L. (2002). Who says Elephants Can't Dance? Inside IBM's Historic Turnaround. ISBN 0-06-052379-4, pp. 172.
- [7] Gilmore, A., Gallagher, D., & Henry, S. (2007). E-marketing and SMEs: Operational Lessons for the Future. *European Business Review*, Vol. 19 Iss: 3, pp.234 - 247.
- [8] Gröne, F., Friedrich, R., Hölbling, K., & Peterson, M. (2009). The March of Mobile Marketing: New Chances for Consumer Companies, New Opportunities for Mobile Operators. *Journal of Advertising Research*, Vol. 49, No. 1, pp. 54-61.
- [9] Handayani, P.W., & Lisdianingrum, W. (2011). Impact Analysis on Free Online Marketing Using Social Network Facebook: Case Study SMEs in Indonesia. *Advanced Computer Science and Information System (ICACSIS)*, 2011 International Conference, ISBN:978-1-4577-1688-1, pp. 171 - 176.
- [10] Kaplan, A. (2012). If You Love Something, Let It Go Mobile: Mobile Marketing and Mobile Social Media 4x4 Found. *Business Horizons*, 55(2), 129-139 p. 130.
- [11] Litster, C. M. (2012). Why Mobile Marketing is Made for Small Business. <https://www.americanexpress.com/us/small-business/openforum/articles/why-mobile-marketing-is-made-for-small-business/>.
- [12] McNaught, K. (2014). Why SMEs Should be Using Mobile Marketing. <http://www.mobiledonky.com/blog/why-smes-should-be-using-mobile-marketing>.
- [13] McQuerrey, L. Differences Between Traditional Marketing Vs. Cyber Marketing. <http://smallbusiness.chron.com/differences-between-traditional-marketing-vs-cyber-marketing-49715.html>.
- [13] Meyer, M. H. (2007). The Fast Path to Corporate Growth: Leveraging Knowledge and Technologies to New Market Applications. *Oxford University Press*. ISBN 978-0195 180862, pp. 30.

- [14] Moth, D. (2014). 20+ stats that show the state of mobile marketing in China. <https://econsultancy.com/blog/65895-20-stats-that-show-the-state-of-mobile-marketing-in-china/>.
- [15] Raymond, P. (2012). Learning From Winners: How the ARF Ogilvy Award Winners Use Market Research to Create Advertising Success. ISBN 9781136676765, pp. 32–33.
- [16] Rouse, M. E-business (electronic business) is The Conduct of Business Processes on The Internet. <http://searchcio.techtarget.com/definition/e-business>.
- [17] Sabrina (2013) China Mobile Marketing Insights <http://www.chinainternetwatch.com/2823/china-mobile-marketing-insights/>.
- [18] Shankar, V., Venkatesh, A., Hofacker, C., & Naik, P. (2010). Mobile Marketing in the Retailing Environment: Current Insights and Future Research Avenues. *Journal of Interactive Marketing*, Volume 24, Issue 2, pp. 111–120.
- [19] Sheth, J. N., & Sharma, A. (2005). International E-marketing: Opportunities and Issues. *International Marketing Review*, Vol. 22 Iss: 6, pp.611 - 622
- [20] Siu, W. S., & Liu, Z. C. (2005). Marketing in Chinese Small and Medium Enterprises (SMEs): The State of the Art in a Chinese Socialist Economy. *Small Business Economics*, Volume 25, Issue 4, pp 333-346.
- [21] Stelzner, M. A. (2011). 2011 Social Media Marketing Industry Report: How Marketers are Using Social Media to Grow Their Businesses. [http://www.craigkunce.com/cdt/cdt\\_samples/oehtinger\\_barbara\\_sp2012.pdf](http://www.craigkunce.com/cdt/cdt_samples/oehtinger_barbara_sp2012.pdf).
- [22] Tang, H. (2015). [http://news.xinhuanet.com/comments/2015-03/03/c\\_1114500326.htm](http://news.xinhuanet.com/comments/2015-03/03/c_1114500326.htm).
- [24] Tanner, M. (2013). Wechat Marketing: Another Way to Reach China’s Affluent Consumers. <http://www.searchenginejournal.com/wechat-marketing-another-way-to-reach-chinas-affluent-consumers/62376/>.
- [25] Thoring, A. (2011). Corporate Tweeting: Analysing the Use of Twitter as a Marketing Tool by UK Trade Publishers. *Publishing Research Quarterly*, Volume 27, Issue 2, pp 141-158.
- [26] Current Mobile Marketing Trends. <http://www.retailtouchpoints.com/datapoints-of-the-week/1310-current-mobile-marketing-trends-infographic>, (2012).
- [27] Introduction to E-business. <http://toolkit.smallbiz.nsw.gov.au/part/27/138/647>
- [28] Mobile Marketing Statistics 2015. <http://www.smartinsights.com/mobile-marketing/mobile-marketing-analytics/mobile-marketing-statistics/>.
- [29] Nielsen-CCData. <http://www.adquan.com/post-8-29888.html>, (2015).
- [30] Seven top tips for understanding SMEs marketing budgets. <http://nrsmedia.com/resources/top-7-tips/understanding-smes-marketing-budgets-2/>, (2015).
- [31] Twitter via SMS FAQs. <https://support.twitter.com/articles/14014>, (2012).
- [32] Twitter.com Site Overview. <http://www.alexa.com/siteinfo/twitter.com>, (2015).
- [33] What is e-marketing and how is it better than traditional marketing? <https://www.quirk.biz/resources/88/2/What-is-eMarketing-and-how-is-it-better-than-traditional-marketing>, (2006).
- [34] Marketing Ideas For Small Businesses With Limited Budgets. <http://www.wordstream.com/blog/ws/2014/10/01/marketing-ideas-for-small-businesses>

## **USING SOCIAL LEGITIMACY THEORY TO UNDERSTAND THE LIKELY IMPACT OF DIGITAL DIRECT MARKETING ON WEB SALES**

Richard Heiens, Department of Business Administration, University of South Carolina Beaufort, One University Boulevard, Bluffton, SC 29909, 843-208-8231, richardh@uscb.edu  
Ravi Narayanaswamy, School of Business Administration, University of South Carolina Aiken, 471 University Parkway, Aiken, SC 29801, 803-641-3655, ravin@usca.edu

### **ABSTRACT**

The present manuscript examines digital direct marketing and the most common e-commerce digital sales channels. These digital sales channels include direct website visits, display ads, email, organic search, paid search, referrals, and social media. The theoretical mechanism that serves as the basis for the manuscript is social legitimacy theory. Specifically, the focus is on developing propositions regarding the likely effects of each digital sales channel on both perceived social legitimacy and potential Web sales performance. Although all digital sales channels may generate sales, it is proposed that display ads and paid search may negatively affect perceived social legitimacy.

Key words: digital sales channels, social legitimacy, web sales, e-commerce

### **INTRODUCTION**

While brick-and-mortar retailing has been on the decline, marketers have increasingly relied on digital direct marketing. However, the costs involved in designing and deploying effective digital sales channels are significantly high [27]. As a result, it is important to understand the benefits of allocating resources to build a firm's digital sales channels. As consumers flow through the digital environment, they inevitably leave an electronic signature that can potentially be traced by researchers, allowing marketers to collect and track various metrics associated with each digital sales channel. Hence, online retailers can potentially use this information to help allocate marketing budgets towards the most lucrative digital sales and marketing channels. Yet, much of the data is proprietary and very little publicly available research exists to date that could help fledgling online retailers identify which of these sources of retail traffic are associated with actual Web sales outcomes. In fact, there are no studies available in the academic literature to date that have examined the direct effect of these digital sales channels on actual sales performance. Instead, in the absence of sales data, most academic research has focused on variables such as conversion rates, purchase intentions, or even stock prices as proxies for sales [9a] [22] [33].

Given the lack of empirical results, future research studies are needed to help elucidate the relationship between digital direct marketing and sales. Therefore, in the current manuscript, we examine a handful of different digital sales channels, including direct



website traffic, display ads, email, both organic and paid search engine results, referrals from other sites, and social media. Furthermore, we examine these direct channels within the context of social legitimization theory. As suggested in previous research, perceptions regarding social legitimacy affect consumers' everyday lives, as legitimization is a micro-level phenomenon that occurs as individuals make sense of their world [5]. Considering the impact of digital media on this ongoing process, we examine the likely effectiveness of the various digital sales channels on the perceived social legitimacy of the firm, its products, and its messages. In addition, we present a series of propositions for future analysis and testing.

### **SOCIAL LEGITIMACY THEORY**

As articulated by others, "legitimacy is a generalized perception or assumption that the actions of an entity are desirable, proper, or appropriate within some socially constructed system of norms, values, beliefs, and definitions" [25, p. 574]. Legitimacy is a broad construct, and different researchers have found various categories of legitimacy through which individuals evaluate companies and consumption practices. While the generalized definition of legitimacy applies to them all, "each type of legitimacy rests on a somewhat different behavioral dynamic" [25, p. 577]. The concept of legitimacy was initially developed by researchers in the field of organizational behavior as a theoretical apparatus to address the dynamics which "constrain, construct and empower organizational actors" [25, p. 571]. Thus, the origin of the concept of legitimacy can be found within the realm of institutional theory. However, within the past decade, a handful of researchers have applied the concept of legitimacy with the purpose of addressing why consumers perceive certain brands or consumption practices as legitimate, but not others [13] [14] [16]. As a multilevel discourse-based construct, a wide range of media, communications methods, and authorities can be used as bases for legitimacy judgments [10]. As such, one can use the concept of legitimacy to gauge the authenticity and sincerity of all marketing communications, including both paid messages and naturally derived communications such as organic search results.

It has been suggested that social legitimacy occurs on three levels: regulative, normative, and cultural-cognitive [24]. Regulative legitimacy refers to the degree to which a practice conforms to the rules and regulations set forth by a superseding organization, such as the government. Irrespective of legal status, normative legitimacy can be thought of as the degree to which a particular practice is perceived to be congruent with fundamental norms and values. Finally, cognitive legitimacy can be defined as the degree to which the practice can be categorized and understood according to existing cognitive schemas and cultural frameworks [25]. As reasoned by previous researchers, cultural-cognitive legitimacy "occurs when consumers routinely inscribe frames on a brand with little reflective or critical thought" [16, p. 643]. In other words, practices or products imbued with cultural-cognitive legitimacy are so overwhelmingly accepted as integral components of the social fabric that they may even serve as standards or archetypes in the minds of consumers.

In a consumer context, we would expect consumers to judge a product or consumption practice as legitimate or illegitimate based on whether the product is assigned cultural-

cognitive legitimacy within the consumer's social group [31]. Cultural-cognitive legitimacy can be obtained through either explicit or implicit mechanisms. As described by previous research, "legitimation can occur through explicit mechanisms such as consumer reward or punishment" [13, p. 491]. In particular, if the product lives up to consumer expectations, it will likely be acknowledged as legitimate. In addition, and more commonly, legitimacy may also be obtained through implicit mechanisms. For example, if a brand is seen as an established artifact of daily life, it will quickly attain cultural-cognitive legitimacy [13]. Therefore, repeated exposures to the brand within a positive and socially desirable context will enhance its cognitive and cultural legitimacy. Considering the indispensable nature of mobile and online technologies to consumers' everyday lives, as well as the personal influence disseminated through this technology, we propose that the digital sales channel medium elevates the brand's social status so that it becomes capable of affirming one's social identity and bolstering one's sense of self-worth [31].

### **PROPOSITIONS**

Marketers are increasingly using new technologies to supplement and even replace their traditional communications channels. As with any innovation, organizations often struggle to successfully integrate new technologies within their established organizational structures, processes, and operations [32]. Yet, considering the growing influence of digital communications technologies, integrated marketing communications models need to be modified to consider these emerging tools. Collectively, (1) direct website traffic, (2) display ads, (3) email, (4) organic search engine results, (5) paid search engine results, (6) referrals from other sites, and (7) social media are responsible for the overwhelming majority of new ad spending [15]. While global advertising revenues grew by 7.2 percent in 2018 to reach a total of \$552 billion, digital media sales are forecast to represent nearly half of global ad dollars by 2020 at the latest [8]. Moreover, the shift from high cost media such as TV and newspapers to lower cost digital media has been taking place on a continuing basis since the early 2000s [21]. From the marketer's perspective, the introduction of these new, internet-based sales channels means that a larger customer base may become accessible and the marginal cost of reaching these customers may be negligible [3]. From the consumer's perspective, the choice to access one of these sales channels can be explained through the lens of social legitimacy theory.

#### **Direct traffic**

In a 2017 study of e-commerce, online consulting firm, SEMrush, noted that direct traffic to sites was the most significant website traffic source. Specifically, SEMrush found that 42.2 percent of overall traffic to e-commerce sites was generated by direct traffic. In comparison, only 3 percent was driven by social media [35]. The report went on to say that the relative dominance of direct traffic can be attributed to good brand awareness and brand loyalty. Consumers perceive the direct marketing channel as a viable purchase route with high utility. For that reason, they are often willing to forgo whatever benefits the traditional intermediaries provide in order to gain the resulting convenience and/or savings [4].

Having consciously and purposively chosen to access the site, these consumers represent a group of self-selected prospects with a high degree of engagement. In other words, consumers who choose to directly access a website have already accepted the social legitimacy of the marketer. Accordingly, we offer the first proposition.

- P1: The direct traffic sales channel will have a significant positive effect on both perceived social legitimacy and Web sales.

### **Displays ads**

Not every consumer begins their shopping process by logging directly onto a marketer's website. Advertising plays an important role as well. In the realm of digital advertising, display ads, also known as banner ads, are ads that appear on websites and offer a click-through option. These ad placements are most often negotiated on a pay-per-click basis. As with other forms of online advertising, display ads can be designed to target specific demographics, zip codes, or interests, commonly known as behavioral targeting. When a given ad is effectively calibrated to address a consumer's needs and interests, its social legitimacy is enhanced, leading users to click on the display ad. Subsequently, the consumer is sent to a specific landing page. For many online retailers, their landing page is a transactional website capable of generating direct sales.

However, recent research on the effectiveness of display ads suggests that click-through rates may be lower for repetitive display ads. Specifically, it has been demonstrated that click-through rates actually decrease as ad frequency and ad recency (the time interval between ad exposures) increase [6]. In addition, another study found that, in comparison to display ads, referrals are likely to be perceived as far more credible, calling into question the effectiveness of digital display advertising [1]. Consequently, we can expect a negative impact on perceived social legitimacy. However, display advertising may still drive sales by other mechanisms such as enhancing brand awareness or stimulating unplanned purchases. Consequently, we offer the second proposition.

- P2: The display ads sales channel will have a significant negative effect on perceived social legitimacy but a significant positive effect on Web sales.

### **Email**

Email marketing involves both advertising and promotional materials delivered to prospective customers through email messages. In the early days of ecommerce, many online retailers relied on registration and cookie technology to target visitors with promotional emails [11]. Despite the development of newer digital marketing technologies, email remains an important part of the marketing mix for online retailers. Research shows that the majority of the largest online retailers still rely heavily on email. In fact, fully 70 percent of online retailers employ email marketing [19]. Moreover, it has been shown that larger retailers send more emails per customer per year than their smaller rivals [12]. This is because, in addition to their low cost, one important advantage of email marketing is that

the content of emails can be optimized through testing and analysis to maximize effectiveness.

According to previous research, sharing of essential resources such as information and experiences strengthens the cultural norms and values of the brand [10]. Hence, email marketing is a promotional method capable of enhancing perceived social legitimacy. In addition, it has been estimated that email provides twice the return on investment relative to other forms of online marketing [19]. Thus, email is also capable of driving sales outcomes. This leads to the third proposition.

P3: The email sales channel will have a significant positive effect on both perceived social legitimacy and Web sales.

### **Organic Search**

Information seeking consumers widely use search engines, making this one of the most popular activities on the Internet [28]. Indeed, the share of U.S. online adults who conduct searches on their mobile phones at least once a week increased from 38 percent in 2013 to 57 percent in 2017 [23]. Search results can be divided into two categories, organic and paid. Organic rankings of advertisers' websites in response to consumer search activities are based on complex and proprietary algorithms devised by the search engine. There is some evidence to suggest that, due to the perceived "editorial integrity" of organic listings, consumers have a positive bias towards these organic search results [34]. Because of this, when consumers follow an organic search outcome to a marketer's website, it is likely that the organic search sales channel has had a significant positive effect on perceived social legitimacy. In addition, they are also likely to be positively predisposed towards that marketer's goods and services, which drives sales. This leads to the fourth proposition.

P4: The organic search sales channel will have a significant positive effect on both perceived social legitimacy and Web sales.

### **Paid Search**

In addition to a list of organic results, consumers also receive paid search results in response to their search queries. However, consumers tend to question the sincerity and integrity of these paid search listings [34]. This is unfortunate because the legitimacy of brands is contested in online communities every day [10]. Therefore, the use of paid messages with questionable credibility can potentially lead to a significant negative impact on perceived social legitimacy.

Nevertheless, in the case of all search outcomes, including paid search results, the information provided to consumers is directly determined by the consumers' search keywords [17]. As a result, despite their relatively lower trustworthiness in comparison to organic search results, paid search results are still likely to be of direct relevance to consumers. Therefore, they are also still likely to be capable of driving sales outcomes. This leads to the fifth proposition.

- P5: The paid search sales channel will have a significant negative effect on perceived social legitimacy but a significant positive effect on Web sales.

### **Referrals**

In online retailing, website referrals occur when people are prompted to click on hyperlinks or related content on other sites. This strategy represents a low-cost acquisition strategy that offers the opportunity to attract high-quality new customers. Firms prompt referrals through both inbound and outbound mechanisms [1]. Inbound mechanisms include tactics such as hosting a “refer a friend” link on the company webpage. Out-bound referral mechanisms include suggesting third party sites to proactively pass on information in the hopes that it will attract consumers to the marketer’s landing page. In recent years, referrals have become a significant source of website traffic. In fact, one recent report indicates that referrals are responsible for 35 percent of all traffic [30]. Moreover, the percentages are even greater for mobile web [29].

Cognitive legitimacy reflects assumptions regarding the degree to which “an individual’s social environment accepts the consumption of a certain product or service as necessary” [9, p. 539]. Considering the ability of referrals to reinforce this assumption, they are certainly likely to have positive implications for the social legitimization of the firm and its message. Not surprisingly, referrals have become crucial to retailers’ digital strategies. Considering the likely role of website referrals in enhancing perceived social legitimacy and driving sales, we offer the sixth proposition.

- P6: The referrals sales channel will have a significant positive effect on both perceived social legitimacy and Web sales.

### **Social media**

Finally, social media enable consumers to instantly share their purchase decisions with their friends, family, and acquaintances. Accordingly, firms are increasingly seeking to capitalize on these online social networks to compensate for the decreasing effectiveness of traditional influence such as mass media advertising [22]. This is a wise decision, as research reveals that consumers spend more time engaging in social networks than any other online activity [2]. The largest social channel is Facebook, and most Facebook ads today consist of stand-alone video within the news feed [23]. It has been suggested that consumers consider information they obtain from social media to be more trustworthy than marketing messages received through traditional channels [7]. Thus, we can expect this sales channel to significantly enhance social legitimacy perceptions. Also, because consumers are so actively engaged with social media, it is also likely to yield positive sales outcomes. This leads us to our final proposition.

- P7: The social media sales channel will have a significant positive effect on both perceived social legitimacy and Web sales.

## **DISCUSSION AND POTENTIAL IMPLICATIONS**

Traditional brick-and-mortar retailers have long focused their marketing efforts on increasing store traffic. This is because, if they have the human resources and the physical store space necessary to convert these prospects into customers, the result is an increase in sales volume and, ultimately, store profits. Unfortunately, evidence suggests that physical retailers typically contend with labor limitations and consumer perceptions of store crowding. Consequently, sales volume often exhibits diminishing returns to scale with respect to store traffic [20]. However, online retailers don't face these limitations. Instead, as long as they can generate traffic to their websites and convert those visitors to customers, there are few limits on increasing their sales. In addition, if online retailers can identify the source of website traffic that is associated with the highest sales results, they can maximize both the efficiency and the effectiveness of their marketing efforts. Therefore, through the use of actual digital sales channel traffic and Web sales data, researchers may be able to identify valuable findings for practitioners and theorists alike.

The proposed analyses are important to study in the future because the link between digital sales channels and Web sales has not always been clear in the past. For instance, it has been noted that online retailers have been largely unable to quantify the return on investment in social media. For example, one industry study reported that 59% of retailers believe that the returns from social media are unclear [18]. One possible explanation for the lack of clarity regarding the effectiveness of social media as well as other digital direct sales channels may be due to the widespread use of proxy variables to measure outcomes. Without analyzing sales results, any examination of the effectiveness of a firm's marketing efforts is bound to be inconclusive.

It may not be necessary for practitioners to simultaneously invest in each of the digital sales channels. In fact, doing so may actually be redundant and possibly lead to diminishing returns. Therefore, when constrained by limited resources, an online retailer may choose to eliminate digital sales channels that could prove to be superfluous. Therefore, from a practitioner viewpoint especially, determining the veracity of our propositions could provide important insight when it comes to making critical decisions on prioritizing marketing budgets. Nevertheless, it is important for online retailers to contemplate factors such as sales channel compatibility with product attributes or target market considerations when making such adjustments.

Finally, future studies may seek to examine additional variables not included in our propositions. For example, conversion rates can also be examined alongside sales results. Also, we can expect even newer technologies such as 360-degree video, augmented reality, and virtual reality to emerge in the future, providing additional opportunities and challenges for marketers [23]. As a result, studies may need to be replicated regularly, as future consumers may choose to access transactional websites from an even wider range of digital sales channels.

## **REFERENCES**

- [1] Ahrens, J., Coyle, R.J., & Strhilevitz, A.M., (2012) 'Electronic word of mouth: The effects of incentives on e-referrals by senders and receivers', *European Journal of Marketing*, 47(7), 1034-1051.
- [2] Biucky, S.T., Abdolvand, N., & Harandi, S.R. (2017) 'The effects of perceived risk on social commerce adoption based on the Tam model', *International Journal of Electronic Commerce Studies*, 8(2), 124-147.
- [3] Cattani, K., Gilland, W., Heese, H.S., & Swaminathan, J. (2006) 'Boiling frogs: Pricing strategies for a manufacturer adding a direct channel that competes with the traditional channel,' *Production and Operations Management*, 15(1), 40-56.
- [4] Chiang, K.W., Chhajed, D., & Hess, D.J., (2003) 'Direct marketing, indirect profits: A strategy analysis of dual-channel supply-chain design,' *Management Science*, 49(1), 1-20.
- [5] Coskuner-Balli, G. (2013) 'Market practices of legitimization: Insights from consumer culture theory', *Marketing Theory*, 13(2), 193-211.
- [6] Försch, S. & de Hann, E. (2018) 'Targeting online display ads: Choosing their frequency and spacing', *International Journal of Research in Marketing*, 35(4), 661-672.
- [7] Foux, G. (2006) 'Consumer-generated Media: Get Your Customers Involved', *Brand Strategy* 8, 38-9.
- [8] Graham, M. (2018) 'Forecasters temper ad spending estimates: Digital spend predicted to hit a milestone', *Advertising Age*, 89(24), 6.
- [9] Gudigantala, N., Bicen, P., & Eom, M. (2016) 'An examination of antecedents of conversion rates of e-commerce retailers', *Management Research Review*, 39(1), 82-114.
- [10] Hakala, H., Niemi, L., & Kohtamäki, M. (2017) 'Online brand community practices and the construction of brand legitimacy', *Marketing Theory*, 17(4), 537-558.
- [11] Hansotia, B. J. & Rukstales, B. (2002) 'Direct marketing for multichannel retailers: Issues, challenges, and solutions', *Journal of Database Marketing*, 9(3), 259-266.
- [12] Heiens, R. A. & Narayanaswamy, R. (2016) 'An examination of the e-mail and electronic relationship marketing practices of the USA's top 500 online retailers', *International Journal of Electronic Customer Relationship Management*, 10(2), 125-137.
- [13] Humphreys, A. (2010), "Semiotic Structure and the Legitimation of Consumption Practices: The Case of Casino Gambling," *Journal of Consumer Research*, 37(October), 490-510.

- [14] Humphreys, A. & Latour, K.A. (2013) Framing the Game: Assessing the Impact of Cultural Representations on Consumer Perceptions of Legitimacy, *Journal of Consumer Research*, 40(4), 773-795.
- [15] Internet Retailer (2018) 'The year ahead: The trends and key developments retailers can expect to encounter in 2019. Digital E-commerce,' accessed July 6, 2019, available at <http://www.digitalcommerce360.com/IR>.
- [16] Kates, S. M. (2005) , "The Legitimate Brand", in NA - Advances in Consumer Research Volume 32, eds. Geeta Menon and Akshay R. Rao, Duluth, MN : Association for Consumer Research, 643-643.
- [17] Liu-Thompkins, Y. (2019) 'A decade of online advertising research: What we learned and what we need to know', *Journal of Advertising*, 48(February), 1-14.
- [18] Mulpuru, S., Harteveltdt, H. H., & Roberge, D. (2011) 'Five retail e-commerce trends to watch in 2011', *Forrester Research Report*, (January 31).
- [19] Pavlov, V. O., Melville, N. & Plice, R.K. (2008) 'Toward a sustainable email marketing infrastructure,' *Journal of Business Research*, 61, 1191-1199.
- [20] Perdikaki, O., Kesavan, S., & Swaminathan, J.M. (2012) 'Effect of traffic on sales and conversion rates of retail stores', *Manufacturing and Service Operations Management*, 14(1), 145-163.
- [21] PR Newswire (2016) 'Internet Advertisement to grow 11.22% during the period 2016-2020', *PR Newswire US*, 8 September, accessed June 17, 2019, available at <https://www.prnewswire.com/news-releases/internet-advertisement-to-grow-1122-during-the-period-2016-2020-300325198.html>.
- [22] Risselada, H., Verhoef, P. C., & Bijmolt, T. H. A. (2014) 'Dynamic effects of social influence and direct marketing on the adoption of high-technology products', *Journal of Marketing*, 78(2), 52-68.
- [23] Rowe, S. D. (2018) 'Mobile ad spending to continue gains: Video will be a major factor in mobile ad spending growth, Forrester Research finds', *CRM Magazine*, 7, 18.
- [24] Scott, W. R. (1995) *Institutions and Organizations*, Newbury Park, CA: Sage.
- [25] Suchman, M. (1995), "Managing Legitimacy: Strategic and Institutional Approaches," *Academy of Management Review*, 20(3), 571-611.
- [26] Slovic, P., Finucane, M., Peters, E., & MacGregor, D. G., (2002) 'Rational actors or rational fools: implications of the affect heuristic for behavioral economics', *Journal of Socio-Economics*, 31(4), 329-342.



- [27] Sohrabi, B., Mahmoudian, P., & Raessi, I. (2012) 'A framework for improving e-commerce websites' usability using a hybrid genetic algorithm and neural network system', *Neural Computing and Applications*, 21(5), 1017–1029.
- [28] Stephens, M., Yoo, J., Mourao, R. R., Vu, H. T., Baresch, B., & Johnson, T. J. (2014) 'How app are people to use smartphones, search engines, and social media for news?: Examining information acquisition tools and their influence on political knowledge and voting', *Journal of Information Technology and Politics*, 11(4), 383–396.
- [29] Strugatz, R. (2017) 'The power of influencer referrals: Four out of every five of Nordstrom's mobile Web visits come from referral traffic driven by an influencer', *WWD: Women's Wear Daily*, accessed July 8, 2019, available at <https://wwd.com/business-news/retail/influencers-chriselle-lim-man-repeller-leandra-medine-reward-style-drive-traffic-and-sales-10994073/>.
- [30] Tomoe, R. (2019) 'Asking for directions: Is there a way for publishers to predict referral web traffic?', *Editor and Publisher*, 152(4), 24-25.
- [31] Tost, L. (2011), "An integrative model of legitimacy judgments," *Academy of Management Review*, 36(4), 686-710.
- [32] Valos, M. J., Maplestone, V. L., Polonsky, M. J., & Ewing, M. (2017) 'Integrating social media within an integrated marketing communication decision-making framework', *Journal of Marketing Management*, 33(17/18), 1522–1558.
- [33] Van Slyke, C., Belanger, F., & Comunale, C. L. (2009) 'A behavioral beliefs model of trustworthiness in consumer oriented e-commerce', *Journal of Electronic Commerce in Organizations*, 7(2), 22-43.
- [34] Yang, S. & Ghose, A. (2010) 'Analyzing the relationship between organic and sponsored search advertising: Positive, negative, or zero interdependence?', *Marketing Science*, 29(4), 602-623.
- [35] Zaczekiewicz, A. (2017) 'Direct traffic rules global e-commerce', *WWD: Women's Wear Daily*, accessed June 20, 2019, available at <https://wwd.com/business-news/retail/semrush-ecommerce-study-11082007/>.

## **USING THE ARTIFICIAL NEURAL NETWORK FOR PREDICTING PERCEIVED RISK IN FINANCIAL SERVICES**

Komlan Gbongli,

Institute of Finance and Accounting, Faculty of Economics, University of Miskolc, 3515 Miskolc-Egyetemvaros, Hungary, samxp12@yahoo.fr / pzkgbong@uni-miskolc.hu

Anthony Adu Amponsah

Faculty of Economics, University of Miskolc, 3515 Miskolc-Egyetemvaros, Hungary, anthonyamponsah13@gmail.com

### **ABSTRACT**

This study intends to offer an integrated Structural Equation Modeling (SEM) - Artificial Neural Network (ANN) technique for evaluating the perceived risk factors affecting mobile money adoption services in the context of Togolese financial services. This research proposes determinants such as privacy risk, time risk, security risk, and perceived cost. The data collected from both mobile money users and potential users were analyzed using SEM, and ANN approaches.

This study extends previous research in several directions. The results of SEM showed that privacy risk perceived, security risk perceived, and cost perceived exercised significant effect on the aggregate perception of risk for mobile money acceptance and usage. The SEM results were taken as inputs for the ANN approach. The results of ANN emphasized that perceived privacy risk is the most critical determinant for mobile money adoption amongst the respondents.

The primary outcomes of this study revealed that the application of a two-step SEM-ANN approach offers two significant advantages: First, it allows additional verification of the results derived from the SEM analysis. Second, this approach enables apprehending not only linear but also complex nonlinear relationships between antecedents and dependent constructs, particularly measuring of the relative influence of each predictor.

The ANN-based SEM technique could be superior to traditional SEM techniques due to its ability to measure non-linear relations by using different activation functions and layers of hidden nodes. The outcome of the integrated approach is projected to guide the decision and policy-makers for easy evaluation of the various type of risk affecting consumers for choosing mobile money services.

**Keywords:** Mobile Financial Services, Consumer Behavior, Structural Equation Modeling (SEM), Artificial Neural Network (ANN).

THE REMAINING PART OF THE PAPER WILL BE PRESENTED DURING THE CONFERENCE.

**Student Papers  
(Undergraduate, Master  
and Ph.D Students) -  
Abstracts**

# **An Analysis of Benign and Malignant Tumors: A Machine-Learning Model**

---

Regular Session

---

*Ms . Karina Kostova <sup>1</sup>, Ms . Allyson Leshner <sup>1</sup>*

*1. College of Charleston*

In this paper, we will be analyzing data collected by researchers in an effort to create a machine-learning model that will identify whether a tumor is cancerous or benign and does not require surgical intervention.

# Applying Kahoot.com in Operations Management Class

---

Regular Session

---

***Mrs . Huiling Liu*** <sup>1</sup>

*1. Georgia Southern University*

Technology development has changed the learning environment dramatically. Not only have technology tools such as PowerPoint, Video, Folio, Email, etc. become popular in classroom, but also the new generation learners who grow up in a world embedded with technology like flexible and interactive learning environment. Under this circumstance, traditional teaching method such as visual and verbal explanation may not be effective anymore. New teaching methods are required. Is there a new teaching method that can effectively encourage learning and thus improve learning outcomes in new learning environment? This study aims to answer this question through an experiment study. We propose that the application of Kahoot.com in teaching can provide flexible and interactive learning environment to students and thus significantly improve students' learning outcomes. Kahoot.com is a game-based learning platform designed to assist instructors improve their teaching effectiveness and help students to achieve high level learning outcomes. Instructors can create various learning games, "kahoots", which are comprised of questions, practices, and quizzes in different forms, for their courses. Students who obtain PIN from their instructors can play these games either by participating 'individual to individual' games or 'team to team' games during or after class. Based on theory of gamified learning, we believe that the application of Kahoot.com in teaching can positively influence students' attitude of learning, willingness to devote to class, and learning outcomes. We plan to conduct an experiment study in the course of "Operations Management" in Georgia Southern University to estimate the proposed effects. Survey will be designed to estimate students' attitudes and willingness to devote to class.

# Effect of a diverse corporate board structure on operational performance in dynamic environments

---

Regular Session

---

***Ms . Lakshmi Madarasu*** <sup>1</sup>

*1. Georgia Southern*

The relationship between environmental dynamism in an industry and the operational performance of an organization has been widely explored in operations management research. Evidence from previous research in operations management shows that environmental dynamism in an industry negatively affects the operational performance of a firm. The purpose of this paper is to investigate whether a diverse board structure significantly moderates the relationship between environmental dynamism and the operational performance of a firm using the theoretical lens of dynamic capabilities theory. Dynamic capabilities theory states that dynamic capabilities of a firm refer to the firm's ability to reconfigure its strategy, to build, integrate and reconstruct internal and external resources to achieve sustainable competitive advantages and attain superior performance in rapidly changing environments. Dynamic capabilities act as buffers between a firm's resources and the dynamically changing business environment to increase firm performance and thereby help a firm sustain its competitive advantage. Dynamic capabilities of a firm are unique to the firm, are path dependent and emphasize on resource development and resource renewal. The novelty of this paper is in determining how the number of women directors in a corporate board and the board of directors' age range negatively moderate the effect of environmental dynamism on operational performance for U.S. manufacturing firms, thereby improving the operational performance of the manufacturing firm. This model will be analyzed using secondary data for U.S. firms from 1990 to 2018 using simultaneous equation modelling technique. The results will refine our understanding of what makes a diverse corporate board effective in a dynamic environment in the U.S. manufacturing industry.

**Keywords:** *Board gender diversity, Board of directors' age range, Environmental Dynamism, Operational Performance*

## How health behaviors affect the academic performance?

---

Poster

---

*Ms . Abigail Wostbrock <sup>1</sup>, Ms . Anna Zheng <sup>1</sup>, Ms . Sarah Douress <sup>1</sup>, Mr . Noah McLemore <sup>1</sup>, Dr . Helen You <sup>1</sup>*

*1. James Madison University*

Student health behaviors reflect a broad pattern that affects students' study life and academic performance. It creates an environment, either healthy or unhealthy, that in turn affects other students as well. With first-hand survey data from James Madison University students, this study examines the effects of health behaviors and socio-demographics on students' academic performance, as measured by their grade point average (GPA). We found that white young adults had relatively better performance averages when compared to other ethnic groups. This pattern was the same for both males and females. Student smokers were found to have lower GPA than nonsmokers, student athletes to have lower GPA than non-athletes, and drinkers to have lower GPA than nondrinkers, while not significantly. As expected, we found that students enrolled in more credit hours are associated with a higher GPA and statistically significant. This may be because students who perform better academically tend to register for more credit hours. This study helps students better understand the factors that affect their academic performance. It provides students with insight that findings may or may not be consistent with an original hypothesis.

---

# IMPACT OF ORGANIZATIONAL CULTURE ON ENVIRONMENTAL PERFORMANCE OF FIRMS

---

Regular Session

---

***Ms . Senali Amarasuriya <sup>1</sup>, Dr . Deepak Iyengar <sup>1</sup>, Prof . Rahul Nilakantan <sup>2</sup>***

*1. Parker College of Business, Georgia Southern University, Statesboro, GA 30460 , 2. Indian Institute of Management Indore*

There is an increasing concern about the environmental degradation due to economic growth of firms, where increased economic activity is perceived to be linked to more environmental damage. Extant literature connects national culture with environmental performance at the country level, using Hofstede cultural scores. Other studies have looked at the impact of national culture on the social and environmental performance of companies (measured as a value of each firm's intangible capital) around the world. Prior literature has also conceptualized the link between organizational culture and corporate sustainability, using the competing values framework. Past studies have used the Hofstede's cultural score and /or GLOBE cultural factors in linking culture to environmental performance at the unit of analysis of a country. This research addresses the gap in literature of studying the impact of organizational culture on environmental performance at the firm level. Also, this study uses the GLOBE cultural factors instead of the Hofstede cultural factors, due to their high validity. The four dimensions of GLOBE cultural factors that this study uses are Performance Orientation, Assertiveness, In-Group Collectivism and Gender Egalitarianism. Some of the dimensions of environmental performance that this study looks at are material and energy consumption, resource conservation, toxin reduction and remediation, environmental education, water usage, waste reduction programs, suppliers and transportation etc. This study is in the process of collecting empirical data to analyze the relationship between organizational culture and environmental performance. The results of the study would be used to indicate how cultural orientation of organizations link to the environmental performance of organizations, thereby answering the question as to why operations of some organizations are more environmentally sustainable than others.

*Keywords: environmental performance, GLOBE cultural factors, cultural orientation*



# Increasing the environmental transparency of the coffee supply chain using blockchain for carbon tracking and package labeling

---

Regular Session

---

*Ms . Mya Belden* <sup>1</sup>

*1. College of Charleston*

The coffee supply chain consists of many resource inputs; a farmer, picker, washer, dryer, huller, roaster, sorter, packager, shipper, distributor, and consumer. At each stage of the supply chain, carbon equivalents represent an important output, one that should largely be considered and measured as climate change mitigation efforts become an imperative. However, there is an opportunity within coffee supply chains for carbon sequestration, which decreases the overall carbon footprint of the product and even allows for the process to retain more carbon than it emits. Blockchain, a distributed ledger technology, can be used to capture and store this data in a decentralized and highly secure way each time a transaction is made. The carbon equivalents data stored in the blockchain can be used to create labels to inform consumers of the environmental impacts of their purchase at the decision making point. This paper investigated the transparency and traceability of coffee production by quantifying carbon equivalents at each node of the supply chain through the empirical implementation of blockchain technology. Blockchain is an important tool in making supply chains transparent in that it is trustworthy, immutable and mature enough to produce such complex environmental metrics. These outputs can then be displayed on a label to inform consumers about the externalities of their purchase at the decision making point. It is a quality solution to impending regulatory and consumer demand, will allow for an increase in corporate accountability, and will be an essential tool in redefining stakeholder value. A permissioned blockchain model was developed for an exemplar coffee supply chain to store carbon equivalents data through smart contracts. The model was empirically tested in Amazon Web Services through hyperledger fabric. The results show that it is possible to use blockchain and that it is mature enough to be used as the new storage technology for independent participants throughout the supply chain. The capabilities of blockchain align directly with the needs of supply chain systems where participants are independent from one another and would allow them to preserve the integrity of the data they exchange without relying on a centralized authority to provide the trust mechanism, such as in relational databases. The utility of data stored in the blockchain can be used to generate consumer labeling to make supply chain data transparent and consumable to the consumer, whose satisfaction is the ultimate goal of supply chain management.

# INTEGRATING BLOCKCHAIN TECHNOLOGY WITHIN THE LOWE'S COMPANY INC. TO ENHANCE TRACEABILITY AND VERIFY WOOD CERTIFICATION ALONG THE SUPPLY CHAIN

---

Regular Session

---

***Ms . Taylor Miller*** <sup>1</sup>

*1. College of Charleston*

Corporate sustainability is becoming more attractive and necessary as companies strive to improve their long-term economic development by merging responsibility and profit. One technique sustainability-oriented companies have been employing is enhancing traceability within their supply chains. Scholars and supply chain managers believe that blockchain technology can benefit and help in enhancing green supply chain management. This work is focused on developing a wood traceability method that integrates blockchain technology within the Lowe's Company in order to enhance traceability and verify certification of wood along the supply chain. This project will investigate can wood be accurately tracked throughout the supply chain to ensure certification integrity.

# Investigating the Financial Literacy of College Students

---

Regular Session

---

*Ms . Jamie Obremski <sup>1</sup>*

*1. Roanoke College*

College can be a difficult transition for any student. Living on your own for the first time, deciding on a career path, and a whole new world of responsibilities just scratches the surface of the many challenges a new college student will face. One of the biggest gaps experienced by college students is financial knowledge and responsibility. The majority of students are beginning to take more control over their personal finances and lack the skill and knowledge to make responsible financial decisions. The focus of my distinction project is measuring the financial literacy, or lack thereof, of Roanoke College students and determining ways to lessen this gap. Through research on prior academic work in this area three primary topics were chosen to create a module administered in a one-hour block during the week of freshman orientation. This goal of this module was to increase students' knowledge in this field and aid in becoming more financially responsible. A survey that was administered at the beginning of the session was also created with two sections: background information and budgeting/credit knowledgeA . Background information was collected to determine the student's gauge of their own financial understanding. The second section asked some basic questions regarding budgeting and credit to later compare these answers with a post-survey in order to see if the session was successful in improving their knowledge in these subjects. Following the module session we sent out a post-survey around 5 weeks later that replaced the background information in the first survey with questions regarding their reaction to the session. The second section that tested knowledge on budgeting/credit information was the same as the original surveyB. The purpose of this was to compare the responses before and after the module session to see if there was any improvement after being formally introduced to the information. The response section also allowed us more insight as to how the information was received and what other information students wished to know more about. A second session was scheduled for mid-November in order to gather more information and reach a greater number of freshman. Following the second session all of the data will be analyzed and gathered into a format that can be visually presented to an audience. The final result will consist of an academic paper that will compile the results of my research and literature review that I have completed. In the future, the hope is that schools will be able to provide assistance to incoming students to enable them to be prepared for the financial responsibility that is required of them for the rest of their life.

# Is Agriculture a Sustainable Form of Income for Mid-Sized Farms in the Southeastern United States?

---

Regular Session

---

*Ms . Ashley Gandy <sup>1</sup>, Mr . Carson Ward <sup>1</sup>, Dr . David Franck <sup>1</sup>*

*1. Francis Marion University*

Production of agriculture is a pillar of our economy that allows for us to keep advancing. Therefore, understanding how and why the agricultural landscape is changing is important for our advancement. Farm consolidation, an aging workforce, access to new technology, and diminished traditional mid-sized farmers in importance are significant trends. As farming transitions to a more corporate, large scale industry model, it is important to examine the causes and consequences of these changes. Our study examines several factors and attempts to address the question: “Is agriculture a self-sustainable form of income for mid-sized farms in Southeastern United States?”

The United States Department of Agriculture (USDA) data provides a cost breakdown and net income before government assistance or insurance payments are configured into the producer’s overall operation.

The US Census of Agriculture (2017) indicates the typical producer is a white male with an average size farm of 441 acres. This excludes many farmers from being qualified to participate in these aid programs to get extra assistance during financially stressful months.

Additionally, the rising average age of farmers is a concern. Roughly one-third of current farmers in the United States are 65 years or older and 36% are 65 or older in South Carolina. The average age range for a farmer is 55-64. As this age increases, concern for the aging workforce is gaining traction (United States Census of Agriculture, 2017).

A trend of farm consolidation indicates Middle-size traditional farmers appear to be financially vulnerable and under distress. The majority of these farmers’ household income is by other revenue streams. While there is an increase in efficiency with technological advancement, many midsize farmers cannot afford this new technology and may become obsolete and forced to leave the industry (Most Farmers Receive, 2018). Other common trends include increased capital costs and a scarcity of labor. Income in agriculture can also vary due to factors such as futures markets, commodity prices, weather, changes in each Farm Bill, new cash crops, and an increase in organic farming.

In this paper, we analyze data to describe why these farmers are forced to be resourceful and how they are resourceful to maintaining their livelihood. To measure this, we compare nationwide averages to local, regional or state data. From there, we look at FSA and the most recent Farm Bills to note monetary allocation for producer aid. We also examine widespread trends in the industry.

# Maximizing The Use of Resources at Anderson Interfaith Ministries Through the Optimization Capabilities of Linear Programming

---

Regular Session

---

*Ms . Lorraine Haselden<sup>1</sup>, Ms . Autumn Shaw<sup>2</sup>*

*1. anderson , 2. Anderson University*

The objective of this research paper is to show the use of linear programming to optimize the fundraising operations at Anderson Interfaith Ministries (AIM) through the maximization of resources. AIM is a local food bank and non-profit that serves to meet the needs of the people in the Anderson, SC area. They have several annual events that are used to raise funds for their ministry and operations. This project seeks to use linear programming to maximize the use of their fundraising capabilities to provide the optimal mix of events that will benefit the ministry the most. In the past year, AIM was able to financially assist 422 families with \$73,947 of collected charitable donations.

# Operational Capability Trade-offs and Market Survival

---

Regular Session

---

***Mr . Ata Karbasi Kheyr*** <sup>1</sup>

*1. Georgia Southern University*

There is empirical evidence that an incumbent would respond to competitors' attacks on its market by adjusting marketing mix variables. Despite the widespread occurrence of market entry and exit, the dynamics of such phenomena are complex and still poorly understood. Several studies have identified that market-specific characteristics are critical features of firms' survival in a market. However, there are a few studies in the literature that takes the operational characteristics of the firms into account. Combining the concept of market survival with the notion of the operational capabilities of a firm, the effect of the incumbent's operational trade-off on the newcomer's survival in the context of the airline industry was empirically assessed. Particularly, I analyze how adopting an operational capability strategy would affect the incumbent survival and new entrant's exit likelihood in a market. To test the hypothesis, a unique route level data set that combines airlines' network characteristics, flight service quality, flight fare with airports, and the market level data is assembled. It is expected that there is a need to consider market-based operational capabilities when applying any market defense strategy and offer prescriptions for managers on how to protect their markets more effectively by applying appropriate operational strategies. This study provides a new insight for academics and managers regarding the impact of the incumbent's operational capability trade-offs on their market survival and the likelihood of a new entrant's exit likelihood. It makes significant contributions to the marketing and operations management literature. Moreover, the managerial implication of this paper is that well-established incumbent firms should be cautious in the implementation of their operational capability trade-offs to the market entry and exit.

# Optimizing School Bus Stops Using Clustering Methods

---

Regular Session

---

***Mr . Ian Dors*** <sup>1</sup>

*1. Christopher Newport Univesity*

The goal of this research project is to optimize the procedure of creating school bus stops and assigning students to them. In many US counties, the beginning of the academic year in public schools is associated with substantial preparatory work. One of these activities is deciding where the bus stops will be located and which students will be assigned to each bus stop. In the vast majority of counties, this labor-intensive task is done manually and therefore, often results in a sub-optimal distribution of bus stops. If too many bus stops are created with too few students assigned to them, then this will result in the scheduling of additional bus routes to pick up school students, as bus routes will take too much time. In this case, the county Office of Transportation will need to spend additional funds for more buses, hiring drivers, gas, and maintenance. The focus of this research, therefore, is two-fold: (a) automate the task of creating bus stops and assigning students to them, and (b) minimize the total number of stops required, resulting in fewer bus routes. The project goals will be addressed by utilizing clustering algorithms, which will allow the grouping of students who live close by each other and assigning a bus stop for them. When the clustering technique is developed, the second part of this project will be to implement this proposed algorithm in software using a combination of Python and JavaScript.

# Personal Wellness: An Empirical Study of the Ramifications of Overusing Instagram

---

Regular Session

---

*Ms . Amber Gregory <sup>1</sup>, Mr . benjamin hamilton <sup>1</sup>, Ms . Alexandra Wolfe <sup>1</sup>*

*1. Roanoke College*

Instagram is a rapidly growing social media hub. With this growth, there is a concern that using this social media giant is causing an increase in a user's depression, anxiety, the tendency of eating disorders, and a decrease in self-confidence. The growth is concerning because the more people that use Instagram, the more these mental health concerns increase. The researchers examine the problems of frequently using Instagram by surveying 116 college students at a small liberal arts institution. The data collected demonstrated that if college students use Instagram more, then they have poor personal wellness in relation to eating disorders, depression, and self-confidence. Further, our research points to evidence of a cyclical relationship between depression and Instagram use, mainly that the more one uses Instagram the worse they felt, which caused them to use it even more. Anxiety was insignificant in relation to Instagram use. This research sheds light on the growing problem of decreased personal wellness and its relationship to Instagram use. More research is required on this topic to investigate how depression and the tendency of eating disorders can influence Instagram use.



# Resource Orchestration: Costs and Risk Implications

---

Regular Session

---

***Ms . Melanie Hinterplattner*** <sup>1</sup>

*1. Georgia Southern University; University of Applied Sciences Upper Austria - Logistikum*

Although a growing amount of literature highlights the importance of effective resource orchestration, little is known about the costs associated with adjusting the firm's resource base and its risk implications. Resource adjustments are necessary to stay competitive and, in best case, increase the firm's market value. They are, however, not costless and can expose firms to risk. It is therefore critical to understand what resource adjustments (expressed in adjustment costs) bear what risk. In this paper, we examine the relationship between resource adjustment costs and a firm's downside risk, i.e. the risk of below target performance. Analyzing a large secondary data sample of 7,439 US firms, we seek to find support for our hypothesis that there exists an inverse U-shaped relationship between adjustment costs and downside risk, with the highest risk occurring at a medium level of adjustment costs.

# Retail Optimization for Habitat for Humanity's ReStore

---

Regular Session

---

***Mr . Christopher White <sup>1</sup>, Mr . Marquis King <sup>1</sup>, Ms . Adrianna Roulhac <sup>1</sup>***

*1. Fayetteville State University*

With all of the challenges brick and mortar stores face with the competition of other stores, choosing an efficient product layout should be a top priority. The problem with many retail stores is their product layout. Without an optimized layout the store will not have a proper flow, causing the layout to be confusing and in turn customers to struggle finding the product they are looking for. The primary focus for this study was Habitat for Humanity's ReStore. This ReStore location consisted of countless departments that were scattered randomly throughout the store. The store was unorganized, cluttered and needed an interior re-organization in order to improve sales and profitability. The study we performed consisted of measuring the entire store, labeling, measuring and calculating revenue per square foot of each department. The data we collected was entered into a modeling system known as General Algebraic Modeling System (GAMS). With the use of formulas and modeling systems, we were able to create a floor layout that placed the departments with the highest revenue per square foot into locations with the most customer traffic.

# THE ROLE OF INTANGIBLE AND TANGIBLE CAPITAL IN DETERMINING FUTURE FIRM PERFORMANCE

---

Regular Session

---

***Ms . Irita Mishra***<sup>1</sup>

*1. Georgia Southern*

Today's economic environment calls for new rules for corporate investment. Traditional competitive mechanisms, like advanced technology, are not the only investments that can generate revenue with the amount of competition in the market. Companies can very easily imitate their competitor's practices. So, firms need to develop new sources for competitive advantage, through some form of capital investments, be it tangible or intangible. Policymakers and economists have analyzed the growing role played by intangible assets on firms' productivity over the last two decades. These assets can be in the form of intellectual property, copyrights, brand recognition, etc. If the value of a company's intangible assets stays positive and/or keeps increasing, it may lead to a rise in its stock price. However, high investment in intangible capital can also expose the company to additional risks. The firm might obtain lesser revenue from its investments in intangible capital than otherwise expected. This could occur if the investment decision is ill-informed, the market is underperforming, the firm misjudges its perceived control or the competitors develop stronger competitive advantages. The risk from investment in these intangible assets can impact future firm performance, which shows up as declining economic growth. This study looks into the impact of tangible and intangible intensity on future firm performance. The gap in the literature that this article addresses is in measuring the absolute and relative impacts of both tangible and intangible capital on future firm performance, leading to insightful theoretical and managerial implications along with directions for future research.

**Keywords:** *Intangible capital intensity, tangible capital, future firm performance, risk-free rate of return*

# Value of Accreditation for Computing Programs vs. Engineering Programs

---

Regular Session

---

***Ms . Caitlin McOsker***<sup>1</sup>

*1. Georgia Southern University*

This paper looks to investigate the value of ABET accreditation for students of computing programs as compared to engineering programs. This is done by comparing the number of job ads that indicate a preference or requirement for ABET accreditation for the two categories. Job ads are scraped from popular job posting website Monster.com using relevant search terms, then analyzed using a t-test to determine if there is a difference between the two groups.

**Student Papers  
(Undergraduate, Master  
and Ph.D Students) -  
Papers**

## **AN ANALYSIS OF BENIGN AND MALIGNANT TUMORS: A MACHINE-LEARNING MODEL**

### **ABSTRACT**

In this paper, we will be analyzing data collected by researchers in an effort to create a machine-learning model that will identify whether a tumor is cancerous or benign and does not require surgical intervention.

### **INTRODUCTION**

Among the worst three words you can hear in your life is, “you have cancer.” The lead up to these three words are expensive, time consuming, and emotionally draining and often a fight for life. In an effort to reduce costs, increase diagnosis time, and even predict diseases before they present symptoms, doctors are turning towards data-driven solutions to identify diseases sooner, quicker, and with lower expenses.

Today, doctors and analysts can use data analytics to identify genetics or symptoms that can predict a diagnosis or clue in a patient to a challenge they may face in their future. The increase in the use of data science in the medical industry lead us to the following question: *“Can we identify whether a tumor is cancerous without performing a biopsy on the patient by identifying trends and categories in similar tumors?”*

### **BENEFITS OF OUR APPROACH**

A data science solution to categorizing tumors as benign or malignant through the analysis of the features of the tumor would allow the patient to receive a quick diagnosis of the risks of their tumor and reduce the costs associated with the surgery that would otherwise have to be performed [1]. In the U.S. alone, over one million breast biopsies are performed each year [5]. Most often a needle biopsy is performed in order to identify if a patient has breast cancer. More often than not, a needle biopsy does not return a cancer diagnosis. Some patients will require surgery to identify whether the tumor is cancerous. This initial biopsy, or surgery, depending on what is best for the patient, does not include any of the treatment the patient will need given they do have cancer. The estimated national average for a breast biopsy performed in a hospital is \$5,325 [4]. That cost will have to be paid for by the hospital, the patient, or their insurance company.

Previously, we mentioned that over one million breast biopsies are conducted each year in the United States. If we could use a data science solution to predict that 1% of individuals who are recommended for a breast biopsy do not have a cancerous tumor with a high-level accuracy, we could save \$53 million dollars in a year.

With something as serious as a cancer diagnosis, we must be certain that our data proves the individual does not need a biopsy. This is why we determined an estimated potential cost saving at such a low percentage. Until we have enough training data that our models are incredibly accurate, there may not be many individuals that we can classify having a benign

tumor with a level of confidence close to certain. If our models do not return a level of confidence high enough, our patient will have to follow up with a biopsy. If our model identifies the patient likely has breast cancer, no money will be saved because a biopsy will need to be performed.

However, these models are beneficial in diagnosing breast cancer in a quick and efficient manner. It is important for the patient's health that treatment be started quickly after diagnosis. If we can conclude that a patient has breast cancer, we can streamline the process leading up the diagnosis in order to start treatment to target the disease as soon as possible.

### OUR DATA SET

The dataset we chose to help us answer our research question is titled, "Breast Cancer Wisconsin (Diagnostic) Data Set." The researchers who worked to collect the data used for our analysis are Dr. William H. Wolberg, Olvi L. Mangasarian, and the Computer Science Department at the University of Wisconsin.

Our dataset outlines 30 features of 569 breast tumors. Three hundred and fifty-seven, 62.7%, of the tumors listed in the data set are benign while two hundred and twelve, 37.2%, of the tumors are malignant. The researchers collected ten features from each tumor and then calculated the mean, standard error, and worst value for each feature resulting in 30 total features. The worst value for each dependent variable was calculated by finding the average of the worst three values for each feature. The ten core features listed in the data set are outlined in Table 1 below.

**Table 1: Feature Description [3]**

#	Core Feature	Description
1	Radius	Distance from center of the tumor to points on the perimeter
2	Texture	Standard deviation of the gray-scale values
3	Perimeter	Perimeter length of the core tumor
4	Area	Area of the core tumor
5	Smoothness	Local variation in radius length
6	Compactness	Squared (perimeter)/(area-1.00)
7	Concavity	Severity of concave portions of the contour of the tumor
8	Concave points	Number of concave portions location on the perimeter of the tumor
9	Symmetry	Similarity of feature to its opposite side
10	Fractal Dimension	"coastline approximation" -1

Each mean, worst, and standard error values for our features were calculated by a program analyzing a digitized image of a fine needle aspirate. A fine needle aspirate involves removing fluid and cells from breast lesion in a small needle. The procedure is very similar to that used for blood tests [2]. The mean, standard error, and worst value for each feature is a non-negative numeric value.

In addition to the 30 feature variables, each patient entry into our data set has a unique ID value. The ID number is unrelated to the patient but allows analysts to easily distinguish between patients. Finally, the dataset classifies each patient with a diagnosis. The diagnosis given to each patient is a character variable with the value 'M' for malignant or 'B' for benign.

### **DATA ANALYSIS**

In order to identify whether a tumor is cancerous or malignant, we need to use a classifier to label tumors as such. We used Weka, a machine learning software that contains algorithms used in data mining, to build a decision tree and clustering classifier (downloadable at: <https://sourceforge.net/projects/weka/>). After, we used the information learned from our classifiers to visually display our data using the business intelligence tool, Tableau. From our decision tree, clustering analysis, and visualizations created in Tableau, we can make predictions about whether a tumor is malignant or benign by analyzing its features.

### **RESULTS**

#### **A Weka Decision Tree Classifier**

We used the program Weka to create a decision tree that classifies a tumor as malignant or benign based on certain values of its features. The root, or first node, seen in our decision tree classifier pictured below, is the variable "area\_worst." Area worst is a measure of the size of the tumor. This feature is used as the root of the decision tree because it provides our classifier with the largest amount of information gain towards correctly identifying whether a tumor is malignant or benign.



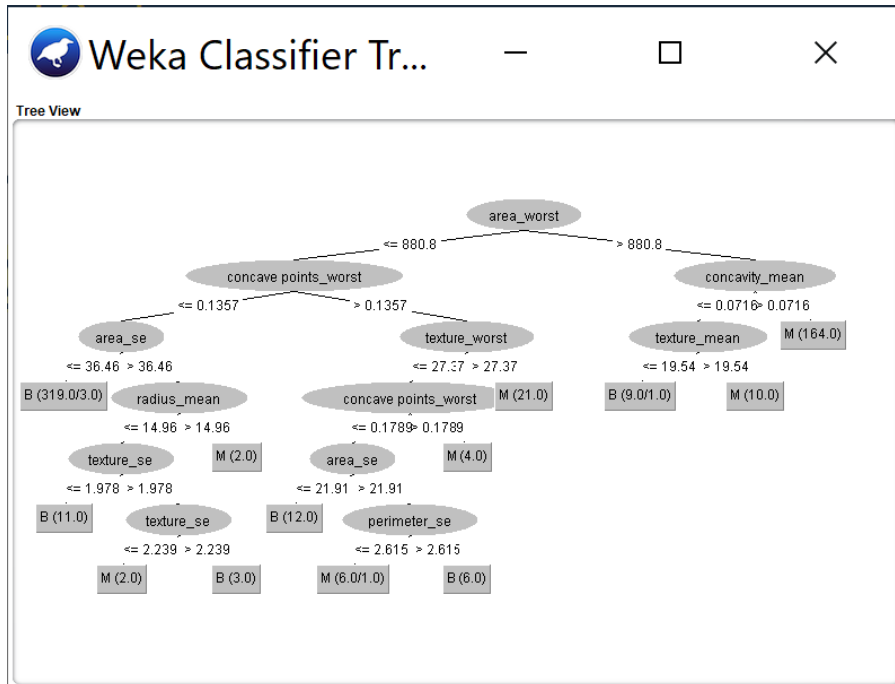

**Figure 1: Decision Tree Classifier for Breast Tumor Classification**

If a patient has an area worst value less than or equal to 880.8, the classifier will move to the child node of the root located to the left. If area worst is greater than 880.8, the classifier will move one node to the right. As we move down the decision tree, new questions are asked surrounding our data. These variables are selected based on the largest amount of information gain. If a patient has an area worst less than or equal to 880.8, the next feature analyzed will be concave points worst. The algorithm will continue running recursively down the tree until the patient's tumor has been classified as benign or malignant. The decision tree created by Weka has six levels of data. Once the branch of the tree terminates into a decision, malignant or benign, we know that no further information can be gained from the other features.

The decision tree classifier created by Weka correctly classified 530 of 569 data points in our dataset for a success rate of 93.1%. At the bottom of each branch of the tree is the classification. Whether the patient's tumor will be classified as malignant, 'M', or benign, 'B' is listed in the box at the bottom of each stem. Next to each classification is either a number or proportion. If a singular number is listed in the box, all testing data patients with tumors classified by that path of the decision tree had correctly classified tumors. If a proportion is listed in the box with the classification, it represents the proportion of test data classified correctly to test data classified incorrectly. The proportions listed of tumors correctly classified is an estimation of how accurate the model will be. However, we cannot be certain that paths that lead to 100% correctly classified test data will lead to 100% correctly classified live data.

In order to further explain how a patient's tumor is classified, let's look at the patient with the ID number of 842302. This patient has an area worst value of 2,019. This means we move

one step to the left of the decision tree. Patient 842302's concave points worst measure is equal to 0.2654, so we will move one step down and to the right. Next, we have a texture worst value of 17.33 which moves us left where we once again check the feature of concave points worst. Since our concave points worst score of 0.2654 is greater than 0.1789, we can classify patient 842302's tumor as malignant. If we look back at our data, we can see that the tumor is indeed malignant and our classifier was correct.

## A Weka Clustering Classification Model

We classified our data again, using a second technique, clustering, to see if we could build a more accurate model or present our data in a different manner. We had our model group our data into four clusters. The clusters were created based on similar features and classification. Three of the four clusters of data are classified as benign and one cluster is classified as malignant. 37% of the data or 211 patients with tumors are grouped in the second cluster with a classification of malignant. The three clusters with benign classification have similar feature values while the one case of malignant has extreme differences. For example, in "area worst" average of benign was 537 and malignant number was 1,426.

```
Final cluster centroids:
```

Attribute	Full Data (569.0)	Cluster# 0 (175.0)	1 (211.0)	2 (52.0)	3 (131.0)
id	30371831.4323	24951618.1143	36988315.1896	24199525.4423	29405565.5496
diagnosis	B	B	M	B	B
radius_mean	14.1273	13.0688	17.4899	11.5636	11.143
texture_mean	19.2896	16.1752	21.6213	17.8254	20.2758
perimeter_mean	91.969	84.0341	115.5567	75.7002	71.0347
area_mean	654.8891	531.7126	980.9701	417.8731	388.3061
smoothness_mean	0.0964	0.091	0.1029	0.1022	0.0906
compactness_mean	0.1043	0.0763	0.1456	0.1356	0.063
concavity_mean	0.0888	0.0422	0.1614	0.1091	0.026
concave points_mean	0.0489	0.0274	0.0882	0.0432	0.0167
symmetry_mean	0.1812	0.1695	0.1931	0.1896	0.1742
fractal_dimension_mean	0.0628	0.0601	0.0627	0.0731	0.0624
radius_se	0.4052	0.2553	0.6089	0.3386	0.3037
texture_se	1.2169	0.8677	1.2067	1.3733	1.6376
perimeter_se	2.8661	1.7854	4.3248	2.5951	2.0676
area_se	40.3371	20.6027	72.7841	23.7647	21.0162
smoothness_se	0.007	0.0057	0.0068	0.0096	0.0082
compactness_se	0.0255	0.0169	0.0324	0.0504	0.016
concavity_se	0.0319	0.02	0.042	0.0701	0.0164
concave points_se	0.0118	0.009	0.0151	0.0181	0.0079
symmetry_se	0.0205	0.0175	0.0205	0.024	0.0233
fractal_dimension_se	0.0038	0.0026	0.0041	0.0082	0.0032
radius_worst	16.2692	14.4057	21.1717	12.7574	12.2563
texture_worst	25.6772	21.2002	29.3463	23.0131	26.8058
perimeter_worst	107.2612	93.6665	141.637	85.3385	78.7556
area_worst	880.5831	643.7714	1426.4033	503.0173	467.6626
smoothness_worst	0.1324	0.1228	0.145	0.137	0.1229
compactness_worst	0.2543	0.1827	0.3762	0.3174	0.1283
concavity_worst	0.2722	0.1697	0.4525	0.3407	0.0915
concave points_worst	0.1146	0.0832	0.1828	0.1089	0.049
symmetry_worst	0.2901	0.2701	0.3241	0.2825	0.265
fractal_dimension_worst	0.0839	0.0761	0.0916	0.1008	0.0754

Figure 2: Clustering Classifier for Breast Tumor Classification

We can use the clusters we generated using Weka to classify new breast tumor data as malignant or benign by identifying which cluster centroid is closest to the new tumor's feature points.

### Using Tableau for Visualization

We can use Tableau to further visually show some of the claims we made based on our decision tree. First, we stated that area worst provided the most information gain in the decision tree model, followed by concavity mean and worst concave points. We can see the difference in the value assigned for area and concavity in benign and malignant tumors in Figure 3 below.

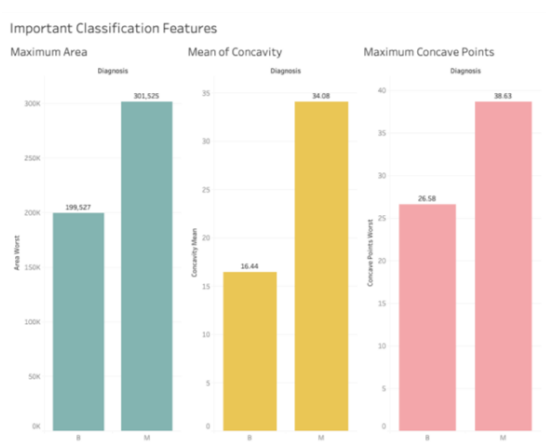

**Figure 3: Important Classification Feature Values**

We also established the features that were not used to classify the tumor in the decision tree did not provide the model with a significant amount of value add. You can see in Figure 4 that there is not a significant difference between the concavity standard error in malignant and benign tumors.

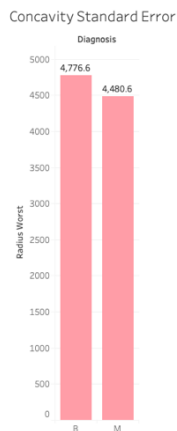

**Figure 4. Concavity Standard Error**

## LIMITATIONS AND FUTURE RESEARCH

As previously stated, our decision tree model correctly classified our test data 93.1% of the time. However, we cannot incorrectly tell someone their tumor is benign and they do not need further medical attention if that is not true. Due to the severity of the issue we are classifying, we cannot be as confident in our classification as if we were predicting the weather with 93.1% certainty.

In order to increase the accuracy of our models and classification, we would increase the amount of training data available. As with any machine learning and artificial intelligence algorithm, our models will become more accurate when they have more information they can learn from.

In addition, we will expand our research from breast cancer classification to the classification of different types of tumors to see if there were commonalities among the different locations of tumors.

We would like to look at building programs outside of Weka, perhaps through the use of Python. Through the programming of our own models, we could build different types of classifiers, including multiple layer perceptrons (MLPs), k-Nearest Neighbor (kNN), and regression models. In addition to the programming of these models, we could change their attributes (for example, the activation function in an MLP or value of k in kNN) in order to build a classifier possible with the highest correctly classified rate possible.

## REFERENCES

- [1] Bobriakov, I. (2018). Top 7 Data Science Use Cases in Healthcare. Medium, ActiveWizards: Machine Learning Company, available at: <http://medium.com/activewizards-machine-learning-company/top-7-data-science-use-cases-in-healthcare-cddfa82fd9e3>.
- [2] Borecky, N. (2018). Breast Fine Needle Aspiration (FNA). InsideRadiology, available at <http://www.insideradiology.com.au/breast-fna/>.
- [3] Breast Cancer Wisconsin (Diagnostic) Data Set (2016). Kaggle, UCI Machine Learning, available at: <http://www.kaggle.com/uciml/breast-cancer-wisconsin-data>.
- [4] Choosing Wisely (2014). Breast Biopsy, available at: <http://www.choosingwisely.org/patient-resources/breast-biopsy/>.
- [5] MDSave (2019). How Much Does a Breast Biopsy (Performed in Hospital) Cost Near Me?" available at: <https://www.mdsave.com/procedures/breast-biopsy-performed-in-hospital/d78af5cf>.

## APPLYING KAHOOT.COM IN OPERATIONS MANAGEMENT CLASS

**Huiling Liu**

Department of Logistics & Supply Chain Management  
Parker College of Business  
Georgia Southern University  
Box 8036, Statesboro, GA 30460-8036  
[hl02093@georgiasouthern.edu](mailto:hl02093@georgiasouthern.edu)  
(602) 919-7523

### ABSTRACT

Technology development has changed the learning environment dramatically. Not only have technology tools such as PowerPoint, Video, Folio, Email, etc. become popular in classroom, but also the new generation learners who grow up in a world embedded with technology like flexible and interactive learning environment. Under this circumstance, traditional teaching method such as visual and verbal explanation may not be effective anymore. New teaching methods are required. Is there a new teaching method that can effectively encourage learning and thus improve learning outcomes in new learning environment? This study aims to answer this question through an experiment study. We propose that the application of Kahoot.com in teaching can provide flexible and interactive learning environment to students and thus significantly improve students' learning outcomes. Kahoot.com is a game-based learning platform designed to assist instructors improve their teaching effectiveness and help students to achieve high level learning outcomes. Instructors can create various learning games, “kahoots”, which are comprised of questions, practices, and quizzes in different forms, for their courses. Students who obtain PIN from their instructors can play these games either by participating ‘individual to individual’ games or ‘team to team’ games during or after class. Based on theory of gamified learning, we believe that the application of Kahoot.com in teaching can positively influence students’ attitude of learning, willingness to devote to class, and learning outcomes. We plan to conduct an experiment study in the course of “Operations Management” in Georgia Southern University to estimate the proposed effects. Survey will be designed to estimate students' attitudes and willingness to devote to class.

## **HOW DO HEALTH BEHAVIORS AFFECT ACADEMIC PERFORMANCE?**

Abigail Wostbrock, College of Health and Behavioral Sciences, 800 S Main Street,

Harrisonburg, VA 22807, 201-739-1581, wostbram@dukes.jmu.edu

Anna Zheng, College of Health and Behavioral Sciences, 800 S Main Street, Harrisonburg, VA

22807, 540-209-1030, zhengax@dukes.jmu.edu

Sarah Douress, College of Health and Behavioral Sciences, 800 S Main Street, Harrisonburg,

VA 22807, 610-554-6505, douressc@dukes.jmu.edu

Noah McLemore, College of Health and Behavioral Sciences, 800 S Main Street, Harrisonburg,

VA 22807, 757-275-3040, mclemona@jmu.edu

Xiaohui You, College of Health and Behavioral Sciences, 800 S Main Street, Harrisonburg, VA

22807, 540-746-2956, youxx@jmu.edu (Instructor)

### **ABSTRACT**

Student health behaviors reflect a broad pattern that affects students' study life and academic performance. It creates an environment, either healthy or unhealthy, that in turn affects other students as well. With firsthand survey data from James Madison University students, this study examines the effects of health behaviors and socio-demographics on students' academic performance, as measured by their grade point average (GPA). We found that white young adults had relatively better performance averages when compared to other ethnic groups. This pattern was the same for both males and females. Student smokers were found to have lower GPA than nonsmokers, student athletes to have lower GPA than nonathletes, and drinkers to have lower GPA than nondrinkers, while not significantly. As expected, we found that students enrolled in more credit hours are associated with a higher GPA and statistically significant. This may be because students who perform better academically tend to register for more credit hours. This study helps students better understand the factors that affect their academic performance. It provides students with insight that findings may or may not be consistent with an original hypothesis.

## **INTRODUCTION**

Health behaviors, socio-demographic factors, and other factors could influence students' grade point averages (GPA) significantly. However, the impact of outside factors centered around students' health behaviors and socio-demographic factors has been in question for years. It is important to understand the significance of these factors in relation to a student's average academic achievement scoring. The student health behavior reflects a broader pattern that could affect students' study life and academic performance. Health behaviors also create an environment, either healthy or unhealthy, which in turn may affect other students. The research in this project was conducted to determine the extent to which health behaviors and socio-demographic factors, including smoking, drinking, gender, grade, and other factors, influence JMU students' GPA.

A college students' GPA represents the average value of accumulated final grades earned in courses taken. It is used to summarize a students' academic achievement during their time in school. GPAs are influenced by a number of outside factors concerning a students' health behaviors and socio-demographic factors. There are a large amount of factors that contribute to the increase or decrease of one's average academic achievement measure. To determine the impact of these factors, such as smoking, drinking, gender, grade, and other factors on a student's GPA, data was collected among James Madison University (JMU) students.

Employing an anonymous online survey from the JMU population, this study is intended to explore the association of health behaviors and socio-demographic factors on student's grade point averages at JMU. Statistical analysis tests were run to determine which factors of a student's life had a significant effect on their GPA.

## **LITERATURE REVIEW**

### **The Effect of Academic Load on Academic Achievement**

Academic load and course difficulty are both statistically significant in predicting academic achievement. The rising tuition rates force students to balance school life and their financial needs which increased the number of part-time students [5]. Part-time students are students that are enrolled in less than 12 credits and are found to be less committed to their education than full-time students [2]. Students who register for more credit-hours tend to earn higher GPAs while students who register for fewer credit-hours earn lower GPAs [11]. Possible explanations are that heavier course loads force students to manage their time more effectively [11]. Time management is found to be a significant predictor on academic performance [5].

### **Cigarette Usage**

For smoking behaviors, smoking and lower academic achievement mutually predicted each other [4]. Male and female students who reported higher academic achievement (GPAs) are less likely to be waterpipe tobacco smokers or cigarette smokers [12]. The frequency of smoking also predicts academic achievement. Regular, or daily smokers, were found to have lower academic performance than infrequent smokers [6]. In addition, the co-occurring association of marijuana and cigarette use was very strong, as a lot of smokers tend to use marijuana along with smoking

cigarettes. Marijuana usage during college is a barrier to academic achievement, with direct and indirect adverse effects on academic outcomes [1]. Students who use marijuana not only demonstrate poorer cognitive inhibition, a direct adverse effect, but also skip more classes than students who do not smoke marijuana, an indirect adverse effect [1].

### **Alcohol Consumption**

Students who consume moderate to heavy amounts of alcohol have a lower academic performance (GPAs) than those who consumed none to low amounts alcohol [6]. Early drinking behaviors predict lower academic achievement [4]. Studies found that heavy drinkers are more likely than non-heavy drinkers to report that alcohol consumption caused them to miss class and perform poorly on tests or projects [2]. Students who consumes alcohol frequently have a lower value on achieving good grades [2].

### **Grade Level**

There is a positive correlation between more cumulative credit hours (senior students) and academic achievement [8]. Students typically have a lower academic performance during their first year in college, because they are moving into a new environment [7]. As students mature academically, so does their GPA [8]. A possible explanation could be because students become more accustomed to the learning environment and therefore are more committed to the educational process [7].

### **Race and Ethnicity**

The average African-American students score lower than 75% of White students on standardized tests [10]. Studies found that African-American students have significantly lower grade point averages than White students [10]. This racial gap could be due to the difference in high school academic performance. For example, African-American and Latino students took lower level math classes, compared with White students [10]. Since White students took higher-level courses, they are better prepared for the rigorous curriculum at the college level.

### **Student-Athlete**

Student-athletes have to balance the responsibilities of being both a student and an athlete. During in-season, student-athletes had a lower GPA than during out-of-season [9]. Male student-athletes report lower grades than non-athletes [14]. Possible explanation could be due to lack of motivation, which is often reflected in reduced academic achievement [3]. While extracurricular activities are important for academic growth, activities like employment and collegiate athletics had a negative effect on academic performance [15]. In general, the more the student commits to the athletic role, and the less they commit to the academic role, the lower the GPA.

The purpose of this analysis was to determine which factors of a student's life had a significant effect on their GPA. Specifically, we tested whether or not being a smoker could affect the student's GPA or not. Using data collected from JMU students, the effect of smoking, grade level, the number of credit hours students were enrolled in (part time or full time) on student's GPA were



tested. The results from these tests will be a representation of how influential these factors are on JMU students' grade point averages.

## METHOD

### Participants & Data Collection

The participants in this study consisted of 325 students from James Madison University (JMU) in Harrisonburg, Virginia. The sample included 199 females and 129 males aged 18 to 23. Participants were recruited from different buildings on campus at various times of the day. Each student was given an anonymous Qualtrics survey link containing questions detailing various variables of interest. The data from the surveys was then transferred to an SPSS data set. Participation in this study was voluntary. Random sampling was used as each student surveyed was just as likely to get surveyed as any other student at JMU.

### Data & Measures

On the Qualtrics survey, students were asked to indicate their estimated average GPA, grade level, gender, race, if they have a job (and if it's on campus), the amount of times food is purchased on campus per week, the amount of money spent on food on campus per semester, their budget per semester (not including tuition), if they drink or smoke, how many credit hours they registered for the current semester, and if they were an athlete or not.

**Table 1: Descriptive Statistics**

	N	Min	Max	Mean	Std. Dev	Skewness	SE	Kurtosis	SE
GPA	325	2	4	3.1486	0.40758	-0.181	0.135	-0.226	0.27
race	325	1	3	1.32	0.665	1.814	0.135	1.719	0.27
drink	325	0	1	0.85	0.358	-1.961	0.135	1.857	0.27
smoke	325	0	1	0.28	0.448	1.002	0.135	-1.003	0.27
athlete	325	0	1	0.21	0.41	1.414	0.135	-0.002	0.27
credit	325	6	22	14.89	1.833	-0.589	0.135	3.638	0.27

GPA was coded by having students record their cumulative GPA as of the beginning of November 2019. Grade was coded by having students record what year they were (i.e. freshman, sophomore, junior, or senior) during the 2019 Fall Semester. Gender was presented as male or female. Race was coded by white, black, or other. Participants recorded yes or no to answer if they had a job and if it was on campus. The amount of times food was purchased on campus per week was coded as a whole number. The amount of money spent on food on campus per semester and participants' budgets per semester were coded as monetary values. The smoking variable was coded by giving the option to choose between smoker or nonsmoker. Similarly, the drinking variable was presented as drinker or non-drinker. For credit, the students recorded how many credit hours they were enrolled in for the Fall 2019 semester. The athlete variable was presented as athlete or non-athlete (See Table 1: Descriptive Statistics)

To analyze the data, several normality and hypothesis tests were used to determine the significance of the variables. When performing normality tests for GPA, it was concluded that GPA was

normally distributed using a histogram, a normal Q-Q plot, and the Kolmogorov-Smirnov Test. Since the data was normally distributed, several parametric tests were able to be performed. A one-sample t test was used to determine if the mean GPA in the sample was equal to the mean GPA in the population (3.19) and a two-independent sample t test was also performed. In addition, a One-Way ANOVA using race, a Two-Way ANOVA, a simple main effect test, and a Post-Hoc test were performed. Lastly, correlation was computed using the Pearson correlation coefficient, and regression was calculated using a multiple linear regression, adjusted  $R^2$ , and coefficients interpretation.

## EMPIRICAL RESULTS

Using one-sample t test, we determined that the mean GPA in the sample was equal to the mean GPA in the population, 3.19. Hence, our data could be a good representative for the JMU population. According to the Table 2 results (Two independent sample t tests), at a significance level of 0.05, we found that athletes and smokers have statically significantly lower GPAs compared with non-athletes and non-smokers. Meanwhile, drinking does not produce a significant difference on GPA. However, there is evidence that non-drinking students have a significantly higher GPA at a .1 level of significance.

**Table 2: Two Independent Samples Test**

Variable		Levene's Test		t-test	
		F	P-value	t	P-value
GPA	smoke	1.68	0.196	-4.364	0
GPA	drink	1.95	0.164	-1.704	0.089
GPA	athlete	2.181	0.141	-2.929	0.004

**Table 3: One-way ANOVA using race**

Dependent Variable: GPA

F	Sig.
8.863	0.000

**Post Hoc Test using Tukey HSD**

	(I) race	(J) race	Mean Difference (I-J)	P-value
Comparison 1	White	black	.28523*	0.000
Comparison 2	White	other race	0.14852	0.092
Comparison 3	Black	other race	-0.13671	0.329

\*. The mean difference is significant at the 0.05 level.

From the One-way (Table 3) and Two-way ANOVA tests (Table 4), we found that GPAs are significantly different for smoker vs. nonsmoker and athlete vs. nonathlete. Again, we find there is no significant differences on GPA between drinker and nondrinker. Using a Post Hoc test, results show that white students have higher GPAs than black students, statistically significant. There are,

however, no significant differences between white and other races and between black and other races.

**Table 4: Two-way ANOVA**

Dependent Variable: GPA		
Source	F	P-value
Intercept	7236.826	0.000
Smoke	7.932	0.005
Race	6.026	0.003
smoke * race	0.135	0.874
Intercept	6331.530	0.000
Race	7.270	0.001
Athlete	5.286	0.022
race * athlete	0.154	0.857
Intercept	5276.625	0.000
Drink	0.318	0.573
Race	8.855	0.000
drink * race	1.255	0.287

**Table 5: Pearson Correlation**

	GPA	Race	drink	smoke	athelte	credit
GPA	1	-.175**	-0.094	-.236**	-.161**	.149**
Race		1	-.119*	0.092	0.042	0.06
Drink			1	0.107	0.051	-0.096
Smoke				1	0.065	-0.041
Athlete					1	-0.08
Credit						1

\*\* . Correlation is significant at the 0.01 level (2-tailed).

\* . Correlation is significant at the 0.05 level (2-tailed).

According to the Pearson Correlation in Table 5,  $r = -.175$  for GPA and race, which shows there is a weak, negative correlation that is statistically significant at the 0.01 level.  $R = -0.094$  for drink and GPA, showing a weak and negative correlation that is statistically significant.  $R = -.236$  for GPA and smoke, which shows there is a weak, negative correlation that is statistically significant at the 0.01 level.  $R = -.161$  for athlete and GPA, showing that there is a weak, negative correlation that is statistically significant at the 0.01 level.  $R = .149$  for credit and GPA, which shows that there is a weak, negative correlation that is statistically significant at the 0.01 level.

Finally, we estimated OLS for all interested variables in this study. According to our regression result (Table 6), all other variables held constant on average, at a 0.05 level of significance, a student smoker was associated with .181 point statistically significantly lower GPA and an athlete was associated with a .126 significantly lower GPA. Surprisingly, there is no significant difference

between drinkers and nondrinkers. While being a drinker was associated with a 0.084 lower GPA, this was not found to be significant.

**Table 6: OLS estimation**

	<b>Coefficients</b>	<b>t</b>	<b>P-value</b>
C	2.989	15.489	0.000
race	-0.103	-3.154	0.002
drink	-0.084	-1.382	0.168
smoke	-0.181	-3.74	0.000
athlete	-0.126	-2.394	0.017
credit	0.03	2.535	0.012
<b><u>R Square</u></b>	<b><u>Adjusted R Square</u></b>	<b><u>Durbin-Watson</u></b>	<b><u>F</u></b>
0.124	0.11	2.167	8.996

As expected, we find that students enrolled with more credit hours have a higher GPA. One more credit hour is associated with 0.03 increase on GPA, statistically significant. First, students who perform better academically tend to register for more credit hours. In fact, only those with good academic performance could be allowed to register for more. On the other hand, courses are closely related, as their contents always compensate and influence each other.

The demographics of the enrolled student population at James Madison University is 75.1% White, only 4.59% Black or African American, and the remaining is composed of other various races. The White group is the majority, and our research suggests the White race was associated with a statistically significant higher GPA than other groups, especially compared with the African American group.

## CONCLUSION

Health behaviors, socio-demographic factors, and other factors could influence students' grade point averages (GPA) significantly. The goal of this study was to examine the extent of impact that student health behaviors and socio-demographic factors have on students' GPA. Stress is inevitable in college and is found to influence substance abuse, such as smoking and drinking. Those who consume alcohol or smoke have lower reported academic performances than those who do not consume alcohol or smoke. Socio-demographic factors, such as grade level and race, also affects students' GPAs. White students tend to earn a higher GPA than African-American students and there is a positive correlation between grade level and academic achievement. Other factors, such as course load, living arrangements, and being a student-athlete, also predict academic achievement. Students that take a heavier course load with more credit hours and non-revenue athletes are found to have higher GPAs.

Using data collected from JMU students, we find that smoking can significantly impact students' academic performance. There is evidence of the negative effect drinking can have on a student's academic performance, though this was not statistically significant. The test results represent how influential those health behaviors and socio-demographic factors are on JMU students' grade point

averages. Based on this analysis, we attempt to determine which factors of a student's life have significant effects on their GPA in hopes to help their academic performance in the future.

One advantage of the study is that it gives a better understanding of factors that affect the GPA of JMU students. It also allows future research to be conducted based on our study and its findings. Along with these advantages, the disadvantage is that the findings may not give a fully accurate representation of the entire JMU student body due to the relatively small sample size (only 325 observations). If this study were to be conducted again in the future, a recommendation would be to use a larger sample size to overcome this disadvantage.

One issue is that participants could have been exaggerating their results or even changing answers due to this being an academic study. If a participant did not feel comfortable answering honestly, they may have changed their answers. Another issue was the sample size (only 325 observations) could have been larger. If there were more participants, the data could have better represented the student body at JMU. In the future, the survey could be given online to get a larger quantity and possibly quicker results.

Future studies should continue to examine and evaluate the relationship and impact of outside factors on a students' grade point average. Additional research should increase sample sizes, utilize different questionnaire distribution strategies, and include other outside factors that may exhibit even greater statistical significance on GPA.

## REFERENCES

- [1] Arria, A. M., Caldeira, K. M., Bugbee, B. A., Vincent, K. B., & O'Grady, K. E. (2015). The academic consequences of marijuana use during college. *Psychology of Addictive Behaviors*, 29(3), 564.
- [2] Duby, P., & Schartman, L. (1997). Credit Hour Loads at College Onset and Subsequent Academic Performance: A Multi-Institutional Pilot Project. AIR 1997 Annual Forum Paper. El
- Ansari, W., Stock, C., & Mills, C. (2013). Is alcohol consumption associated with poor academic achievement in university students?. *International journal of preventive medicine*, 4(10), 1175.
- [3] Gaston-Gayles, J. L. (2004). Examining academic and athletic motivation among student athletes at a Division I university. *Journal of College Student Development*, 45(1), 75-83.
- [4] Latvala, A., Rose, R. J., Pulkkinen, L., Dick, D. M., Korhonen, T., & Kaprio, J. (2014). Drinking, smoking, and educational achievement: cross-lagged associations from adolescence to adulthood. *Drug and alcohol dependence*, 137, 106-113.
- [5] MacCann, C., Fogarty, G. J., & Roberts, R. D. (2012). Strategies for success in education: Time management is more important for part-time than full-time community college students. *Learning and Individual Differences*, 22(5), 618-623.
- [6] Meda, S.A., Gueorguieva, R.V., Pittman, B., Rosen, R.R., Aslanzadeh, F., Tennen, H, et al. (2017) Longitudinal influence of alcohol and marijuana use on academic performance in college students. *PLoS ONE*, 12(3): e0172213. doi:10.1371/journal.pone.0172213
- [7] Melaku, L., Mossie, A., & Negash, A. (2015). Stress among medical students and its association with substance use and academic performance. *Journal of Biomedical Education*, 2015.
- [8] Nelson, D., Misra, K., Sype, G. E., & Mackie, W. (2016). An Analysis of the Relationship between Distance from Campus and GPA of Commuter Students. *Journal of International Education Research*, 12(1), 37-46.
- [9] Scott, B., Paskus, T., Miranda, M., Petr, T., & McArdle, M. (2008). In-season vs. out-of-season academic performance of college student-athletes. *Journal of Intercollegiate Sports*, 1, 202-226.
- [10] Steele-Johnson, D., & Leas, K. (2013). Importance of race, gender, and personality in predicting academic performance. *Journal of Applied Social Psychology*, 43(8), 1736-1744.
- [11] Szafran, R. F. (2001). The effect of academic load on success for new college students: Is lighter better?. *Research in Higher Education*, 42(1), 27-50.
- [12] Tucktuck, M., Ghandour, R. & Abu-Rmeileh, N.M.E. (2018) Waterpipe and cigarette tobacco smoking among Palestinian university students: a cross-sectional study. *BMC Public Health* 18(1), 1. doi:10.1186/s12889-017-4524-0
- [13] Turley, R. L. (2006). When parents want children to stay home for college. *Research in Higher Education*, 47(7), 823–846.
- [14] Umbach, P.D., Palmer, M.M., Kuh, G.D., & Hannah, S.J. (2006). Intercollegiate athletes and effective educational practices: Winning combination or losing effort?. *Research in Higher Education*, 47, 709-733.
- [15] Ung, K. (2019). Variables that Predict the Academic Success of First Generation College Students at Faith-Based Institutions (Doctoral dissertation, Union University).

INTEGRATING BLOCKCHAIN TECHNOLOGY WITHIN THE LOWE'S COMPANY INC.  
TO ENHANCE TRACEABILITY AND VERIFY WOOD CERTIFICATION ALONG THE  
SUPPLY CHAIN

Taylor Miller, M.S. Environmental Studies and Sustainability, College of Charleston, 66 George St, Charleston, SC 29424, (843) 805-5507, [millertp1@g.cofc.edu](mailto:millertp1@g.cofc.edu)

**ABSTRACT**

Corporate sustainability is becoming more attractive and necessary as companies strive to improve their long-term economic development by merging responsibility and profit. One technique sustainability-oriented companies have been employing is enhancing traceability within their supply chains. Scholars and supply chain managers believe that blockchain technology can benefit and help in enhancing green supply chain management. This work is focused on developing a wood traceability method that integrates blockchain technology within the Lowe's Company in order to enhance traceability and verify certification of wood along the supply chain. This project will investigate can wood be accurately tracked throughout the supply chain to ensure certification integrity.

**INTRODUCTION**

**Corporate sustainability**

Engert et al. reflect on the perceived notion that environmental and social responsibility deters from profitable business strategies, but this antiquated paradigm is being shifted with conscious-consumer demands and advancing technology [6]. Companies and scholars identify the benefits of sustainability practices to improve customer satisfaction, compliance, and stakeholder happiness. Blockchain technology is gaining attention in logistics and supply chain management and has the potential for elevating transparency. Supply chain transparency is one of the demands made by environmentally conscious consumers.

Corporate sustainability does not have a formal definition, but scholars have agreed with the practices of corporate sustainability carrying out the triple bottom line (TBL) accounting framework, which is composed of evaluating financial return, social impact and environmental responsibility [2]. The book *Corporate Sustainability: the New Pillar of the Circular Economy* investigates the integration of sustainability in the corporate world. The authors propose that sustainability on the corporate level is guided by the idea of industrial symbiosis, which is done by shifting the focus to prioritizing profit while incorporating social responsibility. Sustainability is defined in this book, as development that meets the needs of the present without compromising the ability of future generations to meet their own needs [2]. The authors advocate that the adoption of the TBL gives companies a broader perspective of their performance and creates greater business value.

The integration of corporate sustainability into a company's business strategy is one key component to enhancing the benefits and operations of green initiatives. To effectively incorporate sustainability practices, scholars argue that corporate sustainability needs to encompass a holistic perspective, meaning that all three dimensions (TBL) of corporate sustainability must be considered, as well as their impacts and interrelations [6]. Companies usually initiate corporate sustainability initiatives on an operational level and rarely implement them in strategic management on all business levels [6]. Strategic management is derived from military science and is used to give companies an advantage by creating a unique place in the market by doing things that serve consumers' needs and preferences better than competitors or reduces the cost for the company. Corporate sustainability has been recognized as successful once economic development, environmental protection, and social responsibility intersect. Corporate sustainability management is acknowledged as a strategic profit-driven response to environmental and social concerns while achieving sustainability initiatives. The reconstructed business strategy was presented by Engert et al. "to reflect the fact that what is good for society does not necessarily have to be bad for the firm, and what is good for the firm does not necessarily have to come at a cost to society" [6].

Companies often initiate sustainability on an operational level, but there is a need to integrate sustainability on all business levels. Integrating sustainable practices within a supply chain, for example, can broaden performance and create greater business value. Sustainability integration within supply chain management is essential for benefits at both global and local levels because supply chain activities significantly influence green initiatives and social responsibility [13]. Scholars and supply chain managers are becoming more attracted to blockchain technology for its potential to enhance green supply chain management [13] [10]. In this study, a technical and economically feasible wood tracking system will be developed to heighten Lowe's Company Inc. due diligence by integrating blockchain technology as a tool to enhance traceability of certified wood products along the supply chain.

## **SUSTAINABLE SUPPLY CHAIN MECHANISMS**

### **Sustainable supply chain governance**

Companies can integrate sustainability into their business strategy in various ways, for strategies aimed to improve sustainability performance; companies establish governance mechanisms to manage interactions within their supply chain [9]. Sustainable supply chain management (SSCM) research is recognizing there is a need for deepening the knowledge of governance mechanisms [9]. Monks and Minow define governance as the structure that ensures decisions are made to develop long-term, sustainable value for an organization [15]. Sustainable supply chain governance mechanisms are defined by Formentini et al. as practices, initiatives, and processes used by the focal firm to manage relationships between internal functions and departments, their supply chain members and stakeholders to successfully implement their corporate sustainability approach [9].

Two relevant factors drive governance mechanisms: collaboration and formalization. Collaboration is practiced when a company uses its market power to implement sustainability strategies or adopt a shared collaborative governance style [9]. Non-collaborative is used most in SSCM, which is when the firm utilizes contracts and agreements to outline governance parameters and enforce regulations with supply chain partners [9]. The second factor that drives governance mechanisms is formalization, which is defined by Formentini et al. as the extent to which decision-



making is regulated by explicit rules and procedures [9]. Formal mechanisms are carried out within an organizational structure, which defines interactions through command structures, incentive systems, standard operating procedures and documented dispute resolution procedures [9]. When companies have a dynamic supply chain, they often adopt formal mechanisms to establish structure and alleviate issues with a complex supply chain and potentially unstable circumstances [9].

With increasing consumer demands and stricter government regulations, Green Supply Chain Management (GSCM) has captured the attention of many organizations interested in improving their sustainability-related operations [4]. Implementing GSCM can be done in various ways such as environmental management systems, lean production, ecodesign, use of environmentally friendly materials, and commitment to green practices during purchasing and manufacturing activities, etc. Multiple-criteria decision-making (MCDM) has been suggested for solving project decision-making problems and issues for the evaluation and selection of green suppliers.

The decisions made within a strategic purchasing participation model are linked through various dependencies; purchasing performance is linked to supplier performance, while supplier performance is dependent on suppliers that can support purchasing goals. With these interconnected dependencies, suppliers are viewed as external stakeholders, which is that they are linked to buyer goals, actions, and fortunes [16]. The principle of unity of command is a classic organizational theory stating that there should be one plan for a group of activities having the same objective, keeping a check on incompatible expectations and partners. Participation in strategic decision-making and planning is one of the mechanisms of the unity of command.

Strategic purchasing participation provides clarity for suppliers about expectations as well as identifies the expected purchasing capabilities within an organization. Nair et al. states that firms operating in the same industry with similar operation strategies can have dramatically different levels of performance due to differences in functional level capabilities [16]. Looking at the mechanisms of purchasing, integrating strategic planning provides clarity on supplier criteria and enables the selection of capable suppliers for strengthening organizational strategic capabilities. Supplier selection criteria allow set qualifying, strategic and operational standards for buyers to incorporate external resources and internal stakeholders' goals. Participating in strategic planning, allows supplier selection to be precise with organizational aims. Suppliers are evaluated by their strategic and operational performance. Strategic performance is defined as providing product technology and assisting in product development efforts. Operational performance is carried out in cost, quality, delivery, and flexibility.

A study conducted by Formentini et al. provides empirical evidence and develops a theory for practitioners seeking to implement sustainability initiatives at the supply chain level [9]. SSCM initiatives and how they are implemented are results of environmental and market pressures. There are two common strategies for SSCM implementation. One is "supplier management for risk and performance" which is sparked by the company's fear of reputation damage due to sustainability-related problems, proposing additional criteria for supply chain partners. The second trigger is "supply chain management for sustainable products". This strategy carries out the concerns for product-related issues, addressing the life-cycle standards at the supply chain level. The research established the following character-based sustainability profiles: sustainability leaders, sustainability practitioners, and traditionalists; traits to determine characterization was based on the companies' level of collaboration and formalization. *Sustainability leaders* are characterized by a TBL approach to business with a strong focus on supply chain-oriented initiatives.

*Sustainability practitioners* are characterized by a myopic approach to business sustainability with a limited focus on one or two TBL dimensions and isolated SSCM initiatives. *Traditionalists* are characterized by the use of traditional approaches to business that don't necessarily include explicit TBL and SSCM initiatives but might present sustainability elements.

Governance mechanisms and initiatives help in setting the foundation for further aspects of corporate sustainability such as traceability which will be discussed in the following section.

### **Traceability**

One technique sustainability-oriented companies have been employing is enhancing traceability. Dai et al. identify the importance of supply chain traceability for managing product safety, product recall, reverse logistics, etc [3]. A supply chain traceability system manages supply chain partners and product information so that each unit/batch/component is traceable and trackable. Adopting traceability systems can be difficult to implement into supply chains. One major issue is getting all supply chain partners to identify the costs and benefits of adopting a traceability system. Another big issue is the technical work that must be executed to exchange the data successfully. Without technical integration, the work becomes highly dependent on adding manpower to capture and submit the data, which can be very expensive. Another key concern is the integrity of the information shared within the supply chain because the integrity of the information is dependent on supply chain partners' decisions to release and/or withdraw traceability information [3]. Traceability systems are complex and involve various design decisions; companies must select the proper technologies for their supply chain and desired traceability levels.

Multiple technologies can be employed to achieve efficient tracking and tracing of a product throughout the supply chain: identification technology (e.g. barcode vs. RFID), ID coding (e.g. batch vs. item-level), tagging level (e.g. pallet vs. case-level) and logistics hierarchy (e.g. finished product vs. component-level). Another concern is that the design, implementation, and maintenance of a traceability system is often decentralized; the motivations of each party are often different creating various depths of commitment. The incentives for each partner may vary, so every partner must be motivated to a level that maintains or enhances the efficiency of the entire supply chain [3].

A real-world example can illustrate the difficulties of employing a traceability system. In 2003 Wal-Mart authorized 100 of its top consumer goods suppliers to implement pallet and case-level RFID tagging. Many of the suppliers refused because they had to pay for the tags and the benefits of this new tagging system were not identified to them [20]. Wal-Mart restructured how they implement their traceability system by focusing on collaboration and cost-sharing. Identifying the benefits to their supply chain partners of implementing the RFID across the supply chain helped reinforce suppliers' decision to implement the RFID tracking system [20]. Clarifying the benefits to supply chain partners will improve the adoption of new tracking methods companies wish to establish in their supply chain.

## **BLOCKCHAIN TECHNOLOGY**

Technology advancements have created new avenues to integrate sustainability practices into the corporate world. Sustainability integration within supply chain management is essential for

benefits at both global and local levels because supply chain activities significantly influence green initiatives and social responsibility. Scholars and supply chain managers believe that blockchain technology can benefit and help in enhancing green supply chain management [13] [10]. The arrival of this technology is timely because consumers are demanding supply chain transparency. The validity of materials and sourcing concerns is problematic when supply chains are multi-tiered and increasingly global in scope. Currently, blockchain applications are being used and developed within the finance sector, but scholars and supply chain managers have taken notice and are quickly applying the technology to customer services while also achieving competitive advantages [25].

Blockchain technology is also referred to as distributed ledger technology and is defined by Kouhizadeh et al. as “decentralized databases or ledgers of records that are shared among networks and supply chain participants. In blockchains, records and data are secure, traceable, and auditable, and maintained on a peer-to-peer network” [13]. Blockchain technology is unique from other tracking technologies because every transaction is linked to the previous data entry creating a chain of blocks [13] [10].

There are two types of blockchains, public and private. Public blockchains are available for anyone to record transactions and track their historical transactions in the ledgers; no authorization is needed to contribute to the blockchain. The popular bitcoin cryptocurrency which made blockchain popular was developed on public blockchains, which require high levels of security. Private blockchains are comprised of users who know each other and participate in a permission blockchain where only approved participants can access the ledgers. In private blockchains, there is a validator who oversees the participants by granting permission to ledgers and maintaining the privacy of the network [13][10]. I will focus on the elements and benefits of a private blockchain for my study.

### **Blockchain benefits**

Looking at transparency and security, Kouhizadeh et al. believe that these elements of blockchain technology make it attractive for supply chain integration. Information is constructed into blocks within blockchain technology; each data entry or block has its timestamp and hash value that is related to previous blocks within the chain [13]. In private blockchains, the validator must be trusted, because they give authorization to users to record and trace information. With blockchains' decentralized structure, single point failure is eliminated, which can be an issue in centralized databases.

Decentralization of consensus validation limits data misuse and network manipulation, in addition to safeguarding the network from hacking or crashing. The authors present the term immutability and state it means that records cannot be changed or modified without network member consensus. Blockchain data and ledgers are immutable, which builds trust amongst participants that the history of records is reliable and unaltered. A private blockchain would utilize smart contracts, which are computer codes and scripts that outline terms and rules to be followed for data entry, modification or deletion. Smart contracts automatically approve the terms of agreements by checking the predetermined conditions established and validated by the blockchain contributors, thus prompting the related action after conditions are met. An example of a smart contract is an automatic payment that is performed, the criteria being a particular date when the payment is due or changes in payment due to value change, i.e. credit card automatic payments.

Blockchain technology could be used in many ways to improve sustainable supply chain initiatives [13] [10]. Experts predict that blockchains efficiency gains could range anywhere from an estimate of \$20 billion per year for payments, trading, and compliance to more than \$176 billion per year in business value-add across industries [14]. Sustainable supply chains must select suppliers and evaluate performance to ensure sustainable practices are being conducted, which was earlier discussed by Nair et al. [16]. The concerns with supply chain activities are that information can be hidden from buying partners, which can prove risky and compromise supply chain strength. Supplier selection and evaluation are dependent on the information which is not always accessible, certifiable and audited; a higher opacity of information is observed with social and environmental reporting. This missing or obscured information could become transparent with the use of blockchain technology. Supplier partners' historical performance and sustainability data can be made available on the blockchain, allowing companies to improve supplier selection by evaluating sustainability within operations. The integration of blockchain technology also provides information for the whole supply chain across multiple stages and sub-suppliers.

Environmental supplier development and training programs are being instituted by companies such as Dell, IBM, Lucent, and PepsiCo. Recording and monitoring suppliers allow for these companies to illustrate their supply chain capabilities and share the documentation with a wide array of customers. This information can show more than just the connections of suppliers to these organizations (Dell, IBM, and Lucent); it can also provide insights into the suppliers involved in industry associations and coalitions such as the Electronic Industry Citizenship Coalition (EICC). Scholars admit that blockchain and its integration for sustainable supply chains are undeveloped and require investigation. Many frameworks have been studied but there is a need to grow the conceptual models into empirical studies [13] [10] [25].

### **Blockchain limitations and concerns**

Companies' initiatives to become sustainable need to appreciably merge profit and responsibility. Agrawal et al. presented the universal limitations of blockchain integration [1]:

**Cost:** The cost of blockchain technology can restrict blockchain adoption because of the cost of maintaining the system. Decentralized signature verification can be computationally complex especially in supply chains with thousands of products and related information. In some supply chains, the millions and millions of transaction verifications needed will use a considerable amount of computer power and energy. Another concern is the maturity of blockchain technology. Developers and scholars are still experimenting to solve challenges and limits for applying blockchain outside of the finance sector [1] [7]. With ongoing strides and evolution in IT, these two concerns are believed to be short-lived given the rapid nature of development in IT [7].

**Technology Integration:** Blockchain adaptation and integration into existing systems i.e. Internet of Things (IoT) can be a major challenge. Integration might require significant changes or complete technology replacement that can be a costly and time-consuming process. Therefore, high motivation and willingness among the involved actors are required to implement the technology. Moreover, blockchain adaptation will also be a cultural change from centralized to a decentralized network that might require additional investment in human resources [1].

**Security at the Product Level:** Security must be incorporated at both the business/information and product levels, to protect both from attacks and maintain information integrity. The business level is where traceable information is recorded and shared among the businesses or the supply

chain partners, ensuring that information is secure and reliable at the business-to-business level. The product level encodes product information and its traceability marker (RFIDs, barcodes, etc), the traceability marker must be secure to inhibit forms of counterfeiting [1].

**Block Complexity (Size and Number):** Supply chain managers must ensure that they include important product life cycle stages and related relevant information for traceability, keeping in mind the supply chain complexities resulting from increased information and supply chain partners [1].

**Information Collection:** Collecting and recording good quality information is a bigger challenge in a complex supply chain. Actors at various supply chain stages are reluctant to share all their crucial information, as they fear more transparency and openness will reveal their trade secrets to their competitors. On the other hand, information collection and recoding can be a tedious process resulting in a lack of employee motivation unless compensated by any incentive [1].

**Human Error:** Human error is always a liability; for traceability, the required data must be recorded and stored at each level of the supply chain. A decrease of quality in information can cause a chain reaction and affect the whole integrity of blockchain [1].

There are many challenges in the implementation of traceability in sustainable supply chains: changing markets and conscious consumer demands require companies to share more information about the products they purchase, including supply sources and supply chain operations. Although blockchain integration has obstacles as well, this new technology enhances supply chain transparency by allowing supply chain managers to obtain the information consumers are demanding while providing compliance data, providing their companies' competitive advantages [10].

## FOREST CERTIFICATION

Forest certification is becoming a significant indicator of corporate responsibility within the forest industry. The forest industry is incorporating more environmentally responsible practices in both the production and purchasing of raw materials. There is growing global concern over illegal logging because it results in the loss of natural resources, environmental damage, and decreased revenue to the forest products industry and governments [5]. Illegal logging has been commonly defined as "when timber is harvested, transported, bought or sold in violation of national laws" [12]. The World Bank estimated in 2006 that illegal logging resulted in US\$5 billion annual loss in revenue for governments and US\$1 billion in annual revenue loss for US companies due to illegal wood products being sold in the market [12].

The ability to track wood materials throughout the supply chain is an important way to illustrate forest industry corporate responsibility. Tracking is heightened when sustainable forest management practices can be confirmed when the forest location and chain of custody certification can be verified [23]. There are several forest certification schemes, the largest and most recognized are the Forest Stewardship Council (FSC) and the Programme for the Endorsement Forest Certification [11].

The FSC forest scheme in 1993 was initially an environmental non-governmental organization, which assisted consumers with identifying products from sustainably managed forests. The FSC

and PEFC developed their chains of custody certification to track and ensure sustainable wood purchasing and forest management systems [23]. The original scope for forest certification was to conserve and preserve the biodiversity of rain forests. However, when you look at the certified forests only 10% of the globe's forests are certified. The incentive for companies to gain certification seems to differ from the certification schemes' primary aim. Scholars suggest that forest certification has been effective in raising environmental awareness for landowners but this awareness doesn't get translated to the consumer [23].

There are two types of certificates: forest management (FM) and chain of custody (CoC). The forest management certificate faces several policy issues like balancing economic, environmental and social concerns for forest management, mitigating illegal harvesting and conserving biodiversity [11]. FM certification is a process whereby forest owners voluntarily submit their forests for inspection by an independent certification body to determine whether their management practices meet defined standards in regards to sustainability [17]. Being FM certified allows for companies to market themselves as being committed to the environment which improves the company's image. FM certification is an important tool for demonstrating a company's corporate responsibility and maintaining a niche in the forest industry.

CoC certification identifies wood and wood-based products originating from sustainably managed forests [17]. CoC certification applies to all organizations that trade, process or manufacture wood-based and non-timber forest products [11]. FSC chain of custody certification verifies that FSC-certified material has been identified and separated from non-certified and non-controlled material as it makes its way along the supply chain from A through B Traceability is a necessity for verifying wood products and their origins throughout the entire supply chain [7].

Although there are numerous governmental policies to reduce illegal logging, there are still challenges seen within the forest industry supply chain to ensure illegal wood does not enter the market. These new policies such as the Lacey Act in the United States are requiring high levels of due diligence for all producers to verify their wood and wood products are sourced legally. One of the major challenges with tracking and certifying wood is the lack of affordable and feasible technology to track wood throughout the supply chain [12]. Blockchain technology can enhance electronic traceability and ensure reliability, transparency, and security for certified raw materials and wood products.

### **WOOD TRACEABILITY STUDIES**

Most blockchain applications are being implemented in the finance sector but supply chain managers recognize blockchain's potential to enhance industrial applications and achieve competitive advantages. The integration of blockchain technology creates opportunities to optimize business processes, in particular, tracing and tracking.

The volume of imported illegal wood increased by over 50% between 2006 and 2013, showing similar difficulties to the blood diamond crisis. To decrease the purchase of blood diamonds from conflict areas the diamond industry has recently integrated blockchain technology to certify and track registered diamonds [7] [12]. Supply chain managers are interested in the possibilities of this new technology because, outside of new compliance regulations, consumers are demanding supply chain transparency. The validity of materials and sourcing concerns are aggravated when supply chains are multi-tiered [10]. Enhanced log and wood tracking would provide multiple

benefits for forest managers and downstream wood product producers [12].

A study conducted by Figorilli et al. introduced the application of blockchain technology for enhancing traceability within a wood supply chain, from a standing tree to the final user [7]. The authors advocated that traceability is important because retailers and importers need to be able to trace products. With the creation of two sustainable forest management certifications in Europe, wood and wood products of illegal origin are prohibited for use and trading. These new regulations initiated a need to certify wood products' origins and the ability to trace products flow through the supply chain. The authors used Radio Frequency Identification (RFID) to reduce information gaps and enable real-time visibility into supply chains. The RFID technology allows for automatic traceability by connecting physical world objects with their virtual equivalents.

This infotracing technique can provide a web interface for product information that is accessible by the manufacturer, wholesaler, reseller, retailer and consumer. The transactions made within the infotracing system can be made immutable to ensure validity through blockchain technology. The entire wood supply chain was simulated in Italy, from standing tree to final product using RFID technology. To create the blockchain technology the application Azure Blockchain Workbench with cloud deployment was employed. Below is the illustration Figure. 1 of the wood infotracing phases and corresponding multi-actors, multi-tags and multi-devices.

**FIGURE 1**

**From Figorilli et al. [7].**

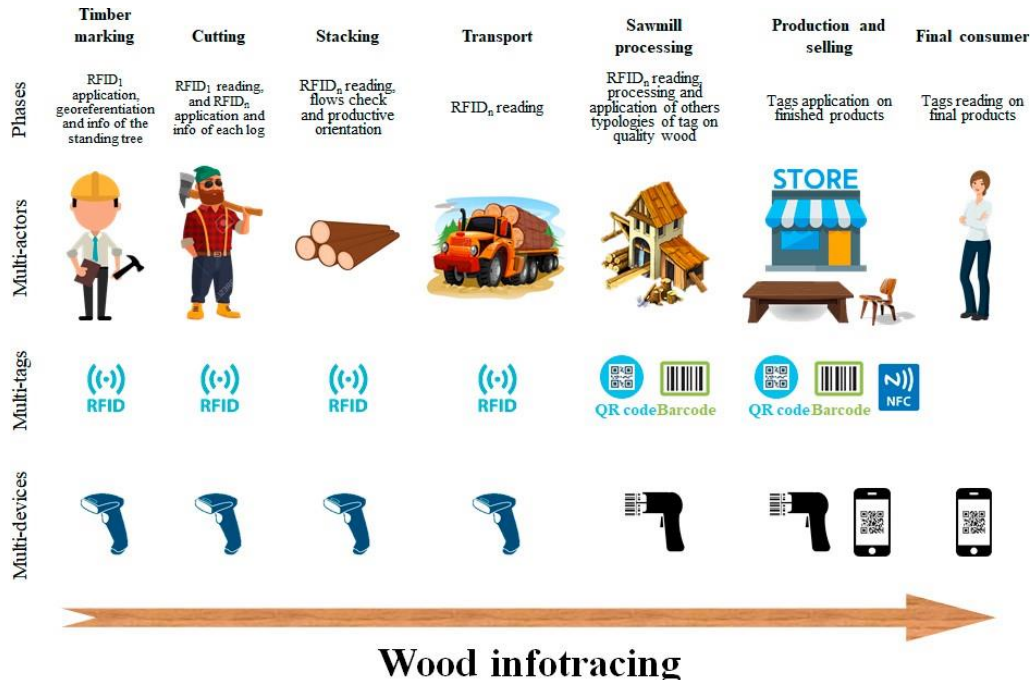

One drawback seen with adopting any new technology is cost, but the authors highlight the need for a new level of transparency and efficiency that must be met to ensure future profits and business operations. A survey conducted asking wood manufacturers about their willingness to pay a premium price for certified wood showed that 30% were willing to pay a higher mean premium price of 2.40%

for certified wooden planks. The results from the survey alleviate the concern for the feasibility and economic sustainability of integrating blockchain technology. An economic evaluation of RFID and open source technologies integration within the forest industry was conducted to evaluate how these technologies could improve streamlining operations and use resources more efficiently [7]. The authors were also confident and anticipative of rapid IT development such that the price of integration and operation of blockchain applications will rapidly decrease.

In a study to find an economically and technically feasible wood tracking method the following characteristics were considered ideal: practical to apply in the field, reliable, cost-effective, easy to read and use, resistant to harsh conditions, compatible with downstream processing, and reusable [12]. In many countries with high levels of illegal logging, oversight is usually low, so an effective tracking method must be difficult to replicate and fraud should be detectable at various points within the supply chain. Combining two log tracking methods, a unique method was proposed using a large-format QR code and applying it on the end of logs using tree marking paint mixed with a high content of microtaggant tracer. Microtaggant identification particles provide multiple levels of security, each particle contains color layers, which translate to a numeric code, giving the paint a unique code such as a fingerprint.

The U.S. Forest Service uses microtaggant to detect illegal logging on their lands and the use of microtaggant would be using The U.S. Forest Service methods as a foundation for the newly proposed tracking method. The use of QR code is ideal because it can hold large amounts of information in a compact format, can be read from various distances and angles. The QR code provides the first level of security, allowing for the code to contain large amounts of information within the tag [12]. The microtaggant provides the second level of security, with the particles containing a unique color code pattern that is difficult to replicate. The third level is seen with paint particle density, particle per unit area within the bar code should meet a certain range if lower inspectors could detect diluted paint and fraudulent activity [12].

QR codes embedded with micro-taggant have been utilized in the medical industry to track counterfeiting medicine, which is fake medicine, that may be contaminated or contain the wrong or no active ingredient [12]. Applying QR code with wood paint embedded with micro-taggant was considered because it meets the characteristics of the ideal wood tracking method, being easily applicable in the field and cost-effective. The applied QR can be input into a cloud-based system that allows for real-time tracking of wood and wood products throughout the supply chain [12]. The QR code can hold large amounts of data such as harvest location and wood species. Smartphone applications have QR code reading technology and could be used by all users throughout the supply chain to verify materials.

To carry out this tracking method, Nelson Gun Type Boundary paint was initially used but once applied to wood cookies (freshly cut wood pieces) the readability of the QR codes was not acceptable. The QR codes were applied using a stencil [12]. The stencil was created using Computer Numeric Control (CNC) machines. The main issue was with the application of the Microtaggant paint with a spray gun; the application was not precise and did not produce hard edges. The paint also bled into areas where it was not wanted. The second problem was the difficulty of applying thick layers with the spray gun, a lack of contrast from the paint and wood made it difficult to read the QR code. Another challenge was the end grain of the wood having inconsistent surface smoothness, the growth rings also altered the paint color creating a contrast



issue for QR code readers. The authors switched paint in an attempt to improve contrast and application by using standard aerosol spray paint (black and navy blue). The readability of the QR codes was significantly higher with the aerosol black navy spray paint. With 100% readability with the iPhone application for the Douglas-fir species cookies [12].

For future studies looking to use this method, the readability of the QR code must be improved. The QR code readability was improved by using aerosol-based spray paint, but the microtaggant particles are too large to be applied through a standard aerosol can. Further experiments must be done to develop a reliable application method. Also, because results differed across tree species, paint application should be modified to suit the tree species' anatomical differences to ensure reliable and applicable QR application. This tracking method was devised to be economically feasible, the paint and Microtaggant mixture cost ranged between US\$46-US\$62. Each paint mixture could mark approximately 200 logs, cost per mark is estimated at US\$0.23-US\$0.31. This cost estimate is based on shelf price and the discounts seen with bulk purchasing were not calculated [12].

In a study focused on developing the use of blockchain-based tracing and tracking methods, from solely tracing product origin and linear movement through the supply chain, to incorporating manufacturing processes. Most solutions utilizing blockchain have been dedicated to simple goods and become obsolete once production processes occur. To enhance the ability of tracking products Westerkamp et al. solution accounts for processing and input goods of the final product [24]. For this method, physical goods are documented as smart contracts and represented as tokens that can contain a product's origin, exchange and transformation processes.

Smart contracts allow for rules and criteria to be enforced without a third party. The smart contract system was created with the Ethereum blockchain and carried out on the Ethereum virtual machine (EVM). Ethereum is a unique decentralized platform that enables the use of smart contracts for the entirety of the blockchain. The activation of subsequent processes is completed by sending a transaction to the contracts address fulfilling the criteria of the contract's parameters. To actively contribute to the blockchain, participants must own ether, which is a unique piece of code that allows updates to the blockchain's ledger. The smart contracts would be written using the programming language solidity, this programming language is suggested in recent Ethereum smart contract-based product tracking systems [24]. Developers that create smart contracts or apps on the Ethereum blockchain must pay ether tokens to host it, while partners who operate within the app pay with tokens to execute transactions. Ether transactions are necessary for the execution of any contract or transaction by the EVM. Price for transactions is defined as gas cost in the Ethereum yellow paper, and key costs are operations that store or change values on the blockchain [24]. The EVM is governed by miners or supply chain partners who verify state changes, by verifying and executing transactions.

The tracing and tracking system utilized smart contracts and represented physical goods in the form of digital tokens and recipes that initiate subsequent steps of production. Recipes allow for the manufacturing process to be represented digitally. This is done by tokens being combined and being transformed into a new token. The recipe allows for supply partners to specify the number of input goods required to produce a new good. Another component of importance is the ability to certify goods within the supply chain. To tokenize goods, smart contracts are created for each type of good managed in the supply chain [24]. Contracts correspond to a product of a

specific partner in the supply chain. For instance, a log supplier could only create log contracts, it could not create a board or chair contract, which are subsequent and different stages of the supply chain. The smart contract encompasses tokens that represent physical goods. One token represents one batch of goods that could be measured in quantity, weight, volume size or other general product information. Tokens are unique, which allows users to identify batches of the same type of good.

To represent the production process, tokens can be transformed into new tokens, which are referenced as a recipe for good transformation [24]. Along the supply chain, the following partner in the supply chain can determine what tokens (inputs) and the number of tokens are required for a new contract (new product). For the execution of the smart contract, the specific amount of input tokens needs to be specified by the subsequent partner in the supply chain. Contracts can require functions such as certification to act as inputs in the recipe for the manufacturing process. Certification function allows for goods to come from different regions, but meet the same compliance standards i.e. forest certification [24] [23]. If a recipe calls for certification and the tokens are not certified, the recipe will not be carried out, which means a new contract is not created and the function reverses. If the recipe is fulfilled then a new contract can be created by the subsequent partner in the supply chain, and the batch tokens are transferred with contract creation.

Participants in the smart contract system can perform one or more roles. The authors provided a list of roles representing the edged glued wood manufacturing process, they are listed with their description and input to the supply chain in Table 1 [24]. The resource suppliers create goods without inputs, they can split or merge batches before they are transferred to other participants in the supply chain. Producers require inputs to create goods, the digital process of these physical goods being acquired is done by transferring tokens. The producer becomes the owner of the transferred tokens, these transferred tokens are required to create a new token, following a recipe. Producers can also split or merge batches before they are transferred to other participants in the supply chain. Logistics and retail entities get good tokens transferred to them but do not modify or create goods. They can also split or merge batches before they are transferred to other participants in the supply chain. Consumers receive and utilize a product. At this step, the token batch is deleted and is no longer in the supply chain, but the production process can still be verified, in most cases the origin is traceable. Certifiers verify the quality of multiple goods, issuing a certificate. Assuring that specified standards are met, i.e. sourcing. A standard authorizing organization could act as the certifier, i.e. coalition or government agency. This entity does not own, create or acquire tokens [24].

**TABLE 1**

**Role definitions and processes as described in Westerkamp et al. [24].**

Resource Suppliers: Forester and Glue Plant	Creates good without inputs: The forester and glue plant transfer batches of logs and glue to the sawmill.
---	--

Producers: Saw Mill/Factory	Requires inputs to create goods: The sawmill/factory acquires tokens (batches) of logs and glue from the resource suppliers. Sawmill/factory can produce an edged glued wood token (batch). This is done by satisfying the edged glued wood token recipe, calling for 'x' amount of log tokens and 'y' amount of glue tokens.
Logistics and Retail	Acquires tokens but does not modify goods nor creates goods. Tokens (batches) can be split or merged. A token of 100 units could be split amongst multiple retailers, or a wholesaler could merge tokens (batches).
Consumers	Receive and utilizes product, the token batch is deleted and not a part of the supply chain, but origin can still be verified
Certifiers	Verifies the quality of multiple goods, issuing a certificate. Does not own, create or acquire tokens. Would verify that the logs were sourced from a forester that, meets specified guidelines. Certificates can be required for recipes, only log tokens that have received certification can be utilized in the edged glued wood token creation.

The traceability of a manufacturing process is imitated digitally on the blockchain. The process of inputs being required for subsequent steps in the supply chain is reflected, contract creation is only executed if the recipe is fulfilled (correct quality and/or quantity inputs required). This allows for every step in the manufacturing process to be captured and reflected, allowing for traceability of single products and their inputs. The blockchain can also record other variables of interests such as location and timestamps, to provide further traceability measures [24]. Products are usually shipped and processed as batches so that a batch of edged glued wood could be traceable to a batch of logs.

To illustrate this smart contract system the authors use an example following an edged glued wood manufacturing process, see Figure 2. The executions for minting and token transfers were simplified, with product batches being represented as unique data structures that store quantity needed for inputs in the manufacturing process. Each batch reflected one token with these unique features, remembering that batches are represented as tokens. The smart contract method following the edged glued manufacturing process has three participants in the supply chain, with six steps identified. The supply chain process of the manufacturing of the edged glued wood go as follows [24]:

1. Token contracts are created by the resource suppliers; the forester's token contracts hold the log batches and the glue plant's contracts hold the glue tokens.
2. The certifier approves the forester's log tokens by confirming specific criteria have been satisfied.
3. The sawmill requires two inputs: certified log tokens and glue tokens. The set standards allow for the sawmill (producer) to have multiple resource suppliers. While inputs may have different origins, the producer requires inputs to comply with specific standards or be a specific product. To better explain the author's example, the log tokens must be certified, and the glue tokens must be a specific type of glue.
4. The batch of 10 logs and the batch of 5 glue are sent to the sawmill, this execution is triggered in the transfer function.
5. To create a batch of edged glue, the sawmill must define the amount of log and glue used for production. The add-batch function initiates by querying if the log tokens have been certified, which is done by confirming the certifier's certificate contract. If certification is positive, the logs are consumed, the logs' token's consumption function is called, the overall logs held in the foresters contract are reduced and the sawmill now owns those corresponding tokens. The add-batch function uses the glue tokens instantly since the glue tokens are defined and there are no certificate criteria.

Following the process of Figure 2, the sawmill received 10 log tokens and 5 glue tokens; to produce 1 edged glued wood, 1 log token and 5 glue tokens were required. After the production of 1 edged glued wood, the sawmill had 9 log tokens and 0 glue tokens leftover. Westerkamp et al., 2019 developed a mobile and web application to facilitate the database for existing goods and the creation of new goods.

**FIGURE 2**

**Westerkamp, Martin, et al. the production process along the supply chain reflected by smart contract and token transfers [24].**

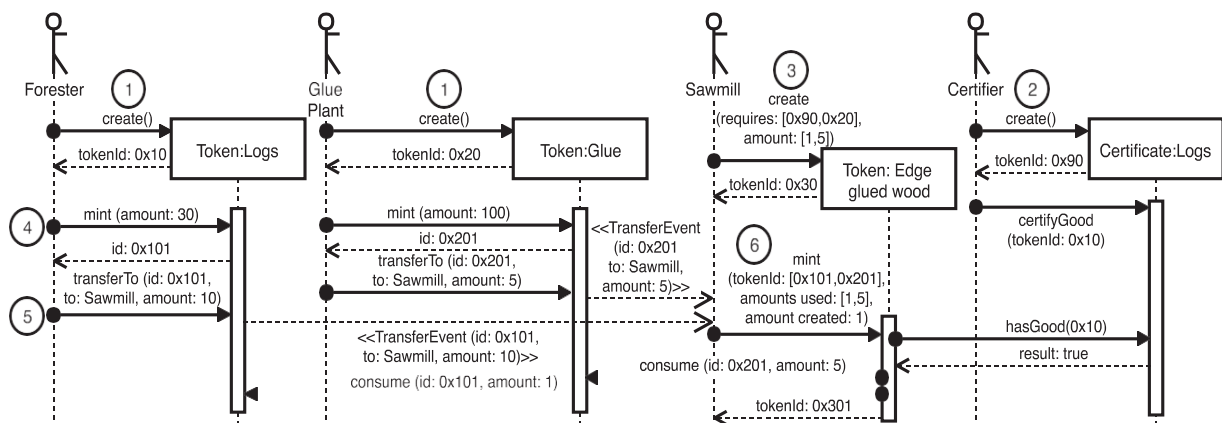

These three reports and their methods will be used to construct an ideal wood tracking system for this use case study. The methods and systems proposed will be modified and built upon to better suit the supply chain and products being tracked. The key contributions in this paper are as follows:

1. Design a supply chain traceability system that verifies certified wood throughout the supply chain integrating blockchain technology.
2. Present a prototypical implementation.
3. Evaluate the implementation.

### **INTRODUCTION TO CASE STUDY THE LOWE'S COMPANIES, INC.**

The Director of Corporate Sustainability at the Lowe's Companies, Inc. identified that Lowe's started sustainability initiatives with the 'supplier management for risk and performance' strategy. Their initiatives, like those of many other companies, were directed towards minimizing PR issues within the supplier base, and the company has been doing that for quite a long time. Currently, Lowe's is evolving into a firm for sustainable products. Their initial strategy was "do no harm" and now it's "do better." The driving question for the company now is: How can we take the products we sell and make them better for the world? Lowe's practices formalization supply chain governance. Due to their large number of suppliers, other forms of governance would be too difficult to execute to a high standard. The monitoring of supplier performance through audit evaluations directly impacts the strength of sustainability metrics and goals. The Director of Corporate Sustainability indicated that a supplier who performs poorly in their audit, will not be reassigned once their contract is up. In this study blockchain technology will be integrated within the Lowe's Company Inc. supply chain to track wood products at any point in the supply chain to identify and verify sustainably certified wood. Forest certification is gaining popularity and is becoming an indicator of a company's commitment to responsibility, while also providing the satisfaction of supporting the sustainability of natural forest resources for stakeholders and consumers [17]. CoC certification represents heightened supply chain management and the integration of blockchain technology will provide a new level of transparency to offer greater confidence in transactions and wood verification.

There are two approaches to improving supplier (or supply chain) sustainability within a company: a broad approach or a product-specific approach. The broad approach can be implemented throughout an entire supply chain comprised of many partners. Walmart's ambitious gigaton initiative is a well-acknowledged successful broad approach to improving sustainability. Project Gigaton is a Walmart initiative to reduce the company's greenhouse gas emissions throughout its global supply chain [19]. This initiative is set to avoid one billion metric tons (a gigaton) of greenhouse gases from the global value chain by 2030. Through Project Gigaton, Walmart suppliers can take their sustainability efforts to the next level through goal-setting, and get credit from Walmart for the progress they make. Since the program was introduced in 2017, hundreds of Walmart suppliers have gotten on board by committing to reduce emissions.

One of the unique traits of this large-scale sustainability initiative is Walmart's aim to keep the price of enhancing product sustainability out of the customer's pocket. Walmart intends to bring

sustainable products to the price-conscious consumer. Their strategy aims to make sustainability a public good, shifting the notion that sustainably sourced and produced products need a hefty price tag for verification. Walmart is working with suppliers, assisting them in adopting energy-efficient operation practices, i.e. energy-efficient light bulbs, clean energy, and other greenhouse gas reducing steps. This broad-based strategy for implementing sustainability is easier than the product-specific approach.

The product-specific approach to sustainability is carried out by focusing on one product or product category, analyzing the products' life cycle to make improvements to safety or sustainability. Taking the product-specific approach utilizes more resources and requires more work, but can be more effective than the broader approach. For this case study, a product-specific approach will be taken to enhance the traceability of wood along the supply chain, using blockchain technology as a tool to improve assurance of the legality of timber origin.

**What is known:** Wood tracking is a growing interest in the forest industry and accurate and secure tracking would present multiple benefits for both forest managers and all downstream wood product producers. Major consumer countries are requiring wood product sellers to validate the origins of their raw wood and wood products. There is no method currently being used to track large quantities of wood and wood products throughout the supply chain that is both technically and economically feasible. Blockchain can increase transparency and accountability along a wood supply chain.

**What we want to know:** Can wood be accurately tracked throughout the supply chain to verify certified wood using a technical and economically feasible tracking method? Can blockchain technology be integrated to enhance traceability and verify certifications of wood along the supply chain?

### **LOWE'S USE CASE EXAMPLE**

As Lowe's strengthens its substantiality initiatives, enhancing the ability to provide traceability of goods, such as wood empowers the growing number of consumers who have interests in products that were sourced and produced with ecological and ethical integrity. Blockchain technology presents a level of transparency and accountability along the wood supply chain that is not achieved with the current conventional centralized database. Methods from the three reviewed case studies will be integrated into this study to produce an improved, economical and reliable tracking method [7] [12] [24].

The following use case proposes the implementation of a multi-level security tracking system with microtaggant paint and a blockchain decentralized supply chain management system based on smart contracts in a wood supply chain. Incorporating the microtaggant paint in the initial transfer from certified forest to the sawmill will provide insurance of verifiability of certified logs. To account for the processing of wood throughout the supply chain, the physical goods will be represented as digital tokens and recipes to initiate the subsequent process in the manufacturing process. A web-based application will be utilized for in-field data readings, facilitate token detection of existing goods, creation of tokens and the ability to see previous token inputs and transactions. The wood processing phases and supply chain partners roles are depicted in Figure 3 and Table 2.

**MODEL COMPONENTS**

**Wood traceability phases**

**FIGURE 3**

**Wood traceability phases and digital representation with smart contract and token transfer through the manufacturing process [24].**

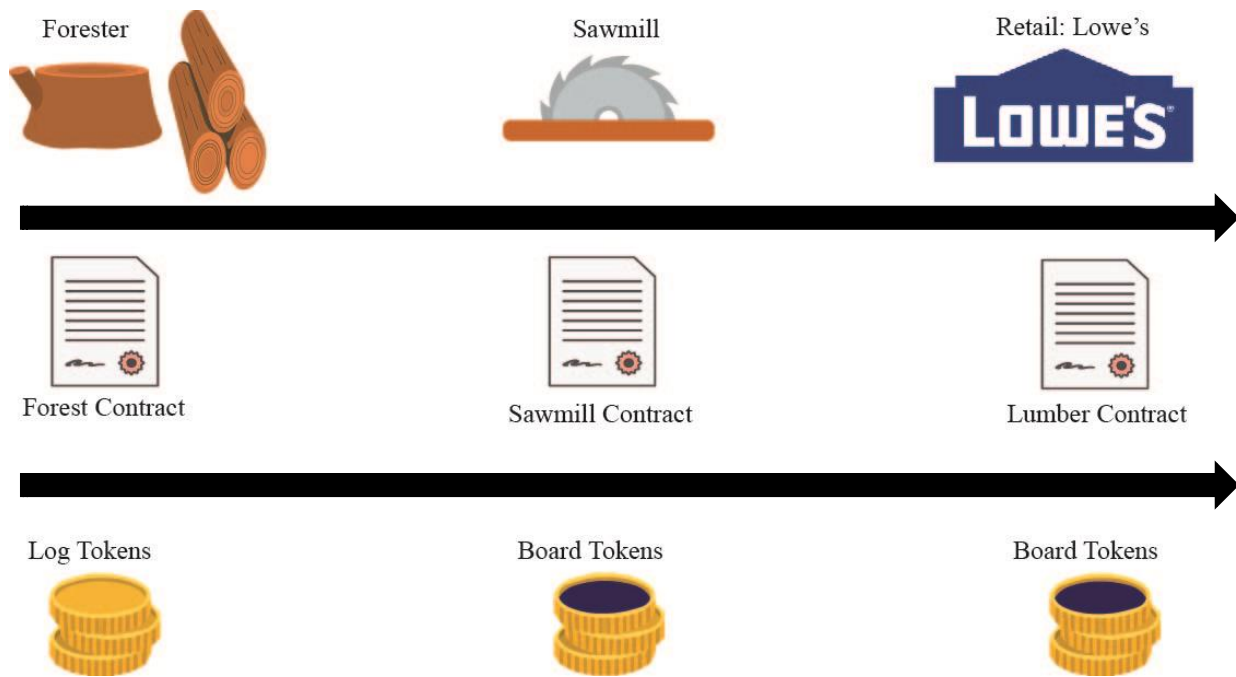

**Table 2**

**Role descriptions and actions defined of the use case [24].**

Roles	Description
Resource Supplier: Forester	Creates forest smart contract that holds log token contracts. Forester is certified, with microtaggant paint, logs will be marked to identify certification. Transfers batches of log to the sawmill

Producer: Sawmill	The sawmill acquires tokens (batches) of logs from the forester. Sawmill can produce a board token (batch). Once the logs are scanned to match the microtaggant QR code, the log tokens are instantly transferred to the sawmill.
Retail: Lowe's	Acquires tokens but does not modify goods nor creates goods

### Microtaggant tree/log marking

Logs will be marked using microtaggant paint and QR code technology. Timber marking: application of the QR code will be painted using microtaggant mixed paint. Microtaggants are microscopic particles that contain multiple color layers, which translate to a numeric code. The QR code stencil can be generated using a 3-D printer. The use of QR code is ideal because it can hold large amounts of information in a compact format, can be read from various distances and angles, they can also be generated for free. The QR code provides the first level of security, allowing for the code to contain large amounts of information within the tag and facilitating the wood certification verification process. The QR code associates the information on the database of the token: tree marking date, tree GPS point, species, cutting date, and can be further developed to include log length, log average diameter, wood quality categories, and other useful information. This method will function as a certificate, logs marked with microtaggant paint will hold certification of being harvested from a certified forest.

The microtaggants can be enhanced to aid in location and authentication, to support in recording data into the blockchain application. The security of microtaggants reduces the ability to replicate markings and cheat the system. The microtaggant provides the second level of security for the wood origin verification, with the particles containing a unique color code pattern or density that is difficult to replicate. Microtaggant paint can be purchased from MicroTrace LLC, due to paint application issues seen with the Knowles et al study, the Microtaggant Airbrush System is proposed [12]. This system enables the ability to assign a unique code for each of their distributors, in this use case it would be foresters. The unique distributor Microtaggant code is applied to the exterior of the logs before hauling of log batch to the distributor/sawmill.

MicroTrace LLC, Minneapolis, Minnesota, USA provided an informational flyer on the Airbrush System, here are the following descriptors and pricing information.

The Microtaggant Airbrush System includes application instructions and 8-ounce containers with a clear carrier material for airbrush application. Each 8-ounce container contains enough Microtaggant Identification Particles to mark approximately 8,400 bottles. Desired density and operator application can impact the number of products covered by each container using the Airbrush System. To operate the system, you will need airbrush glass bottles, sprayers, and a compressor. MicroTrace recommends using Badger Airbrush products: These items can be purchased from MicroTrace or Badger Airbrush. Glass bottle and sprayer (model number 250-4) Compressor (model number 180-11)."

Pricing information One-time Certification and Registration for all unique company codes - \$5,000. With a minimum initial order: 100 – 8oz containers and minimum reorder: 20 – 8oz containers



If a third level of security is desired, this would be applicable in regions that experience high levels of fraud, UV particles can be added to the microtaggant paint. Microtaggants enable employees or investigators to do on-the-spot, non-destructive field testing with inexpensive and handheld detectors. Detectors for microtaggants are 980nm Laser Pen, 365w UV Light, Dino Light USB Microscope Handheld Microscope, Microtaggant Identification Particles can also be viewed using standard stereo microscopes.

## **BLOCKCHAIN TECHNOLOGY**

### **Representing physical goods with smart contracts and tokens**

Each partner within the supply will set up a smart contract for the good they manage in the supply chain. The forester, the sawmill and Lowe's will have smart contracts set up for their corresponding good(s). Within the smart contracts, tokens that represent physical goods, one token represents one batch of goods that could be measured in quantity, weight, volume size or other general product information. Tokens are unique, which allows users to identify batches of the same type of good [24]. To represent the production process, tokens can be transformed into new tokens, which is referenced as a recipe for good transformation [24]. Along the supply chain, the following partner in the supply chain can determine what tokens (inputs) and the number of tokens are required for a new contract (new product). In this case, the sawmill requires a certain amount of microtaggant marked log tokens to satisfy recipe for board tokens i.e. you need 10 log tokens (3 log units) to create 1 board token (250 board units).

Forester -> Log Contract -> Log Tokens: Tree species, location, quantity

Sawmill -> Board Contract -> Board Tokens: Data from log token, quantity

Lowe's -> Lumber Contract -> Data from board token (which encompasses the log token data), quantity

### **Web and mobile application**

An application accessible on the web or a smartphone will be implemented to enhance the wood traceability data collection, by supporting in-field collections of microtaggant QR scans, storing existing goods and creating new types of goods with existing goods. Users will be able to identify the number of tokens in their possession. The app can produce QR codes for specific batches with new good creations. For example, if you have a token (batch) of 10 logs and the retailer only needs 5, you can create a new token (batch) of 5 logs in addition to generating a QR code specific to that token (batch) [24]. Generating QR codes would be ideal with the completion of the last step in the production process. As goods get modified, the QR code could be damaged or erased. Tokens inputs, token creation and token history of transactions would be accessible through the app, providing trackability of products [24]. With the specific QR code being generated for tokens, once scanned the QR code can reveal the components used for the manufacturing of the final product, while also revealing information about the origin or other necessary consumer standards.

### **Proposed blockchain platform and utility**

The blockchain platform proposed to build the blockchain network is the Azure Blockchain.

Azure Blockchain was chosen because it simplifies development and eases experimentation due to its prebuilt networks and infrastructure [18]. Developing cost and time are reduced using the Azure Blockchain Workbench with prebuilt integrations to the cloud services needed for application development. The software can also be easily integrated with existing systems and ERPs. Another key feature of this platform is its support of Ethereum smart contracts written in Solidity language. Ethereum is a unique decentralized platform that enables the use of smart contracts for the entirety of the blockchain. Azure Blockchain also deploys the ability to integrate IoT devices directly using an Azure IoT Hub, which supports the security of IoT devices with the ability to be directly integrated with the blockchain application. The development of applications is done by writing a JSON configuration file and a smart contract, which is executed by the application logic.

The Azure Blockchain Service is deployed through the Azure portal, Azure CLI, or through Visual Studio, code using the Azure Blockchain extension. With provisioning of both transaction and validator nodes, Azure Virtual Networks for security isolation as well as service-managed storage, the deployment process is simplified. Another feature that simplifies the blockchain construction process is when new blockchain members are added, the users also create, or join, a consortium. Consortia enable multiple parties in different Azure subscriptions to be able to securely communicate with one another on a shared blockchain. This simplified deployment reduces blockchain network deployment from days to minutes [18]. This platform allows users to investigate the events in the blockchain by automatically synchronizing data on the blockchain to off-chain storage. This gives the user the ability to query an off-chain database system, versus high energy consumption of extracting data directly from the blockchain.

A Full Azure Blockchain deployment includes [18]:

- App Service Plan (Standard)
- Application Insights
- Event Grid
- Azure Key Vault
- Service Bus
- SQL Database (Standard S0) + SQL Logical Server
- Azure Storage account (Standard LRS)
- Virtual Machine scale set with a capacity of 1
- Virtual Network resource group (with Load Balancer, Network Security Group, Public IP Address, Virtual Network)
- Optional: Azure Blockchain Service (Basic B0 default)

An application for smartphones/tablets will be developed to increase accessibility to the blockchain and support traceability data collection and in-field data collection. The application will be utilized for scanning in the microtaggant QR code and will be linked to the blockchain system with all registered information being stored in the database. Another function of the application will allow for blockchain users' to search for existing goods associated with their supply chain. If necessary the user can also generate a new QR code for individual product batches, this is convenient when token holders are splitting or combining batches to fulfill an order, ensuring the integrity of transparency of good origins and process through the supply chain. During

all synchronization processes, the application and blockchain will audit the database to prevent the use of already claimed tokens for recipes, splitting or combining. The audit will also prevent the duplication and unauthorized use of tokens, if any attempt is flagged, all users of the supply chain will be notified. All product batches stored can be queried for inputs and production processes, allowing for transparency and traceability at any stage during the supply chain.

Internet connectivity is necessary for the application to successfully synchronize information and provide an accurate representation of real-time supply chain processes and transactions on the blockchain.

## IMPLEMENTATION

To enhance the traceability and verify certifications of wood along the supply chain, the use case proposes the implementation of a multi-level security tracking system with micro-taggant paint and a blockchain decentralized supply chain management system based on smart contracts in a wood supply chain. Incorporating the microtaggant paint in the initial transfer from certified forest to the sawmill will provide insurance of verifiability of certified logs. To account for the processing of wood throughout the supply chain, the physical goods will be represented as digital tokens and recipes to initiate the subsequent process in the manufacturing process. A web-based application will be utilized for in-field data readings, facilitating token detection of existing goods, creation of tokens, and the ability to see previous token inputs and transactions.

To illustrate the method and keep the transactions simplified three partners of the supply chain are depicted with five steps along the supply chain. This simplistic example is used to extenuate the main execution of method Figure 3. A more complex production process could also be used, with the addition of a supply chain producer partner. The partners of the supply chain and their activity within the supply chain following the traceability method follow these steps:

1. Trees in a certified forest are harvested. The ends of the logs are tagged with a QR code using the stencil and microtaggant paint. The QR code will house tree location, season and species. This will act as the certification necessary to create the log token.
  - a. The forester supply chain partner will sign into the blockchain app via phone/tablet. The main screen will have 3 options: “resource supplier”, “producer” and “retail”. The forester supply chain partner will choose “resource supplier”, the next screen will have names of approved certified forest suppliers, and the user will choose their forest. The user will be prompted to provide a user ID unique to the supplier. The user will verify the microtaggant and QR code by scanning the QR code and verifying the microtaggant which will satisfy 2/3 of the token contract. The last part of the token contract will be verified with the blockchain’s app ability to record/verify the location of data inputs.
2. The resource supplier; the forester creates a log contract once the microtaggant QR code is recorded and the location is verified. Within the log contract, token contracts are created to represent batches of logs. The token contract reflects a batch of 60 logs. The physical logs are transported to the lumber yard. The created token batch is sent to the sawmill and is notified through the execution of the transfer contract function.

3. The physical logs arrive at the sawmill.
  - a. The producer supply chain partner will sign into the blockchain app via phone/tablet, main screen and will have 3 options: “resource supplier”, “producer” and “retail”. The forester supply chain partner will choose “producer”, the next screen will have names of Lowe’s producers, the user will choose their company. The user will be prompted to provide a user ID unique to the producer. The user will verify the microtaggant and QR code by scanning the QR code and verifying the microtaggant which will satisfy the recipe for the creation of a board token contract.
  
4. To create a batch of boards, the sawmill must define the number of logs used for production. The add-batch function will verify that the logs have been marked with microtaggant QR code, scanned, verified twice (1<sup>st</sup> scan at the forest and 2<sup>nd</sup> scan at the sawmill), and the initial scan was recorded in a certified origin. Upon the verification of origin and microtaggant QR code, the logs are consumed, the logs token's consumption function is called, the overall logs held in the forester’s contract is reduced and the sawmill now owns those corresponding tokens.
  - a. Token transfer the forester holds thirty units of logs and the sawmill holds two units of logs and four units of boards ( $30 \div 7 = 4$  whole units and 2 leftover)
  - b. Board units corresponding to the board tokens could be marked or labeled with generated QR code from the blockchain web application, this QR code will reveal components of the product, in this case, the origin of the logs (a certified forest).
  
5. Board tokens are acquired by Lowe’s. Before the transaction is approved, the Lowe’s lumber contract verifies that the board token is a product of certified log tokens, resulting in the ability to verify the origin of the board or at least its certification status.
  - a. Physical boards are housed at Lowe’s warehouse/store, the board tokens batch information can be accessed on the blockchain web application. A label to be displayed on the price tag of boards could have a generated QR code from the blockchain web application, this QR code will reveal components of the product, in this case, the origin of the logs (a certified forest).

Algorithm: (in progress)

#### **FIGURE 4**

**Use case algorithm depicted by blockchain execution.**

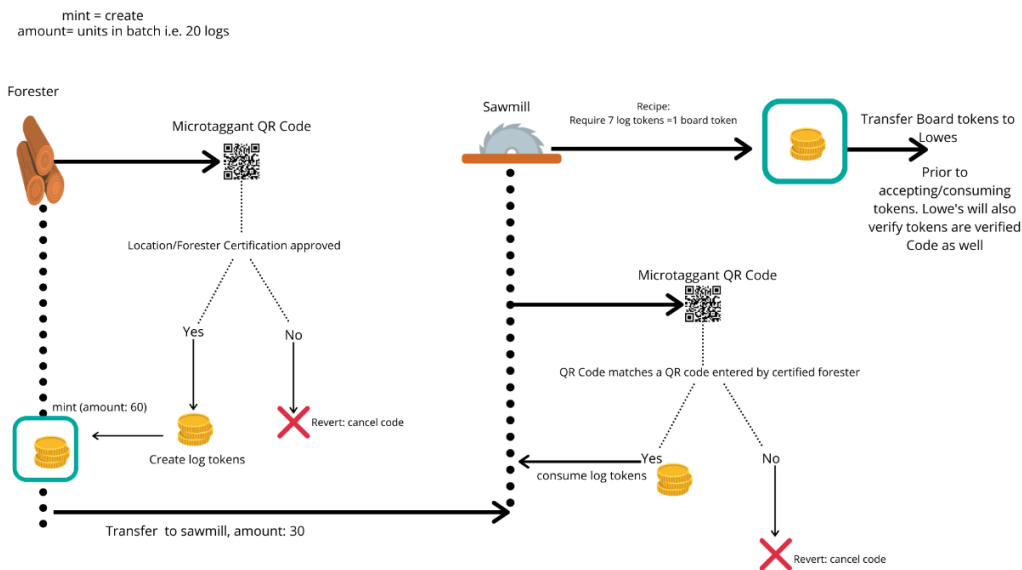

## EVALUATION

This use case provides a potential method of integrating blockchain technology to successfully track and verify certified wood throughout the supply chain. The conceptual model does have limitations that require further research to increase confidence for implementation. Technical guidance was not presented in this paper and further explicit instructions are necessary for coding and blockchain architecture. This theoretical method does provide utility but it also creates questions about the function, deployment and real-life application.

### Blockchain costs

One technique sustainability-oriented companies have been employing is enhancing traceability within their supply chains. Blockchain technology does present the opportunity to strengthen traceability but it also requires energy to operate, secure and execute this priority. There is a need to incorporate sustainable energy management, which provides a holistic overview of the costs associated with blockchain technology (air emissions, fuel use, and hazardous emissions) [13]. With the smart contract tracking system, there is a cost within the blockchain platform associated with the execution of transactions along with the blockchain. Another costly feature is storing data and other variables of the blockchain system. Westerkamp et al. presents the opportunity to utilize the Ethereum Request for Comments (ERC) 721, which provides developers with technical guidance for construction. They present several ways to optimize storage and reduce the costs of executing transactions and storing data along the block [24]. The explicit concerns of energy costs for blockchain will be alleviated, with the shift of organizations adopting more efficient and renewable energy sources, these shifts can allow for sustainable integration and execution of blockchain technology [7] [13].

### Integration of blockchain to existing systems

To conduct an empirical pilot test of this tracking method, producers within a selected lumber supply chain will agree to integrate the blockchain integration into their existing systems. In addition to taking on the additional responsibility of scanning in the microtaggant QR code, during lumber transactions amongst foresters and sawmills. This can be a major challenge but parties are assumed to have high motivation and willingness to implement the technology, thus why they were selected for the empirical pilot test. Blockchain adaptation will also be a cultural change from centralized to a decentralized network that might require additional investment in human resources [1].

### **Sawmill separation of certified and uncertified wood**

One major challenge that may hinder the potential for the tracking method to be executed flawlessly, is the potential for “contamination” at the sawmill. Supply chain partners would have to be conscious and attentive if they procure non-certified lumber, to ensure that the tokenized and certified lumber is not mixed or lost with non-certified lumber. Human error is a significant factor and is always a liability. The information inputted into the blockchain must have priority of accuracy by all supply chain partners. This is also the case for the sawmill and other producers, an error in storage or mixing of non-compliant items can decrease the quality of information and can cause a chain reaction and affect the whole integrity of the blockchain.

## **DISCUSSION AND OUTLOOK**

### **Significance**

The results supply Lowe’s Companies, Inc. with theoretical and conceptual evidence of utilizing blockchain technology to track and verify certified wood along the supply chain. The conduction of this study has identified the feasibility and efficiency of tracking and tracing wood products as well as employing blockchain technology into a product supply chain. This case study can become a foundation for future blockchain implementation for product supply chains and support corporate sustainability initiatives by enhancing products traceability and transparency.

### **Further research direction**

Future research needs to be interdisciplinary and multilevel, due to the many factors and actors needed for successful implementation. Potential supply chain partners may have constraints in regards to integrating, executing or properly utilizing the blockchain technology. Thorough blockchain technology investigation is necessary to develop a threshold for energy use, to ensure that other sustainability initiatives are not threatened, i.e. energy use concerning greenhouse gases.

## **CONCLUSION**

This use case provides a potential method of integrating blockchain technology within the Lowe's Company Inc. to enhance traceability and verify wood certification along the supply chain. The tracking system employs a multi-level security tracking system with microtaggant paint and blockchain technology beyond simple ledgers with the use of processes being represented as smart contracts. Smart contracts facilitate efficiency in transactions by eliminating or reducing the amount of manually intensive tasks. Wood and its subsequent products through the manufacturing process can be stored and secured on the blockchain. The conduction of this study has identified the feasibility and efficiency of tracking and tracing wood products as well as employing

blockchain technology into a product supply chain. The method and strategy supply Lowe's Companies, Inc. with theoretical evidence of utilizing blockchain technology and encourage additional pilot studies for enhancing other product traceability and transparency.

### ACKNOWLEDGMENT

Lowe's Inc. sustainability department and lumber supply chain partners have guided the applied research and information for this study. I wish to express gratitude to all the personnel who provided valuable and constructive comments on the use case.

### REFERENCES

1. Agrawal, Tarun Kumar, et al. "Blockchain-Based Secured Traceability System for Textile and Clothing Supply Chain." *Artificial Intelligence for Fashion Industry in the Big Data Era Springer Series in Fashion Business*, 2018, pp. 197–208., doi:10.1007/978-981-13-0080-6\_10.
2. Azevedo, Susana Garrido, and João Carlos Oliveira Matias. *Corporate Sustainability: the New Pillar of the Circular Economy* Chapter 1. Nova Publishers, 2017.
3. Dai, Hongyan, et al. "A Design Method for Supply Chain Traceability Systems with Aligned Interests." *International Journal of Production Economics*, vol. 170, 2015, pp. 14–24., doi:10.1016/j.ijpe.2015.08.010.
4. dos Santos, Bruno Miranda, et al. "Performance Evaluation of Green Suppliers Using Entropy-TOPSIS-F." *Journal of Cleaner Production*, vol. 207, Jan. 2019, pp. 498–509. EBSCOhost, doi:10.1016/j.jclepro.2018.09.235.
5. Düdder, Boris, and Omri Ross. "Timber Tracking: Reducing Complexity of Due Diligence by Using Blockchain Technology." *SSRN Electronic Journal*, 2017, doi:10.2139/ssrn.3015219.
6. Engert, Sabrina, et al. "Exploring the Integration of Corporate Sustainability into Strategic Management: a Literature Review." *Journal of Cleaner Production*, vol. 112, 2016, pp. 2833–2850., doi:10.1016/j.jclepro.2015.08.031.
7. Figorilli, Simone, et al. "A Blockchain Implementation Prototype for the Electronic Open Source Traceability of Wood along the Whole Supply Chain." *SENSORS*, vol. 18, no. 9. EBSCOhost, doi:10.3390/s18093133. Accessed 11 Feb. 2019.
8. Forest Stewardship Council. "Chain of Custody Certification (FSC-STD-40-004)." *FSC International*, ic.fsc.org/en/fsc-system/current-processes/chain-of-custody-certification-01.
9. Formentini, Marco, and Paolo Taticchi. "Corporate Sustainability Approaches and Governance Mechanisms in Sustainable Supply Chain Management." *Journal of Cleaner Production*, vol. 112, 2016, pp. 1920–1933., doi:10.1016/j.jclepro.2014.12.072.
10. Francisco, Kristoffer, and David Swanson. "The Supply Chain Has No Clothes: Technology Adoption of Blockchain for Supply Chain Transparency." *Logistics*, vol. 2, no. 1, 2018, p. 2., doi:10.3390/logistics2010002.
11. Klarić, Kristina, et al. "An Exploratory Assessment of FSC Chain of Custody Certification Benefits in Croatian Wood Industry." *Drvna Industrija*, vol. 67, no. 3, 2016, pp. 241–248., doi:10.5552/drind.2016.1540.
12. Knowles, C., et al. "A New Method for Tagging and Tracking Logs." *International Forestry Review*, vol. 19, no. 3, 2017, pp. 294–305., doi:10.1505/146554817821865036.

13. Kouhizadeh, Mahtab, and Joseph Sarkis. "Blockchain Practices, Potentials, and Perspectives in Greening Supply Chains." *Sustainability*, vol. 10, no. 10, 2018, p. 3652., doi:10.3390/su10103652.
14. Maxeiner, Lukas Samuel, et al. "Blockchain in the Chemical Industry." *Frankfurt School of Blockchain Center*, Sept. 2018.
15. Monks, Robert A.g. "Creating Value Through Corporate Governance." *Corporate Governance*, vol. 10, no. 3, 2002, pp. 116–123., doi:10.1111/1467-8683.00277.
16. Nair, Anand, et al. "Strategic Purchasing Participation, Supplier Selection, Supplier Evaluation and Purchasing Performance." *International Journal of Production Research*, vol. 53, no. 20, Oct. 2015, pp. 6263–6278. EBSCOhost, doi:10.1080/00207543.2015.1047983.
17. Paluš, Hubert, et al. "HOW COMPANIES IN THE WOOD SUPPLY CHAIN PERCEIVE THE FOREST CERTIFICATION." *Acta Facultatis Xylologiae Zvolen res Publica Slovaca*61.1 (2019): 155-65. *ProQuest*. Web. 23 June 2019.
18. Microsoft Corporation, Redmond, WA, USA. "Azure Blockchain Workbench Overview." *Azure Blockchain Workbench Overview | Microsoft Docs*, docs.microsoft.com/en-us/azure/blockchain/workbench/overview.
19. "Project Gigaton." *Walmart Sustainability*, [www.walmartsustainabilityhub.com/project-gigaton](http://www.walmartsustainabilityhub.com/project-gigaton).
20. Roberti M., 2010. Wal-Mart takes a new approach to RFID. Available from: (<http://www.rfidjournal.com/article/articleview/7756/1/2/>) (Accessed 3.27.2019.).
21. Sousa, R., & Voss, C. A. 2008. Contingency research in operations management practices. *Journal of Operations Management*,26(6), 697-713. doi:10.1016/j.jom.2008.06.001
22. Spicer, Andrew, and David Hyatt. "Walmart's Emergent Low-Cost Sustainable Product Strategy." *California Management Review*, vol. 59, no. 2, Winter 2017, pp. 116–141. EBSCOhost, doi:10.1177/0008125617695287
23. Tuppuru, Anni, et al. "Forest Certification and ISO 14001: Current State and Motivation in Forest Companies." *Business Strategy and the Environment*, vol. 25, no. 5, 2015, pp. 355–368., doi:10.1002/bse.1878.
24. Westerkamp, Martin, et al. "Tracing Manufacturing Processes Using Blockchain-Based Token Compositions." *Digital Communications and Networks*, Jan. 2019. EBSCOhost, doi:10.1016/j.dcan.2019.01.007
25. Yermack, David. "Corporate Governance and Blockchains." *Review of Finance*, 2017, doi:10.1093/rof/rfw074.



RUNNING HEAD: IS AGRICULTURE A SUSTAINABLE

Is Agriculture a Self-Sustainable Form of Income for Mid-Sized Farms in South Carolina?

Ashley Gandy

Carson Ward

David Franck

Francis Marion University

## IS AGRICULTURE A SUSTAINABLE

### Abstract

Maslow's Hierarchy of Needs describes our most basic needs as humans as food, water, air, clothing, and shelter. Without these things, we do not move to the next level of needs. Our society must have these factors before we care about anything more. Some of these needs, such as air are everywhere and free-flowing, but the majority of these needs take work to create.

Production of agricultural goods is a pillar of our economy that allows for us to keep advancing.

Our study examines several factors and attempts to answer the question: "Is agriculture a self-sustainable form of income for mid-sized farms in South Carolina?"

---

## IS AGRICULTURE A SUSTAINABLE

### **Introduction**

The United States Department of Agriculture (USDA) data provides a cost breakdown of operating expenses and projected profits, including net income before any government assistance or insurance payments are configured into the producer's overall operation. In general, for the past decade, these numbers show a loss in three major commodities/crops for South Carolinian farmers-- cotton, corn, and soybeans. However, additional factors may not be accounted for. Farmers, as businessmen, would be unable to operate with these persistent losses, which suggests there is more information to study. This paper analyzes data from the United States Department of Agriculture (USDA), Farm Related Services (FSA), and other sources to describe how these farmers are resourceful and maintain a stable income from season to season.

### **Government Involvement**

Farm Related Services (FSA) is the branch of the government that works closely with USDA. These offices span across the United States, with each attending to their local area. They assist with carrying out various government subsidy programs such as disaster relief, farm rehabilitation, disadvantaged farmer services, and crop insurance. Many of these programs are aimed at helping specific types of farmers who normally fall under one of two categories—beginning farmers or socially disadvantaged farmers. A beginning farmer is one who has not operated a farm for longer than 10 years or does not own a farm larger than 30% of the average size in their county (Beginning Farmers and Ranchers Loans, n.d.). Socially disadvantaged farmers are any persons who have been socially disadvantaged due to their gender, ethnicity, or race (Fact Sheet: Socially Disadvantaged Farmers and Ranchers Loan, 2011).

### **Producer Demographics**

## IS AGRICULTURE A SUSTAINABLE

The US Census of Agriculture (2017) indicates the typical producer is a white male with an average size farm of 441 acres. This excludes many farmers from being qualified to participate in these aid programs to get extra assistance during financially stressful months. Their exclusion is a consequence of meeting one or more of the following scenarios: a farm size greater than 30% of the average size in the county, farming longer than 10 years, or not being classified as socially disadvantaged by FSA's guidelines. Therefore, the majority of programs offered do not help the typical Southeastern American farmer.

Additionally, there are several wide spread patterns that are cause for concern in this industry. A particular concern is the rising average age of farmers. *Figure 1* is a comparison of farmers across the United States and South Carolina:

Comparison of Farmers in the United States and South Carolina

Age Categories	Number of U.S. Farmers	Number of South Carolina Farmers	Percentage of South Carolina Farmers
Under 25	50,943	499	1.3%
25-34	234,496	2,238	5.7%
35-44	390,345	4,256	11%
45-54	614,654	7,290	19%
55-64	955,345	10,693	27%
65-74	757,936	9,411	24%
75 and over	396,106	4,583	12%
Total	3,399,825	38,970	100%

*Figure 1*

## IS AGRICULTURE A SUSTAINABLE

Roughly one-third of current farmers in the United States are 65 years or older and 36% are 65 or older in South Carolina. The average age range for a farmer is 55-64. As this age increases, concern for the aging workforce is gaining traction (United States Census of Agriculture, 2017).

### **Other Trends**

As previously stated, the average farmer is a white male who works 441 acres. At current levels, the majority of household income for midsize farmers is made up almost completely by other revenue streams, (Most Farmers Receive, 2018). There is an increase in efficiency with technological advancement. However, many midsize farmers cannot afford this new technology; they are left susceptible to becoming obsolete and leaving the industry (Most Farmers Receive, 2018). Other common trends in agriculture include increased capital costs and scarcity of labor. Income in agriculture can also vary due to factors such as the futures market, commodity prices, weather, changes in each Farm Bill, and an increase in organic and produce farming.

### **Shifts in Farm Size**

Another trend that is cause for concern is farm consolidation. In recent years, there has been an observed barbell effect. Middle-size traditional farmers are financially vulnerable and under distress. A middle-sized farmer is one who has annual gross cash income before expenses of \$10,000 to \$349,999 (U.S. Department of Agriculture, Economic Research Service and National Agricultural Statistics Service, Agriculture Resource Management Survey, U.S. Census Bureau, 2018). Farms are also classified by size based on acreage. In this paper we define small,

## IS AGRICULTURE A SUSTAINABLE

medium, and large sizes by the ranges 1-179, 180-999, and 1,000+ acres, respectively.

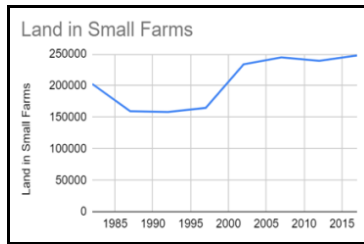

Figure 2

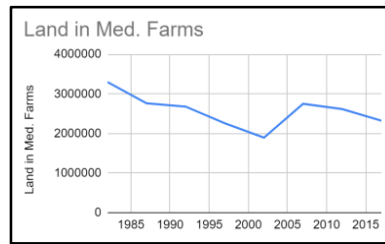

Figure 3

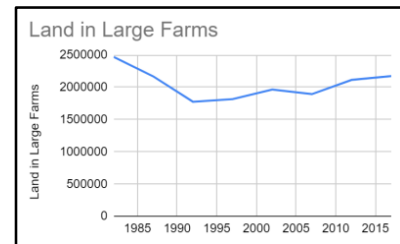

Figure 4

Figures 2-4 represent the change in land measured in acres overtime in the state of South Carolina. These values came from the previous Census of Agriculture being in 1982 to the most recent Census of Agriculture in 2017.

### Analysis

Multiple regressions were performed using the number of Mid-Sized farms and the Number of Acres in Mid-Sized Farms as the Y variables and the Number of Large Farms, Number of Small Farms, Number of Acres in Large Farms, and Number of Acres in Small Farms as the X variables. Each regression used one X variable and one Y variable. Three out of the four regressions yielded significant p-values. Two of the regressions analyzed the relationship between the number of acres in one of two farm size categories, (large and small) to the number of acres in the mid-sized farm category. For the first regression, with the number of acres in the large farm category as the X variable, returned a p-value of 0.0931, making it a significant predictor of the number of acres in mid-sized farms. The second regression, with the number of acres in small farms as the X variable, yielded a p-value of 0.1717, making it another significant predictor of the number of acres in Mid-Sized Farms. Two more regressions were performed with the number of mid-sized farms as the Y variable with the same X variables as the previous two regressions. Using the number of acres in large farms as the X variable yielded a p-value of

## IS AGRICULTURE A SUSTAINABLE

0.2312, making it a less significant predictor of the number of mid-sized operations. Using the land in small farms as the X variable, however, yielded a more significant p-value of 0.0085.

As a result of our analysis, we were able to develop two models: one for predicting the number of mid-size farms(1) and the other for predicting the land in the mid-size farm category(2). The models are listed below in equations one and two, respectively.

$$\hat{Y} = -18.9087 + 0.4939X_1 + 0.6819X_2 \quad (1)$$

$X_1 = \text{Number of Large Farms Index Value}$

$X_2 = \text{Land in Small Farms Index Number}$

$$\hat{Y} = -96.5949 + 1.8875X_1 - 0.4365X_2 + 0.5162X_3 \quad (2)$$

$X_1 = \text{Number of Large Farms Index Number}$

$X_2 = \text{Land in Large Farms Index Number}$

$X_3 = \text{Land in Small Farms Index Number}$

Using these models with the indexed values of the variables, we could determine an index number for the values of the number of mid-sized farms and land in mid-sized farms. From there we divided the index values by 100 and multiplied it by the base values to obtain the estimated results. Using the Forecast function in Excel, we forecasted the future values of the variables used in the models, then applied the forecasted variables to the models. The results can be seen in *Figures 5 and 6* on the following page.

## IS AGRICULTURE A SUSTAINABLE

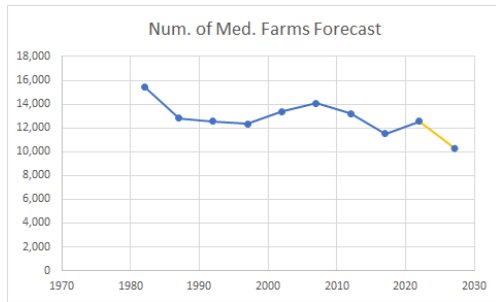

Figure 5: Number of Large Farms Forecast Graph

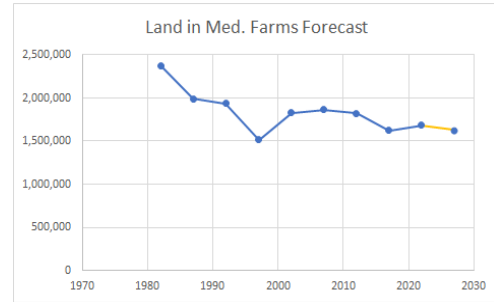

Figure 6: Land in Mid-Sized Farm Forecast Graph

The orange bar between the last two data points on *Figure 5* and *6* represent the forecasted results. Everything up to the point before the orange bar is historical data and the last two points on the graph represent the next two Censuses of Agriculture, 2022 and 2027. Results of our analysis show a relatively steep drop in the number of mid-sized farms and a much flatter decrease in the amount of land in the Mid-Sized Farm category.

### Conclusion

Farming is transitioning to a corporate, large scale industry model and traditional farms are becoming less and less common. Due to increasing capital costs, middle-size farmers are becoming financially limited. To survive all these changes producers have two options: they can move to niche markets (economies of scope), such as organic farming or farm-to-table business models, or go through growing pains and expand their operations to take advantage of economies of scale. In order to stay competitive on a large scale, producers will become more efficient or exit the industry. The producers that stay are increasing the scale of their operation through farm consolidation and investment in more efficient machines to cut down on labor costs. Some of the producers leaving the market for these big three commodities find new markets such as the organic produce market. As producers exit the market for the big three commodities and move toward other markets, prices will adjust to reach a new equilibrium.



## IS AGRICULTURE A SUSTAINABLE

## References

Beginning farmers and ranchers loans. (n.d.). Retrieved October 30, 2019, from

<https://www.fsa.usda.gov/programs-and-services/farm-loan-programs/beginning-farmers-and-ranchers-loans/index>.

Fact sheet: socially disadvantaged farmers and ranchers loan [PDF File]. (February 2011).

Retrieved from [https://www.fsa.usda.gov/Internet/FSA\\_File/sdaloans1108.pdf](https://www.fsa.usda.gov/Internet/FSA_File/sdaloans1108.pdf)

Most farmers receive off-farm income, but small-scale operators depend on it. (2018, November

30). Retrieved October 30, 2019, from <https://www.ers.usda.gov/data-products/chart-gallery/gallery/chart-detail/?chartId=58426>.

U.S. Department of Agriculture (1982-2017). Census of Agriculture. Retrieved from

[https://www.nass.usda.gov/Publications/AgCensus/2017/index.php#full\\_report](https://www.nass.usda.gov/Publications/AgCensus/2017/index.php#full_report)

U.S. Department of Agriculture, Economic Research Service and National Agricultural Statistics

Service, Agriculture Resource Management Survey, U.S. Census Bureau. (2018). Figure

1: Median household income of farm operators by source and sales class, 2017. Retrieved

from <https://www.ers.usda.gov/data-products/chart-gallery/gallery/chart-detail/?chartId=58426>

## **MAXIMIZING THE USE OF RESOURCES AT ANDERSON INTERFAITH MINISTRIES THROUGH THE OPTIMIZATION CAPABILITIES OF LINEAR PROGRAMMING**

### **ABSTRACT**

The objective of this research paper is to show the use of linear programming to optimize the fundraising operations at Anderson Interfaith Ministries (AIM) through the maximization of resources. AIM is a local food bank and non-profit that serves to meet the needs of the people in the Anderson, SC area. They have several annual events that are used to raise funds for their ministry and operations. This project seeks to use linear programming to maximize the use of their fundraising capabilities to provide the optimal mix of events that will benefit the ministry the most. In the past year, AIM was able to financially assist 422 families with \$73,947 of collected charitable donations. [1] [2]

### **BODY**

#### **JUSTIFICATION FOR PROJECT**

##### ***Inspiration for Project***

This project's main inspiration was the similar project undertaken a few years ago by a group of students at the University of South Carolina to benefit the Columbia, SC based Harvest Hope Food Bank. Their project similarly used integer programming to optimize Harvest Hope's promotional strategies. The main difference in these projects is that within their project they included food drives, which are not included in this model, and they included the constraints of volunteer hours, storage costs of food collected, and supplies cost for food drive set-up. That being said, while this project initially stemmed from that original initiative, they are markedly different both in their executions and outcome. [9]

##### ***Aspects of Fundraising in Nonprofits***

As identified by Bekkers and Wiepking in their literature review of nonprofit giving, there are 8 main reasons why people contribute to nonprofits [3]. These 8 reasons are awareness of need, solicitation, costs and benefits, altruism, reputation, psychological benefits, values, and efficacy. Each of these reasons can be provided by a fundraising event in the way that these events raise awareness for the need, they solicit money, they provide a benefit of attendance (whether that be entertainment, products gained from an auction, etc.), they promote and give a feasible outlet for altruism, they show the reputation of the nonprofit organization, they provide the psychological benefits of giving by connecting givers with the organization they are seeking to help (which gives the psychological benefit of the giver seeing their gift in action), they show the values of

the organization (helping the giver connect these values to their own), and they promote efficacy in the way that the events gain the desired result of an increased contribution to the organization for which they benefit [3]. That being said, the optimal organization of events is vital to a nonprofit's fundraising success because of the way that these events help to meet all 8 reasons for people to donate. [3]

### ***The Importance of Addressing Hunger***

Hunger and lack of education are two of the biggest issues that plague every nation. Even the most developed countries struggle to meet the most basic needs of some of their residents, an issue that even the United States of America faces. Organizations such as AIM, seek to empower and meet the needs of the people in the areas they serve [1]. One emerging way to assist such organizations in meeting these needs is through the use of supply chain principles to optimize their organizations in order to insure their sustainability [4]. An article found that addresses this very idea defines sustainability as, "as the achievement of program continuity, characterized by a well-functioning model with local governance and decreasing reliance on external funding and know-how, in line with notions of sustainability used for health programs in development settings" [5]. This article also discusses the way that supply chain techniques can be used to aid in this sustainability. In this specific study, supply chain principles of operations are applied to schools in order to aid in their humanitarian relief of school feeding. This concept fits well within the supply chain area of humanitarian logistics. The goal behind this article's research and the use of supply chain principles within this area of humanitarian logistics was to provide sustainability to the school-feeding mission. Based on this information, linear programming is a viable option for such supply chain related aid.

### ***Nonprofit Resource Allocation***

Within the realm of nonprofit resource allocation, there is a critical issue which is the distribution of a scarce resource (nonprofit funds). In Lien, Iravani, and Smilowitz 2014 article on the scarce allocation of nonprofit resources provides insight into a model developed to maximize profit and service (defined by fill rate, in this case) [7]. This article goes on to discuss the heuristic developed from said research into the optimal way to maximize both profit and service of nonprofits. The specific research and model was developed with inventory management principles in mind within the Greater Chicago Food Depository (GCFD). The GCFD is an organization which, similarly to AIM, takes in donations in order to redistribute them to other sources. In AIM's case, these other sources are the people they are donated to help, while in the case of GCFD their donations are being redistributed to other Chicago-based nonprofits to serve the people of the area. Based on these organizational similarities and differences, the concept of using inventory management and other supply chain principles to improve nonprofit operations is a valid one. Thus further illustrating the justification of this project that has been undertaken. [7]

## METHODOLOGY OF PROJECT

### *Gathering Information*

The basic methodology of this project was as follows; the project began by meeting with the food pantry manager at AIM, to understand their processes of raising food through food drives. After this meeting, it was determined that there was essentially no constraint on the number of food drives that could be held throughout the year because of the great amount of help AIM receives from local churches, grocery stores, and other volunteers to organize and contribute to these events. Based on this information, I went on to meet with the Vice President of Programs, who became my contact at AIM for the remainder of my project. He was able to collect information from their development department, who organizes their events, about the average output of their annual fundraising events and the staff hours that go into each of these events. Based on the information given, it was determined that staff hours are the main constraint since, AIM is blessed with the ability to have as many volunteer hours as needed to complete their event set-up and staffing. The information gathered is shown in the table below, which includes the output of each event as well as the necessary staff hours for the planning and executive of each event.

**Table 1**

<b>Event Name</b>	<b>Average Funds Raised</b>	<b>Staff Hours Needed (total)</b>
Heart for Helping	\$ 38,000	265
All IN Dinner and Silent Auction	\$ 94,000	496
Tailgate with Attitude	\$ 50,000	348
Women AIM High	\$ 47,000	311
<b>Total</b>	<b>\$ 229,000</b>	

Additionally, it was vital to the development of the linear programming model to know how many staff hours are available for these fundraising events. For this information, I was directed to AIM's Volunteer and Special Events Coordinator. She gave me the following information in regard to their department's employee availability and roles in planning and executing events. There is a base level of approximately 500 hours put into the planning of each event between the 4 full-time employees and 1 AmeriCorps VISTA member of their team. Of this department, 2 of them primarily work on events, thus giving the events team a capacity constraint of 3,840 staff hours that can be used to facilitate the planning and executing of fundraising events.

***Developing the Linear Programming Model***

After the necessary gathering of information, as described in the section above, it was time to develop and run the linear programming model. This model was developed through the use of the information that is explained above. The table below shows the model used, with the results from running the linear programming as well.

**Table 2**

<b>Event:</b>	<b>Heart for Helping</b>	<b>All IN Dinner and Silent Auction</b>	<b>Tailgate with Attitude</b>	<b>Women AIM High</b>	<b>Total Contribution</b>	<b>Maximum Capacity of Resource</b>
<b>Decision Variable</b>	1	5.87	1	1	-	-
<b>Contribution</b>	\$ 38,000	\$ 94,000	\$ 50,000	\$ 47,000	\$ 470,889	-
<b>Constraint:</b>						
Paid Staff Hours (total of below rows)	265	496	348	311	3840	3840
Planning Hours	223	382	276	279		
Execution Hours	42	114	72	32		

The decision variable represents the optimal number of each event that should take place. This is determined by the Microsoft Excel Data Analysis Add-On, Solver. This function takes into account the output of each event as well as the necessary input and balances these with the constraints listed. The computer runs as many iterations as necessary in order to determine how best to balance these trade-offs in order to give the best possible mix of events to maximize the contribution to AIM, in this case.

The contribution, shown in dollars, comes from the information gathered in conjunction with AIM. It is, as aforementioned, the average output of each event, as given by the development department. The contribution is used within the linear programming model because the computer seeks to maximize the total output by balancing these numbers with the constraint of each event

and the total capacity of these constraints. The total contribution, based on the optimal output given by the computer, is \$470,889 raised through the mix of 1 of each event and a rounded 3 of the All IN Dinner and Silent Auction. The rounding and these results will be further explained in the following section.

Lastly, the constraint for this model was determined to be paid staff hours based on the operational information given me by AIM. The staff hours needed for each event are shown in their respective column, with the total capacity constraint of 3,840 staff hours shown in the column entitled “Maximum Capacity of Resource”.

After all the necessary information was gathered, inputted, and correctly organized into a Microsoft Excel document, the Solver function was employed to determine the optimal output. These results will be explained in the section below. [5] [8]

### ***Linear Programming Results Explained***

The results of linear programming can be seen in Table 3 below.

<b>Event:</b>	<b>Heart for Helping</b>	<b>All IN Dinner and Silent Auction</b>	<b>Tailgate with Attitude</b>	<b>Women AIM High</b>	<b>Total Contribution</b>
<b>Optimal Number of Events</b>	1	5.87	1	1	-
<b>Contribution</b>	\$ 38,000	\$ 94,000	\$ 50,000	\$ 47,000	\$ 687,629

**Table 3**

The computer software, Solver, determined that each event should be held once a year with the exception of the All IN Dinner and Silent Auction which should be held 5.87 times a year. This result is most likely due to the fact that this event brings in a markedly higher contribution, which almost doubles that of the other events. Another factor is that the staff hour input of planning and executing the All IN Dinner and Silent Auction is a somewhat higher than that of other events, but it is still not significantly high enough to make a difference when compared to its higher output.

### ***Results in Action at AIM***

If the suggestions of the linear programming model were to be used in AIM’s fundraising efforts, the result would be an additional \$458,629 in funds raised each year. This is a significant

increase, more than doubling their current amount of funds raised each year. This number was calculated as follows.

$$\text{Linear Programming Output} - \text{Current Output} = \$687,629 - \$229,000 = \$458,629$$

Based on these numbers, if AIM was able to help 422 families last year with their \$73,947 of usable charitable donations (after operating expenses are deducted), this extra amount of funds that could potentially be raised would allow AIM to serve a far greater number in the Anderson, SC community. To be exact, AIM would be able to serve 86.12% more families with the \$458,629 extra money they would have at their disposal. These calculations are shown below.

$$\text{Operating Expenses} = \$229,000 \text{ (monetary donations, previous year)} - \$73,947 \text{ (donations used, previous year)} = \$155,053$$

$$\text{Usable Donations} = \$687,629 \text{ (estimated charitable donations)} - \$155,053 \text{ (operating expenses)} = \$532,576$$

$$\text{Average Amount Used / Person Served} = \$73,947 \text{ (donations used, previous year)} / 422 \text{ (families served, previous year)} = \$175.23 \text{ (average money used / family served)}$$

$$\text{Newly Calculated Number of People Served} = \$532,576 \text{ (estimated usable donations)} / \$175.23 \text{ (calculated average money used / family served)} = 3,039 \text{ families servable}$$

$$\text{Percent Change in Families Served} = (3,039 \text{ (new calculated families servable)} - 422 \text{ (previous year families served)}) / 3,039 \text{ (new calculated families servable)} = 0.8612 = 86.12\% \text{ increase}$$

That being said, while it would be incredible for AIM to see that increase in funding it wouldn't make sense for them to put on 5 of the same events every year. Therefore, since it isn't possible to have 5 of the exact same event, a recommendation to be given from this research would be for AIM to organize an additional dinner and auction event with a different theme at a different time of the year. That way they wouldn't encroach on their already very successful All IN Dinner and Silent Auction event, but they could gain even more support each year by implementing an additional event of this nature since it was by far the highest contributor. Through this change, the result would still be an estimated increase in funding of \$94,000 which would allow for a 55.97% increase in the number of families AIM would be able to assist in the community. These calculations are shown below.

$$\text{Linear Programming Output} - \text{Current Output} = \$323,000 - \$229,000 = \$94,000$$

Operating Expenses = \$229,000 (monetary donations, previous year) - \$73,947 (donations used, previous year) = \$155,053

Usable Donations = \$323,000 (estimated charitable donations) - \$155,053 (operating expenses) = \$167,947

Average Amount Used / Person Served = \$73,947 (donations used, previous year) / 422 (families served, previous year) = \$175.23 (average money used / family served)

Newly Calculated Number of People Served = \$167,947 (estimated usable donations) / \$175.23 (calculated average money used / family served) = 958 families servable

Percent Change in Families Served = (958 (new calculated families servable) - 422 (previous year families served) ) / 958 (new calculated families servable) = 0.5597 = 55.97% increase

After meeting with the AIM development department and presenting the results of the findings, they have decided to host an additional event in the coming year in hopes of generating more revenue as this study suggests would happen. Their events coordinator was also appreciative of the way that filling out the informational form of hours spent planning the events, found in Appendix 1, helped the staff to see how much time is spent planning each part of their events.

### **COMPLICATIONS**

The major complication that occurred during this study was in the gathering of information. As we worked with AIM, they were very helpful and worked hard to get us the information we needed to develop and run the linear programming model. That being said, issues were still faced as information was gathered. It took a few tries to explain the concept of linear programming to the team at AIM so that they would understand the information that was necessary. The solution used to solve this complication was to create a worksheet that the AIM contacts could fill out, which asked them for the specific amount of time each employee put into the planning of their events. This allowed them to understand the information necessary for the model to be complete, while also allowing them to more fully think through what is required at each stage of planning the events. This worksheet can be viewed as it is attached as Appendix 1 and 2, Appendix 1 being the original blank version and Appendix 2 being the version completed by AIM.

### **POSSIBLE AREAS FOR FUTURE STUDY**

One area for future study that would be very beneficial would be for a linear programming model and subsequent information worksheet to be collected so that nonprofits could do this for themselves. This would allow non-profits all over the world to gain a better and deeper understanding of what resources go into their events, what resources are limited, what those



limitations are, and how to best balance those constraints with the money and other positives gained from their events. As shown through the research in the beginning of the paper, organizing events that engage the community in the right way and pull off the desired result are tough, so it is best to know which events are worth the effort and which aren't. Once this model was developed, it could go through test runs with other nonprofits to see if it has the desired effect of optimizing their event operations. For this model to be successful, both an excel document outlining the inputs for the linear programming model would have to be present, along with a worksheet (similar to the one used for this project) that would help other nonprofits collect the correct necessary information in order to run their own linear programming model.

## **CONCLUSION**

This paper shows the optimization effect linear programming can have on a nonprofit, through a partnership with AIM, while also showing research that proves the need and importance of such use of supply chain management within humanitarian avenues. AIM, like most other charities, does great work for their community, but through the use of linear programming, as seen through this research, if their resources are allocated more efficiently they could do even more good. Thus, this optimization formula and information can be used to not only help AIM currently use new and accurate information to influence their processes, but it can also be used in the future for AIM to continuously improve and optimize their operations, seeking to maximize their resources. As discussed in the previous section, one area of exciting future research would be to develop a model that can be used by any nonprofit to have this same optimizing effect on their business without the need for a special consultant. A major hope of this research is that it can inspire future studies and use of supply chain management to assist all organizations, but especially those that work so hard to serve the community.

**APPENDIX 1**

<b>Heart for Helping</b>													
	Director	Person 1	Person 2	Person 3	Person 4	Person 5	Person 6	Person 7	Person 8	Person 9	Person 10	Person 11	Person 12
Planning													
Scheduling													
Setting Up													
Execution													
Project Finalization and Review													

<b>All IN Dinner and Silent Auction</b>													
		Person 1	Person 2	Person 3	Person 4	Person 5	Person 6	Person 7	Person 8	Person 9	Person 10	Person 11	Person 12
Planning													
Scheduling													
Setting Up													
Execution													
Project Finalization and Review													

<b>Tailgate with Attitude</b>													
		Person 1	Person 2	Person 3	Person 4	Person 5	Person 6	Person 7	Person 8	Person 9	Person 10	Person 11	Person 12
Planning													
Scheduling													
Setting Up													
Execution													
Project Finalization and Review													

<b>Women AIM High</b>													
		Person 1	Person 2	Person 3	Person 4	Person 5	Person 6	Person 7	Person 8	Person 9	Person 10	Person 11	Person 12
Planning													
Scheduling													
Setting Up													
Execution													
Project Finalization and Review													

APPENDIX 2

Heart for Helping													
	Director	Person 1	Person 2	Person 3	Person 4	Person 5	Person 6	Person 7	Person 8	Person 9	Person 10	Person 11	Person 12
Planning	16	20	30	25									
Scheduling	2	4	10	4									
Setting Up	4	8	8	8									
Execution	2	2	4	3									
Project Finalization and Review	2	4	4	3									

All IN Dinner and Silent Auction													
		Person 1	Person 2	Person 3	Person 4	Person 5	Person 6	Person 7	Person 8	Person 9	Person 10	Person 11	Person 12
Planning / Scheduling tasks	80	40	40	30									
Sponsors	6	6	12	8									
Scheduling													
Setting Up	12	12	16	16									
Execution	5	5	6	6									
Project Finalization and Review	4	4	2	2									

Tailgate with Attitude													
	Kristi	Susan	Sarah Ann	Gabi	Person 4	Person 5	Person 6	Person 7	Person 8	Person 9	Person 10	Person 11	Person 12
Planning	30	30	30	20									
Scheduling	6	8	10	5									
Setting Up	6	8	16	10									
Execution	4	5	5	5									
Project Finalization and Review	4	4	6	4									

Women AIM High													
		Person 1	Person 2	Person 3	Person 4	Person 5	Person 6	Person 7	Person 8	Person 9	Person 10	Person 11	Person 12
Planning	20	30	25	20									
Scheduling	4	8	10	8									
Setting Up	6	16	16	16									
Execution	4	4	6	6									
Project Finalization and Review	4	4	8	4									

Selling Packages to support all events 60

## REFERENCES

- [1] AIM (2019). <https://www.aimcharity.org/who-we-are> accessed 15 November 2019.
- [2] *Annual Report*. Anderson Interfaith Ministries. 2017-2018.  
[https://cfa022f2-4941-4cad-a4cb-1fb8a174edc4.filesusr.com/ugd/7a3bc9\\_81bc319cc76f4e1ca39de6be737a74af.pdf](https://cfa022f2-4941-4cad-a4cb-1fb8a174edc4.filesusr.com/ugd/7a3bc9_81bc319cc76f4e1ca39de6be737a74af.pdf). 4
- [3] Bekkers, R., & Wiepking, P. (2011). A Literature Review of Empirical Studies of Philanthropy: Eight Mechanisms That Drive Charitable Giving. *Nonprofit & Voluntary Sector Quarterly*, 40(5), 924–973. <https://doi.org/10.1177/0899764010380927>
- [4] Bergendahl, J. A., Sarkis, J., & Timko, M. T. (2018). Transdisciplinarity and the food energy and water nexus: Ecological modernization and supply chain sustainability perspectives. *Resources, Conservation & Recycling*, 133, 309–319.  
<https://doi.org/10.1016/j.resconrec.2018.01.001>
- [5] Kahan, G. (1982). Walking through a Columnar Approach to Linear Programming of a Business. *Interfaces*, 12(3), 32–39. <https://doi.org/10.1287/inte.12.3.32>
- [6] Kretschmer, A., Spinler, S., & Van Wassenhove, L. N. (2014). A School Feeding Supply Chain Framework: Critical Factors for Sustainable Program Design. *Production & Operations Management*, 23(6), 990–1001. <https://doi.org/10.1111/poms.12109>
- [7] Lien, R. W., Iravani, S. M. R., & Smilowitz, K. R. (2014). Sequential Resource Allocation for Nonprofit Operations. *Operations Research*, 62(2), 301–317.  
<https://doi.org/10.1287/opre.2013.1244>
- [8] Mason, A. J. (2012). OpenSolver - An Open Source Add-in to Solve Linear and Integer Programmes in Excel. *Operations Research Proceedings 2011*, 401. Retrieved from <http://search.ebscohost.com/login.aspx?direct=true&db=edb&AN=93861747&site=eds-live&scope=site>
- [9] Ahire, Sanjay & Pekgun, Pelin. (2017). Harvest Hope Food Bank Optimizes Its Promotional Strategy to Raise Donations Using Integer Programming. *Interfaces*. 48. [10.1287/inte.2018.0944](https://doi.org/10.1287/inte.2018.0944).

## **OPERATIONAL CAPABILITY TRADE-OFFS AND MARKET SURVIVAL**

Ata Karbasi, Parker College of Business, Georgia Southern University, P.O. Box 8036,  
Statesboro, GA 30460, 912-678-4589, [ata\\_karbasikheyr@georgiasouthern.edu](mailto:ata_karbasikheyr@georgiasouthern.edu)

### **ABSTRACT**

There is empirical evidence that an incumbent would respond to competitors' attacks on its market by adjusting marketing mix variables. Despite the widespread occurrence of market entry and exit, the dynamics of such phenomena are complex and still poorly understood. Several studies have identified that market-specific characteristics are critical features of firms' survival in a market. However, there are a few studies in the literature that takes the operational characteristics of the firms into account. Combining the concept of market survival with the notion of the operational capabilities of a firm, the effect of the incumbent's operational trade-off on the newcomer's survival in the context of the airline industry was empirically assessed. Particularly, I analyze how adopting an operational capability strategy would affect the incumbent survival and new entrant's exit likelihood in a market. To test the hypothesis, a unique route level data set that combines airlines' network characteristics, flight service quality, flight fare with airports, and the market level data is assembled. It is expected that there is a need to consider market-based operational capabilities when applying any market defense strategy and offer prescriptions for managers on how to protect their markets more effectively by applying appropriate operational strategies. This study provides a new insight for academics and managers regarding the impact of the incumbent's operational capability trade-offs on their market survival and the likelihood of a new entrant's exit likelihood. It makes significant contributions to the marketing and operations management literature. Moreover, the managerial implication of this paper is that well-established incumbent firms should be cautious in the implementation of their operational capability trade-offs to the market entry and exit.

## Using Clustering to Generate Bus Stops for School Students

### Abstract

The goal of this research project is to optimize the procedure of creating school bus stops and assigning students to them. In many US counties, the beginning of the academic year in public schools is associated with substantial preparatory work. One of these activities is deciding where the bus stops will be located and which students will be assigned to each bus stop. In the vast majority of counties, this labor-intensive task is done manually and therefore, often results in a sub-optimal distribution of bus stops. If too many bus stops are created with too few students assigned to them, then this will result in the scheduling of additional bus routes to pick up school students, as bus routes will take too much time. In this case, the county Office of Transportation will need to spend additional funds for more buses, hiring drivers, gas and maintenance. The focus of this research, therefore, is two-fold: (a) automate the task of creating bus stops and assigning students to them, and (b) minimize the total number of stops required, resulting in fewer bus routes. The project goals will be addressed by utilizing clustering algorithms, which will allow grouping of students who live close by each other and assigning a bus stop for them. When the clustering technique is developed, the second part of this project will be to implement this proposed algorithm in a software using a combination of Python and JavaScript.

### Introduction

The purpose of this project is to research techniques and methods to help the Gloucester County (VA) Public School system save time and money by optimizing the assignments of students to bus stops. At the beginning of each academic year, the Office of Transportation for each county in the United States is faced with the problem of where to locate bus stops and which students should be assigned to each bus stop. Usually, the Department of Transportation officials spend substantial time working with a map and a list of all the students' geographical addresses trying to determine which students must be grouped together and which location to define as each group's common bus stop. The problem is very daunting and time-consuming. Usually, high school students ride the buses first, as they start school the earliest. After the high school students are picked up and dropped off at their schools, the middle-schoolers must be picked up, and lastly, the elementary school students are picked up. This means that the grouping of students (clustering) should be done separately for high, middle, and elementary school students. The sheer number of school students in any county is another complicating factor that has a potential to make this problem extremely time-consuming. For example, in Gloucester County, there are around 4,700 students. That means that there are about 2,000 elementary students, 1,600 middle school students, and 1,100 high school students that must be clustered into appropriate groups. Finally, doing such clustering manually is not only an extremely labor-intensive process, but it may result in sub-optimal grouping of students

to be assigned to each bus stops. If students' clusters become too small (each containing only a few students), it will create a large number of bus stops. In this case total driving time between bus stops will increase, resulting in the need to schedule more bus routes to visit all stops. This, in turn, may result in the need for the county to buy more buses. At a price tag of over \$100,000 per bus, this is a highly undesirable situation. The actual price tag is higher once the driver's wages, cost of fuel, and required maintenance are taken into account. Each academic year, the population and distribution of students change. New elementary school students enter the first grade, fifth-graders transition from elementary to middle school, eighth-graders transition from middle school to high school, and twelve-graders graduate. Shifting students' geography means that the problem of grouping students together must be reevaluated each academic year again and again, resulting in recurring efforts and costs. This project purpose is to propose an algorithmic approach for the task of assigning students to bus stops, saving Gloucester County Public Schools time, efforts, and money.

### **Literature review and Project Scope**

Assigning data points that share similar characteristics into groups is called clustering. Clustering applications can be found in various disciplines. Probably the most well-known example of clustering is the Periodic Table of elements; where atoms with similar chemical properties are clustered together, forming groups (or columns) of the table. In marketing, retailers are looking to find similar transactions to see if clustering these transactions together may help them create customer "profiles" with similar buying habits to help increase the effectiveness of advertising. In this project, data points are individual students, each having a location on the map, characterized by latitude and longitude. We are looking to devise an algorithm which will group together students sharing similar latitude and longitude and level of schooling.

### **Problem Limitations**

When clustering students together, we will face several challenges and limitations. First, by law, elementary school students cannot walk more than a quarter mile to the bus stop, and this figure is a half mile for high and middle-school students. This creates a limit on how far apart the most distant points of each cluster can be. Second, when determining optimal grouping of students, we have to make sure that students do not have to cross a major road to reach a bus stop because this will risk the students' safety by possibly being hit by a car. Highway 17 (George Washington Memorial Highway) in Gloucester County is an example of a major road with intense traffic we do not want students crossing (see Figure 1 below).



Figure 1. Clustering of students should be done to avoid streets and highways with busy traffic patterns.

In practical terms, it means that our algorithm must make sure that all students clustered together live on the same side of any major road in the county. For example, in Gloucester County the major roads are identified as:

- George Washington Memorial Highway (US-17)
- Hickory Fork Road
- Main Street
- Belroi Road
- Indian Road
- Ark Road
- Enos Road
- Davenport Road
- Adner Road
- Woods Road
- Farys Mill Road
- Guinea Road

Figure 2 below illustrates the major roads, which cannot be crossed by students.



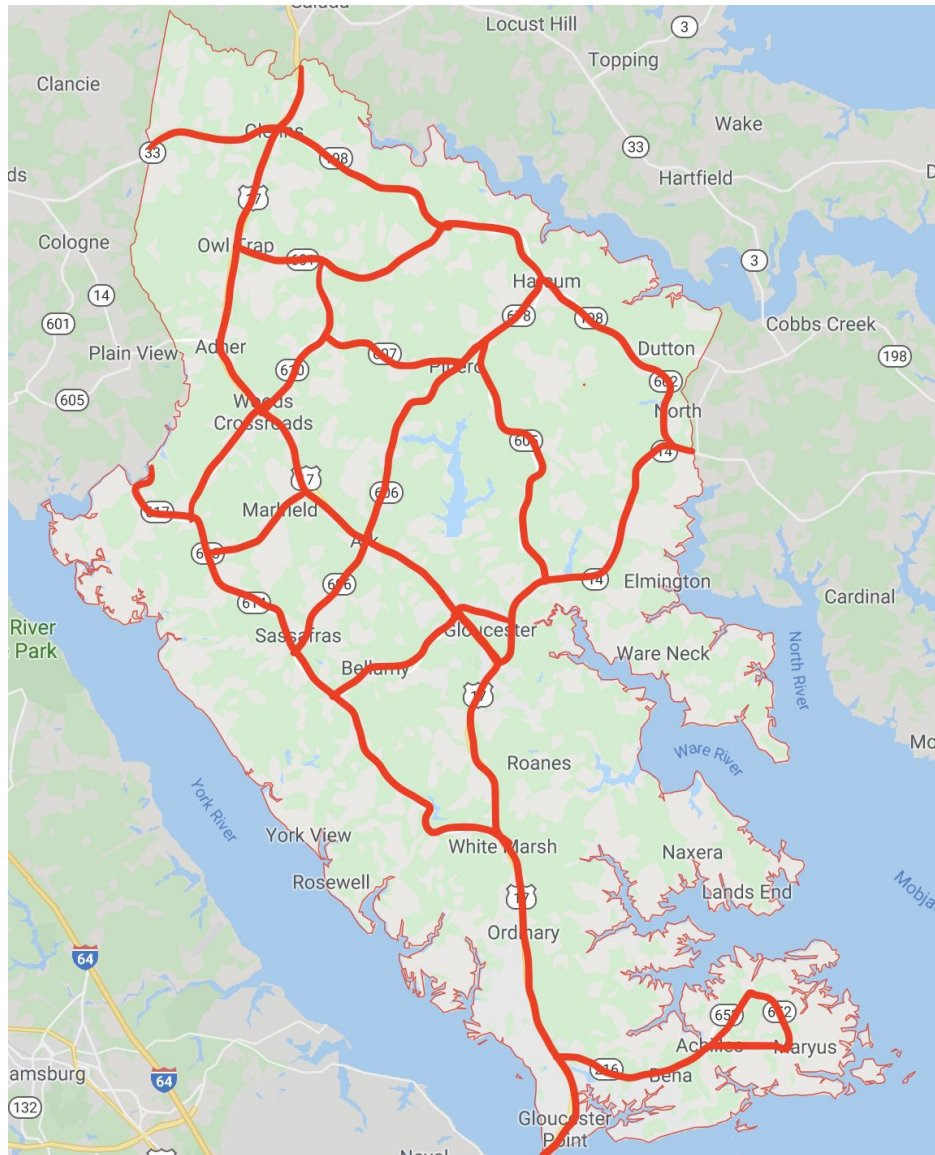

Figure 2. Map of busy streets which should not be crossed by school students in Gloucester County.

Third, in clustering students, we must be mindful of bus capacities. A maximum capacity of a school bus is 72. But, the actual carrying capacities of buses depend on what buses are operated by each county individually. In Gloucester County, for example, there are five buses with a capacity of 72, but the majority of buses can carry only 44 students. Again, in practical terms it means that our clustering algorithm should avoid creating clusters with more than 44 students. Due to safety concerns, school buses are not loaded up to full capacity. Typically, when planning routes, county officials try to load each bus with no more than 90% of the maximum bus carrying capacity.

Challenges associated with clustering are illustrated in Figure 3 below.

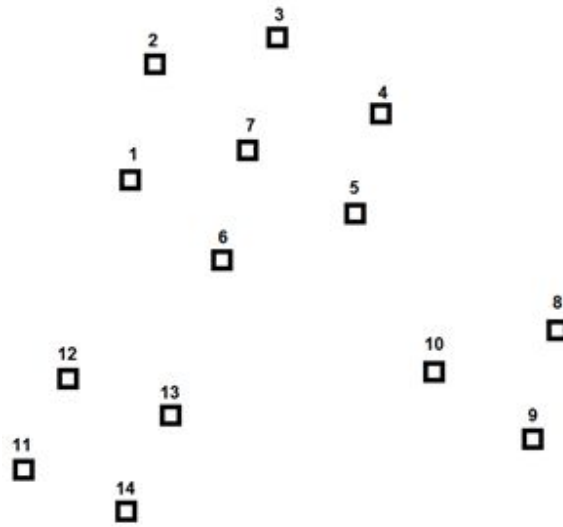

Figure 3. Fourteen students to be grouped into clusters.

It seems that in Figure 3 there are three natural clusters, as shown below in Figure 4.

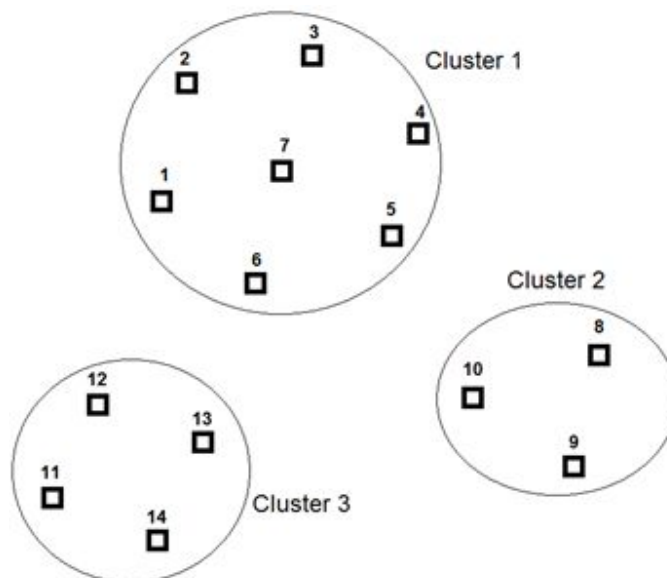

Figure 4. Obvious way to cluster the fourteen students.

But, suppose that an over-imposing the map reveals that the optimal bus stop for cluster 1 is located too far for student 3 (so that this student has to walk more than a half mile to the bus stop), and cluster 3 is intersected by George Washington Memorial Highway (US-17), one

of the major roads that need to be avoided when clustering students. The situation is illustrated in Figure 5 below.

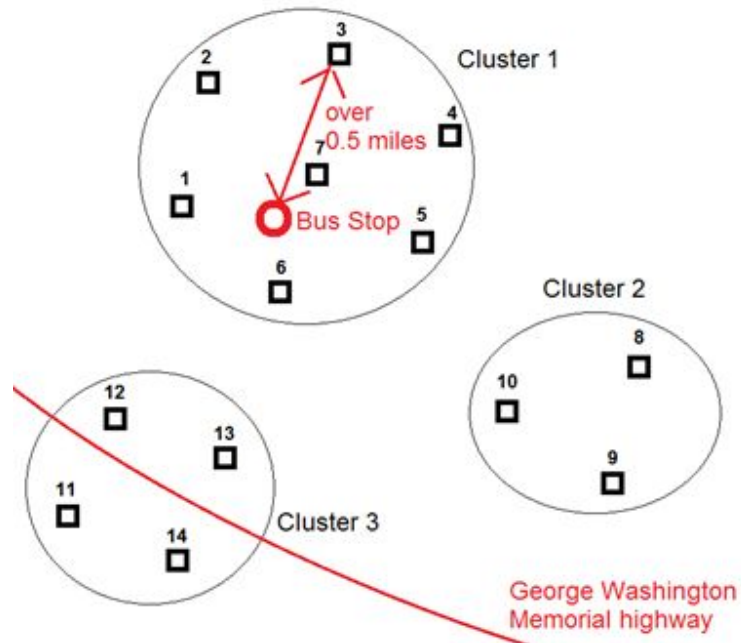

Figure 5. Challenges Arising from Geographical Specifics

In this case our algorithm must be capable of making the following feasible adjustments:

- Group students 1, 2, 6, and 7
- Group students 3, 4, and 5
- Group students 12, 13
- Group students 11, 14

The resulting clustering is demonstrated in Figure 6 below.

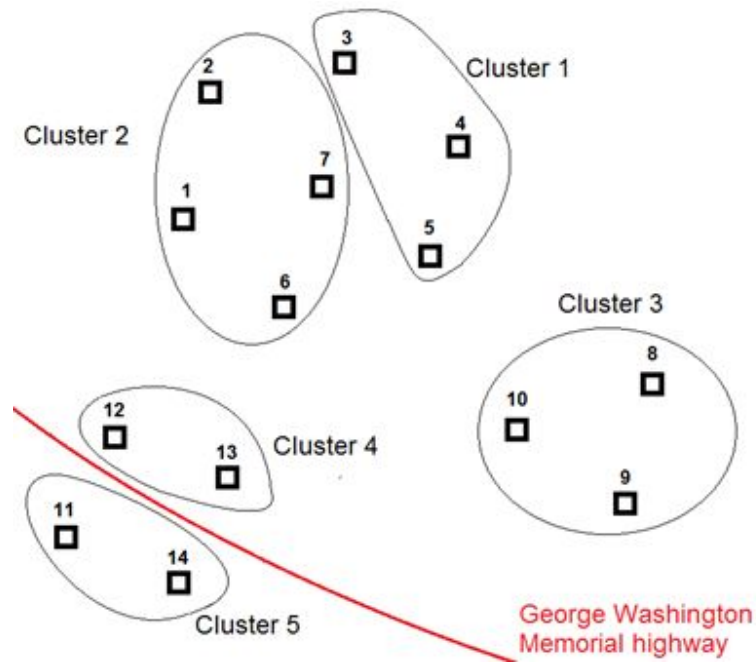

Figure 6. Feasible Clustering of Fourteen Students

### Modified k-means Clustering Approach

Among the most popular and widely used clustering techniques are hierarchical clustering and  $k$ -Mean clustering. In  $k$ -mean clustering [1], the researcher must decide at the beginning of the clustering procedure, how many clusters,  $k$ , there should be at the end of clustering. This approach is not completely feasible to use in our problem because we have no way of knowing how many clusters (bus stops) we will need to service school students population, and still conform to maximum walking distance standards. For example, suppose that the Office of Transportation decides to use 100 clusters (bus stops) for all high school students. After the algorithm finishes grouping students together into clusters, it may result in some clusters being too large in size. If this is the case, then some of the students will have to walk a long distance to a bus stop, exceeding the maximum allowable distance. This would make clustering with  $k=100$  to be infeasible. Then the Office of Transportation will have to change the desired number of clusters, hoping for the better outcome. This approach introduces a guesswork into the process of grouping students. Therefore, we could use a modified  $k$ -means clustering procedure to group students into bus stops. The procedure is described below.

The starting point of our algorithm is to identify geolocation for each student. In each county, the School Board knows geographical address for every student, but to create clusters, we need to know distances between students' houses. Therefore, prior to clustering, we must convert students' addresses into a pair of coordinates (latitude and longitude), the procedure known as geocoding. This can be accomplished, for example, by using Google Geocoding API.

The geocoding server receives a request with student's address and returns latitude and longitude for the location. After the coordinates were obtained for each student, we need to estimate the distance  $d_{ij}$  between each pair of students  $(i, j)$ . This can be done using another Google service, Google Map API, but it is very expensive. Google provides a credit of \$200 per month for 40,000 server calls, which is equivalent to \$0.005 per server call. Any server calls beyond 40,000 per month are charged at a rate of \$0.005. If we would like to cluster 500 students, for example, we would have to make  $499 \cdot 500 / 2 \sim 125,000$  server calls, resulting in a \$400 charge. A typical school district contains significantly more than 500 students, so charges for finding exact distances between them will be prohibitively high. Therefore, our proposed approach is to use an approximation for a straight line distance on a sphere, a well-known Haversine formula.

$$d = 2r \arcsin \left( \sqrt{\sin^2 \left( \frac{\phi_2 - \phi_1}{2} \right) + \cos(\phi_1) \cos(\phi_2) \sin^2 \left( \frac{\lambda_2 - \lambda_1}{2} \right)} \right)$$

In the formula above,  $(\phi_1, \lambda_1)$  and  $(\phi_2, \lambda_2)$  are the latitudes and the longitudes of points 1 and 2, respectively. The formula takes into account the curvature of the Earth when calculating the distance between two points. At the same time we realize that in most practical situations, actual path between two points is rarely direct. Harvestine formula will work well as an approximation only if two locations are on the same straight street. But more often a path between two students' houses will involve turns from one street to another. Therefore, we have adopted an analog of Manhattan distance as an approximation for the actual distance between two points (1) and (2) on a sphere, as illustrated in Figure 7 below.

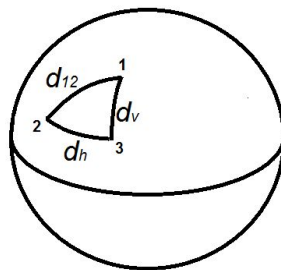

Figure 7. A Manhattan Approximation for the Distance Between Two Points.

In Figure 7, we are interested to calculate the distance between two points on a sphere. Each point is characterized by a latitude and a longitude,  $(lat_1, long_1)$  and  $(lat_2, long_2)$ , correspondingly. The curve connecting points 1 and 2 directly corresponds to an analog of a straight line on a sphere, and its length  $d_{12}$  is given by a Harvestine formula. Point 3 in Figure 5 is located on the same parallel as point 2 (and, hence, has the same latitude  $lat_2$ ), and on the same meridian as point 1 (and, hence, has the same longitude  $long_1$ ). Therefore, the trip from

point 1 to point 2 involves traveling from point 1 to point 3 along a line parallel to the meridian, with a “vertical” distance  $d_v$ , and after that, traveling from point 3 to point 2 along a line parallel to the equator, with a “horizontal” distance  $d_h$ . Note that since latitudes and longitudes are known for all three points, each of the distances  $d_v$  and  $d_h$  can be calculated using the same Harvistine formula. The “Manhattan approximation” for the distance between two points 1 and 2 is equal to  $(d_v+d_h)$ . Having performed geocoding for all school students’ home addresses provides with a longitude and latitude for each student. We can now approximate mutual distances between each pair of students using approach discussed above.

Now let's turn our attention to clustering. As we discussed above, there is no way to know the appropriate number of clusters,  $k$ , each particular geographical distribution of students will require. The simplest way to find the smallest number of clusters  $k$  is to use  $k$ -means algorithm iteratively. On each iteration, for a given  $k$ , we will group all geolocations into  $k$  clusters. For that we can use a standard Python library *sklearn.cluster*. After points were grouped, for each resulting cluster we need to check if a cluster is valid. For that purpose, we will calculate an estimated distance from each cluster’s centroid to each of the cluster's points. If any of the distances exceed the limiting distance (0.5 miles for high and middle, and 0.25 miles for elementary school students), then we label cluster as invalid. In this case we have to increase  $k$  by 1 and repeat the clustering procedure again, until all resulting clusters are valid. The pseudocode for the procedure is shown below:

Start

$k=2$

$all\_clusters\_are\_valid = False$

*while*  $all\_clusters\_are\_valid = False$ :

    cluster points using k-means procedure with current value of  $k$

$all\_clusters\_are\_valid = True$

*for* each cluster:

        if  $ClusterIsValid() == False$ :

$all\_clusters\_are\_valid = False$

$k = k + 1$

            break

End

The function *ClustersValid()* in the pseudocode checks distances from each cluster's points to its centroid. If any distances exceed maximum allowable walking distance, it returns False, otherwise it returns True. The procedure outlined above will continue until all  $k$  clusters are valid. In other words, for the while-loop to terminate, all resulting clusters must contain points which are located no further than maximum set distance from the cluster's centroid. Upon termination of the procedure, the resulting  $k$  provides a minimum number of bus stops required to pick up all students and stay compliant with regulations imposing maximum walking distance to bus stop for school students.

Note that this approach is providing only an initial point for actual allocation of students to bus stops. Using the Haversine formula to estimate a distance between two points on the map does not take into account real geography. Shown below is an example when students 1 and 2 can be grouped together, but student 3 cannot be assigned to the same bus stop. While an estimated distance between student 3 and a bus stop is less than 0.4 miles, there is no road, which will make such walk possible.

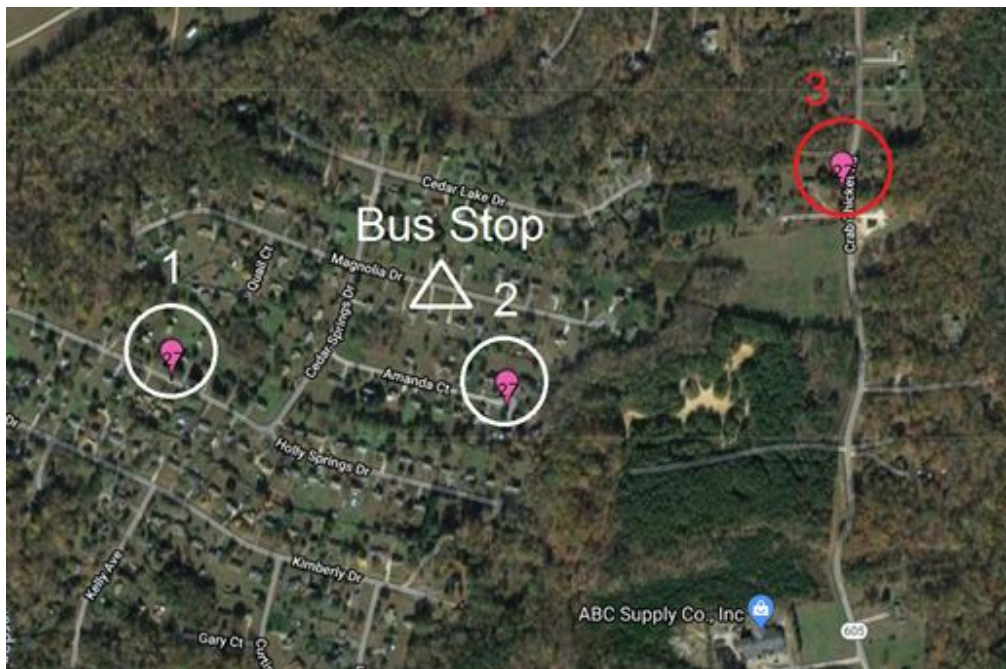

Figure 8. Estimated Distances Between Cluster Points and Cluster Centroid May Not Represent Real Walking Distances

### Implementation Results

The procedure described above has been implemented in code and tested using different number of students to be clustered. Figure 9 below shows a screenshot of the map with unclustered points, as well as the result of iterative  $k$ -means clustering.

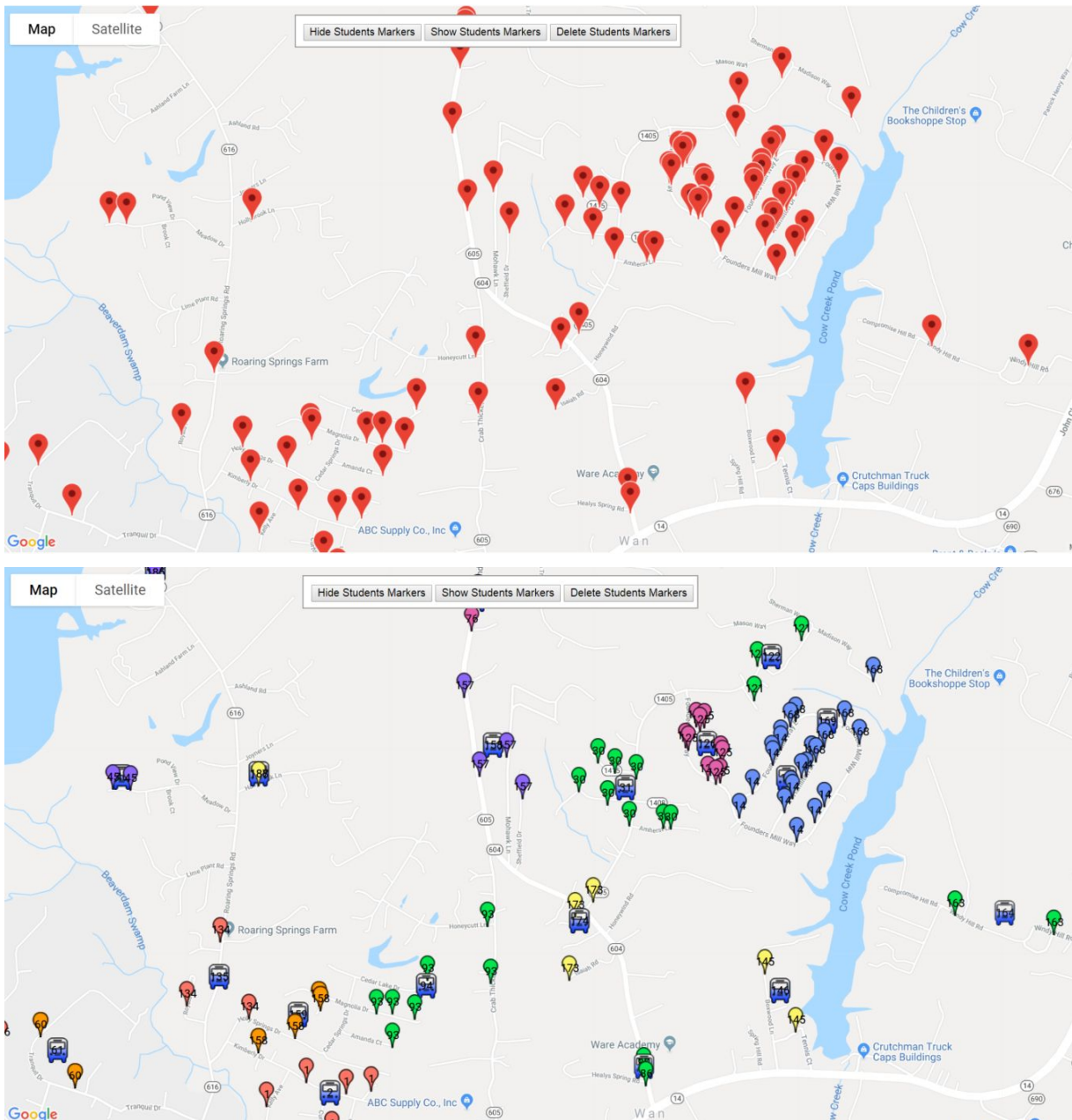

Figure 9. Unclustered points (top figure) and color-coded clusters (bottom figure), resulting from the iterative k-means algorithm.

Another widely-used clustering technique is hierarchical clustering [2]. Under hierarchical clustering, the process begins with the assumption that each student represents a “cluster of one”, and requires an individual pick up. On the first iteration, the algorithm finds the two closest students and groups them together into a cluster. On the second iteration, again, the closest students (or groups of students) are identified and merged together into a larger cluster. On each of the following iterations, clusters are merged, the number of clusters is



reduced by one and the resulting clusters are getting larger. This approach is feasible for this project, but there are two challenges which make its application problematic. The first challenge is, on each iteration, when two of the closest clusters of students are merged together, we must keep track of how long the walking distance is for each student to the cluster's center. If a cluster, resulting from a merge is too big, and students have to walk too far to the bus stop (cluster centroid), then clusters should be "unmerged". After we must proceed to the next pair of closest clusters and repeat the same procedure. The second challenge is that each iteration of the algorithm is very computationally intense. For example, on the very first iteration, we must find which two individual students live closest to each other and merge them together into a cluster of two. This requires us to know the distances from each student to each other student. If we want to cluster 100 students, to calculate the distances between all possible pairs of students will require us to perform about 5,000 calculations, and keep all results in the computer's memory. Calculations of mutual pairwise distances between 500 students will require 125,000 such calculations. Calculations of mutual pairwise distances among 2,000 students will involve 4,000,000 calculations. After the first iteration, two students who live closest to each other are grouped into one bus stop, and this group is represented by a cluster centroid. While mutual pairwise distance estimations between all other students remain unchanged, we need to calculate distances between all other students and a cluster centroid.

One can easily see that this approach will require substantial computing resources. Therefore, using a traditional hierarchical clustering for this project does not seem to be feasible.

### **Conclusions**

Using the approach outlined in this paper, we were able to implement a clustering algorithm which will allow to:

- Create clusters which are limited in size and compliant with the legal requirement on maximum allowable walking distance to bus stop
- Group students in a computationally feasible manner

### **Bibliography**

[1] E.W. Forgy (1965). "Cluster analysis of multivariate data: efficiency versus interpretability of classifications". *Biometrics*. 21 (3): 768–769.

[2] R. Dubes, A.K. Jain (1980). "Clustering Methodologies in Exploratory Data Analysis". *Advances in Computers*, Vol. 19: 113-228.

## **PERSONAL WELLNESS: AN EMPIRICAL STUDY OF THE RAMIFICATIONS OF OVERUSING INSTAGRAM**

Amber Gregory, Business Administration and Economics Department, Roanoke College, 221 College Lane, Salem, VA, 24153, [angregory@mail.roanoke.edu](mailto:angregory@mail.roanoke.edu)

Benjamin Hamilton, Business Administration and Economics Department, Roanoke College, 221 College Lane, Salem, VA, 24153, [bhamilton@mail.roanoke.edu](mailto:bhamilton@mail.roanoke.edu)

### **ABSTRACT**

Instagram is a rapidly growing social media hub. With this growth, there is a concern that using this social media giant is causing an increase in a user's depression, anxiety, the tendency of eating disorders, and a decrease in self-confidence. The growth is concerning because the more people that use Instagram, the more these mental health concerns increase. The researchers examine the problems of frequently using Instagram by surveying 116 college students at a small liberal arts institution. The data collected demonstrated that if college students use Instagram more, then they have poor personal wellness in relation to eating disorders, depression, and self-confidence. While we only test for correlation between factors, our research points to initial evidence that there is a cyclical relationship between depression and Instagram use. Mainly that the more one uses Instagram the worse they felt, which caused them to use it even more. Anxiety was insignificant in relation to Instagram use. This research sheds light on the growing problem of decreased personal wellness and its relationship to Instagram use. More research is required on this topic to investigate how depression and the tendency of eating disorders can influence Instagram use.

### **INTRODUCTION**

In the past, new technologies have always been blamed for harming young people; "radio has subliminal messaging", "TV rots your brain", and "video games will make your child a murderous sociopath". Now, Instagram has caught the attention of hysterical parents and demagogues worldwide. Instagram has been claimed to cause several mental health problems in the young people that use it. Jessica Winter, an author and editor for Slate, believes that Instagram gives a distorted view of the user posting the photo. Winter states that this perception of the "perfect life" on social media distorts the viewers' opinion of their own lives [19].

To elaborate on this theme, a 2017 New York Times article highlighted how depressed users tend to post more frequently [3]. This offers the concept that the more one uses Instagram, the more toxic it becomes. A study that put out an annual bullying survey in 2017, claims that Instagram is the number one social media outlet that leads to cyberbullying [7]. Another author, Andrea Downey also adds to this claim. Downey stated in a recent article: "It's hard not to feel worried or stressed when you're scrolling through Instagram on your couch, comparing yourself to people who seem to be living their best lives, always out and about, when you are counting your flaws having pajama day at home" [8].

Hiding behind screens and filters gives us a false sense of who we are. People may utilize filters to shape a crafted image that may not resemble reality. However, when we are

constantly using social media, we come to believe that what we are viewing is pure reality when it's not. This is dangerous for people who are susceptible to developing eating disorders or mental health challenges because it presents a false reality that they aren't good enough [1]. To further exemplify this social issue, a recent survey of 1,500 teens and young adults, states that Instagram is the worst social media network for mental health and wellbeing [11]. This leads us to the following question, "Does Instagram use cause issues with one's personal wellness?"

Next, this study will discuss the literature associated with this topic. Then, we will explore how the researchers measured the constructs of Instagram use, anxiety, depression, the tendency of eating disorders, and self-confidence through the survey questions given to college students. We will then present the findings of the survey. Then, the researchers will discuss the findings and the conclusion of the study findings.

**LITERATURE REVIEW**

The purpose of this study is to answer the question if Instagram use has an effect on Personal Wellness. Instagram use is defined by utilizing this online social media photo hub where users share images from their life with other users habitually [6]. With the previous literature on this topic, the researchers believe that Instagram use has a negative effect on personal wellness. In the following paragraphs, we define personal wellness as a function of anxiety, depression, eating disorders, and self-confidence.

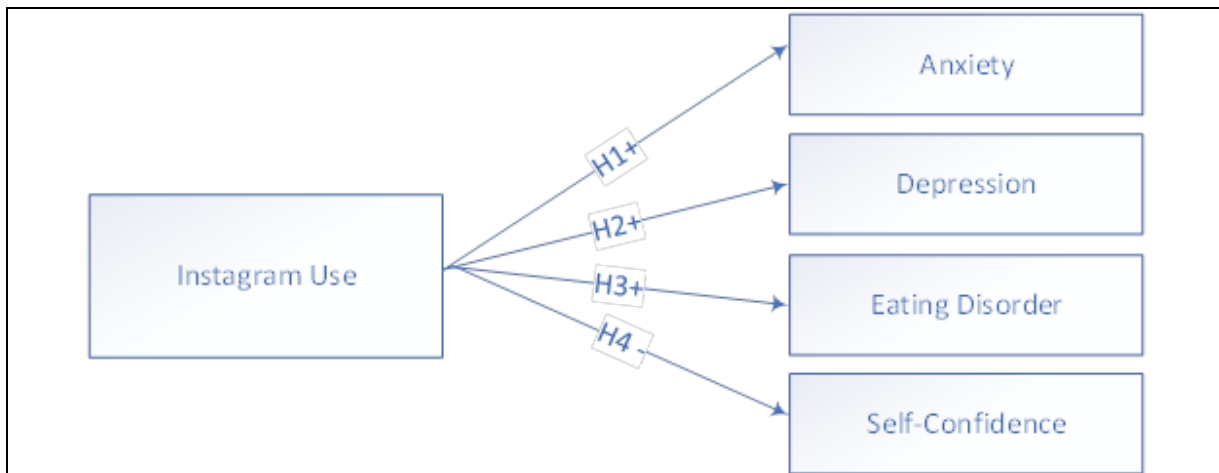

Figure 1: Research Model

Table 1: Construct Definitions		
Construct	Conceptual Definitions	Literature Cited
Instagram Use	The habitual use of Instagram over an extended time. Instagram is one of the fastest-growing online photo social web services where users share their life images	Djafarova, E., & Rushworth, C. (2017)

	with other users.	
Depression	Depression is a common, but serious mood disorder that causes severe symptoms that affect how you feel, think, and handle daily activities. To be diagnosed with depression, the symptoms must be present for at least two weeks.	“Depression”. The National Institute of Mental Health (2018)
Anxiety	A mood state characterized by worry, apprehension, and somatic symptoms. Similar to the tension caused when an individual anticipates impending danger, catastrophe, or misfortune. The threat the person is responding to may be real or imagined or internal or external.	Nugent M.S., P. (2015)
Eating disorder	Any disorder characterized primarily by a pathological disturbance of attitudes and behaviors related to food, including anorexia nervosa, bulimia nervosa, and binge-eating disorder.	PA Dictionary of Psychology. (n.p.)
Self confidence	The evaluative component of the self—the degree to which one prizes, values, approves or likes oneself.	Blascovich J & Tomaka J. (1991)

Anxiety is a mood state characterized by worry, apprehension, and somatic symptoms. Similar to the tension caused when an individual anticipates impending danger, catastrophe, or misfortune [14]. In a recent study, researchers found that people who used 7-11 social media platforms had more symptoms of depression and anxiety than those who used 0-2 forms of social media [16]. This offers evidence that the more you use social media, the more it may cause anxiety and depression.

*H1. If college students use Instagram more frequently, then it will cause an increase in anxiety.*

Depression is defined as a common but serious mood disorder that causes severe symptoms that affect how you feel, think, and handle daily activities. To be diagnosed with depression, the symptoms must be present for at least two weeks [5]. A study in 2015 looked at 117 young adults that were 18 to 29 years old and found a correlation between Instagram use and depressive symptoms. Researchers found that negative social comparisons and a greater number of strangers a user followed led to a higher tendency of depressive symptoms in participants. Comparatively, the fewer strangers that a user followed led to a lower likelihood of depression [10]. Another piece of research conducted a survey that observed 166 individuals and used 43,950 participant Instagram photos to find a relationship between Instagram use and depressive symptoms. The models created by linking users to their posts outperformed physicians at predicting depression [17]. This statement holds some weight as the researchers were able to predict if someone was having signs of depression based on the things the subjects posted.

*H2. If college students use Instagram more frequently, then it will cause an increase in depression.*

An eating disorder is any disorder characterized primarily by a pathological disturbance of attitudes and behaviors related to food, including anorexia nervosa, bulimia nervosa, and binge-eating disorder [15]. A 2017 study looked at how Instagram use was linked to increased symptoms of orthorexia nervosa, which is an obsession with eating healthy [18]. The study used an online survey that was taken by those who use Instagram and follow health food accounts. The results showed that those who use Instagram more, had a greater tendency towards orthorexia nervosa. Another study looked at the effect of posting fitspiration pictures on Instagram, which are images that are designed to motivate people to eat healthy and exercise. The study looked at 101 women who use Instagram to post fitspiration messages. They compared these women to a group of 102 Instagram users who only post travel images. The women who posted fitspiration messages scored significantly higher on drive for thinness, bulimia, drive for muscularity, and compulsive exercise [9].

*H3. If college students use Instagram more frequently, then it will increase the tendency of eating disorders.*

Self-confidence is the evaluative component of the self—the degree to which one prizes, values, approves or likes oneself [2]. A recent study of 100 Facebook users found a correlation between greater Facebook use, and increased narcissistic behavior and lower self-esteem [12]. This suggests that Facebook causes not only negative self-images, but also negative behaviors in their users. A separate study measured subject's Facebook usage per day and self-esteem. The study found that of the 150 participants, those that used Facebook more than thirty minutes a day had decreasing self-esteem the more time they spent over thirty minutes [13].

*H4. If college students use Instagram more frequently, then it will cause a decrease in the level of self-confidence.*

## METHODS

The respondents in our survey were male and female college students from a small liberal arts institution in the South East of the United States. The survey was administered using the surveying software, Qualtrics. We limited respondents to those students who used Instagram. Our survey was sent out to 664 students, and 116 of those students completed it, making the response rate 17.5%. Participants answered questions about their Instagram use, depression, anxiety, self-confidence, and eating habits, as well as a few demographic questions. See Table 2 for information on the construct measures.

Those taking the survey were asked to identify their sex. 78% of the respondents were female, 18% of the respondents were male, and 3% would rather not disclose their sex. The respondents were also asked to identify their class status. 43% of the respondents were freshmen, 20% were sophomore, 18% were juniors, and 18% were seniors. See table 3 for more information on the demographic questions.

Instagram use was measured by using questions that the researchers created. There were ten different items that the respondents had to answer. The first item asked if the respondent used Instagram. If they selected yes, then they could complete the survey. If they responded no, then they were sent to the end of the survey. Other items include questions such as, "I care about the amount of likes that I get on each picture that I post on Instagram" or "I often compare the way I look to those who appear on my Instagram feed." For Instagram use, the Cronbach's Alpha score was a .768, which is considered excellent, by Comrey and Lee [4].

To measure the self confidence level of the respondents, the researchers adapted the Rosenberg Self-Esteem scale. There were ten items that the respondents answered to using a Likert scale of strongly disagree to strongly agree. The items included; "Overall, I am satisfied with myself.", "I feel that I have a good number of qualities." and, "I take a positive attitude towards myself." The Cronbach's Alpha score was .665, which is considered very good.

When measuring depression, the researchers adapted the Beck's Depression Inventory. There were twelve items that the respondents had to indicate how strongly they disagreed or agreed if they had felt or behaved that way in the past month. A few of the items were: "I often feel sad.", "I've had suicidal thoughts.", "I feel like I am worthless" and "I blame myself for everything bad that happens." For depression, the Cronbach's Alpha score was a .931, which is considered excellent.

The tendency to have an eating disorder was measured by modifying the Eating Disorder Examination Questionnaire (EDE-Q 6.0). There were nine items that the respondents were to select how often they felt or behaved during the past month using a scale of never to all the time. Some of the items included: "Have you ever been deliberately trying to limit the amount of food you eat to influence your shape or weight?", "Have you gone long periods of time (8 waking hours or more) without eating anything at all to shape or influence your weight?" and "Have you ever had a definite fear that you might gain weight?" The Cronbach's Alpha score for eating disorders was .931, which is considered excellent.

The Zung Self-Rating Anxiety Scale was adapted to measure anxiety. There were ten items that the respondents had to indicate how often they had felt this way or behaved this way during the past month. They indicated this by using a scale that ranged from none of the time to all of the time. Some of the items included: "I feel more nervous or anxious than usual.", "I get upset easily or feel panicky." and "I can breathe in and out easily." The Cronbach's Alpha score was .685, which is considered good.

Table 2: Construct Measures

Construct	Cronbach's Alpha	Number of items	Mean	Standard Deviation
Self confidence	0.665	10	3.085	0.5445
Depression	0.931	12	2.663	0.9561

Anxiety	0.685	10	3.559	0.5663
Eating Disorders	0.931	9	2.589	1.0834
Instagram Use	0.814	7	2.891	0.8956

## RESULTS

We tested our model using regression analysis. First, we examined a correlation matrix to confirm the relationship between all constructs. Table 5 shows the correlations between constructs. All correlations were significant except the relationship except those relating anxiety and to eating disorders or Instagram use.

Construct	Self-Confidence	Depression	Anxiety	Eating Disorders
Depression	-0.824*			
Anxiety	0.470*	-0.459*		
Eating Disorders	-0.618*	0.591*	-0.168	
Instagram Use	-0.279*	0.292*	-0.106	0.487*
*p-value <.001				

Second, we ran a series of linear regression using each dimension of personal wellness as a separate dependent variable and Instagram usage as an independent variable.

Our results of the linear regressions showed that depression and eating disorders were positively affected by Instagram use, thus confirming hypothesis H2 and H3 (H2: B: 0.311; t-statistic: 2.892; p-value: <.001; H3: B: 0.574; t-statistic: 5.140; p-value: <.001), whereas Instagram use negatively affected one's self-confidence (H4: B: -0.169; t-statistic: 2.859; p-value: <.001).

Anxiety was not significantly related to Instagram use, disproving hypothesis H1 (H1: B: -0.067; t-statistic: -1.025; p-value: not significant).

## DISCUSSION

The researchers found some evidence to support the central hypothesis that if college students use Instagram more frequently, then it will cause a decrease in personal wellness. Specifically, the researchers found that Instagram use causes depression and tendencies of eating disorders. Our sub-hypotheses states, if college students use Instagram more frequently, then it will cause an increase in depression, anxiety, the tendency of eating disorders, and a decrease in the level of self-confidence.

The data did indicate that decreased personal wellness is positively correlated with more Instagram use. Since personal wellness is difficult to measure, an additional model tested whether personal wellness also affected Instagram use and some of these were found to be true. The more depressed someone is and the more they exhibit eating disorders, the more frequently they will use Instagram. Essentially, both depression and the tendency of eating disorders predicted a higher use of Instagram. This supports that there may be a cyclical relationship of both depression and eating disorders. Thus, people who are more depressed or have a higher tendency of eating disorders tend to use Instagram more. Anxiety was not significantly correlated to Instagram use.

Many of the participants reported that they initially joined Instagram to keep up with people that they had a relationship with. In the survey, one of the open-ended questions states, "Why do you use Instagram? Is this why you first started using it? Explain." A number of responses followed the theme of using it to keep up with people. "My friends used [Instagram], and then I joined as well. Why? Do not really know. Maybe to have something to do while you wait for something. Also, it keeps you updated about your friends and favorite celebrities/artists." Another quote states, "[I use Instagram] to stay updated on what everyone is doing with their lives. At first it was just because everyone else had it." One interesting response stated that "[I use Instagram] to post pictures and get likes. It's like a confidence boost. And maybe I can't remember why I first started using it [-] it was something a lot of people were getting and enjoying so I thought I'd try it."

This indicates that there may be an element of using Instagram to relieve depressed symptoms. The next open-ended question states, "Do you think there are aspects of Instagram that are beneficial? If so, please explain." The following quotes exemplify the main theme that Instagram is beneficial to keep in touch/ keep up with others. "[I use Instagram to] keep in touch with others, similar to all social media." Another participant states, "Yes, you can [use Instagram to] see what other people in your life are doing." There were a few notable outliers of people who said that Instagram was not at all beneficial, but these quotes exemplify the main response.

The most striking open-ended question responses followed a theme of poor emotional responses when using Instagram. The question states, "Tell us a time when social media gave you strong emotions. What emotion did you feel and what (generally) happened to cause that emotion?" The main theme is that people generally felt sad when they saw images that caused them to compare themselves to others. One subject states, "[I felt a strong emotion] when I saw my ex with another girl," and another states, "[when I] feel like I'm not skinny enough. I feel that my body image is not great because of the girls I see on Instagram." Additional quotes state, "[When I] compare myself to others, it caused me to be self-conscious and it lowered my self-esteem" and "[When I] see my friends go out and have fun without me and proceed to post pictures from the event always makes me feel excluded and lesser." Quotes like these were the overwhelming response. However, there were a few outliers such as; "It usually does not give me strong emotions. I don't spend a lot of time on social media, but the only time I can think of when it gave me strong emotions is when they were positive because I was excited for a friend for an event." This indicates that when people do not spend as much time on social media, it can be used more for positive purposes.



If a person is suffering from depression or eating disorders, they are more likely to use Instagram to feel better, possibly making them more vulnerable to images that compound their depression.

The next question states, "Do you think there is more pressure now to look and/or feel a certain way? Explain your answer." The main theme is that yes, social media has increased the pressure to look "perfect". The following quotes exemplify this theme. A subject stated, "I believe a vast majority of Instagram posts are ego-stroking in order to satisfy the societal norms as the individual sees it. Others might not understand this sad subculture of fakeness that comes from Instagram and in turn buys into the idea that they should be shameful or offended by their own actions." This response indicates that society may be part of the problem with Instagram culture. Another quote states, "People on social media try to show off the best parts of themselves, so you think that they always look like that and wonder why you don't look like they do." This highlights how Instagram is a way for people to display the good parts of their lives as discussed by authors in the introduction. The next quotes further represent this theme, "Yes, the media tells us that skinny is better" and "Especially if a person follows celebrities or models etc. The pictures of a perfect body are easily accessed and because they are viewed so often, it can make one want to change their appearance even more to maybe feel accepted or beautiful." It should be noted that the participants in the open-ended questions attributed Instagram to less confidence, however self-confidence was not significantly correlated to Instagram use in the data.

The data collected demonstrates that the more depressed a person is, the more likely they were to use Instagram. In the open-ended response, the rhetoric theme of many of the responses exemplified this. Many of the subjects appeared sad or angry in their feelings towards Instagram. This may offer evidence that people use Instagram because they want to "show off their lives" to others and only reveal the exciting/good parts of their lives. The fact that anxiety was not significant is surprising because anxiety and depression often go hand in hand. Self-confidence was also not significant which is surprising as well, since depression is the inverse of self-confidence. It's also interesting that the person's perception that they are in control of their personal wellness (health locus of control), was also insignificant in the data.

More research is required on how depression and eating disorders affect Instagram use due to the small sample size and how age specific to college students the survey was. In addition, mostly freshmen took the survey, so it was very age and sex oriented to college freshmen females. More women took the survey, so a more diverse population to study a higher number of males is required.

## **CONCLUSION**

This research offers evidence to reveal how Instagram use affects personal wellness. The overall hypotheses stated that Instagram use causes a decrease in personal wellness. This hypothesis was proven to some extent. The research found that when college students exhibit decrease in personal wellness in relation to eating disorders, depression, and self-confidence, the more they use Instagram. However, this research found that Instagram use

was insignificant in regard to anxiety. The researchers had a credible sample size of 116 students; however, a larger sample size would have improved the reliability of the results. The researchers were surprised that Instagram use was not correlated to a person's level of anxiety. From the data selection questions, and the open-ended response questions asked, the researchers concluded that most of the participants disliked Instagram because it affected their self-worth. Further research is required to explore more diverse samples such as a different age group, and the gender of the participants. Further research should also be done to see if the lack of male respondents skewed the data. The researchers believe this study sheds light on how growing social media use can be incredibly damaging to one's mental state and recommends that Instagram, like all things, be used in moderation.

## REFERENCES

- [1] Anonymous. How Instagram Can Encourage Eating Disorder Behaviors. (2018, May 04). Retrieved November 18, 2018, from <https://www.eatingdisorderhope.com/blog/Instagram-encourage-eating-disorder>
- [2] Blascovich J, Tomaka J. (1991) Measures of self-esteem. In: Robinson JP, editor; , Shaver PR, editor. , eds. Measures of personality and social psychological attitudes. San Diego, CA: Academic Press, pp. 115–155
- [3] Chokshi, N. (2017, August 10). Your Instagram Posts May Hold Clues to Your Mental Health. Retrieved November 14, 2018, from <https://www.nytimes.com/2017/08/10/science/Instagram-mental-health-depression.html>
- [4] Comrey, A.L., and Lee, H.B. (1992) A First Course in Factor Analysis, Erlbaum, Hillsdale, NJ. Retrieved December 3, 2018.
- [5] "Depression". The National Institute of Mental Health (2018). Retrieved 11/13/18 <https://www.nimh.nih.gov/health/topics/depression/index.shtml>
- [6] Djafarova, E., & Rushworth, C. (2017). Exploring the credibility of online celebrities Instagram profiles in influencing the purchase decisions of young female users. *Computers in Human Behavior*, 68, 1. doi:10.1016/j.chb.2016.11.009
- [7] Djudjic, D. (2017, July 24). Instagram ruins self-confidence and mental health in teenagers, study finds. Retrieved November 18, 2018, from <https://www.diyphotography.net/Instagram-ruins-self-confidence-mental-health-teenagers-study-finds/>
- [8] Downey, A. (2018, May 14). Are you plagued by Instagram anxiety? These are the signs to watch out for... Retrieved November 18, 2018, from <https://www.thesun.co.uk/fabulous/6282129/Instagram-anxiety-social-media-stress-signs-symptoms/>
- [9] Holland, G., & Tiggemann, M. (2017). "Strong beats skinny every time": Disordered eating and compulsive exercise in women who post fitspiration on Instagram. *The International Journal of Eating Disorders*, 50(1), 76-79.
- [10] Lup, Katerina. Trub, Leora. Rosenthal, Lisa. (May 2015). Instagram #Instasad?: Exploring Associations Among Instagram Use, Depressive Symptoms, Negative Social Comparison, and Strangers Followed. *CyberPsychology, Behavior & Social Networking*

- [11] MacMillan, A. (2017, May 25). Why Instagram Is the Worst Social Media for Mental Health. Retrieved November 18, 2018, from <http://time.com/4793331/Instagram-social-media-mental-health/>
- [12] Mehdizadeh S. Self-presentation 2.0: narcissism and self-esteem on Facebook. *Cyberpsychology, Behavior & Social Networking* 2010; 13:357–364
- [13] Muqaddas J. et al. (2017). Impact of Social Media on Self-Esteem. *European Scientific Journal*. Vol.13, No.23 ISSN: 1857 – 7881
- [14] Nugent M.S., P. (2015, June 23). Definition of ANXIETY (Psychology Dictionary). Retrieved November 12, 2018
- [15] PA Dictionary of Psychology. (n.d.). Retrieved November 13, 2018, from <https://dictionary.apa.org/eating-disorder>
- [16] Primack, B. A., Shensa, A., Escobar-Viera, C. G., Barrett, E. L., Sidani, J. E., Colditz, J.B., & James, A. E. (2017). Use of multiple social media platforms and symptoms of depression and anxiety: A nationally-representative study among U.S. young adults. *Computers in Human Behavior*, 69, 1-9. doi:10.1016/j.chb.2016.11.013.
- [17] Reece, A. & Danforth, C., (2017). Instagram photos reveal predictive markers of depression. *EPJ Data Science*. Retrieved November 18, 2018
- [18] Turner, P., & Lefevre, G. (2017). Instagram use is linked to increased symptoms of orthorexia nervosa. *Eating and Weight Disorders - Studies on Anorexia, Bulimia and Obesity*, 22(2), 277-284.
- [19] Winter, J. (2013, July 23). Here's Why Instagram Is Even More Depressing than Facebook. Retrieved November 14, 2018, from [http://www.slate.com/articles/technology/technology/2013/07/Instagram\\_and\\_self\\_esteem\\_why\\_the\\_photo\\_sharing\\_network\\_is\\_even\\_more\\_depressing.html](http://www.slate.com/articles/technology/technology/2013/07/Instagram_and_self_esteem_why_the_photo_sharing_network_is_even_more_depressing.html)

## **RESOURCE ORCHESTRATION: COSTS AND RISK IMPLICATIONS**

Melanie Hinterplattner

Georgia Southern University; University of Applied Sciences Upper Austria – Logistikum

PO Box 8036, Statesboro, Georgia 30460-8036

+1 (912) 541-0045

[mh11813@georgiasouthern.edu](mailto:mh11813@georgiasouthern.edu)

### **Abstract**

Although a growing amount of literature highlights the importance of effective resource orchestration, little is known about the costs associated with adjusting the firm's resource base and its risk implications. Resource adjustments are necessary to stay competitive and, in best case, increase the firm's market value. They are, however, not costless and can expose firms to risk. It is therefore critical to understand what resource adjustments (expressed in adjustment costs) bear what risk. In this paper, we examine the relationship between resource adjustment costs and a firm's downside risk, i.e. the risk of below target performance. Analyzing a large secondary data sample of 7,439 US firms, we seek to find support for our hypothesis that there exists an inverse U-shaped relationship between adjustment costs and downside risk, with the highest risk occurring at a medium level of adjustment costs.

## **VALUE OF ACCREDITATION FOR COMPUTING PROGRAMS VS. ENGINEERING PROGRAMS**

Caitlin McOsker, College of Engineering and Computing, Georgia Southern University,  
C.O.B.A. Dr, Statesboro, GA 30458, 762-231-9621, clang@caitlinlang.org,  
cm11625@georgiasouthern.edu

### **ABSTRACT**

This paper looks to investigate the value of ABET accreditation for students of computing programs as compared to engineering programs. This is done by comparing the number of job ads that indicate a preference or requirement for ABET accreditation for the two categories. Job ads are scraped from popular job posting website Monster.com using relevant search terms, then analyzed using a t-test to determine if there is a difference between the two groups.

### **LITERATURE REVIEW**

The first part of this review gives a brief overview of the ABET organization and outlines the accreditation process. This is to understand the process programs go through to achieve ABET accreditation, as well as some historical background. Then, we explore the costs and perceived return on investment for the students in ABET accredited programs.

#### **About Accreditation and ABET**

Academic accreditation as provided by private organizations is one of the cornerstones of American higher education [5]. Going to not only an accredited institution, but attending a separately accredited program, is an important requirement for some students. Accreditation reflects the accountability of a program, providing them with a sense of assurance that their degree will be worthwhile after graduation [11]. This is often emphasized in STEM career paths that begin at the university level.

ABET, Inc., formerly the Accreditation Board for Engineering and Technology, is a non-profit, non-governmental organization founded in 1932 that acts as the United States main accreditation body for STEM programs, particularly in the engineering and computing disciplines. According to their website ABET.org, ABET accreditation seeks to assure that post-secondary programs that receive ABET accreditation meet “quality standards of the profession for which that program prepares graduates.” These “standards” are implemented with the help of ABET affiliated member societies, and since ABET covers such a wide range of disciplines, these requirements vary between sectors and have separate committees [1].

Since the 1990’s, ABET has had a hand in accrediting computing programs in the United States, as well as internationally. In 2001, ABET merged with CSAB, the Computing Sciences Accreditation Board, and formed their Computing Accreditation Commission [9]. The CAC generates and approves criteria for the four programs they cover: computer science, cybersecurity, information technology, and information systems.

The road to program accreditation is an involved 18 month process every few years. Aside from the time commitment, there is a monetary value to each step of this process [1] [5]. While many institutions see accreditation as a necessary part of higher education, it is not well understood how important accreditation in general is for programs like computer science and information technology. Constantly changing industry standards, resource cost, and changing program goals have muddied the waters on whether ABET accreditation is worthwhile for this particular field [8]. Programs make this investment with the hope that accreditation will offer a return on investment for its students, but there are serious financial and time commitments from faculty and staff to stay accredited.

### **Investigating Accreditation and Its Value**

Because students of computing do not have the same level of licensure requirements as engineering [11], this raises several questions. Is accreditation important for computing disciplines; specifically, within the programs covered by the CAC, how important is accreditation for information technology students? Where is the intersection between the goals of ABET and the programs seeking accreditation, and is this intersection great enough to warrant the time and costs? Is there an industry requirement for information technology graduates to have attended an accredited university, or has this become an expensive self-imposed check-mark for IT programs?

There are a variety of reasons that programs seek accreditation [5]. In a paper from 2018 titled “The Value of ABET Accreditation to Computing Programs,” the authors say that accreditation “projects both the image and reality of a commitment to continuous improvement, a commitment to adequate resources, and a commitment to deliver a curriculum that includes foundational and advanced topics...” [11]. This statement is supported by the general criteria laid out in the “Criteria for Accrediting Computing Programs” published by ABET in 2018, which include requirements to regularly evaluate if criteria are being reached, and to apply that information towards “continuous improvement of the program.” The 2019-2020 standards also require that facilities are adequate for student use and that the curriculum “prepare[s] students for a career, further study, and lifelong professional development in the computing discipline associated with the program” [2]. According to Fisher, some departments might have internal pressure from the college or university to seek out accreditation. For less established programs, they may see accreditation as necessary to be able to compete.

While the reasons for choosing to seek accreditation can be many, it is hard to determine if having or not having gone to an accredited university has direct effects on graduate’s job prospects. In his paper, Oudshoorn says that accreditation for computing is important because it has set the benchmark in other areas; in fact, he says that “accreditation criteria for engineering is recognized as so valuable that... applicant’s resumes will not even be considered if their degree is from a non-accredited institution.” This suggests that, because the CAC sets criteria of similar “structure and content” as the EAC (Engineering Accreditation Commission), the same value should be placed on accreditation in computing. However, they do not address whether this same pressure can be found in the computing disciplines within the United States [11].

Similarly, in Fisher's study of a 38-member industrial advisory board (IAB) supports this idea. 40% of California employers said accreditation affects the offered salary of job applicants. However, his survey also concluded that employers are "mixed on the question of there being a difference between employees with or without an accredited degree" [7].

Overall, while there are a variety of reasons why programs seek accreditation, it is unclear whether having that status is necessary within industry, or whether lack of ABET accreditation directly affects computing graduate's job prospects.

### **Mining Job Ads**

In the age of information, there has become a growing need to acquire data sets from the greatest collection of information: the Worldwide Web. This has caused a rise of web scraping to acquire and store data to analyze for many reasons, from analyzing current business environments to studying economic trends. Web scraping techniques follow the same structure: the input is the HTML of a website, and the output is structured data (i.e. CSV files, spreadsheets, database tables) [13]. One popular method for automating web scraping is through extraction and parsing using Python scripts. Four Python libraries commonly used for extraction and cleaning are BeautifulSoup, requests, pandas and nltk, although there are others.

Within the realm of text scraping, the nature of online job ads makes them an opportune source of data [10] [13]. It is consistent in supplying the following information:

- Company
- Job title
- Expected skills
- Location [13].

The organization of online job search engines is also convenient for text scraping, as the jobs are presented in a list that can be easily extracted. Because of these factors, using online job ads from job search websites has been used to study the relevance, desired skills, and types of jobs currently on the market [4] [12].

There are some biases within job ad data that must be considered, however. Job ads do not represent every job, and they are not accurately represented for every sector [4]. STEM and college graduate jobs are generally overrepresented, while blue-collar work is often under. This is because these employers target the demographics that are more likely to seek out jobs online.

However, for jobs within STEM, this can lead to an abundance of information about what skills are currently in demand. In a 2018 study about the demand for ICT and statistician employment, text scraping was used to acquire 1,007 job ads based on certain criteria relevant to their study [10]. A similar text scraping method was used to analyze information technology employers in Northern Russia, in which Python was used to gather the data [12].

## **METHODOLOGY**

First, we will present the hypothesis and the reasoning behind it. Then, outline the steps taken to acquire the data and clean it. Finally, we will describe how we analyzed the data.



## Hypothesis

The hypothesis is that more job ads targeting engineers require ABET accreditation than job ads for computing disciplines. This hypothesis is based on previous studies [7] [8] [11]. To test this hypothesis, we conducted a hypothesis test based on the sample proportions of job ads from Monster.com containing specific keywords.

## Data Acquisition

A Python script was written to scrape job ads from Monster.com, which utilized the BeautifulSoup, requests, and pandas libraries. The script found the job description data and the relevant information about each job listing, such as company, location, position name, the url for the posting, and the name of the search. Then it looped through all the URLs in the URL list. Within each page's 'soup,' we used the find\_all(), find(), and compile() BeautifulSoup methods to find all of the links to job postings in the page. Then it looped through this list of record URLs. In this for loop, if statements were used to remove ads, copies, and job ads with the same company and job title across different locations. Then, the descriptions were tokenized and cleaned.

Initially, we ran this script using job descriptions from the Bureau of Labor Statistics' for "computer and information technology positions" [6]. The occupations searched were

- Computer Network Architect,
- Computer Programmer,
- Computer Support Specialist,
- Computer Systems Analyst,
- Database Administrator,
- Information Security Analyst,
- Network and Computer Systems Administrator,
- Software Developer, and
- Web Developer.

The second set of data was based on the Bureau of Labor Statistics's job descriptions for

- Civil Engineer,
- Computer Hardware Engineer,
- Electrical and Electronics Engineer,
- Industrial Engineer, and
- Mechanical Engineer [3].

## Data Analysis

Next was to analyze the job ads for related terms. The script looped through and checked the descriptions for three terms: ABET, accreditation, and accredited. These counts were then recorded as 1 or 0. Then a hypothesis test was conducted to compare the proportion of ads from each category that mentioned our keywords. We assume that

$$H_0: p_c - p_e = 0, \alpha = 0.05 \quad [1]$$

where  $p_c$  is the population of computing ads,  $p_e$  is the population of engineering ads, and  $\alpha$  is the statistical significance, meaning that the populations of job ads with keywords is the same for both computing and engineering. The alternative hypothesis is stated as

$$H_a: |p_c - p_e| > 0, \quad [2]$$

indicating that the populations are not the same, and if  $p_c - p_e < 0$ , then our keywords are more prevalent in engineering job ads.

To test this, a t-test of the proportions of the samples was done, using  $n_c$  as the sample of computing ads and  $n_e$  as the sample of engineering ads. The following equation was used to calculate the z-score of the proportions:

$$z = \frac{(\hat{p}_c - \hat{p}_e) - 0}{SE}, \quad [3]$$

where the standard deviation is

$$SE = \sqrt{\hat{p}(1 - \hat{p})\left(\frac{1}{n_1} + \frac{1}{n_2}\right)} \quad [4]$$

and the sample proportion is

$$\hat{p} = \frac{s_c + s_e}{n_c + n_e}. \quad [5]$$

Finally, the  $p$ -values of the three tests were evaluated, with a statistical significance of  $\alpha = 0.05$ .

## RESULTS

Below are the results of the data scraping methods outlined above:

*Table 1: Keyword counts*

Keywords	Computing	Engineering
“abet”	$s_1 = 4$	$s_2 = 110$
“accredited”	$s_1 = 365$	$s_2 = 715$
“accreditation”	$s_1 = 212$	$s_2 = 57$
<b>Number of Ads Analyzed</b>	$n_c = 7652$	$n_e = 4682$

Table 2 outlines the results of the t-test calculations for each keyword.

*Table 2: Z-score calculations*

Keywords	$\hat{p}_c = \frac{s_c}{n_c}$	$\hat{p}_e = \frac{s_e}{n_e}$	$\hat{p}$	SE	z	p-value
abet	0.00052	0.02349	0.00924	0.00178	-12.9377	0
accredited	0.0477	0.15271	0.08756	0.00524	-20.0231	0
accreditation	0.02771	0.01217	0.02181	0.00271	5.73075	4.99928E-09

Therefore, we reject the null hypothesis because the *p-values*, the probability that the observed results are accurate, for all three search terms is less than the stated statistical significance of 0.05.

## DISCUSSION

This test compared how employers value ABET accreditation for two different fields, computing and engineering. The purpose was to look for differences in value for students in these different fields, with the assumption that most STEM students seek out degrees with the intention of getting a job in their field. The results suggest that engineering employers require accreditation more often than their computing counterparts.

As part of the larger picture, this raises the question if ABET accreditation is as important as other job requirements for computing disciplines.

## LIMITATIONS

The job postings analyzed in this paper were scraped in a very limited time frame. Both datasets were pulled in November and December of 2019 and show a snapshot of only that time of year, as well as only those days. Observing if these requirements could change over time could yield more insight.

Other requirements were not taken into consideration when analyzing the ads. This includes whether a bachelor's degree was required, as well as any pertinent certifications.

Finally, from a logistical perspective, the number of ads that could be scraped at any one time was limited by the amount of requests the website would allow at one time.

## CONCLUSION

The results of the test demonstrate that there is evidence that ABET accreditation is a requirement in more engineering jobs than computing jobs. In the larger picture, it is suggested that, for computing disciplines, it may not be as worthwhile to the student that seeks post-graduate employment to prioritize accreditation. These results were limited by the short time frame and a narrow analysis that ignored other important factors in the ads themselves.

## REFERENCES

- [1] ABET, Inc., "Accreditation," *ABET*. [Online]. Available: <https://www.abet.org/accreditation/>. [Accessed: 29-Oct-2019].
- [2] ABET, Inc., "Criteria for Accrediting Computing Programs, 2019 – 2020," *ABET*. [Online]. Available: <https://www.abet.org/accreditation/accreditation-criteria/criteria-for-accrediting-computing-programs-2019-2020/>. [Accessed: 29-Oct-2019].
- [3] "Architecture and Engineering Occupations : Occupational Outlook Handbook," *U.S. Bureau of Labor Statistics*, 04-Sep-2019. [Online]. Available:

- <https://www.bls.gov/ooh/architecture-and-engineering/home.htm>. [Accessed: 20-Nov-2019].
- [4] A. P. Carnevale, T. Jaysundera, and D. Repnikov, “Understanding Online Job Ads Data: a Technical Report,” 2014.
- [5] B. Brittingham, “Accreditation in the United States: How did we get to where we are?,” *New Directions for Higher Education*, vol. 2009, no. 145, pp. 7–27, 2009.
- [6] “Computer and Information Technology Occupations : Occupational Outlook Handbook,” *U.S. Bureau of Labor Statistics*, 04-Sep-2019. [Online]. Available: <https://www.bls.gov/ooh/computer-and-information-technology/home.htm>. [Accessed: 15-Nov-2019].
- [7] G. Fisher, “Rethinking ABET Accreditation of Computer Science Degree Programs,” *2017 ASEE Annual Conference & Exposition Proceedings*, 2017.
- [8] B. S. Goda and C. Reynolds, “Improving Outcome Assessment in Information Technology Program Accreditation,” *Journal of Information Technology Education: Innovations in Practice*, vol. 9, pp. 049–059, 2010.
- [9] “History,” *CSAB, Inc.* [Online]. Available: <http://www.csab.org/history.html>. [Accessed: 29-Oct-2019].
- [10] P. G. Lovaglio, M. Cesarini, F. Mercurio, and M. Mezzanzanica, “Skills in demand for ICT and statistical occupations: Evidence from web-based job vacancies,” *Statistical Analysis and Data Mining: The ASA Data Science Journal*, vol. 11, no. 2, pp. 78–91, Jun. 2018.
- [11] M. Oudshoorn, R. K. Raj, S. Thomas, and A. Parish, “The Value of ABET Accreditation to Computing Programs,” *2018 ASEE Annual Conference and Exposition*, 2018.
- [12] E. Pitukhin, A. Dyatlova, A. Tulaeva, and A. Varfolomeyev, “Information Technology Employers Analysis: The Case Study Of The North-West Of Russia,” *Proceedings of the ICERI2017 Conference*, 2017.
- [13] S. Sirisuriya, “A Comparative Study on Web Scraping,” *Proceedings of 8th International Research Conference*, Nov. 2015.

**Sustainability, SCM,  
Quality Management, and  
Logistics - Abstracts**

# A Decomposition Algorithm for Deterministic Multi-Item Dynamic Lot Sizing Problems

---

Regular Session

---

***Dr. Hadi Farhangi***<sup>1</sup>

*1. Savannah State University*

Dynamic Lot Sizing (DLS) problem is one of the well studied problems in the literature. This problem decides the production quantities and inventory levels on multiple periods of planning. In this work, we consider a multi-item DLS problem and provide a decomposition algorithm to solve the problem exactly. We then compare the computational time of the decomposition algorithm with the Cplex method.

# **An Exploratory Study of the Prevalence of Campus-Based Food Pantries in the Southeast U.S.**

---

Poster

---

***Mr . William Teasley <sup>1</sup>, Dr . Morgan Shona <sup>1</sup>, Dr . Lauren Davis <sup>1</sup>***

*1. North Carolina Agricultural and Technical State University*

Food insecurity is a condition that describes the “limited or uncertain availability of nutritionally adequate and safe foods, or the ability to acquire such foods in a socially acceptable manner” (United States Department of Agriculture, 2015). Nationwide, food insecurity is a significant problem affecting more than 40 million U.S. households (Map the Meal Gap Executive Summary, Feeding America). An emerging demographic studied in the open literature regarding food insecurity is the postsecondary education student. Our work examines the prevalence of campus-based food pantries in the southeast United States. We our an initial classification of three North Carolina pantries as a results of face-to-face visits and interviews. Our work is an important first step to understand how campus-based food build organizational capacity to fulfill their objectives.

# APPLICATION OF SUPER EFFICIENCY BASED-CROSS EVALUATION METHOD FOR DISASTER RECOVERY CENTER LOCATION-ROUTING DESIGN PROBLEM

---

Oral

---

*Prof. Hong Jae-Dong*<sup>1</sup>, *Dr. Jeong Kiyoun*<sup>2</sup>

*1. South Carolina State University, 2. University of Houston Clear Lake*

This paper studies the disaster recovery center location-routing (DRCLR) design problem with four major performance measures (PMs). We develop a goal programming (GP) model and propose a procedure of combining the GP model into super efficiency based-cross evaluation (SEBCE) method for designing efficient DRCLR configurations. Solving the GP model for various values of weights generates several alternative options. Considering each option as a Decision-Making Unit (DMU), we apply SEBCE method to find the most efficient schemes. A case study using actual data for South Carolina is conducted to evaluate the proposed procedure.



## **Brick and Mortar Retailer's Quantity Commitment in the competition against E-tailer**

---

Regular Session

---

***Dr . Zhaoqiong Qin <sup>1</sup>, Dr . Wen-Chyuan Chiang Chiang <sup>2</sup>, Dr . Robert Russell <sup>2</sup>***

*1. Savannah State University , 2. University of Tulsa*

Quantity commitment chosen by firms in competition has been demonstrated by previous studies to mitigate price competition. This study investigate how the brick mortar retailer responds to quantity commitment when the competition comes from the E-tailer which has enough capacity to meet the demand due to short lead time, or adopting just-in-time systems. We find that the retailer always commits to the quantity.

# Determining surface compliance in the oil and gas industry utilizing drone and field imagery

---

Regular Session

---

*Dr . Chris Baynard <sup>1</sup>, Mr . Robert Richardson <sup>1</sup>, Mr . Nico Baynard <sup>1</sup>, Prof . Robert Schupp <sup>1</sup>, Mx . Rebecca Weiner <sup>1</sup>*

*1. University of North Florida*

Oil and gas exploration and production activities can create large-scale and permanent landscape effects related to the construction of wellpads. These flat, often rectangular cleared areas house infrastructure features such as pumps, storage tanks, waste pits, compressors and flares, and in turn are linked to each other and other transportation corridors through a series of access roads. The resulting network can fragment the landscape, leading to reduction in habitat and species diversity, as well as potential soil, water, air and visual pollution. In our study areas of the US West: Colorado, Wyoming and North Dakota, the US Forest Service (FS) is in charge of conducting surface inspections, as well as determining compliance during remediation when operations have ceased. A main challenge facing the FS is having insufficient personnel to oversee large amounts of land, leading to limited inspections per year. In this paper, we propose a solution based on in-situ imagery acquisition utilizing UAVs (drones) and aerial photography to gather low-altitude high-resolution imagery that FS personnel and regulators can examine in their home office. We expect that these datasets will allow regulators and industry to determine if oil and gas wellpads are in compliance by up to 80%. This will reduce the number of field visits to remote areas, as well as exposure to potentially lethal gases such as hydrogen sulfide (H<sub>2</sub>S), and help identify priority areas for site inspections. Furthermore, this spatial inventory can provide various perspectives for visual and spatial analysis over time and increase the number of operations that are monitored in a given season.

# DEVELOPMENT OF A LEAN LOGISTIC ASSESSMENT AND ANALYTICS TOOL

---

Regular Session

---

***Ms . Diana Sanchez <sup>1</sup>, Dr . Edie Schmidt <sup>2</sup>, Dr . Kimberly Deranek <sup>2</sup>***

*1. Demand Planner, Riduco Plastics , 2. Nova Southeastern University*

This study examined logistical best practices and critical success factors to develop an assessment tool to rate the maturity of the current and desired states of lean logistics operations in small and medium enterprises. The tool consists of 48 best practices classified into eight critical factors: Inventory, Transportation, Administration, Information Systems, Warehouse, Forecasting, Packaging and Supplier Network. The best practices and critical factors were developed through literature review with a comparative analysis to define commonalities. The assessment tool will be created, validated by subject matter experts using different criteria, including: clarity, content accuracy, relevance, content validity, bias avoidance, appropriateness of language, and clarity of instructions.

# Evaluating the Feasibility of a food hub in the Midlands of South Carolina

---

Regular Session

---

*Dr . Feng Keli*<sup>1</sup>

*1. South Carolina State University*

Food hubs provide aggregation and distribution services for local small and midsize farmers and emerge as a new business model in the regional food supply chain systems. In the past decade, food hubs grow significantly in the United States. According to the recent USDA study, approximately 220 food hubs are operating across the nation, and the number of food hubs increased 68 percent since 2008. There are several food hubs in the Upstate and Lowcountry regions of South Carolina. However, no food hub exists in the Midlands of South Carolina. In this study, we aim at evaluating the feasibility of a new food hub in Orangeburg County, SC, and the surrounding areas. Through surveys, this study evaluates the local farmers' interests and their needs and examines the drivers and obstacles for creating a food hub in the region.

# EXAMINING THE RELATIONSHIP BETWEEN FIRM INNOVATIVENESS AND SUPPLY CHAIN RESILIENCE

---

Regular Session

---

*Dr . Sergey Ponomarov*<sup>1</sup>

*1. Citadel*

This research investigates the relationship between firm innovativeness and supply chain resilience within a supply chain disruptions context.

Despite its potential benefits in wide range of circumstances, firm innovativeness received scant attention in relation to risk management. Likewise, a system view of resilience was overlooked in the strategic management literature. This research focuses on exploring the relationship between firm innovativeness and supply chain resilience in an attempt to incorporate supply chain resilience to strategic management and facilitate bridging the gap between innovation and supply chain risk management research streams. The moderating role of supply uncertainty and interdependence in the focal relationship was also hypothesized and tested. Findings suggest that firm innovativeness is positively associated with supply chain resilience, and supply uncertainty negatively moderates this relationship but interdependence does not. We argue that this could be due to dual nature of interdependence in supply chain networks.

A dynamic capabilities theory, serving as a theoretical lens, facilitates the discussion on the nature of firm innovativeness and supply chain resilience and informs the development of the proposed conceptual model.

KEYWORDS: Supply chain resilience, risk management, supply chain disruptions, innovativeness

# Implementing Enterprise Resource Planning System in a Small Enterprise: an Application Case in Mobile Housing Manufacturing

---

Oral

---

*Ms . Susanne Reeg<sup>1</sup>, Dr . Serina Al Haddad<sup>1</sup>*

*1. Rollins College*

An Enterprise Resource Planning (ERP) system is a software that is used by organizations to integrate functions in diverse departments, such as accounting, supply chain management, risk management, project management, and human resources. Consequently, an ERP system can prevent data duplication and provide data from a single source (Aremu, Shahzad, & Hassan, 2018). This research reviews the existing literature on implementing Enterprise Resource Planning (ERP) systems in Small and Medium Enterprise (SMEs) in the construction manufacturing sector. It also includes assessing specific needs of the mobile housing manufacturing industry and how they affect the decision of what ERP system to use. Furthermore, it presents an application case on ERP system implementation for World Housing Solution, a company that manufactures mobile housing structures and does not use an ERP system. The case study assesses current workflows in the company and if the company needs an ERP system to operate more efficiently. It concludes with a suggestion for an ERP system tailored to the company's needs. The research is led by two research questions:

R1: Would using ERP be beneficial for a small enterprise in the mobile housing manufacturing industry?

R2: When should mobile housing manufacturers implement an ERP system?

# INFORMATION SHARING FOR SUPPLIER INTEGRATION: AN EMPIRICAL STUDY

---

Regular Session

---

*Mr . Osam Sato <sup>1</sup>, Mr . Yoshiki Matsui <sup>2</sup>*

*1. Tokyo Keizai University , 2. Open University of Japan & Yokohama National University*

The importance of supply chain management (SCM) is increasing in Industry 4.0 era to adapt competition in industries. Supply chain integration (SCI) is the key to realize effective SCM and improve supply chain performance (SCP). Effective SCI improves competitiveness. SCI is one of the key SCM practices. Also, information sharing is one of the most critical elements of SCM. Supply chain information sharing (SCIS) with suppliers (ISS) is a critical antecedent of SCI and SCM. Past researches claim that intra-organizational coordination is antecedent of external coordination and SCI, and information sharing by suppliers is necessary to realize supplier integration. Plants share Information with suppliers that include many aspects such as delivery, demand change, inventory, schedule, quality and more. The purchase department must be able to access this information.

On the base of the above inference and past research results, we conducted an empirical study with data in hand to confirm the above scenario. We employ version 4 dataset of the High-Performance Manufacturing (HPM) project and apply it to structural equation modeling (SEM) analysis. This study reports the result.

The contributions of this study are as follows. First, although internal (intra-) coordination is an antecedent of inter-organizational (external) coordination for SCM, the process between these two constructs has not studied in detail. This study reveals the process sequence. Second, the process is an information-sharing process of both internal (intra-) and inter-organization. Also, they must be both IT and non-IT processes. This information must contribute to inter-organizational coordination. Our model includes these paths, reveals the significant relationship and sequence, and satisfies good model fitness.

# Inverse Optimization in p-Median Models

---

Regular Session

---

***Dr . Jaehwan Jeong <sup>1</sup>, Dr . Joyendu Bhadury <sup>1</sup>***

*1. Radford University*

Economic development in practice often needs to improve an existing transportation network to make a selected site the optimal location. In this talk, we present a model that begins with the question: what investments are needed in a transportation network to make selected site(s) the 1(p) – median on the network. Our model is formulated as an inverse optimization problem and present a non-metaheuristic solution methodology followed by a superior solution algorithm that uses a network editing technique. Empirical results are also presented.



# Investigating the impact of increased consumer shipping on the hospital supply chain

---

Regular Session

---

***Dr . Kim Whitehead <sup>1</sup>, Dr . John Frazier <sup>1</sup>***

*1. Anderson University*

This research addresses the impact of increased e-commerce and direct to consumer shipping on the availability of carriers and their ability to provide timely and dependable deliveries to hospitals. The hospital supply chain has been significantly impacted by the increase in e-commerce packages shipped via common carrier (e.g. USPS, UPS, FEDex and DHL). This is caused by a bloat of packages in the system. This impact has caused delays so impactful that they can force surgeries to be canceled and patient care to be negatively affected. This research helps to define the issue, its root causes and possible solutions. Delays in shipping hospital supplies affects the hospitals' ability to get timely deliveries of everyday items and items that are critical such as biological items needed for surgeries and treatments for patients. Ultimately, these delays affect patients, hospital costs and has even increased costs to health insurance causing ripple effects for the entire economy. There are opportunities for common carriers and logistics companies to provide services directed to hospitals however, to date, their costs are a barrier to their utilization. Research is required in this arena to help hospitals and carriers to understand the issues and work together toward solutions. This research has begun through interviews with hospital administrators and via meeting with Association of Health Care Resource and Materials Management Professionals (AHRMM) and the South Carolina Society of Hospital Materials Management (SCSHMM). These interviews have provided information that can be used to create and utilize a survey that can be sent to hospital materials management professionals to help understand the issue, its impact and possible solutions. Executives that represent the carriers or have experience working with the referenced parcel carriers will also be interviewed to further this research. This research is funded by a research grant from the Council of Supply Chain Management Professionals (CSCMP).

# INVESTIGATION OF THE SUPPLIER SELECTION CRITERIA IN PERFORMANCE-BASED LOGISTICS CONTRACTS

---

Regular Session

---

***Dr . Hasan Uvet <sup>1</sup>, Mr . HASAN CELIK <sup>2</sup>, Mr . Saban Adana <sup>2</sup>, Mr . Sedat Cevikparmak <sup>2</sup>***

*1. School of Business, Georgia Gwinnett College, Lawrenceville, Georgia , 2. G. Brint Ryan College of Business, University of North Texas, Denton, Texas*

Performance-based logistics (PBL) is a support strategy used to achieve measurable performance outcomes. In PBL, suppliers can increase their profit by attaining the system performance goal, while the buyers can lower the system cost with assured system availability. The dynamics of the PBL environment create an uncertain relationship of dependence to the supplier in PBL contracts. Therefore, the selection of the best providers is getting more significant for buyers. A current study aimed to explore supplier selection criteria in PBL. The goal achieved by examining of selection criteria of performance providers based on a literature review of non-PBL and PBL supplier selection criteria and examination of awarded PBL contracts in the defense industry. We found that nine selection criteria for the convenient provider for the defense industry in PBL.

## Real-time value network visibility

---

Regular Session

---

***Prof. Markus Gerschberger***<sup>1</sup>

*1. University of Applied Sciences Upper Austria - JRC LIVE*

By visualizing and analyzing a complete distribution network of a global car manufacturer (=several thousand nodes), we identify critical nodes and paths. Our study

1) enables managers to create awareness of criticality in order to prevent and/or mitigate future potential disruptions,

2) shows how to utilize available information to monitor visualized networks.

# The impact of counterfeit risk management on supply chain performance in the healthcare sector: A preliminary empirical analysis

---

Regular Session

---

*Dr . Falasca Mauro <sup>1</sup>, Dr . Scott Dellana <sup>1</sup>, Dr . John Kros <sup>1</sup>, Dr . William Rowe <sup>1</sup>*

*1. East Carolina University*

The purpose of this paper is to develop and test a model that explores the relationships among supply chain (SC) counterfeit risk management and supply chain performance in the healthcare sector. In the proposed theoretical model, SC counterfeit risk management is characterized by factors of healthcare SC counterfeit risk orientation, healthcare SC counterfeit risk mitigation and healthcare SC risk management integration, while supply chain performance is represented by healthcare logistics performance and healthcare organization overall performance. Structural equation modeling and survey data from 44 health care supply chain managers are used to test the research hypotheses. Healthcare SC counterfeit risk orientation was found to have a significant direct positive effect on healthcare SC counterfeit risk mitigation. Healthcare SC risk counterfeit risk mitigation had a significant direct positive effect on healthcare SC risk management integration. With respect to healthcare logistics performance, healthcare SC counterfeit risk mitigation had an insignificant direct positive effect, while healthcare SC risk management integration was found to have a significant direct positive effect. Finally, healthcare logistics performance had a significant direct positive effect on healthcare organization overall performance. Preliminary empirical results thus confirm the critical mediating role of SC counterfeit risk management integration in the healthcare sector. The study findings provide a relevant foundation for further research and practice in a current and relevant healthcare supply chain management topic.

# The Role of Collaboration and Efficiency on Firm Performance: A Supply Chain Managers Perspective

---

Regular Session

---

*Dr . Suman Niranjana<sup>1</sup>, Dr . Katrina Savitskie<sup>2</sup>, Mr . Saad Bani Hani<sup>3</sup>*

*1. G. Brint Ryan College of Business, University of North Texas, Denton, Texas , 2. University of West Florida , 3. University of North Texas*

In the contemporary global arena, sustained competitive advantage enables firms to maintain continuity within a highly competitive environment. Knowledge, innovation and supply chain capabilities are critical to outpace competitors for the organization to survive. Prior supply chain management studies indicate an increasing interest in supply chain collaboration efforts by examining the collaboration process and joint decision-making initiatives, along with techniques that lead to better agreements among firms. Firms pursue the aforementioned activities with the goal of improving performance across many dimensions, including better on-time delivery, improved inventory turns, reduced purchase cost, improved responsiveness, and reduced total cost. Collaboration between supply chain parties improves the shared logistics processes and enhances the efficiency of the supply chain which impacts firm performance.

This exploratory study was conducted to assist supply chain firms in understanding the role of Process Resource Collaboration, Joint Decision Making, and Agreement on Supply Chain Performance via the mediating role of Efficiency and the moderating role of Supply Chain Integration Tools. The authors examined how the interaction of the study's constructs impacts overall firm performance. The goal of this research was to improve the supply chain managers' understanding of where to invest their time and effort to achieve better firm performance. Covariance based structural equation modeling using LISREL 9.3 was conducted to support the hypothesized conceptual model and provide some recommendation for a future researcher. The model was tested with data collected from 105 experienced US-based supply chain managers.

**Sustainability, SCM,  
Quality Management, and  
Logistics - Papers**

## APPLICATION OF SUPER EFFICIENCY BASED-CROSS EVALUATION METHOD FOR DISASTER RECOVERY CENTER LOCATION-ROUTING DESIGN PROBLEM

Jae-Dong Hong, Industrial Engineering, South Carolina State University,  
Orangeburg, SC 29117, 803-536-8861, [jhong@scsu.edu](mailto:jhong@scsu.edu)  
Ki-young Jeong, Engineering Management, University of Houston Clear Lake,  
Houston, TX 77058, 281-283-3862, [jeongk@uhcl.edu](mailto:jeongk@uhcl.edu)

### ABSTRACT

This paper studies the disaster recovery center location-routing (DRCLR) design problem with four major performance measures (PMs). We develop a goal programming (GP) model and propose a procedure of combining the GP model into super efficiency based-cross evaluation (SEBCE) method for designing efficient DRCLR configurations. Solving the GP model for various values of weights generates several alternative options. Considering each option as a Decision Making Unit (DMU), we apply SEBCE method to find the most efficient schemes. A case study using actual data for South Carolina is conducted to evaluate the proposed procedure.

**Keywords:** Disaster recovery center location-routing, Goal Programming Model, Super Efficiency Based-Cross Evaluation Method

### INTRODUCTION

Due to today's globalized, more complex supply chain systems, and highly-uncertain business environment, supply chains have become susceptible to disruptions (see Peng et al. [19]). A significant stream of research on supply chain network structure related to disruption management focuses on facility location/allocation and routing (DRCLR) decisions. Especially, the data in Figure 1, which was developed by the National Oceanic and Atmospheric Administration's National Climatic Data Center (NCDC), shows that on average, the United States experiences ten severe weather events per year exceeding one billion dollars in damage, compared to an annual average of only two such events throughout the 1980s. This analysis quantifies the loss from numerous weather and climate disasters including tropical cyclones, floods, drought & heat waves, severe local storms (i.e., tornado, hail, straight-line wind damage), wildfires, crop freeze events, and winter storms. Only weather and climate disasters, which cause losses of greater than or equal to 1 billion-dollars in calculated damage including Consumer Price Index (CPI) inflation adjustment, are included in this dataset. While this threshold is arbitrary, these billion-dollar events account for roughly 80% of the total U.S. losses for all combined severe weather and climate events (see Figure 2). In 2017, the U.S. experienced a historic year of weather and climate disasters. In total, the U.S. was impacted by 16 separate billion-dollar disaster events including three tropical cyclones, eight severe storms, two inland floods, a crop freeze, drought, and wildfire.

After catastrophic events such as natural disasters or terrorist attacks happened, it would be critical to have Disaster Recovery Centers (DRCs) nearby such that emergency supplies can be sent to the affected area promptly for a rapid recovery. As a part of such an endeavor, the Federal Emergency Management Agency (FEMA) in 2001 required every Florida County to identify potential

locations of DRCs (Dekle et al. [4]). FEMA is the US government agency responsible for dealing with large-scale disasters. A DRC is a readily accessible facility or mobile office where evacuees and victims of the catastrophic events can obtain assistance and relief goods. Some of the services that a DRC may provide are the following:

- Guidance regarding disaster recovery
- Clarification of any written correspondence received
- Housing Assistance and Rental Resource information
- Answers to questions, resolution to problems and referrals to agencies that may provide further assistance
- Status of applications being processed by FEMA.
- Small Business Administration (SBA) program information if there is an SBA Representative at the Disaster Recovery Center site.

Figure 1: Billion-Dollar Disasters by Type, from 1980-2018

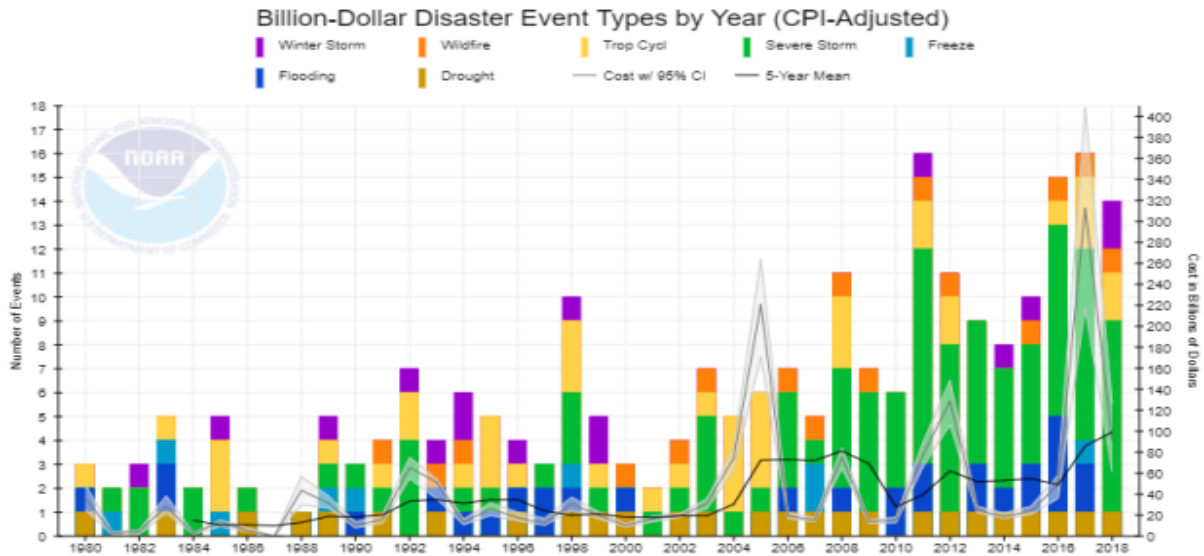

As Nagy and Salhi [18], who survey state of the art in DRCLR, stated, facility location-allocation (FLA) and routing problems are interrelated areas. Maranzana [16] points out that “the location of factories, warehouses and supply points in general ... is often influenced by transport costs.” Rand [21] insists that “many practitioners are aware of the danger of sub-optimizing by separating depot location and vehicle routing.” But both academics and practitioners often solve facility location-allocation problems, without consideration of underlying routing. In fact, various types of FLA models have been developed to answer the questions simultaneously such as how many facilities to locate, where to locate facilities, and how to distribute the items to the customers concerning different location criteria, assuming all customers are directly linked to a facility. Thus, DRCLR models are clearly and simultaneously related to FLA problems and routing problems. Schneider and Drex1 [23] define the standard DRCLR as a deterministic, static, discrete, single-echelon, single-objective DRCLR problem in which each customer must be visited exactly once for the delivery of a good from a facility, and in which no inventory decisions are relevant. They review the literature on the standard DRCLR literature published since the survey by Nagi and Salhi [18]. Following Schneider and Drex1 [23], Drex1 and Schneider [6] discuss variants and extension of the standard DRCLR, which include problems with stochastic and fuzzy data, multi-



period planning horizon, continuous location in the plane, multi-objective, more complex requests or route structures, such as pickup-and-delivery requests or routes with load transfers, and inventory decisions.

Figure 2: US Billion-Dollar Weather and Climate Disasters, 2017-2018

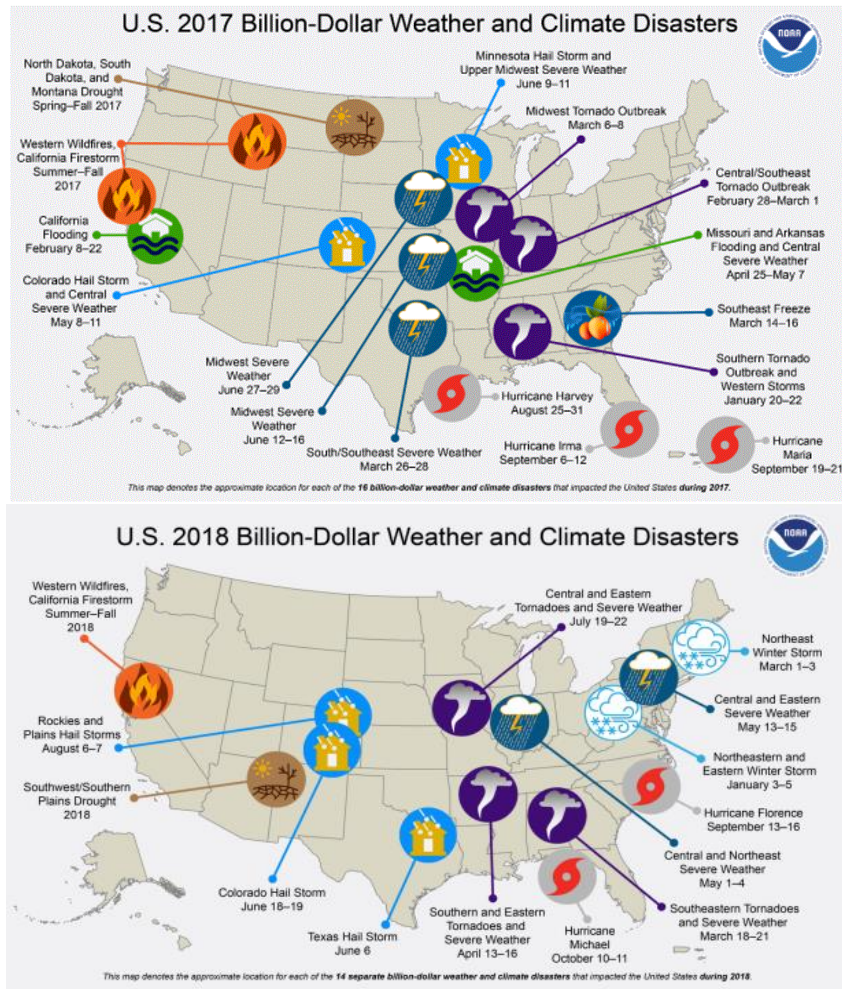

As many references cited in Current et al. [2], Farahani et al. [8&9], Fang and Li [7], and Manzini and Gebennini [15] demonstrate, the FLA problems are inherently multi-objective, where those objectives sometimes conflict with each other in nature. The traditional DRCLR models deal with the objective of cost-minimization, whereas demand-oriented objectives focus on measuring the ‘proximity or closeness’ of the facilities. The profit maximization objective may be achieved by either cost minimization or maximization of demand satisfied/covered, or both. Current et al. [2] emphasize the importance of multi-objective FLA (MOFLA) problems after observing the substantial growth of the literature on MOFLA problems. Thus, the growing attention and interest in these problems are due to the recognition of the need to consider more objectives/criteria to achieve closer solutions to reality.

Multi-objective programming (MOP) technique provides an analytical framework where a variety of objectives can be focused on simultaneously so that a decision-maker can use to provide optimal solutions. Contrary to a single objective optimization problem which can define the best solution, the notion of the best solution does not exist in the MOP problem. Most of the MOP techniques require decision-makers' judgment to provide weights to the deviational variables in the objective function to appropriately reflect the importance and desirability of deviations from the various target values. As the number of performance measures increases, solving the MOP model will yield a great number of alternative options. The reason is that each different weight factor set for performance measures may generate a different option. As Ragsdale [20] insists, no standard procedure is available to assign values to the weight factors in a way that guarantees the decision-makers find the most desirable solution. Evaluating alternatives generated by solving the MOP model can be viewed as a multiple-criteria decision-making (MCDM) problem, requiring a systematic solution evaluation system.

When the facilities are under the risk of disruptions, the expected demand covered/satisfied (EDC) would be one of the most important outputs. Contrary to the conventional total cost minimization approaches, we will formulate the DRCLR problem as the goal-programming (GP) model with the objective of simultaneously maximizing EDC and minimizing the total relevant cost (TRC), total routing distance (TRD), and the longest delivery distance (LDD). Solving the GP model with these four performance measures will generate several alternative options as the weight given to each performance measure. The subsequent question is which option is the most efficient one. Regarding efficiency, we generally define the efficiency to be the ratio of single output to a single input. Hong and Jeong [11] consider a facility location-routing design problem with three performance measures, TRC, TRD, and EDC, using the data envelopment analysis (DEA) method. This paper also utilizes DEA methodology, which yields relative efficiency scores (ESs) of comparable units, decision-making units (DMUs) employing multiple outputs and inputs. To denote the relative efficiency for each DMU, DEA produces an ES that is defined as the ratio of the sum of weighted outputs to the sum of weighted inputs. The proposed procedure is different from the approach of Klimberg et al. [13], in that we generate the inputs and outputs of DMUs directly by solving GP model for various values of the weight factor, whereas Klimberg et al. [13] assume those inputs and outputs are given or known.

DEA eventually determines which of the DMUs make efficient use of their inputs and produce outputs effectively and which do not. Thus, the DEA models classify DMUs into two groups which would separate relatively efficient DMUs from inefficient DMUs. For the inefficient DMUs, the analysis can quantify what levels of improved performance should be attainable. In addition, the analysis indicates where an inefficient DMU might look for benchmarking help as it searches for ways to improve. The highest ratio among all the DMUs would identify the most efficient DMU, and every other DMU would be rated by comparing its ratio to the highest one. However, a weakness of the DEA-based assessment is that a considerable number of DMUs are classified as efficient so that it may suffer from a lack of discrimination particularly. The main reason is that DEA, with its nature of the self-evaluation, allows each DMU to be evaluated with its most favorable weights and to even ignore unfavorable inputs/outputs.

As a DEA extension, the cross-efficiency (CE) method is suggested by Sexton et al. [24] to rank DMUs with the main idea of using DEA to do peer-evaluation, rather than pure self-evaluation in

DMU's usual DEA efficiency. But, a critical issue is that, as Doyle and Green [5] note in their paper, the non-uniqueness of CE scores due to the often-present multiple optimal DEA weights. The third issue is that the CE method frequently ranks inefficient DMUs ahead of the full efficient DMUs. Jeong and Ok [12] propose a modified cross-evaluation method using the super efficiency scores (SES) by utilizing the rank consistency to measure the performance of the proposed method and demonstrate their method can discriminate efficient DMUs better than CE-based methods.

The objective of this paper is to present and demonstrate how to combine DEA technique, super efficiency-based cross-evaluation (SEBCE) method and GP model for the efficient DRCLR decisions and patterns to help practitioners as well as decision-makers who are responsible for the strategic and operational decision plans. We solve the DRCLR problem for various values of weights given to the performance measures, EDC, TRC, TRD, and LDD. Considering each generated alternative option for a given set of weight as a DMU, we evaluate all alternative options by utilizing DEA techniques to find the efficiency of each DMU and identify the most relatively efficient DRCLR schemes. In this way, decision-makers evaluate and identify efficient and robust DRCLR decisions without any subjective judgment. Furthermore, once decision-makers identify efficient DRCLR patterns through the proposed procedure, they can modify their operational decisions without sacrificing the efficiency heavily under unexpected disruptions. We demonstrate our procedure through a case study.

### CASE STUDY

Historic flooding, which is so-called as a **1000-year storm** in South Carolina (SC), tore through SC in October 2015 when numerous rivers burst their banks, washing away roads, bridges, vehicles, and homes. Hundreds of people required rescue and the state's emergency management department urged everyone in the state not to travel (see Figure 3). Following this 1000-year storm, Hurricane Matthew, which is the most powerful storm of the 2016 Atlantic Hurricane Season, made its fourth and final landfall as a category 1 hurricane along the Carolina coast. Matthew was directly responsible for 29 deaths in Carolinas all but one due to flooding. In 2017, SC avoided Irma's eye; the massive storm caused severe flooding and tropical-storm-force winds. In 2018, Hurricane Florence caused severe damage in the Carolinas primarily as a result of freshwater flooding, causing 52 casualties in the Carolinas.

The Federal Emergency Management Agency (FEMA) opens disaster recovery centers (DRCs) in several SC counties to help SC flood survivors in case of flooding. We use the problem of locating DRCs in SC as our case study. Forty-six (46) counties are clustered based on proximity and populations into twenty counties. Then, one city from each clustered county based on a centroid approach was chosen. We assume that all population within the clustered county exists in that city. The distance between these cities is considered to be the distance between counties. We assume that when a major disaster is declared, the DRC in that county can't function due to the damaged facility and supply items and closed or unsafe roads and highways. The FEMA database provides a list of counties where a major disaster was declared. Based on the historical record and the assumption, the risk probabilities,  $p_j$ , for each site are listed in Table 1.

---

Table 1. Data for DRC Location-Routing Design Problem

---

No	City	County	Population (K)	Risk Probability	f <sub>j</sub> (\$K)
1	Anderson	Anderson/Oconee/Pickens	373	0.125	1800
2	Beaufort	Beaufort/Jasper	187	0.063	2000
3	Bennettsville	Marlboro/Darlington/Chesterfield	96	0.375	500
4	Conway	Horry	269	0.375	650
5	Georgetown	Georgetown/Williamsburg	93	0.438	550
6	Greenwood	Greenwood/Abbeville	92	0.125	1600
7	Hampton	Hampton/Allendale	33	0.188	1500
8	Lexington	Lexington/Newberry/Saluda	318	0.313	650
9	McCormick	McCormick/Edgefield	35	0.250	800
10	Moncks Corner	Berkeley	178	0.313	600
11	Orangeburg	Orangeburg/Bamberg/Calhoun	123	0.375	500
12	Rock Hill	York/Chester/Lancaster	321	0.313	600
13	Spartanburg	Spartanburg/Cherokee/Union	367	0.313	600
14	Sumter	Sumter/Clarendon/Lee	157	0.375	500
15	Walterboro	Colleton/Dorchester	135	0.250	700
16	Aiken	Aiken/Barnwell	184	0.313	500
17	Charleston	Charleston	350	0.250	1200
18	Columbia	Richland/Fairfield/Kershaw	461	0.375	650
19	Florence	Florence/Dillon/Marion	203	0.438	450
20	Greenville	Greenville/Laurens	521	0.125	1300

Figure 3: Historic 2015 South Carolina Flooding Map

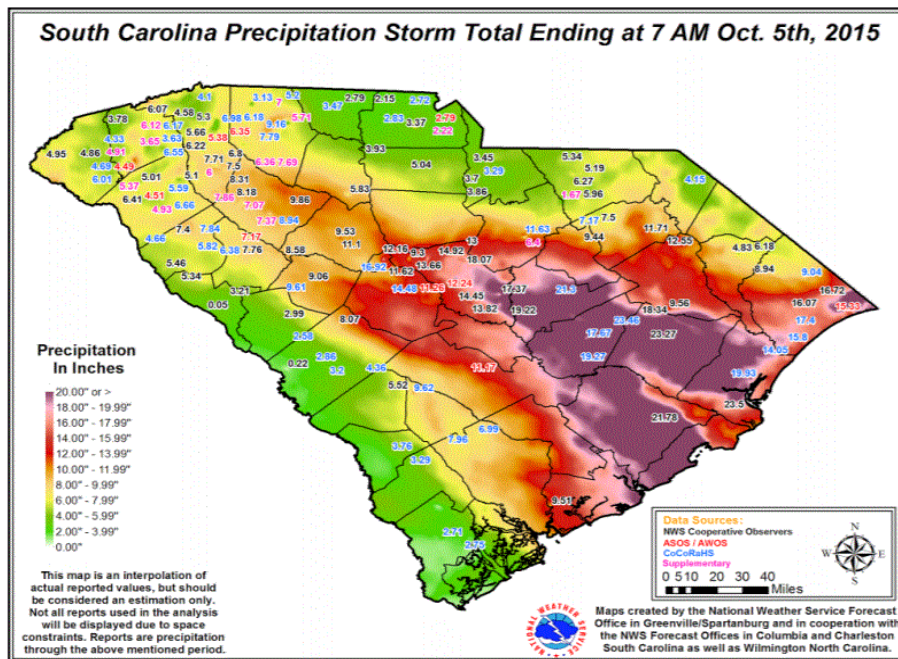

We solve the GP model for various values of  $\alpha$ , where each weight changes between 0 and 1 with an increment of 0.2. There are 56 configurations arising out of the combinations of the setting of  $\alpha$ . After 56 runs, we reduce 56 configurations into twenty-five (25) consolidated configurations, based on the values of the performance measures. Three efficient DMUs (configurations) in Level 1, DMU #22, #25, and #37, and nine DMUs in Level 2 are identified by solving the multiplier DEA model. Then, we construct the super cross-evaluation matrix in Table 3.

It is observed from Table 3 and 4 that DMU #25 in Level 1 ranks first for all cases so that it would be the most efficient DRCLR network scheme. The notable observations are that DMU #6 in Level 2 ranks second in terms of CESs and SCEs, while DMU #22 and #37 in Level 1 rank lower than some DMUs in Level 2. It would be a contradictory observation since DMUs in Level 1, which have a higher ES and SES, are considered to be more efficient than DMUs in the lower levels. To investigate further, we compute SCES for each DMU for various values of  $\beta$  and report them and the corresponding rankings in Table 4. From Table 4, we see that as  $\beta$ , the proportion of self-evaluation value, increases, DMU #22 in Level 1 ranks second, while DMU #6 in Level 2 ranks second for the less value of  $\beta$ .

From Table 4 and Figure 4, DMU #35 turns out to be a better scheme in terms of the inputs, TRC, TRD, and LLD, whereas DMU #27 is a better one regarding the output, EDC. We see that the scheme #2 with the perfect ES of 1.000, the second-highest CES of 0.941, and the highest AAS of 1.958 generates 1,517, \$1,906.18, 680 as the optimal values of *EDC*, *TRC*, and *TRD*, respectively. The optimal locations of two DRCs for the #2 are {Anderson, Beaufort} and the optimal allocation-routing sequence (ARS) from DRC {Anderson} is {Anderson-Greenwood-Lexington-McCormick-Anderson} or just a reverse sequence, that is, {Anderson-McCormick-Lexington-Greenwood-Anderson}. The optimal ARS from the other DRC {Beaufort} is {Beaufort-Hampton-Bennettsville-Conway-Georgetown-Moncks Corner-Beaufort} or a reverse sequence of it.

## SUMMARY AND CONCLUSIONS

In this paper, we study a facility location-allocation-routing (FLAR) design problem under the risk of disruptions. We consider three major performance metrics: the expected demand covered/satisfied (*EDC*), the total relevant cost (*TRC*) and the total routing distance (*TRD*). We develop a GP model for the FLAR problem, simultaneously considering these three performance measures. Considering *EDC* as output and *TRC* and *TRD* as two inputs, several DEA techniques, such as m-DEA, DEA-based stratification/context-dependent method, super efficiency, and cross-efficiency methods, are combined and applied to find the efficient and the most efficient FLAR network schemes among various alternatives generated by solving the GP model. Using a case study, we observe that the proposed procedure of combining the GP model and various DEA methods works very well, regarding identifying efficient schemes. The proposed approach to the FLAR design problem would provide many insights to practitioners as well as researchers. In addition, this approach could be applied to design various supply chain network system efficiently and effectively.

For future research, it would enhance this research if the concept of backup facilities for the case of shutdown of the facility is considered. That is how to mitigate the impact of disruptions on the

supply chain network system. In this paper, we assume all the routes are 100% reliable. In reality, the roads in the routes are not 100% reliable. Thus, it would surely enhance this research if the risk probabilities of routes are also considered simultaneously. It would also be interesting to include other goals, such as minimizing the maximum coverage distance on the route and minimizing the maximum demand-weighted coverage distance.

### **ACKNOWLEDGEMENTS**

This material is based upon work that is supported by the National Institute of Food and Agriculture, U.S. Department of Agriculture, under Evans-Allen project number SCX-313-04-18.

### **REFERENCES**

References are available upon request from Hong.

Table 3. SEBCE Score Table for DMUs in Levels 1 and 2

DMU	DMU											
	Level 1			Level 2								
	22	25	37	6	7	12	14	23	24	27	35	47
22	1.0075	1.0000	1.0000	0.8881	0.8183	0.7967	0.8187	0.9576	0.9661	0.8868	0.9204	0.9860
25	0.6177	1.1310	0.5788	1.0000	0.6359	0.7450	0.7450	0.7103	0.7028	0.5951	0.6657	0.5284
37	1.0000	1.0000	1.0018	0.8886	0.8500	0.8178	0.8399	0.9381	0.9394	0.9220	0.9388	0.9832
6	0.6557	1.0000	0.6631	0.8908	0.9129	0.9158	0.9158	0.6443	0.6132	0.8743	0.8184	0.6018
7	0.6557	1.0000	0.6631	0.8908	0.9129	0.9158	0.9158	0.6443	0.6132	0.8743	0.8184	0.6018
12	0.6557	1.0000	0.6631	0.8908	0.9129	0.9158	0.9158	0.6443	0.6132	0.8743	0.8184	0.6018
14	0.6557	1.0000	0.6631	0.8908	0.9129	0.9158	0.9158	0.6443	0.6132	0.8743	0.8184	0.6018
23	1.0000	1.0000	0.9915	0.8881	0.8150	0.7952	0.8169	0.9531	0.9613	0.8814	0.9158	0.9764
24	1.0000	1.0000	0.9915	0.8881	0.8150	0.7952	0.8169	0.9531	0.9613	0.8814	0.9158	0.9764
27	0.9982	1.0000	1.0000	0.8886	0.8502	0.8181	0.8401	0.9366	0.9376	0.9219	0.9383	0.9811
35	0.9982	1.0000	1.0000	0.8886	0.8502	0.8181	0.8401	0.9366	0.9376	0.9219	0.9383	0.9811
47	1.0000	0.9382	1.0000	0.8335	0.7911	0.7577	0.7804	0.9300	0.9401	0.8707	0.8963	0.9968
SEBCES <sup>1</sup>	0.8397	0.9944**	0.8376	0.8942*	0.8331	0.8265	0.8405	0.8127	0.8034	0.8597	0.8604	0.8018
SEBCES <sup>2</sup>	0.8537	1.0058**	0.8513	0.8939*	0.8398	0.8339	0.8468	0.8244	0.8166	0.8649	0.8669	0.8180

SEBCES<sup>1</sup>: SEBCE score with peer-evaluation only. SEBCES<sup>2</sup>: SEBCE score with self- and peer-evaluation.

\*\* : Ranked First. \* : Ranked Second

Figure 4: Efficient DRC Location-Allocation-Routing Network Schemes

DMU #25

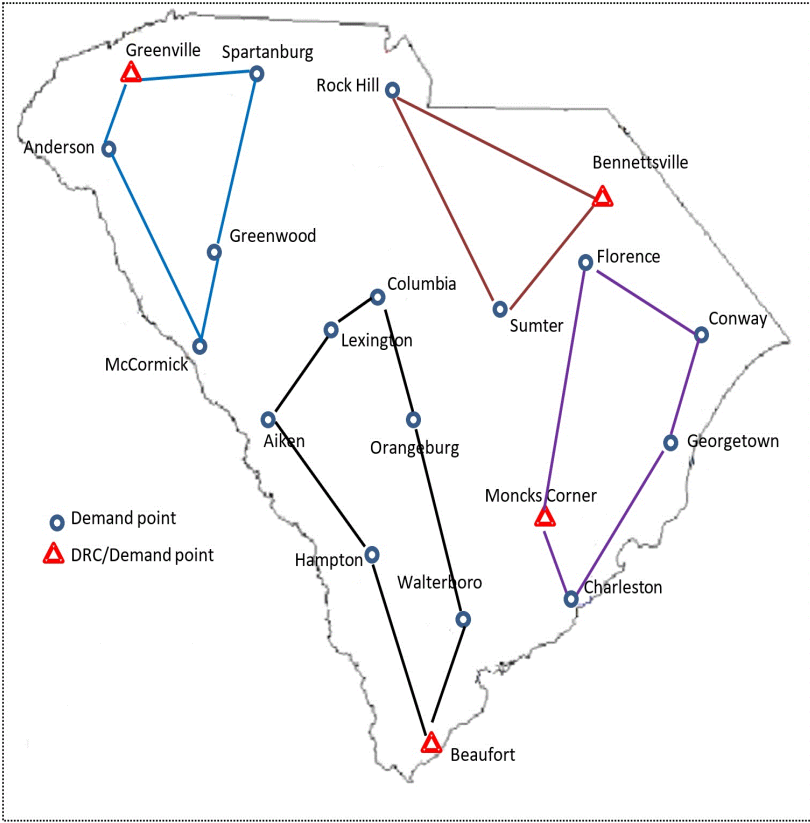



## **DEVELOPMENT OF A LEAN LOGISTIC ASSESSMENT AND ANALYTICS TOOL**

Diana Sanchez, Demand Planner, Riduco Plastics, Carrera 32 # 107017, Manizales, Caldas-Colombia 170003 [diana.sanchezr@gmail.com](mailto:diana.sanchezr@gmail.com), 57-316-760-5584

Edie Schmidt, Professor, Nova Southeastern University, H. Wayne Huizenga College of Business and Entrepreneurship, College of Business and Entrepreneurship, 3301 College Avenue, Fort Lauderdale, Florida 33314-7796, [eschmidt@nova.edu](mailto:eschmidt@nova.edu), 765-490-6587

Kimberly Deranek, Associate Professor, Nova Southeastern University, H. Wayne Huizenga College of Business and Entrepreneurship, 3301 College Avenue, Fort Lauderdale, Florida 33314-7796, [kderanek@nova.edu](mailto:kderanek@nova.edu), 954-262-5151

### **ABSTRACT**

This study examined logistical best practices and critical success factors to develop an assessment tool to rate the maturity of the current and desired states of lean logistics operations in small and medium enterprises. The tool consists of 48 best practices classified into eight critical factors: Inventory, Transportation, Administration, Information Systems, Warehouse, Forecasting, Packaging and Supplier Network. The best practices and critical factors were developed through literature review with a comparative analysis to define commonalities. The assessment tool will be created, validated by subject matter experts using different criteria, including: clarity, content accuracy, relevance, content validity, bias avoidance, appropriateness of language, and clarity of instructions.

### **INTRODUCTION**

Lean Manufacturing is a management strategy that has helped many companies to thrive under extreme competitive conditions. In general, lean techniques reduce costs and increase productivity by eliminating waste within the manufacturing environment [16]. The application of lean techniques in other environments has attracted the interest of many researchers as well as practitioners [13]. However, the adaptation of lean techniques in logistics operations in small and medium companies is an area that needs further research. This study provides preliminary research for the development of an assessment tool to analyze lean logistics best practices in small and medium enterprises (SMEs) in the manufacturing sector.

The benefits that result from lean logistics implementation are: higher customer satisfaction due to incremented fill rate, higher visibility in the supply chain and better performance measurement, higher inventory turns and reduced inventory levels, cost reduction in warehousing and transportation, better supplier performance, and supply chain total cost reduction [10].

Many studies on lean systems and lean logistics have been generated through research in large enterprises (LEs) with global operations. In recent years, SMEs started to face challenges in competition that have prompted them to adopt lean to enhance their competitiveness [17]. However, there is little evidence about how the lean practices

were implemented into SMEs, which limits the possibility of creating a broadly applicable lean logistics theory [8].

Approaching lean logistics from the SMEs perspective could generate a better understanding of the challenges and risks these firms face when competing with LEs in a global economy. Recognizing their own strengths, weaknesses, opportunities and threats would be useful in the creation of a lean logistics roadmap or implementation plan that would help SMEs recognize their current state and visualize the desired state that they expect to achieve.

### **STATEMENT OF PURPOSE**

This exploratory study identifies criteria to be embedded in a logistics assessment tool used to analyze the maturity of the current and desired states of lean logistics operations in a company.

### **PROBLEM STATEMENT**

Lean Manufacturing focuses on reducing waste while meeting customer expectations. Many companies have encountered difficulties in the attempt to apply lean, including absence of direction and planning and inadequate project sequencing [2]. The successful implementation of lean philosophy does not necessarily require discipline to a system or tools or a lean culture. Lean philosophy requires reframing our point of view as we manage the company logistics processes [4].

One important component in the SC is logistics. According to [1], logistics is comprised of all the operations needed to deliver goods or services, except making the goods or performing the services. Logistics encompasses everything that happens outside the manufacturing walls, including the flow of materials from the suppliers (known as inbound logistics), the flow of materials to the customers (known as outbound logistics), and the flow of the associated information. Lean logistics is defined as the logistics dimension of lean manufacturing. Its main objective is to deliver the right materials to the right locations, in the right quantities and in the right presentation; and do it all efficiently. The benefits of the application of lean logistics are evident. However, the disadvantages are the costs, hazards and challenges associated to these practices.

Few studies have been addressed lean logistics in SMEs. [15] addressed lean implementation and the criticality of information sharing and the importance of human resources in ME. Small and medium enterprises tend to provide information and knowledge sharing informally.

This research identifies best practices to be embedded in a lean logistics assessment and analytics tool for SMEs that will help them analyze their specific strengths, weaknesses, opportunities and threats in lean logistics practice. The tool will help companies identify barriers and opportunities for the implementation of lean logistics.

## **Lean Logistics Critical Factors for SMEs**

Many important areas or factors affect lean applications and the adaptation of logistics. [12] listed five function within logistics, including: 1) transportation, 2) operations, 3) inventory, 4) information, and 5) special functions.

[14] evaluated 65 companies in 9 areas in the manufacturing environment: 1) inventory, 2) team approach, 3) processes, 4) maintenance, 5) layout/handling, 6) suppliers, 7) setups, 8) quality, 9) scheduling, and 10) control. Although the intent of this study was not to focus on lean application in the manufacturing environment, some of the factors have a great impact on the logistics operations as well.

[5] summarized the principal components of logistics literature as: 1) integration of material and information flow, 2) JIT, MRP, waste removal, VMI, 3) physical distribution, 4) cross docking, 5) logistics postponement, 6) capacity planning, 7) forecast information management, 8) distribution channel management, and 9) planning and control of material flow.

[7] classified logistics wastes through seven factors: 1) inventory, 2) transportation, 3) space and facilities, 4) time, 5) packaging, 6) administration, and 7) knowledge. Finally, [1] organized his book throughout the following topics: 1) transportation, 2) warehousing, 3) material flow, 4) packaging, 5) information.

[3] discussed the importance of data capture in the logistics functions. They defined data capture as important technology to capture information about both the product and the process. The product data information might require collecting environmental data, including temperature and wait duration. Otherwise, transactional data related to inventory levels, and other supply chain metrics require data capture technology. Technology advances in the past ten years have greatly influenced logistical success. [6] investigated four dimensions of usage features as key user satisfaction factors. They further define the dimensions of information resource, platform technology, management service, and application effect to establish the relationship with user satisfaction. Capturing process or product information correctly requires a customized, rapid response logistics information platform, and a logistics platform technology that can interact with users anytime and anywhere.

Many assessment tools have been developed to evaluate SCM practices. The capability levels of these studies are a good starting point to help identify capability levels for lean logistics. The Supply Chain Operations Reference Model (SCOR) proposed by [9] describes five levels including ad hoc, defined, linked, integrated and extended.

## METHODOLOGY

This study identifies critical criteria to be included in an assessment tool to determine the maturity of lean logistics operations in SMEs. Initially, templates were evaluated to determine if an existing template would be a suitable starting point. The next activity was to identify the key elements or components that should be embedded in the tool that would eventually be used to evaluate the maturity level of lean logistics within SMEs with an emphasis on lean logistics objectives, critical factors, and best practices.

The first draft of the criteria was sent to five subject matter experts who agreed to participate in the study. The goal was to evaluate criteria consistent with the latest National Quality Council standards.

## RESULTS

A thorough literature review was performed to obtain definitions of the critical factors in logistics. Comparative tables were created to support the definition of the critical factors that were used in the creation of the lean logistics model. The critical factors were matched to logistics objectives to determine the roadmap that companies need to keep in mind when starting the lean logistics journey (Figure 1). The identified critical factors will be foundational to the creation of an assessment tool.

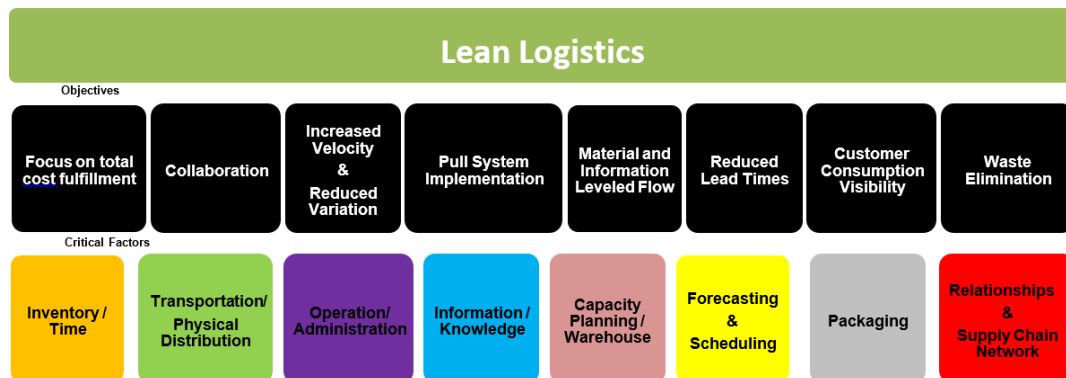

Figure 1 Lean Logistics Objectives and Critical Factors

### Research Question: Definition of lean logistics best practices

The best practices list was developed through a literature review. These best practices are general practices, meaning that they apply to any kind of enterprise without taking into account the size. However, in order to build the model, only the best practices that better fit SMEs were selected. This selection was based on the researcher discretion and three best practices per topic are listed below:

#### I. Inventory/ Time

- ✓ Keep the minimum inventory level minimum that guarantees production and final customer needs [1].
- ✓ Respond to customer orders by delivering small quantities more frequently will result in higher inventory turns [7].
- ✓ High inventory turns can be also be counterproductive since it may result in increased shipping costs. Therefore, the company needs to determine the cost of carrying inventory [7].

#### II. Transportation/ Material/ Physical distribution:

- ✓ The logistic system is designed to transfer small quantities of a large number of items [1].
- ✓ The company fosters partnerships with carriers that result in mutual benefits such as priority service and rate negotiations. The goal is lower system costs, not only transportation costs [7].
- ✓ When possible, shipments less-than-truckload (LTL) are planned in a way orders can be combined and transported by only one truckload carrier [7].

#### III. Operation/ Administration:

- ✓ Third party logistics (3PLs) are not utilized to offer services that require product knowledge [1].
- ✓ There are customer service policies established and are used to as a reference to make decisions that will affect customers' expectations [7].
- ✓ The company uses technological solutions that ease warehouse administration [7].

#### IV. Information/ Knowledge:

- ✓ Parts, either raw material or finished products, only moved to the next stop when a pull signal is activated, announcing that the destination is ready for them [1].
- ✓ The use of customized, rapid response logistics information platform, and logistical information systems that support market visibility by allowing direct communication between customers and suppliers [6].
- ✓ The exchange of information through ERP systems is used to enhance communications between customers and suppliers, where the forecast of finished goods might be considered orders, with a compensation agreement in case of consistent optimistic forecasts [1].

#### V. Warehouse:

- ✓ The company uses a combination of dedicated and allocates slots. Dedicated are used for high volume items, whereas allocated are used for other items [1].
- ✓ Items that are infrequently used have dynamic/random allocation [1].
- ✓ The warehouse Management System (WMS) in place supports different storage methods, and allows them to coexist in the same warehouse [1].

**VI. Forecasting and Scheduling:**

- ✓ Products are only moved to the next stop when a pull signal (for example, a purchase order) is activated, announcing that the destination is ready for them [7].
- ✓ Align the shipping and receiving schedules to match customer consumption (on the outbound side) with the pull of manufacturing material (on the inbound side) [11].
- ✓ For inbound logistics, different replenishment processes are assigned to different products to fit specific needs [11].

**VII. Packaging**

- ✓ The company prefers the use of returnable containers for packaging parts in transit instead of disposable containers [1].
- ✓ The company regularly revise the benefits obtained from the packaging that is currently in use, in aspects such as how difficult it is to pack, lift, carry, lower, unpack, and dispose of the container [7].
- ✓ Policies are in place to promote the use of returnable containers or recyclable packaging [7].

**VIII. Relationship & supply network**

- ✓ Supplier metrics are used to classify suppliers according to their performance in three categories: ethical, needing help to get certification, and candidates for replacement [1].
- ✓ The supplier metrics are based on delivery and quality, and not only on prices [1].
- ✓ The company negotiates with a small number of direct suppliers. Each one of these direct suppliers manages a group of small suppliers [1].
- ✓ The company does not source the same item from different suppliers. Instead, the company uses a single sourcing strategy, making the supplier responsible for second-sourcing agreements [1].

**FUTURE RESEARCH - BUILDING THE MODEL**

After all the information was identified and the research question completed, the next activity is to combine everything into the model. This step requires putting together one template for each of the critical factors, including the best practices defining each one. The combination of the research questions will provide all the elements required to create the assessment tool. The assessment tool will be used in several logistical enterprises and analyzed for similarities and differences across the critical factors. The tool will be evaluated using Gap analysis for refinement of the tool and the analytics output.

**SUMMARY**

Lean manufacturing is a management technique that has proven to be very effective not only in the manufacturing sector but also in many others type of businesses such as service

and healthcare. Lean techniques have demonstrated the ability to adapt from the production system to other areas or departments within the company including logistics. Lean techniques and lean logistics were reported to be very useful in LEs. However, these techniques (in SMEs) have not been broadly documented and published. SMEs are facing challenges in competition that have prompted evolution and adoption of better management techniques. However, SMEs have budget and resources constraints that limit their ability to develop their own tools to analyze management practices. The lack of skills, time and resources results in a narrow view of the company strategy, focusing on operational matters rather than planning. This exploratory research project identified criteria used as a basis for a self-assessment tool that will help SMEs rate key element and quantifies the maturity of lean logistics operations in SMEs in the manufacturing sector.

---

**REFERENCES**

- [1] Baudin, M. (2005). *Lean logistics: the nuts and bolts of delivering materials and goods*. Productivity Press.
- [2] Bhasin, S., & Burcher, P. (2006). Lean viewed as a philosophy. *Journal of Manufacturing Technology Management*, 17(1), 56–72.
- [3] Chaudhuri, A., Dukovska-Popovska, I., Subramanian, N., Chan, H. K., & Bai, R. (2018). Decision-making in cold chain logistics using data analytics: A literature review. *International Journal of Logistics Management*, 29(3), 839–861.
- [4] Chiarini, A., Baccarani, C., & Mascherpa, V. (2018). Lean production, Toyota Production System and Kaizen philosophy. *TQM Journal*, 30(4), 425–438.
- [5] Croom, S., Romano, P., & Giannakis, M. (2000). Supply chain management: an analytical framework for critical literature review. *European Journal of Purchasing & Supply Management*, 6(1), 67–83.
- [6] Fu, H., Lima, S., & Rocha, Á. (2018). Factors influencing user usage intention on intelligent logistics information platform. *Journal of Intelligent & Fuzzy Systems*, 35(3), 2711–2720.
- [7] Goldsby, T., & Martichenko, R. (2005). *Lean Six Sigma Logistics Strategic Development to Operational Success*. J. Ross Publishing, Inc.
- [8] Karlsson, C., & Åhlström, P. (1997). A lean and global smaller firm? *International Journal of Operations & Production Management*, 17(10), 940–952.
- [9] Lockamy, A., & McCormack, K. (2004). The development of a supply chain management process maturity model using the concepts of business process orientation. *Supply Chain Management: An International Journal*, 9(4), 272–278.
- [10] Martichenko, R. (2013). *The Lean Supply Chain: A Field of Opportunity - Inbound Logistics*.
- [11] Martichenko, R., & Grabe, K. Von. (2010). *Building a Lean Fulfillment Stream: Rethinking Your Supply Chain and Logistics to Create Maximum Value at Minimum Total Cost* (p. 111). Lean Enterprise Institute.
- [12] Ross, D. F. (1997). *Competing through supply chain management*. Springer.
- [13] Sternberg, H. (2013). Applying a lean approach to identify waste in motor carrier operations. *International Journal of Productivity and Performance Management*, 62(1), 47–65.
- [14] Taj, S. (2008). Lean manufacturing performance in China: assessment of 65 manufacturing plants. *Journal of Manufacturing Technology Management*, 19(2), 217–234.
- [15] Tortorella, G. L., Marodin, G. A., Fogliatto, F. S., & Miorando, R. (2015). Learning organisation and human resources management practices: an exploratory research in medium-sized enterprises undergoing a lean implementation. *International Journal of Production Research*, 53(13), 3989–4000.
- [16] Wanitwattanakosol, J., & Sopadang, A. (2012). Lean Manufacturing Systems in small and medium enterprises : A framework for lean tools integration. *International Journal of Mechanic Systems Engineering*, 2(2), 59–63.
- [17] Zhou, B. (2012). Lean principles, practices, and impacts: a study on small and medium-sized enterprises (SMEs). *Annals of Operations Research*, (Krafcik 1988), 1–18.



## **IMPLEMENTING ENTERPRISE RESOURCE PLANNING SYSTEM IN A SMALL ENTERPRISE: AN APPLICATION CASE IN MOBILE HOUSING MANUFACTURING**

Susanne Reeg, Rollins College, 1000 Holt Avenue, 32789 Winter Park, FL, sreeg@rollins.edu,  
+49-163-8640130

Serina Al-Haddad, Rollins College, 1000 Holt Avenue, 32789 Winter Park, FL,  
shaddad@rollins.edu, 407-646-1591

### **ABSTRACT**

An Enterprise Resource Planning (ERP) system is a software that is used by organizations to integrate functions in diverse departments, such as accounting, supply chain management, risk management, project management, and human resources. Consequently, an ERP system can prevent data duplication and provide data from a single source [1, p.245]. This research reviews the existing literature on implementing Enterprise Resource Planning (ERP) systems in Small and Medium Enterprise (SMEs) in the construction manufacturing sector. It also includes assessing specific needs of the mobile housing manufacturing industry and how they affect the decision of what ERP system to use. Furthermore, it presents an application case on ERP system implementation for World Housing Solution, a company that manufactures mobile housing structures and does not use an ERP system. The case study assesses current workflows in the company and if the company needs an ERP system to operate more efficiently. It concludes with a suggestion for an ERP system tailored to the company's needs. The research is led by two research questions:

R1: Would using ERP be beneficial for a small enterprise in the mobile housing manufacturing industry?

R2: When should mobile housing manufacturers implement an ERP system?

### **LITERATURE REVIEW**

An ERP system is a software used by organizations to integrate functions in diverse departments, such as accounting, supply chain management, risk management, project management, and human resources. By collecting transactional shared data, ERP systems enable dataflow between business departments to facilitate information sharing. As a consequence, an ERP system can prevent data duplication and provide business's data from a single source [1, p. 245].

According to Aremu et al. [1, pp. 246-248], an ERP system can give a business a competitive advantage, since it enhances decision making while reducing operational time and cost. The two main factors when analyzing the potential benefits of ERP adoption are organizational structure and technological change. When examining organizational structure; the size, financial capabilities, and policies and procedures of an organization, as well as their employee's commitment are measured.

The study suggests that in order to adopt ERP successfully and increase the organization's performance, a strong technological infrastructure, consisting of hardware, software, and internet

facilities is necessary. Furthermore, the organization needs to have a clear structure with strong management support and high levels of communication [1, p. 252].

This is also supported by research from Johansson and Sudzina, who claim that the main ones for most companies are money and time. According to their research, organizations with a formal IT structure strategy spent less money on ERP than those without a formal IT structure. They conclude that a formal IT structure helps to determine a company's specific needs when implementing ERP, which helps to control budgeting [5, p. 232].

The implementation of ERP in the mobile housing manufacturing industry is similar to the implementation in construction manufacturing. According to Tambovcecs [8, p. 69], who conducted a case study on ERP system implementation in a construction manufacturing company in Latvia, companies in construction manufacturing that use generic ERP systems oftentimes need to customize them, which requires additional investments, time, and efforts. Since project-based construction supply chains are unpredictable and unstable, they are usually not the target market for generic ERPs that rely on a stable supply chain, but rather for more adaptive ERP systems.

There are different ERP systems available for different industries. Large companies require large ERP systems, such as SAP, Oracle, People-Soft, and JD Edwards. Medium-sized companies require medium-sized ERP systems. Examples of these are QAD, Microsoft's Navision, and iScale. Smaller systems are low cost and simplified, and usually used by smaller businesses [8, p. 70].

Benefits of ERP systems for construction companies in particular are improved responsiveness in relation to customers, organizational flexibility, decision-making capabilities, shortened project completion, and strong supply chain partners. When implementing ERP in the construction industry, the high fragmentation and frequency of different projects, and specialized segments requiring specialized systems, need to be considered. In order to comply with these factors, an ERP implementation in a construction-oriented company might require non-standard and company-specific features [8, p.71].

When looking at the industrialized housing industry in particular, research conducted by Bergström and Stehn [2, p. 831] suggests that the ERP approach can have potential in this industry. It mentions, however, that even though ERP systems are proven to increase a company's efficiency, the implementation thereof can be an obstacle.

The article examines the specifics of the housing industry, which has elements of standardization as well as customization, that are different from the general manufacturing industry. It acknowledges the need for customization, as well as the potential of prefabrication and an efficiently managed supply chain in the housing industry. Furthermore, the research explains that the main interest of the housing industry is process orientation, customer-focused production, and information management. ERP aims to serve all of these interests [2, pp. 832-833].

WHS is similar to the industry examined in Bergström and Stehn's research. The companies in the housing industry examined in the research, like WHS, own and perform the design as well as the production process and possess factory buildings with industrial machinery.

The companies surveyed in the study claim various reasons for ERP implementation. The primary reason was improved materials management, followed by improved purchasing processes, and a better process overview. The research points out that companies that have not changed their characteristics, customization approach, product, and production method for a longer time period, have a hard time improving in those areas. Therefore, a business process improvement, like implementing ERP is necessary for those companies to develop [2, p. 834].

The research concludes that ERP is not necessary for industrialized housing companies. However, it points out that applying ERP can lead to more efficient and flexible operations. Furthermore, it shows that companies with less complex production processes use ERP. Companies with a more complex production increase information processing capability by decreasing information needed or increasing information processing capability [2, p. 837].

## **THEORETICAL BASIS AND METHODOLOGY**

### **Theoretical Basis**

Theories that examine requirements for successful ERP implementation build the basis for this research. According to Muscatello and Chen [6], an ERP system needs to be strategically integrated into the supply chain of a business in order to deliver optimal results. To determine the influence of the ERP system on the business' growth, strategic goals need to exist before the implementation. Additionally, executives and managers need to understand that ERP implementation is a lengthy process that requires patience. The degree of changes an ERP system brings with it is larger than that of other software and managers need to be comfortable with changing the company's way of making business by implementing ERP [6, pp. 64-66].

Furthermore, research shows that designated teams are necessary for ERP implementation. Those teams can be in-house IT specialists or consultants that accompany the implementation process and train the employees on how to use the software properly. This requires a mission statement that allows for flexibility in the process while achieving a clear goal. Throughout the implementation process, communication and support is crucial so that employees do not get frustrated with the new system but learn to use it efficiently [6, p. 66].

### **Methodology**

To determine, whether SMEs in the mobile housing manufacturing industry should implement ERP, this study examines the practice of a small company in the mobile housing manufacturing industry that does not use an ERP system yet. An on-site inspection of current processes, as well as interviews with operations managers and the CEO are used to create an overview of the present challenges the company is facing. This sets the basis to determine whether ERP would contribute to solving these challenges.

## **APPLICATION CASE**

The company for this case study is World Housing Solution (WHS), a small company located in Sanford, Florida that focus on manufacturing lightweight, modular, high-efficiency structures

that can be put together as a house by just four people. These structures can be taken down and reassembled elsewhere and have a long lifetime. They are mainly used for military housing overseas, which is why they need to be quickly deployable and ready to be assembled aiming to provide critical shelter instantly. Therefore, logistics, including shipping and packaging, is a major part of the company's operations. Furthermore, WHS offers clinics on wheels, tent platforms, water filtration and purification systems, as well as solutions for their clients' requests on an individual basis. Consequently, flexibility and innovation are crucial for the design and manufacturing process.

When it comes to the manufacturing process at the WHS manufacturing site, WHS employs part-time workers that are recruited as offers are processed, depending on how many employees are needed. There are between 15 and 50 employees working at the company at any given time, further adding to fluctuations in processes, which require a flexible system. This needs to be kept in mind when considering different ERP systems for the company.

### **Partners**

All design and manufacturing processes for the company take place in a single office point of contact, WHS' company headquarters, in Florida. Management, production, and customer support take place under one roof, which is why comprehensive vertical integration is centrally located for a quick response. Most materials are sourced from local suppliers in Florida. However, other partners and suppliers are US-based businesses with locations in Mississippi, Oklahoma, and the Carolinas. A supplier in Mississippi provides the company with the raw material used for their panels of which the housing walls consist. Fiber glass panels for housing walls are provided by their supplier in Oklahoma, who also makes the skin material that is put on the panels for isolation.

### **Process**

The process, as shown in Figure 1, starts with a sales lead, a customer who specifies his or her needs for a readily deployable housing structure. Based on the customer's request, WHS creates a proposal document that includes the designs, technology, costs, and pricing for the project. Then, WHS sends the proposal to the customer. In the past, customer responding times have varied between two weeks and two years, making this an uncertain step in the manufacturing process.

If the customer accepts the proposal, he or she can add items to the mobile housing structure, such as extra walls or windows. Once the proposal document is finalized, WHS elaborates on the design in more detail and starts the project. WHS begins by ordering the raw material for the panels that later make up the walls of the housing structure. The delivery for these panels usually takes between 30 to 45 days.

At the same time, WHS begins the staffing process. Every time they accept a proposal, they need to hire new part-time workers. Once they are hired through third-party staffing companies, they are trained on-site in the WHS headquarters for two weeks. Therefore, the newly trained employees are ready to work on the raw materials when they arrive.

WHS orders 10% more of all materials needed for their housing structures. This is because throughout the manufacturing process items can break or be cut in wrong ways. If WHS does not use the 10% extra material that they ordered, they store it in their manufacturing hall. However, it is also possible that throughout the manufacturing process more than what is available breaks. Then, WHS needs to order new panels, for example, delaying the project by the delivery time for these panels (usually four to six weeks).

After the raw materials arrive at the company's headquarters, the employees cut doors into the panels and trim the edges with metal. Then, they spray paint the structure with gator field paint in a designated area. Before shipping the housing structure, every house is built on site before being packaged (see appendix, photo 1). This ensures that all panels fit in with one another and that special items such as toilets and lights are in the right place. If additional items are requested, such as water purification systems, the company orders these items from its partners and adds them to the shipment.

Once all materials for one shipment are put together, the company packages them in containers, up to 20 for one housing structure, and ships them to destinations all around the world. Packaging is an integral part of the process as in the past this has been a segment in the process where most damages occur. WHS informs the client once the product has reached its destination and sends a team of its engineers to install the product as well as train the client on site (see appendix, photo 2).

**FIGURE 1**

**Process Flow Chart**

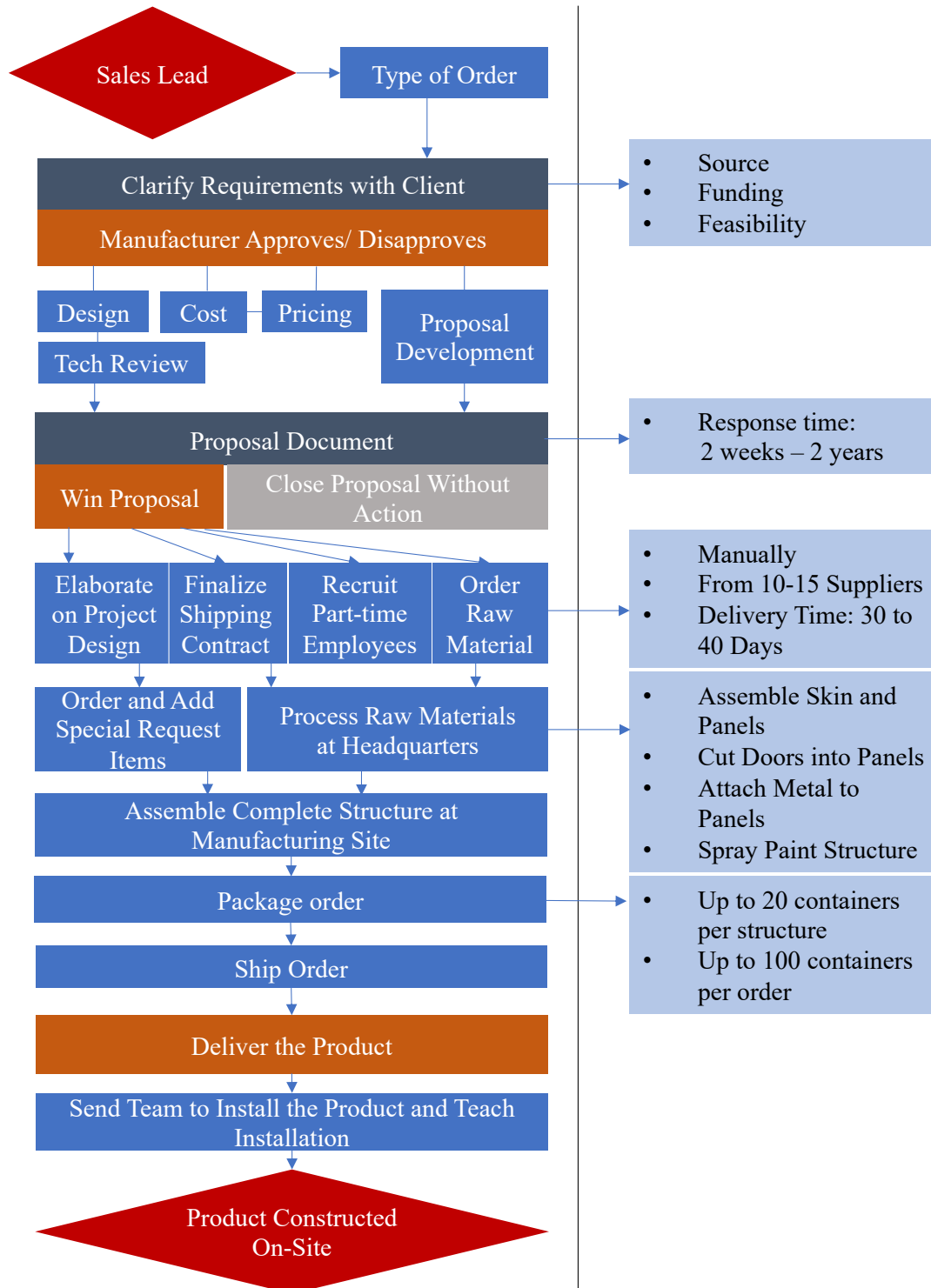

## Challenges

One challenge that the company is facing is that is driven with an entrepreneurial mindset that stems from the fact that in its beginning stages, WHS had to win as many proposals as possible, even if that meant coming up with new structures that no one had designed and built before. When this happens, the engineers would have limited time to come up with a concept for this new project to ensure timely delivery. Now that WHS has established its position in the market, one of the company's goals is aiming to incorporate more efficient organizational mindset in its operations. This means standardizing more processes and have a basic structure as a reference for every new project WHS accepts.

When talking to the Operation Manager of WHS, he mentioned that having a steady inventory would be beneficial for WHS since projects can be time sensitive and having inventory of material would ensure a timelier delivery. Currently, WHS has three housing structures in their inventory that are ready to ship immediately. Other than those structures, they also hold the 10% extra materials from previous projects in their manufacturing hall that are counted by hand by the supply and logistics manager. The reason behind not having a steady inventory yet is that all projects are customized and therefore need specific materials.

Another challenge that WHS faces is vendor management. Because they provide very detailed proposal documents, they request offers from vendors frequently. However, since only few of these proposals end up being developed, WHS rarely follows through with the offers they requested from vendors. Consequently, they have trouble establishing long-lasting vendor relationships.

## ERP Implementation

Because WHS aims to shift away from the entrepreneurial mindset to an organizational mindset and structure, an ERP system could be beneficial for their organization. So far, all processes are documented by hand and all orders are prepared individually for every project. The VP of Operations said that when three projects are going on at the same time, documentation can be hard to manage. Therefore, an automated solution would help streamline processes and improve efficiency.

An ERP system can coordinate a business's work flows, allowing automation and integration of different business processes [3]. An ERP module can include supply chain management, manufacturing, and customer relationship management, three functions that are crucial to WHS. The application ideally would integrate sales order processing, inventory and supplier management, as well as scheduling, capacity planning, sales prospecting, and customer management [3]. All these functions are currently controlled by hand at WHS, showing that an ERP system would be helpful in all aspects of the business.

The first thing to consider when choosing an ERP system is whether to use a cloud-based or a traditional ERP system. Since WHS works closely with the US military, data safety is one of their main concerns. Therefore, a cloud system cannot be taken into consideration.

WHS will need a traditional, on-premise ERP system. There are several existing ERP systems available for small manufacturing companies. Before choosing among those, it is important to identify WHS' primary needs for the ERP system. When looking at the workflow chart and examining the current processes at WHS, it becomes apparent that inventory control is one of the main aspects that is currently done by hand but could be done much faster by a software. Therefore, the chosen ERP needs to have an inventory control component. Furthermore, it would be beneficial to include Human Resources into the system since hiring new workers for every project by hand is timely. Another important aspect is customer management. So far, WHS has trouble communicating with their customers. Since the customer is often a military branch with consistently switching officers, the person of contact changes. Thus, a system that includes customer relationship management would be beneficial.

One system that combines all of these interests is the "SAP Business One" ERP System. Since SAP is one of the largest software providers in the world, customer support is available at all times. Furthermore, this system is one of the few available ERP systems that is feasible without a cloud [7].

The SAP Business One provides sales and customer management, financial management, purchasing and inventory control, analytics and reporting, industry solutions, and mobility modules for its user. The inventory control system, which will be the most important module for WHS, manages receipts, invoices, reports, and payments. Furthermore, it has a warehouse integration function that allows the user to overlook his or her inventory in real-time. This would help WHS to have a steady inventory. Another benefit that the system has is that it is equipped with industry-specific capabilities. Manufacturing is one of the industries that it can be tailored to, the specialization that WHS would be using. It is set up to minimize supply chain costs and cycle times [7].

When it comes to sales and customer management, the software is very helpful because it tracks leads throughout the sales cycle. This is important for WHS as they simultaneously work on multiple sales leads, which they prepare proposals for. It often takes a long time winning the proposal and starting with production. The ERP system would give them an overview of all the sales leads that they have prepared and what stage in the sales cycle those are at [7].

Finally, the financial management aspect of the software is important because it lists accounts payable and receivable, bank statements, and fixed asset management. Since all departments will be intertwined in the system, the financial management will directly be linked to the inventory management and sales functions, keeping track of all business functions simultaneously [7].

Another benefit of the SAP Business One ERP system is that it is an on-premise system, allowing it to conform to the security standards WHS has set for themselves. Furthermore, it has customization options that require no IT support. Since it is one of the most widely used ERP systems, it has the opportunity for over 500 add-ons from SAP partners. This contributes to the customization aspect WHS needs for their ERP system [7].

In order to implement the SAP Business One software, WHS will need to cooperate with one of their partners in Florida that will help them implement the software and train the employees. Overall, the cost of the software is around 3,500\$ per user per month [4]. For WHS, where there



are 5 employees in operations, finances, and HR, who would need access to the product, this would mean costs of 17,500\$ per month.

### CONCLUSION

When looking at WHS and how they operate at the moment, it becomes evident that an ERP system for this cost would currently not be a financially beneficial solution. Since projects come in irregularly and there are times when no project is being worked on, the costs of an ERP system would not outweigh the benefits. However, WHS is constantly growing. Currently, the company is working on becoming an official contractor for the US military. As a consequence, it would be easier for the US military to set orders and WHS would receive more projects. Therefore, if this deal goes through, WHS will need to find a rapid solution to deal with the number of projects they will be working on at a time. This is why they need to have a potential ERP system in mind that they will be ready to implement when a constant flow of projects is given.

As the company's products are engineered to individual needs, customization plays the main role when it comes to determining an ERP system. Because WHS' main customers are first responder industries, such as warfighters, disaster responders, and medical professionals, security is an important part when choosing an ERP system, allowing only on-premise solutions to be considered. The SAP Business One ERP system is one system that will fulfill WHS' needs. However, its high cost stand in the way of its immediate implementation. Nevertheless, WHS needs to automate their processes eventually, making this a solution when the flow of projects is constant and the finances and operations are more stable.

### APPENDIX



*Photo 1:* A readily deployable shelter being constructed at the WHS manufacturing site [9].



Photo 2: A readily deployable shelter, assembled at the customer's site [9].

## REFERENCES

- [1] Aremu, A., Shahzad, A., & Hassan, S. (2018). Determinants of enterprise resource planning adoption on organizations' performance among medium enterprises. *LogForum*, 14(2), 245–255.
- [2] Bergström, M., & Stehn, L. (2005). Benefits and disadvantages of ERP in industrialised timber frame housing in Sweden. *Construction Management and Economics*, 23(8), 831–838.
- [3] Heizer, J., Render, B., & Munson, C. (2017). Principles of operations management: sustainability and supply chain management. Pearson Education Limited.
- [4] How Much Does SAP Business One Cost? (2019). Retrieved from <https://www.clientsfirst-us.com/erp/sap-business-one-pricing/>
- [5] Johansson, B., & Sudzina, F. (2009). Actual vs. planned ERP systems implementation costs in European SMEs. *Proceedings of the European Conference on Information Management and Evaluation*, 232-238.
- [6] Muscatello, J. R., & Chen, I. J. (2008). Enterprise resource planning (ERP) implementations. *International Journal of Enterprise Information Systems*, 4(1), 63–83.
- [7] SAP Business One: ERP Software for Small Businesses. (n.d.). Retrieved from <https://www.sap.com/products/business-one.html#product-overview>
- [8] Tambovcevs, A. (2012). ERP system implementation in Latvian manufacturing and construction company. *Technological and Economic Development of Economy*, 18(1), 67–83.
- [9] World Housing Solution (2019). Retrieved from <https://www.worldhousingsolution.com>

## INFORMATION SHARING FOR SUPPLIER INTEGRATION: AN EMPIRICAL STUDY

Osam Sato, Tokyo Keizai University, 1-7-34 Minami-chou, Kokubunji-shi, Tokyo 185-8502  
Japan, (+81) 423-28-7934, [osamsato@tku.ac.jp](mailto:osamsato@tku.ac.jp)

Yoshiki Matsui, Open University of Japan, Graduate School of International Social Sciences,  
Yokohama National University, 79-4 Tokiwadai, Hodogaya-Ku, Yokohama-shi, Kanagawa  
240-8501, Japan, +81-45-339-3734, [ymatsui@ynu.ac.jp](mailto:ymatsui@ynu.ac.jp)

### ABSTRACT

The importance of supply chain management (SCM) is increasing in Industry 4.0 era to adapt competition in the industry. Supply chain integration (SCI) is the key to realize effective SCM and improve supply chain performance (SCP). Effective SCI improves competitiveness. SCI is one of the key SCM practices. Also, information sharing is one of the most critical elements of SCM. Supply chain information sharing (SCIS) with suppliers (ISS) is a critical antecedent of SCI and SCM (Chen et al., 2019). Past researches claim that intra-organizational coordination is antecedent of external coordination and SCI, and information sharing by suppliers is necessary to realize supplier integration. Plants share Information with suppliers that include many aspects such as delivery, demand change, inventory, schedule, quality, and more. The purchase department must be able to access this information.

On the base of the above inference and past research results, we conducted an empirical study with data in hand to confirm the above scenario. We employ version 4 dataset of the High-Performance Manufacturing (HPM) project and apply it to structural equation modeling (SEM). This study reports the result.

The contributions of this study are as follows. First, although internal (intra-) coordination is an antecedent of inter-organizational (external) coordination for SCM, the process between these two constructs has not known or studied before. This study reveals the process. Second, the process is an information-sharing process of both internal (intra-) and inter-organization. Also, they must be both IT and non-IT processes. This information must contribute to inter-organizational coordination. Our model includes these paths, reveal a significant relationship, and satisfy good model fitness.

This is an abstract only submission to SEDSI February 2020

**TITLE**

Investigating the impact of increased consumer shipping on the hospital supply chain

**ABSTRACT**

This research addresses the impact of increased e-commerce and direct to consumer shipping on the availability of carriers and their ability to provide timely and dependable deliveries to hospitals. The hospital supply chain has been significantly impacted by the increase in e-commerce packages shipped via common carrier (e.g. USPS, UPS, FEDex and DHL). This is caused by a bloat of packages in the system. This impact has caused delays so impactful that they can force surgeries to be canceled and patient care to be negatively affected. This research helps to define the issue, its root causes and possible solutions. Delays in shipping hospital supplies affects the hospitals' ability to get timely deliveries of everyday items and items that are critical such as biological items needed for surgeries and treatments for patients. Ultimately, these delays affect patients, hospital costs and has even increased costs to health insurance causing ripple effects for the entire economy. There are opportunities for common carriers and logistics companies to provide services directed to hospitals however, to date, their costs are a barrier to their utilization. Research is required in this arena to help hospitals and carriers to understand the issues and work together toward solutions. This research has begun through interviews with hospital administrators and via meeting with Association of Health Care Resource and Materials Management Professionals (AHRMM) and the South Carolina Society of Hospital Materials Management (SCSHMM). These interviews have provided information that can be used to create and utilize a survey that can be sent to hospital materials management professionals to help understand the issue, its impact and possible solutions. Executives that represent the carriers or have experience working with the referenced parcel carriers will also be interviewed to further this research. This research is funded by a research grant from the Council of Supply Chain Management Professionals (CSCMP).

**AUTHORS**

Dr. Kimberly Whitehead, Assistant Professor of Management, Anderson University, Anderson, SC  
Dr. John Frazier, Professor of Management, Anderson University, Anderson, SC

## **INVESTIGATION OF THE SUPPLIER SELECTION CRITERIA IN PERFORMANCE-BASED LOGISTICS CONTRACTS**

### **ABSTRACT**

Performance-based logistics (PBL) is a support strategy used to achieve measurable performance outcomes. In PBL, suppliers can increase their profit by attaining the system performance goal, while the buyers can lower the system cost with assured system availability. The dynamics of the PBL environment create an uncertain relationship of dependence to the supplier in PBL contracts. Therefore, the selection of the best providers is getting more significant for buyers. A current study aimed to explore supplier selection criteria in PBL. The goal achieved by examining of selection criteria of performance providers based on a literature review of non-PBL and PBL supplier selection criteria and examination of awarded PBL contracts in the defense industry. We found that nine selection criteria for the convenient provider for the defense industry in PBL.

### **1. INTRODUCTION**

Performance-based logistics (PBL) is buying performance outcomes instead of buying spares, repairs, tools and data [1]. PBL, which is also known as "power by the hour" in the private sector, differs from material-based contracts in that increasing system performance and lowering the life cycle cost of systems for customers [2], [3], [4]. In PBL, the contract identifies what is required such as target availability of systems, but the supplier determines how to attain this objective [3]. Not only is value added capabilities of suppliers significant in PBL to reach the performance goals, but also the reliability of suppliers is critical since customers depend on suppliers in all process of post-product support.

In PBL, responsibilities and freedom to act are transferred from customer to supplier [5]. This logistic shift from the transaction-based approach to the performance-based approach consists of some potential risks for customers. Considering customers' inability to observe suppliers' actions in PBL, because of the imperfect information, customers have to mitigate this risk in PBL. Considering risks associated with the supplier, the selection of the best supplier is become a key success criterion for effective and efficient PBL contracts [5].

Additionally, supplier selection is not only important for buyer/customer but also significant for a system integrator in PBL who integrate the upstream supplier's ability and their knowledge to create continues value which characterizes as a performance outcome showed in performance metrics [6]. The primary purpose of this study is to explore selection criteria for customers/buyers in PBL contracts.

The remainder of this paper is organized as follows. After presenting theoretical basis of this study, the literature review about non-PBL and PBL supplier selection criteria and performance metrics for the selected industry is presented in Section 3. Then, exploration of the supplier selection criteria for PBL is examined in Section 4. The paper will be concluded in Section 5 with the conclusion, limitations, and future research.

## **2. THEORETICAL BACKGROUND**

In PBL, the customer outsources the task of delivering the system's performance to the supplier [7]. This relationship between the provider (agent) and customer (principal) creates an example of the primary relationship in agency theory. In the principal-agent problem, we come across two different types of problems, a pre-contractual problem of and a post-contractual problem [8]. In the first type of agency problem, pre-contractual problem, the customer (principal) can expose to 'adverse selection' issue which is caused by 'hidden information.' In this situation, the supplier (agent) can distort his potential or ability to gain a contract [8]. In the post-contractual problem, which is caused by 'hidden action' because of imperfect information about suppliers' (agent) work, it is getting hard to detect whether the agent performs according to the principal's interest or not [8]. The customer/buyer can alleviate these problems by supplier selection, information gathering, and contract design [8]. Pre-contractual agency problem is one of the uninvestigated research areas in PBL literature that can be mitigated by supplier selection.

## **3. LITERATURE REVIEW OF SUPPLIER SELECTION CRITERIA**

### **3.1. Non-PBL Supplier Selection Criteria**

In literature, there are so many individual and integrated approaches, which are capable of handling multiple quantitative and qualitative factors, were suggested to explain the supplier selection problem. Dickson (1966) identified 23 important evaluation criteria for supplier selection in his study which is one of the most significant studies in literature [10]. Weber, Current, and Benton (1991) classified criteria from the articles between 1966-1990 that addressed the supplier selection problem [11]. According to the literature review of Weber et al. (1991) between 1966-1990, the most popular criterion used for assessing the performance of suppliers is quality, followed by delivery, price, repair service, technical capability [11]. Cheraghi et al. (2004) reviewed articles between 1996-2004 and classified 31 supplier selection criteria. Based on the literature review of Cheraghi et al. (2004) between 1996-2004 showed price, delivery, quality, production factors and capacity, technical capability as the most important factors. They found that reliability, flexibility, process improvement, consistency, product development, quality standards, the long-term relationship, professionalism, and integrity were significant new features for supplier selection [12]. Thiruchelvam and Tookey (2011) reviewed articles between 2001-2010 and classified 36 supplier selection criteria which are shown in Table 1. They found that price, delivery, quality, and service have a vital importance for most industries [13]. Most recently, Kumar and Pani (2014) investigated the importance of different supplier selection criteria. They found that product quality, delivery compliance, and price have supreme criticality importance [14]. In our study, we assessed those criteria for the exploring of the criteria for the most convenient suppliers in PBL.

Although there are a lot of studies for the supplier selection problem, there is no any research related to supplier selection problem in PBL, which is the most important criteria for the success of PBL contracts. Especially, considering metrics of PBL, such as availability, sustainability, mean time between replacements, the traditional cost-based approach cannot guarantee optimal supplier in PBL. Overall usage of supplier selection criteria and their ranking based on the frequency are presented in Table 1.

Table 1. Comparison and ranking of selection attributes

Criterion	(Dickson, 1966) (Survey)	(Weber et al., 1991) (1966-1990)	(Cheraghi et al., 2004) (1990-2001)	(Thiruchelvam and Tookey, 2011) (2001-2010)	Overall					
	Ranking	Papers	(%)	Papers	(%)	Papers	(%)	Papers	(%)	Ranking
Quality	1	40	53	31	79	37	100	108	72	3
Delivery	2	44	58	30	77	36	97	110	73	2
Performance history	3	7	9	4	10	10	27	21	14	10
Warranties and claim policies	4	0	0	0	0	5	13	5	1	17
Production facilities and capacity	5	23	30	10	26	20	54	53	36	4
Price	6	61	80	26	67	37	100	124	83	1
Technical capability	7	15	21	11	28	24	65	50	33	5
Financial position	8	7	9	7	18	17	46	31	21	7
Procedural compliance	9	2	3	2	5	0	0	4	.5	18
Communication system	10	2	3	4	4	7	19	13	1	13
Reputation and position in industry	11	8	10	1	1	8	22	17	1	11
Desire for business	12	1	1	0	0	2	1	3	.5	20
Management and organization	13	10	11	7	7	22	59	39	26	6
Operating controls	14	3	4	0	0	0	0	3	.5	21
Repair service	15	7	9	11	28	11	30	29	19	9
Attitude	16	6	8	5	13	6	16	17	11	12
Impression	17	2	15	2	5	4	11	8	.5	15
Packaging ability	18	3	4	0	0	4	11	7	.5	16
Labor relations record	19	2	3	1	3	6	16	9	.6	14
Geographical location	20	16	21	2	5	12	32	30	20	8
Amount of past business	21	1	1	0	0	2	1	3	.2	22
Training aids	22	2	3	0	0	0	0	2	.2	23
Reciprocal arrangements	23	2	3	2	5	0	0	4	.3	19

### 3.2. PBL Supplier Selection Criteria

The only resource that consists of supplier selection criteria for PBL implementation is Performance Based Logistics (PBL) Guidebook [15]. According to PBL Guide Book (2014) supplier aptitude can be measured by criteria such as capacity, capability, efficiency, and risk. Key considerations of these criteria are: Capacity is the availability of resources to perform a sustainment activity. The capability is the ability and skill to conduct a sustainment activity. Efficiency is the cost of the supplier to provide a performance respective to the industry standards and other alternatives. The risk is the potential of the provider to be unsuccessful while conducting a sustainment activity [15].

### 4. EXPLORING SUPPLIER SELECTION CRITERIA IN PBL

Different from the traditional business model which depend on the selling of spare parts and repairs, performance-based business model focus on buying performance outcomes [4]. PBL can increase the readiness and efficiency of the systems and reduce the cost of the lifecycle systems through well-designed supplier network [16]. This performance-based strategy creates a new environment and a new way of thinking for providers for the post-production support of complex systems whose operation and support costs exceed their production and upfront design cost [17]. In this new incentive structure of PBL model, the supplier can boost their profitability by creating new solutions for the existing problems by investment and innovation to reduce the overall costs [18]. This performance-based post-product support needs co-creation of value between customer, system integrator and suppliers. To improve system affordability with the high availability rates rely on the integration of all providers abilities and knowledge with the customer's preferences [6]. This cost efficient solutions closely related with suppliers ability to create innovative solutions based on their knowledge and skills. Because of this new dynamics of the performance-based approach, customers and main performance provider should have to assess suppliers based on their knowledge, skills, and capacities to find new solutions. We categorized criteria of providers for PBL arrangements under four categories - capacity, capability, management and organizations, efficiency – which is shown in Table 2.

Table 2. Supplier Selection Criteria

Criteria	Sub-criteria
<b>Capacity</b> (C <sub>1</sub> )	Technological Capacity (C <sub>11</sub> )
	Financial Capacity (C <sub>12</sub> )
	Service Capability and Capacity (C <sub>13</sub> )
<b>Capability</b> (C <sub>2</sub> )	Technical Capability (C <sub>21</sub> )
	Reputation and Position in Industry (C <sub>22</sub> )
<b>Management and Organizations</b> (C <sub>3</sub> )	Supply Chain Management (SCM) (C <sub>31</sub> )
	Product and Quality Management (PQM) (C <sub>32</sub> )
<b>Efficiency</b> (C <sub>4</sub> )	Contract Costs (C <sub>41</sub> )
	Geographical Location (C <sub>42</sub> )



In the performance-based logistic approach, how to achieve the performance metrics with less cost depends on the supplier's decisions. Suppliers in PBL, different from the non-PBL suppliers, they are not only focused on facilitating the efficiency of logistics processes, but also work to improve the reliability of systems. Reliability growth of the systems will reduce demand for spare parts and repairs which increase the readiness of the systems and reduce lifecycle of the systems in long-term [19], [20]. To increase reliability growth of the systems needs participants who have a high technological capacity to facilitate engineering requirements of the systems and financial capacity to make the upfront investment. System availability, which is the major performance metric in PBL, can be improved by increasing the mean-time-between-failures (MTBF) through redesign of the systems/subsystems or components that require engineering activities. Considering complex systems which are widely applicable in PBL, making reliability improvements and testing their long-term impacts on availability rates need technological capacity and technical capability. Because of these engineering activities, the selection of the supplier who has a comprehensive system knowledge is critical for the decision of trade-off between redesign and spare parts. Financial capacity is significant in PBL to make long-term investments to increase the reliability of the systems/subsystems. Upfront investments for reliability improvements for complex systems need high financial resources. These investments can be absorbed in a long-term contract. Additionally, for the short-term or middle term contracts in PBL, to make logistic process enhancements also needs financial capacity. Service capacity of suppliers in PBL is significant in PBL to decrease Mean time to repair (MTTR) that is closely related to the readiness of systems to increase operational availability which is the most important metrics in PBL. Additionally, to find new solutions, which result in cost efficiency and high readiness for the existing problems need experience, skills, and knowledge, These specialties can be used to create sustainable value creation and competitive advantage in a whole value chain.

Technical capability of suppliers is also important for improving logistic processes to create cost efficient solution for providing a sustainment activity and to increase the system readiness. Integration of this ability with knowledge and skills of supplier network can transform traditional sustainment activities to create new efficient activities to achieve customer's objectives that specified in PBL metrics [6]. Technical capability is getting significant for MTBF and MTTR, which are main performance metrics that related to operational availability and system readiness in PBL. Reputation and position of suppliers in the industry are important criterion to measure the ability of main performance provider's ability of leadership that integrate the upstream suppliers' objectives with the customer's and organization's goals [6]. Additionally, it is significant to lessen the risk by selecting most reliable suppliers, because of the potential for a participant in supplier network to be unsuccessful or cause harm while conducting a sustainment activity [15]. Additionally, this criterion closely related with their potential to take a risk to transform knowledge to value-added activities, such as reliability improvement, process enhancement. A risk-reward governance structure of PBL provides an entrepreneurial environment for suppliers who has a freedom to act to achieve desired outcomes [21]. Therefore, this criterion is also significant to understand suppliers entrepreneurial potential to take the decision to convert knowledge into value.

Besides capabilities and capacities of suppliers in PBL, supply chain management (SCM), product and quality management (PQM) of suppliers are significant for creating value for the end user and all stakeholders in the supply chain. The main provider of PBL who integrates upstream suppliers and whole processes have to operate SCM efficiently to attain desired outcomes for customers. A supply chain consists of partnerships which are the source of knowledge and skills to create value

propositions for the performance-based outcomes [19], [22]. The result of this proposition the most cost efficient solutions can be found with teamwork to decrease fill rate, to reduce MTTR and to increase the readiness of systems with less lifecycle cost. The incentive structure of PBL contracts able to integrate all supply network with their processes, material, and information. This integration around the same goals which is provided by performance metrics able to create innovative solutions to increase the readiness of the systems with less cost [20]. Product Quality Management (PQM) is significant to understand the product and manufacturing defects and to make product improvements to reduce maintenance, repair, and overhaul costs. Identifying early warning signals of product quality issues in the field based on data and customer complaints needs effective product quality management. PQM is getting significant to increase quality and reliability of systems which is the fundamental requirements to maximize the operational availability of the systems. Reliability improvement decreases the number of spare parts, the amount of repair transactions, and sustainment costs while increasing the system readiness and availability rates [6].

The efficiency of the suppliers can be assessed by the cost incurred for a participant to conduct a sustainment activity respective to the other alternatives and industry standards [21]. The measure for this criteria can be computed by dividing of each cost to estimated costs which based on historical data consists of operational and maintenance costs in the assessment process. Logistic footprint which is one of the performance metrics in PBL requires knowing all support elements needed to sustain a system. Because of difficulties to assess this performance metrics in the pre-contractual term, geographical location of depots and distance of repair center from the operational area can be used to evaluate suppliers' ability to attain this metric by decision makers. Additionally, it is significant for the logistic response time of the providers.

## **5. CONCLUSION, LIMITATIONS, AND FUTURE RESEARCH**

During recent years, the paradigm shift from the transaction-based approach to the performance-based approach has brought some critical issues related to suppliers. Especially, in the pre-contractual term, because of the 'adverse selection' issue of providers which is caused by 'hidden information,' the determination of convenient suppliers in PBL should be considered carefully by decision makers. While responsibilities and freedom to act are transferring from customer to supplier in PBL, this approach creates an uncertain relationship of dependence to the supplier. In this study, because of the critical importance of the selection of the best performance providers in PBL, we explored the supplier selection criteria in PBL and proposed decision support model for assessment of alternatives for decision makers. Supplier selection is not only important for customers but also a significant main provider in PBL who integrate the upstream supplier and their knowledge to create continues value which characterizes as a performance outcome showed in performance metrics. In PBL, supplier selection and evaluation criteria need to analyze based on the supplier partnerships' ability to create new solutions for the existing problems which are result in cost-efficient performance outcomes. These criteria are examined based on the literature review about non-PBL and PBL supplier selection criteria. These criteria considered based on their strength to deliver the performance metrics in the defense industry to get desired outcomes. The performance metrics, which represents outcomes in PBL, should have to explicitly define to select assessment criteria for the suppliers. Chosen of the appropriate performance metrics are significant for the selection of the best convenient supplier and alignment of the goals of the supplier to integrate their skills and knowledge [6]. Based on the PBL metrics in defense industry – operational availability, reliability, cost per unit usage, logistics footprint, logistics response time

-, we found that nine selection criteria for the convenient supplier for the defense industry in PBL. We categorized these criteria under four categories; capacity (technological capacity, financial capacity, service capability and capacity), capability (technical capability, reputation, and position in industry), management and organizations (supply chain management, product, and quality management), efficiency (contract costs, geographical location). Considering of specialties of each PBL contracts, these criteria can be investigated based on the contracts' requirements. One of the limitations of this research is the selection of criteria are only based on literature reviews. In future studies, besides literature reviews, a survey and interviews with PBL managers can be applied for the expanding this research. Furthermore, we can extend these finding by investigating the awarded PBL contracts in defense industry.

## REFERENCES

- [1] Defense Acquisition University (2005). Defense Acquisition Guidebook, accessed March 1, 2017, available at <http://akss.dau.mil/dag>.
- [2] Geary, S., & Vitasek, K. (2005). It's a war of ideas. *Aviation Week & Space Technology*, 163(17), 57.
- [3] Kim, S.H., Cohen, M.A., Netessine, S., (2007). Performance contracting in after-sales service supply chains. *Manage. Sci.* 53 (12), 1843–1858.
- [4] Kobren, B. (2009). What Performance-based logistics is and what it is not - and what it can and cannot do. *Defense Acquisition Review Journal*, 16(3), 254-267.
- [5] Sols, A. and L. H. Johannesen (2013). "The role of transition contracts in performance-based logistics initiatives." *Systems Engineering* 16(4): 453-463.
- [6] Randall, W. S., Pohlen, T. L., & Hanna, J. B. (2010). Evolving a theory of Performance-based Logistics using insights from service-dominant logic. *Journal of Business Logistics*, 31(2), 35-61.
- [7] Helander, A., & Möller, K. (2008). System supplier's roles from equipment supplier to performance provider. *Journal of Business & Industrial Marketing*, 23(8), 577-585.
- [8] Bergen, M., Dutta, S., & Walker Jr, O. C. (1992). Agency relationships in marketing: A review of the implications and applications of agency and related theories. *The Journal of Marketing*, 1-24.
- [9] Eisenhardt, K. M. (1989). Agency theory: An assessment and review. *Academy of management review*, 14(1), 57-74.
- [10] Dickson, G. W. (1996). "An analysis of vendor selection systems and decisions."
- [11] Weber, C. A., et al. (1991). "Vendor selection criteria and methods." *European Journal of Operational Research* 50(1): 2-18.
- [12] Cheraghi, S. H., et al. (2004). "Critical success factors for supplier selection: an update." *Journal of Applied Business Research (JABR)* 20(2).
- [13] Thiruchelvam, S., Tookey, J.E., (2011). Evolving trends of supplier selection criteria and methods. *Int. J. Automot. Mech. Eng.* Volume 4, 437-454.
- [14] Kumar Kar, A., & K. Pani, A. (2014). Exploring the importance of different supplier selection criteria. *Management Research Review*, 37(1), 89-105.
- [15] Department of Defense (DoD) (2014). Performance Based Logistics (PBL) Guidebook. Retrieved from <https://acc.dau.mil/psa>
- [16] Spring, B. (2010). Performance-Based Logistics: Making the Military More Efficient. Heritage Foundation Backgrounder, (2411).
- [17] Singh, P., & Sandborn, P. (2006). Obsolescence driven design refresh planning for sustainment-dominated systems. *The Engineering Economist*, 51(2), 115-139.

- [18] Hypko, P., Tilebein, M., & Gleich, R. (2010). Clarifying the concept of performance-based contracting in manufacturing industries: A research synthesis. *Journal of Service Management*, 21(5), 625-655.
- [19] Randall, W. S., Nowicki, D. R., & Hawkins, T. G. (2011). Explaining the effectiveness of performance-based logistics: a quantitative examination. *The International Journal of Logistics Management*, 22(3), 324-348.
- [20] Randall, W. S., Hawkins, T. G., Haynie, J. J., Nowicki, D. R., Armenakis, A. A., & Geary, S. R. (2015). Performance-Based Logistics and Interfirm Team Processes: An Empirical Investigation. *Journal of Business Logistics*, 36(2), 212-230.
- [21] Randall, W. S., Nowicki, D. R., Deshpande, G., & F. Lusch, R. (2014). Converting knowledge into value: gaining insights from service-dominant logic and neuroeconomics. *International Journal of Physical Distribution & Logistics Management*, 44(8/9), 655-670.
- [22] Vargo, S. L., & Lusch, R. F. (2004). Evolving to a new dominant logic for marketing. *Journal of marketing*, 68(1), 1-17.

**THE IMPACT OF COUNTERFEIT RISK MANAGEMENT ON SUPPLY CHAIN  
PERFORMANCE IN THE HEALTHCARE SECTOR:  
A PRELIMINARY EMPIRICAL ANALYSIS**

Mauro Falasca, Department of Marketing and Supply Chain Management, College of Business,  
East Carolina University, Greenville, NC 27858, 252-328-9871, falascam@ecu.edu

Scott A. Dellana, Department of Marketing and Supply Chain Management, College of Business,  
East Carolina University, Greenville, NC 27858, 252-328-4893, dellanas@ecu.edu

John F. Kros, Department of Marketing and Supply Chain Management, College of Business,  
East Carolina University, Greenville, NC 27858, 252-328-6364, krosj@ecu.edu

William J. Rowe, Department of Marketing and Supply Chain Management, College of  
Business, East Carolina University, Greenville, NC 27858, 252-737-4342, rowew@ecu.edu

**ABSTRACT**

The purpose of this paper is to develop and test a model that explores the relationships among supply chain (SC) counterfeit risk management and supply chain performance in the healthcare sector. In the proposed theoretical model, SC counterfeit risk management is characterized by factors of healthcare SC counterfeit risk orientation, healthcare SC counterfeit risk mitigation and healthcare SC risk management integration, while supply chain performance is represented by healthcare logistics performance and healthcare organization overall performance. Structural equation modeling and survey data from 44 health care supply chain managers are used to test the research hypotheses. Healthcare SC counterfeit risk orientation was found to have a significant direct positive effect on healthcare SC counterfeit risk mitigation. Healthcare SC risk counterfeit risk mitigation had a significant direct positive effect on healthcare SC risk management integration. With respect to healthcare logistics performance, healthcare SC counterfeit risk mitigation had an insignificant direct positive effect, while healthcare SC risk management integration was found to have a significant direct positive effect. Finally, healthcare logistics performance had a significant direct positive effect on healthcare organization overall performance. Preliminary empirical results thus confirm the critical mediating role of SC counterfeit risk management integration in the healthcare sector. The study findings provide a relevant foundation for further research and practice in a current and relevant healthcare supply chain management topic.

**KEYWORDS:** Empirical studies, healthcare supply chain management, risk management, supply chain performance

## INTRODUCTION

As global supply chains grow increasingly complex, risk management and the development of risk mitigation strategies continues to be a top priority among supply chain scholars and practitioners [1, 2]. Unexpected events that pose a risk to the supply chain are well-known: natural disaster, economic shifts, government policy, etc. Although counterfeiting is a less obvious risk by its very nature (secretive and intentionally hidden), it is no less nefarious and harmful in its impact on the supply chain. Specifically, healthcare is an industry at the forefront of facing the critical challenge of identifying and managing counterfeit risk [3], especially considering the frequency of mislabeled and adulterated pharmaceuticals and defective medical devices [4]. Counterfeit risk across the healthcare supply chain (HCSC) presents a potential impact on suppliers, healthcare providers, and patients. Extending even beyond the legal and reputational risks posed by counterfeiting, when counterfeit goods infiltrate the HCSC it can lead to inferior products having a severe impact on patient outcomes [5, 6]. Recognizing the significance of this issue, the purpose of our study is to examine how organizations in the healthcare sector approach risk management in relation to counterfeit risk in the HCSC.

Considering the importance of healthcare delivery and the emphasis on patient outcomes, supply chain managers are tasked with preventing counterfeit goods from entering the HCSC. This challenge becomes greater as the prevalence of counterfeiting grows and counterfeiters become more adept at manufacturing goods which appear to be authentic pharmaceutical drugs or medical devices that are nearly indistinguishable from the original product. From the perspective of drug and medical suppliers, the occurrence of counterfeiting can lead to damaged business relationships and expensive recalls [7]. Even still, the HCSC literature currently lacks understanding of the interplay among risk management, counterfeit risk, and performance of the healthcare organization. Our study seeks to shed light on these important areas of healthcare service delivery.

Advancing current HCSC research, our study considers the relationships between supply chain counterfeit risk management and supply chain performance in the healthcare sector. More precisely, regarding risk, we focus on the factors of healthcare supply chain counterfeit risk orientation, healthcare counterfeit risk mitigation, and healthcare risk management integration. Regarding performance, we focus on healthcare logistics performance and overall performance of the healthcare organization. Taken together, these different constructs provide the foundation for a theoretical model and hypotheses which are tested using responses from 44 supply chain practitioners in the healthcare sector.

Next, we review background literature on supply chain risk and counterfeiting, propose our model, put forth a set of hypotheses, detail our methodology, and present the findings of our study. Finally, we offer implications with relevance for those with an interest in both theory and practice in the healthcare sector.

## **BACKGROUND LITERATURE AND THEORETICAL FRAMEWORK**

Supply chain disruptions are varied and costly when they occur [8]. Supply chain risks studied in the literature have encompassed: environmental, financial, information, intellectual property, reputational, process and technology, logistics, supply and demand risks [9-18]. With the integration of economies globally and the expansion of supply chains, the opportunities for supply chain disruptions continue to increase, especially in relation to counterfeiting [19]. Consequently, interest in the impact and mitigation of risks in the supply chain has seen substantial growth in the research literature [2, 20]. Of these risks, counterfeiting is unique because, in its criminal nature, it actively undermines fair commerce while disregarding the potential for injury to many consumers.

### **Overview of Risk and Counterfeiting in the Supply Chain**

Many researchers have studied supply chain risk and developed classifications that help guide risk identification and mitigation strategies. Ho, Zheng [2] proposed the classification of a supply chain risk into one of two main categories. The first group includes macro risks, rare negative external events. A macro risk can be either natural (e.g., a tornado) or man-made (e.g., an act of terrorism). The second category includes micro risks, which result from continuing internal supply chain activities. This type of risk is usually related to supply, manufacturing, infrastructure, or demand and relates to events that can disrupt supply chain functions. Kwak, Rodrigues [21] build on this classification in their research. They view risk events as occurring on four levels that may interact. For example, a low-level risk event can increase the impact of a top-level risk event, where a top-level disruptive event can negatively impact time, cost and quality. Therefore, risk events should not be viewed in isolation, but interaction effects should be considered.

Counterfeiting has been characterized a variety of ways in the research literature. Berman [22] classified counterfeited products into four groups. These include reverse engineered products that pose as the original, complete fakes produced by illegitimate manufacturers (i.e., knockoffs), third shift legitimate excess product that is produced outside of legitimate contracts, and non-conforming original product that is not labeled as such. Berman [22] also addresses the gray market that trades products through channels that are not intended by the original manufacturer. D'Amato and Papadimitriou [5] describe counterfeiting by varying degrees of interaction between legitimate and illegitimate supply chains. They proposed the LISC (Legitimate-Illegitimate Supply Chain) model that catalogues six types of supply chain counterfeiting risks. These risks include counterfeits from an illegitimate retailer, infiltration with counterfeits by a legitimate retailer, legitimate goods from an illegitimate retailer, extra product sold by a retailer (legitimate or illegitimate), retail service copycatting, and shoplifting where items are resold.

When it comes to counterfeit risk, laws regarding truth in labeling have been in effect for many decades to protect consumers from false advertising and fake products [23]. However, it was not until 1984 that international counterfeiting was specifically addressed in the Trademark Counterfeiting Act passed by the U.S. Congress. Bush, Bloch [24] report that there was a shift at that time from counterfeiting of high-end consumer products to lower end products.

### **Counterfeiting risk, detection and mitigation in the supply chain**

The practitioner and research literatures abound with ways to detect and mitigate counterfeiting in the supply chain. Modern counterfeiting research dates back to the 1980's when the practice of counterfeiting expanded globally to include a wide variety of products. In the early days, it was left to the organization to figure out how to mitigate counterfeiting. This spurred interest and development of product tracking technologies. Bush, Bloch [24] recommended supply chains add unique identifiers to products. They also suggested actively informing the public of counterfeit episodes and rewarding forward channel members that cooperate to mitigate counterfeiting infiltrations. Shultz and Saporito [25] offered advice on mitigating brand piracy. They suggested using high-tech product labeling, improving brand marketing and counterfeit surveillance, increasing the pace of product innovation, and potentially buying out the offending organizations. Hoecht and Trott [26] identified different anti-counterfeiting strategies in the literature, including forming industry coalitions, using internal/external guanxi, or even withdrawing from high-risk markets.

Within the past decade, there has been a push to increase the use of authentication and tracking technologies to detect and deter counterfeiting, especially in the pharmaceutical and healthcare industries. However, tracking technologies come with their own challenges. For example, the effective use of tracking technologies requires strong collaborative relationships among supply chain partners (Basole and Nowak [27]).

### **The Healthcare Supply Chain**

The HCSC can be viewed as a value chain involving producers, purchasers, providers, fiscal intermediaries and payers [28]. Respective examples of each include drug manufacturers, purchasing organizations, hospitals, insurers, and individuals. The HCSC involves all the usual supply chain issues related to sourcing, operations, logistics, customer relations, flow of information (which is complicated by privacy laws), and financial transactions through the supply chain [29, 30]. Quality management and control in the supply chain is particularly important given the potential for injury to consumers from drugs, equipment, or provider error [29, 31]. Government regulatory bodies are often key stakeholders in the manufacture and distribution of drugs and equipment related to the industry [32, 33]. Further, the typical supply chain cost in the healthcare industry accounts for 38% of total costs while the corresponding cost for retail business is 5% [34]. This underscores the inherent complexity of the HCSC and its difference in many respects from a supply chain for typical commercial products such as cars and clothes [35].

The efficiency and effectiveness of healthcare supply chains has been a focus only recently in the research literature. Kim and Kwon [36] studied the literature to characterize the HCSC and related performance in the United States. They found that lack of collaboration within the HCSC represents a chief obstacle to maximizing supply chain surplus [37] Kwon et al. (2011) also assert that the HCSC members need to better share information, risks and rewards. Smith, Nachtmann [38] state that a key driver of cost and quality of healthcare delivery is the logistics process. They also report a lack of data standardization across the healthcare industry. VanVactor [39] reports that logistics preparedness is often missed when healthcare managers



prepare for mitigation of supply chain disruptions. Barriers to entry in healthcare logistics has also been cited as an obstacle to a more effective HCSC [40]. Lee, Lee [41] studied the HCSC, testing a structural equation model involving the influence of supplier cooperation, SC efficiency and quality management practice on healthcare organizational performance. They report that performance is positively associated with all three constructs. Kabbaj and Van Peteghen [42] found that supply chain tools in healthcare have been limited to strategic sourcing/contract management. They indicate that commercial supply chains typically use many more tools involving transportation, warehousing operations, supplier relationship management, 3PLs, etc.

The use of tracking technologies has been proposed as a means to reduce costs and increase efficiency in the HCSC. Technologies include Frequency Identification (RFID), Global Positioning Systems (GPS) and nanotechnology [43]. For example, Mehrjerdi [44] asserts that RFID technology can help reduce HCSC operating costs by decreasing labor costs, insurance claims, and risks associated with medical errors. GPS may be used in transportation applications involving patients and the movement of goods.

It is generally reported that the HCSC is well behind commercial supply chains in maturity and application of SC tools. Some researchers have posited that the classical approaches to supply chain management (SCM) have unique challenges in a healthcare setting. Kwon et al. (2011) state that the development stage in healthcare supply chains at that time was far behind commercial supply chain in using various supply chain tools. de Vries and Huijsman [30] acknowledge the difficulty of applying typical SCM practices in the HCSC but consider SCM in healthcare as evolving and expanding. As previously discussed, this is due in large part to the complexity of the HCSC. Chakraborty and Dobrzykowski [35] characterize the complexity dimensions in the HCSC as quality of relationship, volume and frequency of interactions in the network, number of elements, degree of differentiation among the actors in the network, and extent of interrelationships among network elements. The complexity of the HCSC and the related challenges will certainly impact on the resilience of the HSCS in the face of disruptions. In the next section we provide a brief overview of the counterfeit risk management literature as it relates to the HCSC.

### **Counterfeit Risk in the Healthcare Supply Chain**

This degree of complexity in the HCSC makes planning for and mitigation of risk more challenging than in the case of a typical commercial supply chain. Risk management in the HCSC encompasses a variety of potential disruptions. These risks of disruption range from cybersecurity threats to infiltration of counterfeit products to natural disasters [45-47]. Strategies for mitigation of potential disruptions are those found in the general literature on risk management. For counterfeiting risk, these may include the use of high-tech product labeling, improving brand marketing and counterfeit surveillance, increasing the pace of product innovation, and potentially buying out the offending organizations (Bush, Bloch [24]; Shultz and Saporito [25]). The technological solutions previously discussed can be helpful. For example, Kwok, Ting [48] report on an analyzer that uses RFID and electronic product codes (EPC) to discover counterfeit distribution sources and control counterfeit spread.

Much of the risk surrounding counterfeiting has involved pharmaceutical drugs. Starting around the year 2000, the incidence of counterfeited drugs in the US (and globally) began to rise noticeably. Part of this phenomena was the result of extending the supply chains to low-cost suppliers in developing countries [49], allowing the infiltration of counterfeits through secondary distribution channels. By the late 2000's, the US was importing about 80% of active ingredients while India and China already had more than 30% of the world's drug master files [50]. Opportunity for counterfeit infiltration came from fragmented information flows among supply chain participants [51]. This sudden rise in counterfeited pharmaceutical products prompted the realization by officials that the proliferation of fake drugs could lead to disease resistance and widespread consumer deaths. RFID was proposed in the research literature as an effective means to combat the problem [51]. However, widespread adoption has been slow, mainly due to costs [32].

A good deal of the literature on counterfeited drugs derives from the practitioner literature. This often relates to actions that governments are taking, generally in the form of regulations, to combat this growing problem. The problem is so pervasive and potentially damaging that the Council of Europe recently passed the MEDICRIME Convention, "a binding international treaty in the criminal law field on counterfeiting of medical products and similar crimes involving threats to public health" [46]. Counterfeit drugs are often sold through non-legitimate online pharmacies; but have also been found in legitimate supply chains [52]. In the U.S., drugs affected include Avastin, Viagra, Lipitor, and Alli [51]. Consequently, the Drug Quality and Security Act of 2013 was passed in the US and requires that every product be identifiable by a unique serial number in addition to the origin, shelf life and batch number for that product. Full track-and-trace capabilities are to be implemented by 2023 [33]. Hence the keen practitioner interest in means for combating counterfeit drugs.

Counterfeiting thus continues to be a substantial problem and impacts particularly hard in the healthcare sector and the related pharmaceutical industry. It impacts negatively on quality, safety, reputation, profits and supply chain performance. Integration of HCSC members for managing counterfeit risk will be crucial to properly mitigating such risks to the benefit of individual stakeholders. In the next sections we develop a model that and hypotheses that represent the relationships that are important to understanding and managing healthcare counterfeit risk in the supply chain.

### **Theoretical Framework and Hypotheses**

Based on the preceding review of the literature and the issues important to planning for and mitigating healthcare counterfeiting, we propose the model shown in Figure 1. The model suggests that an orientation toward potential counterfeiting in the HCSC precedes effective mitigation of counterfeit risk events. Further, efforts to effectively mitigate counterfeit risk events foster HCSC integration and improved healthcare logistics performance. HCSC integration also impacts positively on healthcare logistics performance. Finally, improved logistics in healthcare should result in better healthcare organization overall performance. The size of the healthcare organizations (measured in terms of yearly revenues) is included in the model as a control variable. The related hypotheses are presented and supported in the following paragraphs.

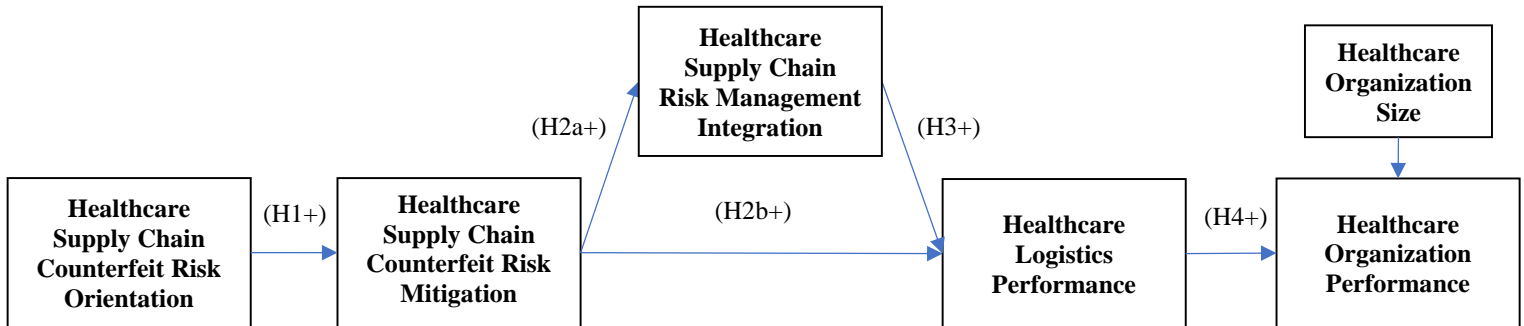
**Figure 1. Proposed theoretical model**

It stands to reason that a healthcare organization that employs risk-based thinking will be better poised to manage risk than healthcare organizations that do not actively concern themselves with potential risks. Risk orientation has been shown in the literature to be related to positive actions toward risk mitigation [53]. A higher level of alertness should translate into better mitigation of counterfeit risk in the HCSC.

- H1.** SC counterfeit risk orientation directly and positively contributes to SC counterfeit risk mitigation efforts in healthcare organizations.

Organizations that are oriented toward counterfeit risk management tend to work closely with suppliers and customers to identify counterfeits in the supply chain when they occur and to mitigate them more effectively. Organizations more focused on risk mitigation across the supply chain enjoy higher supply chain integration and more effective supply chain risk management [18]. Further, logistics performance is improved by inter-firm integration [54, 55]. The following hypotheses are therefore proposed.

- H2a.** SC counterfeit risk mitigation efforts directly and positively contribute to SC risk management integration in healthcare organizations.
- H2b.** SC counterfeit risk mitigation efforts directly and positively contribute to SC logistics performance in healthcare organizations.
- H3.** SC risk management integration directly and positively contributes to logistics performance in healthcare organizations.

Collaboration in the HCSC is also linked to an increase in the supply chain surplus [36]. Lee, Lee [41] find that supply chain efficiency, which relates to logistics, is positively associated with healthcare organizational performance. Smith, Nachtmann [38] assert that logistics is a key driver of delivery cost in healthcare. Therefore, increases in efficiency related to better supply chain logistics performance should help improve organizational performance.

- H4.** Logistics performance directly and positively contributes to overall performance in healthcare organizations.

## METHODOLOGY

### **Instrument development**

An online survey was developed to test the research hypotheses (Refer to Table 2). The survey items included in the research study tap perceptual measures of HCSC managers' opinions, which have been shown to satisfy different reliability and validity requirements in construct measurement [56].

More specifically, the healthcare supply chain counterfeit risk orientation (HCRO) and healthcare supply chain counterfeit risk mitigation (HCRM) items were adapted from measures originally included in Ambulkar, Blackhurst [57]. The healthcare supply chain risk management integration (HRMI) construct, on the other hand, was adapted from a risk management maturity measure originally developed and validated by Florio [58]. The HCRO, HCRM and HRMI constructs were measured using a seven-point Likert scale (Ranging from 1 - 'Strongly disagree' to 7 - 'Strongly agree').

The healthcare logistics performance (HLP) scale was adapted from the works of Chopra and Meindl [59] and Bozarth and Handfield [60], while healthcare organization overall performance (HOP) was measured using a series of previously validated items [61, 62] related to profit margin, return on investment (ROI), customer satisfaction and quality. All the different HLP and HOP measures were assessed in relation to the organizations' competitors and used a seven-point Likert scale (Ranging from 1 - 'Much worse than competitors' to 7 - 'Much better than competitors').

A two-step process was used to demonstrate the content and face validity of the survey. In the first step, a group of supply chain professionals evaluated the survey [63]. In the second step, a group of randomly selected contacts was used to conduct a pilot study. Feedback collected from these two steps resulted in no significant modifications to the instrument.

### **Data Collection**

The target population consisted of SCM professionals in the healthcare sector. A total of 1,741 contacts were obtained from three professional organizations: The Association for Healthcare Resource and Materials Management (AHRMM), the Council for Supply Chain Management Professionals (CSCMP), and the Institute for Supply Management (ISM).

The survey instrument was administered online, and potential participants were contacted via email. A total of 140 usable responses was collected (representing a response rate of 8 percent). Of the 140 study participants, 44 identified themselves as supply chain managers from the healthcare sector. Participation in the study was voluntary and no incentives were offered to the professionals.

### **Respondent Demographics**

An analysis of the respondent demographics is presented in Table 1. Study participants included

top-, mid-, and entry-level HCSC managers. Mid-level managers made up the majority (59%) of the study participants. Top-level HCSC managers made up 32% of the respondents, while entry-level managers represented only 7% of the participants. Annual revenue was used to characterize the size of the organizations. Small and medium healthcare organizations (i.e., organizations with a revenue level smaller than \$1 billion) represented 44% of the participants, while large healthcare organizations (i.e., organizations with a revenue level greater than or equal to \$1 billion) represented 41% of the sample.

**Table 1. Survey Demographics**

<b>Respondent Current Position</b>	<b>No.</b>
Top level healthcare supply chain manager	14
Mid-level healthcare supply chain manager	26
Entry level healthcare supply chain manager	3
Other	1
<b>Total</b>	<b>44</b>
<b>Healthcare Organization's Yearly Revenue</b>	<b>No.</b>
\$10 million or less	1
More than \$10 million to \$100 million	11
More than \$100 million to \$500 million	4
More than \$500 million to \$1 billion	4
Over \$1 billion	18
N/A	6
<b>Total</b>	<b>44</b>

### **Data Analysis and Sample Size**

Table 2 displays descriptive statistics for the different constructs and survey items. Partial least squares structural equation modeling (PLS-SEM) was used to evaluate the proposed model. PLS-SEM is a variance-based structural equation modeling approach that has been found to perform well with small sample sizes (i.e., samples with less than 100 observations) [64]. Henseler, Dijkstra [65], for example, demonstrated that, in the case of small samples, PLS-SEM has better convergence behavior than covariance-based approaches. As previously mentioned, this study is based on a sample of 44 HCSC managers. Regarding the sample size, Hair, Ringle [64] suggest that the minimum required sample size in PLS-SEM should be equal to the larger of ten times the largest number of structural paths directed at a particular construct or ten times the largest number of indicators used to measure a construct. A sample of 44 observations satisfies the minimum threshold discussed above.

**Table 2. Survey Scale Items Descriptive Statistics**

<i>Construct/Item</i>	<b>Mean</b>	<b>Std. Dev.</b>
<b><i>Healthcare Supply Chain Counterfeit Risk Orientation (HCRO)</i></b>	<b>5.438</b>	<b>1.367</b>
<b>HCRO1.</b> We feel the need to be alert for possible counterfeits in the supply chain at all times.	5.636	1.586
<b>HCRO2.</b> We recognize that the potential for counterfeiting in the supply chain is always looming.	6.000	1.398
<b>HCRO3.</b> We think a lot about how counterfeiting in our supply chain can be avoided.	4.955	1.670
<b>HCRO4.</b> Counterfeiting is an increasingly important issue in our industry.	5.159	1.446
<b><i>Healthcare Supply Chain Counterfeit Risk Mitigation (HCRM)</i></b>	<b>4.448</b>	<b>1.662</b>
<b>HCRM1.</b> We have a person or team dedicated to identifying counterfeits in the supply chain.	4.750	2.092
<b>HCRM2.</b> We have developed metrics to assess the risk of counterfeiting in the supply chain.	3.837	2.271
<b>HCRM3.</b> We have an established counterfeit management process to follow in the event counterfeiting is detected.	3.841	1.999
<b>HCRM4.</b> We coordinate with supply chain partners to identify counterfeiting.	5.364	1.416
<b><i>Healthcare Supply Chain Risk Management Integration (HRMI)</i></b>	<b>4.956</b>	<b>1.387</b>
<b>HRMI1.</b> We involve our suppliers in identification and mitigation of potential SC risks.	5.432	1.531
<b>HRMI2.</b> We encourage our suppliers to use a structured risk management process (e.g., ISO 31000).	4.273	1.730
<b>HRMI3.</b> We work with our customers to identify and mitigate potential SC risks.	5.163	1.598
<b><i>Healthcare Logistics Performance (HLP)</i></b>	<b>5.502</b>	<b>1.267</b>
Compared to our major competitors:		
<b>HLP1.</b> Our cycle time is better.	5.523	1.389
<b>HLP2.</b> Our on-time delivery is better.	5.773	1.217
<b>HLP3.</b> Our perfect order performance is better.	5.409	1.369
<b>HLP4.</b> Our inventory turns are higher.	5.302	1.650
<b><i>Healthcare Organization Overall Performance (HOP)</i></b>	<b>5.477</b>	<b>1.035</b>
Compared to our major competitors:		
<b>HOP1.</b> Our profit margin is better.	5.182	1.352
<b>HOP2.</b> Our return on investment (ROI) is better.	5.159	1.275
<b>HOP3.</b> Our customer satisfaction is better.	5.659	0.963
<b>HOP4.</b> Our quality is better.	5.909	1.158

### Item Reliability and Construct Internal Consistency, Convergent and Discriminant Validity

The assessment of the proposed model included an analysis of the reliability of the individual indicators, as well as the internal consistency, convergent validity and discriminant validity of the constructs.

First, outer loadings were evaluated to assess the reliability of the different survey items. Table 3 presents the items' outer loadings. All outer loadings were statistically significant. Furthermore, all but one survey item had loadings above the suggested cutoff of 0.70 [66]. Even though HCRM4 had a loading between 0.60 and 0.70, the item was retained since its deletion was not required to increase the reliability of the corresponding construct above the suggested minimum threshold values. Overall, the results indicate an adequate reliability level for the different individual indicators.

**Table 3. Outer Loadings**

<b>Item</b>	<b>Outer Loading</b>	<b><i>p</i></b>
HCRO1	0.937	< 0.001
HCRO2	0.910	< 0.001
HCRO3	0.932	< 0.001
HCRO4	0.788	< 0.001
HCRM1	0.881	< 0.001
HCRM2	0.918	< 0.001
HCRM3	0.913	< 0.001
HCRM4	0.630	< 0.001
HRMI1	0.900	< 0.001
HRMI2	0.809	< 0.001
HRMI3	0.856	< 0.001
HLP1	0.945	< 0.001
HLP2	0.919	< 0.001
HLP3	0.922	< 0.001
HLP4	0.825	< 0.001
HOP1	0.898	< 0.001
HOP2	0.908	< 0.001
HOP3	0.833	< 0.001
HOP4	0.836	< 0.001

The internal consistency of the latent constructs was evaluated next using Cronbach's  $\alpha$ , reliability coefficient  $\rho_A$  [67] as well as Composite Reliability estimates. Table 4 displays the different estimates. All values were above the 0.70 cut-off recommended by Hair, Hult [66], suggesting a satisfactory internal consistency level across the five constructs included in the study. Average Variance Extracted (AVE) values were used to assess convergent validity (Refer to Table 4). The AVE estimates indicate that all constructs explain more than 50 percent of the

variance of their indicators, suggesting adequate convergent validity levels across all five research constructs.

**Table 4. Construct reliability and validity**

Construct	Cronbach's $\alpha$	$\rho_A$	Composite Reliability	Average Variance Extracted (AVE)
HCRO	0.917	0.965	0.940	0.799
HCRM	0.860	0.896	0.907	0.712
HRMI	0.819	0.846	0.891	0.733
HLP	0.925	0.935	0.947	0.817
HOP	0.893	0.905	0.925	0.756

Next, the constructs' discriminant validity was assessed. Cross-loadings, the Fornell-Larcker criterion, and the heterotrait-monotrait (HTMT) ratio of correlations method were used to evaluate the constructs' discriminant validity. First, cross-loadings were examined to determine whether the constructs met the conditions for discriminant validity (See Table 5). While a few cross-loadings were relatively high (e.g., the HLP3 cross-loading on HOP), loadings on the hypothesized model constructs were higher than the loadings on the remaining constructs for each individual survey item. Cross-loadings therefore provide initial evidence to support the discriminant validity of the research constructs [66].

**Table 5. Discriminant validity: Cross-loadings**

Item	Construct				
	HCRO	HCRM	HRMI	HLP	HOP
HCRO1	<b>0.937</b>	0.576	0.491	0.203	0.291
HCRO2	<b>0.910</b>	0.587	0.475	0.370	0.434
HCRO3	<b>0.932</b>	0.716	0.447	0.244	0.349
HCRO4	<b>0.788</b>	0.327	0.231	0.020	0.069
HCRM1	0.674	<b>0.881</b>	0.452	0.232	0.362
HCRM2	0.560	<b>0.918</b>	0.525	0.286	0.395
HCRM3	0.529	<b>0.913</b>	0.523	0.262	0.319
HCRM4	0.393	<b>0.630</b>	0.289	0.097	0.166
HRMI1	0.394	0.488	<b>0.900</b>	0.573	0.578
HRMI2	0.426	0.359	<b>0.809</b>	0.384	0.511
HRMI3	0.422	0.529	<b>0.856</b>	0.349	0.610
HLP1	0.120	0.162	0.405	<b>0.945</b>	0.690
HLP2	0.304	0.294	0.432	<b>0.919</b>	0.770
HLP3	0.342	0.340	0.527	<b>0.922</b>	0.818
HLP4	0.130	0.154	0.512	<b>0.825</b>	0.556
HOP1	0.274	0.303	0.556	0.727	<b>0.898</b>
HOP2	0.249	0.344	0.685	0.797	<b>0.908</b>
HOP3	0.384	0.336	0.541	0.556	<b>0.833</b>
HOP4	0.332	0.348	0.506	0.645	<b>0.836</b>



**Note:** Primary loadings for each indicator shown in bold.

The Fornell-Larcker method [68] was used next. As displayed in Table 6, the square roots of the AVEs for each of the five research constructs was higher than the correlations of the constructs with the remaining latent variables included in the proposed model, suggesting adequate discriminant validity for all constructs.

**Table 6. Discriminant validity: Fornell-Larcker criterion**

<b>Construct</b>	HCRO	HCRM	HRMI	HLP	HOP
HCRO	<b>0.894</b>				
HCRM	0.648	<b>0.844</b>			
HRMI	0.479	0.541	<b>0.856</b>		
HLP	0.258	0.271	0.519	<b>0.904</b>	
HOP	0.348	0.381	0.662	0.793	<b>0.869</b>

**Note:** Square root of the AVE on diagonal in bold.

The Heterotrait-Monotrait (HTMT) inference method [69] was used to determine whether the HTMT values were significantly different from 1. For each combination of constructs, 95% HTMT bias-corrected confidence intervals were computed from 5,000 bootstrap samples. As shown in Table 7, none of the bootstrap confidence intervals included the value of 1. These results provide further evidence that all constructs represent valid measures of unique concepts [69].

**Table 7. Discriminant validity : Heterotrait-Monotrait (HTMT) inference criterion**

<b>Construct</b>	HCRM	HRMI	HLP	HOP
HCRO	(0.468; 0.837)	(0.220; 0.792)	(0.108; 0.435)	(0.133; 0.621)
HCRM		(0.311; 0.859)	(0.115; 0.558)	(0.159; 0.708)
HRMI			(0.305; 0.814)	(0.421; 0.962)
HLP				(0.740; 0.925)

The model was finally checked for potential collinearity issues by examining Variance Inflation Factor (VIF) values. Table 8 displays the VIF values of all combinations of exogenous (or predictor) constructs (represented by the rows) and endogenous constructs (represented by the columns). Since all the estimated VIF values were below the maximum threshold of five recommended by Hair, Hult [66], collinearity was not deemed an issue.

**Table 8. Variance Inflation Factor (VIF) values**

<b>Construct</b>	<b>HCRM</b>	<b>HRMI</b>	<b>HLP</b>	<b>HOP</b>
HCRO	1			
HCRM		1	1.414	
HRMI			1.414	
HLP				1

## RESULTS

### Hypotheses testing

The structural equation model was evaluated using SmartPLS, a PLS-SEM software package [70]. To test the research hypothesis, a bootstrap resampling method (5,000 resamples) was used to estimate the level of significance of the standardized path coefficients. Table 9 displays the results of this portion of the analysis.

**Table 9. Summary of hypotheses testing**

	<b>Path</b>	<b>St. Weight</b>	<b><i>p</i></b>	<b>Conclusion</b>
H1:	HCRO → HCRM	0.648	< 0.001	Supported
H2a:	HCRM → HRMI	0.541	< 0.001	Supported
H2b:	HCRM → HLP	-0.014	0.922	Not Supported
H3:	HRMI → HLP	0.527	< 0.001	Supported
H4:	HLP → HOP	0.792	< 0.001	Supported

Healthcare SC counterfeit risk orientation was found to have a significant direct positive effect on healthcare SC counterfeit risk mitigation. The findings therefore provide support for H1 at the 0.001 level of significance. Similarly, healthcare SC risk counterfeit risk mitigation was found to have a significant direct positive effect on healthcare SC risk management integration. Thus, H2a was supported at the 0.001 level of significance.

With respect to healthcare logistics performance, healthcare SC counterfeit risk mitigation had an insignificant direct positive effect, while healthcare SC risk management integration was found to have a significant direct positive effect. H2b is therefore not supported. H3, on the other hand, is supported at the 0.001 significance level.

Finally, healthcare logistics performance had a significant direct positive effect on healthcare organization overall performance. The findings thus provide support for H4.

### Mediation analysis

Based on the results obtained in the previous section, the mediating role of healthcare SC counterfeit risk management integration in the link between healthcare SC counterfeit risk

mitigation and healthcare logistics performance was further evaluated. A summary of the mediation analysis is displayed in Table 10.

**Table 10. Summary of mediation analysis**

<b>Effect</b>	<b>Direct</b>	<b>Indirect</b>	<b>Conclusion</b>
HCRM → HLP	-0.014	0.285**	Full Mediation

**Note:** \*\*  $p < 0.01$

The results show that, in the case of healthcare organizations, SC counterfeit risk management integration fully mediates the relationship between SC counterfeit risk mitigation and logistics performance. The mediation analysis suggests that healthcare SC counterfeit risk management integration explains most of the effect of healthcare SC counterfeit risk mitigation on healthcare logistics performance and, ultimately, on healthcare organization overall performance. These findings therefore confirm the critical mediating role of SC counterfeit risk management integration in the healthcare sector.

## DISCUSSION

This paper explored the relationships among SC counterfeit risk management and supply chain performance in the healthcare sector. SC counterfeit risk management was characterized by factors of healthcare SC counterfeit risk orientation, healthcare SC counterfeit risk mitigation and healthcare SC risk management integration, while supply chain performance was represented by healthcare logistics performance and healthcare organization overall performance. Healthcare SC counterfeit risk orientation was found to have a significant direct positive effect on healthcare SC counterfeit risk mitigation. Healthcare SC risk counterfeit risk mitigation had a significant direct positive effect on healthcare SC risk management integration. With respect to healthcare logistics performance, healthcare SC counterfeit risk mitigation had an insignificant direct positive effect, while healthcare SC risk management integration was found to have a significant direct positive effect. Finally, healthcare logistics performance had a significant direct positive effect on healthcare organization overall performance. Preliminary empirical results thus confirm the critical mediating role of SC counterfeit risk management integration in the healthcare sector.

### Theoretical implications

Our study contributes to the healthcare SCM theory in the following ways. First, until now, counterfeiting research has made little, if any, distinction between a healthcare organization's philosophy toward counterfeiting risks and specific actions taken to avoid or reduce the impact of counterfeiting on the HCSC. Our study advances understanding in this area by delineating the view toward counterfeiting within the HCSC. A healthcare organization's approach to counterfeit risk is conceptualized as distinct constructs. In this respect, two new constructs are identified and validated: healthcare supply chain counterfeit risk orientation and healthcare supply chain counterfeit risk mitigation.

Further, we consider the different effects of these two constructs in relation to supply chain risk management integration and both logistics and overall organization performance in the

healthcare sector. Our findings indicate there is merit in going beyond orientation alone and considering the implementation of specific actions to manifest a healthcare organization's philosophy toward counterfeiting.

Finally, the research offers an organization-level framework for managerial decision-making in the context of counterfeiting within the healthcare sector. Thus, our study advances knowledge of how organizations may address the challenging issue of counterfeiting in the HCSC.

### **Managerial implications**

There are some general guiding principles to be taken away from this research that apply to the HCSC and are of importance to supply chain managers in the healthcare sector. This research finds that integration of the HCSC is a key aspect of managing risk. Healthcare organizations that do well involve their suppliers in the process of risk detection and risk mitigation and encourage them to develop a structured and formal approach to supply chain risk management in general, and counterfeiting risk in particular. Successful healthcare organizations also reach out to customers in their supply chain with the identification and management of potential supply chain counterfeit risks.

When it comes to the negative impacts of counterfeiting, the study findings suggest that it is not enough to have an orientation toward counterfeit risk. In this respect, simply thinking a great deal about counterfeiting and being concerned about its impact in a healthcare organization's supply chain may not be enough. An orientation toward counterfeit risk does not necessarily translate into positive impacts on supply chain metrics and outcomes. Healthcare organizations must act on these concerns by formalizing their approach to counterfeiting. The process may involve having a person or group dedicated to the identification of counterfeiting and employing a formal process for analyzing and managing an incidence of counterfeiting, should it occur. This includes working with suppliers and customers in the HCSC as part of this process. As noted in the literature, managing risk involves identifying potential risks, estimating how likely they are to occur, assessing the severity of their impact on the supply chain if they do occur, mitigating the event should it occur, and then monitoring after the event [2, 71]. This formalized practice can achieve its full potential in an integrated HCSC.

This research demonstrates that formal counterfeit management systems that integrate across the HCSC can have a positive impact on logistics and overall healthcare organization performance. Consistency of these aspects of performance facilitate not only a smoother flow through the supply chain, but can also serve to reduce the bullwhip effect in a supply chain [59]. The study findings suggest that a better management of supply chain counterfeiting risk is associated with a more responsive, flexible and visible HCSC, as well as improved flow of information and execution of financial transactions. Other benefits include better overall performance (i.e., improved metrics related to profit margin, return on investment, customer satisfaction, and quality, as illustrated by H4) when compared to healthcare organizations that do not employ a formal integrated process to counterfeiting risk identification and mitigation. These different benefits can ultimately help increase an organization's value, thus improving competitive position [72].

International regulation of counterfeiting has helped some, but problems persist, and HCSC managers must remain vigilant. Supply chain risk management researchers and practitioners have proposed actions to deter and manage counterfeiting. These tend to fall into several general categories, including the following:

1. Use authentication technology along with supply chain collaboration to increase traceability [22, 26, 27, 48] (e.g., Harmonic Health Pharmaceutical Co. Ltd use of RFID tagging).
2. Focus more attention on communication, such as better brand marketing and/or educating of stakeholders/customers about counterfeiting risks [22, 25, 26] (e.g., the FDA's development of public service announcements regarding counterfeit drugs).
3. Focus on improving surveillance methods, such as searching web sites, monitoring channel distribution, etc. [22, 24, 26] (e.g., Louis Vuitton and Dior's use of web monitoring and sample web purchases). Organizations might also explore the deployment of big data sense-and-respond systems [73].
4. Make use of more frequent product evolution/innovation [25, 26] (e.g., Microsoft's innovations and consistent upgrades accompanied by copyright infringement or chip manufacturers that just moved on to higher-order models)
5. Other Actions: reward forward channel members for helping [24], pursue legal enforcement, withdraw from high risk markets (e.g., companies may sign a one-time-only agreement in a high-risk market/region and then retreat) [26], keep critical production in-house, and employ business processes that are hard to replicate [10].
6. Consider purchasing/co-opting offenders [25, 26] (e.g., Rovio's (Angry Birds) decision to cooperate with some Chinese counterfeiters and the purchase of Thai factories by legitimate businesses) .

HCSC managers must decide which specific approaches work best for their organizations and supply chains. One size does not fit all. However, whichever approaches a manager ultimately selects, formalized supply chain collaboration and integration is key to managing counterfeit risk and improving competitive position in the healthcare sector.

### **Limitations and future research**

A number of research limitations and future research directions must be discussed. The first limitation that should be pointed out is related to the fact that survey respondents were predominantly from the United States, limiting the generalizability of the study findings to different countries or regions. Empirical research on how HCSC counterfeit risk management impacts performance in the healthcare sector should be pursued in different geographic regions.

An additional limitation is related to the 'snapshot' nature of the study. In this respect, a longitudinal study would allow future research to investigate additional issues and factors such as the impact of HCSC counterfeit risk management on supply chain performance over time.

One final limitation is related to the survey scale items used in the study. In this respect, the use of actual supply chain performance metrics would be preferable over the use of items that represent managerial perceptions of HCSC counterfeit risk and performance metrics. These

limitations notwithstanding, the study findings represent a valid starting point for further empirical research on a current and relevant health care SCM topic.

## REFERENCES

1. Bak, O., *Supply chain risk management research agenda: From a literature review to a call for future research directions*. Business Process Management Journal, 2018. 24(2): p. 567-588.
2. Ho, W., et al., *Supply chain risk management: a literature review*. International Journal of Production Research, 2015. 53(16): p. 5031-5069.
3. Zepeda, E.D., G.N. Nyaga, and G.J. Young, *Supply chain risk management and hospital inventory: Effects of system affiliation*. Journal of Operations Management, 2016. 44(1): p. 30-47.
4. Clauson, K.A., et al., *Leveraging blockchain technology to enhance supply chain management in healthcare: An exploration of challenges and opportunities in the health supply chain*. Blockchain in Healthcare Today, 2018. 1: p. 1-12.
5. D'Amato, I. and T. Papadimitriou, *Legitimate vs illegitimate: the luxury supply chain and its doppelganger*. International Journal of Retail & Distribution Management, 2013. 41(11/12): p. 986-1007.
6. Regattieri, A., et al., *An innovative procedure for introducing the lean concept into the internal drug supply chain of a hospital*. The TQM Journal, 2018. 30(6): p. 717-731.
7. Cole, R.E., *What really happened to Toyota?* MIT Sloan Management Review, 2011. 52(4): p. 29-35.
8. Van Mieghem, J.A., *Risk management and operational hedging: an overview*, in *The Handbook of Integrated Risk Management in Global Supply Chains*, P. Kouvelis, Dong, L., Boyabatli, O. and Li, R., Editor. 2011, John Wiley & Sons Inc.: Hoboken, NJ. p. 13-49.
9. Blackhurst, J.V., K.P. Scheibe, and D.J. Johnson, *Supplier risk assessment and monitoring for the automotive industry*. International Journal of Physical Distribution & Logistics Management, 2008. 38(2): p. 143-165.
10. Chopra, S. and M.S. Sodhi, *Managing risk to avoid supply-chain breakdown*. MIT Sloan management review, 2004. 46(1): p. 53-61.
11. Harland, C., R. Brenchley, and H. Walker, *Risk in supply networks*. Journal of Purchasing and Supply management, 2003. 9(2): p. 51-62.
12. Punniyamoorthy, M., N. Thamaraiselvan, and L. Manikandan, *Assessment of supply chain risk: scale development and validation*. Benchmarking: An International Journal, 2013. 20(1): p. 79-105.
13. Samvedi, A., V. Jain, and F.T. Chan, *Quantifying risks in a supply chain through integration of fuzzy AHP and fuzzy TOPSIS*. International Journal of Production Research, 2013. 51(8): p. 2433-2442.
14. Tang, C. and B. Tomlin, *The power of flexibility for mitigating supply chain risks*. International Journal of Production Economics, 2008. 116(1): p. 12-27.
15. Tang, O. and S.N. Musa, *Identifying risk issues and research advancements in supply chain risk management*. International Journal of Production Economics, 2011. 133(1): p. 25-34.
16. Wildgoose, N., P. Brennan, and S. Thompson, *Understanding your supply chain to reduce the risk of supply chain disruption*. Journal of Business Continuity & Emergency Planning, 2012. 6(1): p. 55-67.

17. Wu, T., J. Blackhurst, and V. Chidambaram, *A model for inbound supply risk analysis*. Computers in Industry, 2006. 57(4): p. 350-365.
18. Zhao, L., et al., *The impact of supply chain risk on supply chain integration and company performance: A global investigation*. Supply Chain Management: An International Journal, 2013. 18(2): p. 115-131.
19. Staake, T., F. Thiesse, and E. Fleisch, *The emergence of counterfeit trade: a literature review*. European Journal of Marketing, 2009. 43(3/4): p. 320-349.
20. Swanson, D., et al., *An analysis of supply chain management research by topic*. Supply Chain Management: An International Journal, 2018. 12(3): p. 100-116.
21. Kwak, D.-W., et al., *Risk interaction identification in international supply chain logistics: Developing a holistic model*. International Journal of Operations & Production Management, 2018. 38(2): p. 372-389.
22. Berman, B., *Strategies to detect and reduce counterfeiting activity*. Business Horizons, 2008. 51(3): p. 191-199.
23. Howard, M.C., *Textile and Fur Labeling Legislation: Names, Competition, and the Consumer*. California Management Review, 1971. 14(2): p. 69-80.
24. Bush, R.F., P.H. Bloch, and S. Dawson, *Remedies for product counterfeiting*. Business Horizons, 1989. 32(1): p. 59-66.
25. Shultz, C.J. and B. Saporito, *Protecting intellectual property: Strategies and recommendations to deter counterfeiting and brand piracy in global markets*. The Columbia Journal of World Business, 1996. 31(1): p. 18-28.
26. Hoecht, A. and P. Trott, *How should firms deal with counterfeiting? A review of the success conditions of anti-counterfeiting strategies*. International Journal of Emerging Markets, 2014. 9(1): p. 98-119.
27. Basole, R.C. and M. Nowak, *Assimilation of tracking technology in the supply chain*. Transportation Research Part E: Logistics and Transportation Review, 2018. 114: p. 350-370.
28. Ilie, C. and V. Popa, *Efficient Healthcare Consumer Supply Chain Optimization*. Valahian Journal of Economic Studies, 2013. 4(3): p. 41-48.
29. Gardner, J.W., K.W. Linderman, and K.L. McFadden, *Managing quality crossroads in healthcare: An integrative supply chain perspective*. Quality Management Journal, 2018. 25(1): p. 2-17.
30. de Vries, J. and R. Huijsman, *Supply chain management in health services: an overview*. Supply Chain Management: An International Journal, 2011. 16(3): p. 159-165.
31. Akao, Y. and E.R. Chaplin, *Making hospitals more transparent*. Quality Management Journal, 2003. 10(3): p. 25-32.
32. Shanley, A., *Anticounterfeiting: In Search of the Unhackable*. Pharmaceutical Technology, 2018. 42(2): p. 56-58.
33. Widengren, S., *Serialization: The Final Countdown*. Pharmaceutical Technology Europe, 2017(March Supplement): p. 21-22.
34. Johnson, B. *Intermountain healthcare supply chain*. in *The 2015 Healthcare Supply Chain Conference*. 2015. New Orleans, LA.
35. Chakraborty, S. and D.D. Dobrzykowski, *Supply Chain Practices for Complexity in Healthcare: A Service-Dominant Logic View*. IUP Journal of Supply Chain Management, 2013. 10(3): p. 53-75.

36. Kim, S.-H. and I.-W.G. Kwon, *The study of healthcare supply chain management in United States: Literature review*. Management Review: An International Journal, 2015. 10(2): p. 34-56.
37. Duffy, M., *Is supply chain the cure for rising healthcare costs?* Supply Chain Management Review, 2009. 13(6): p. 28-35.
38. Smith, B.K., H. Nachtmann, and E.A. Pohl, *Improving healthcare supply chain processes via data standardization*. Engineering Management Journal, 2012. 24(1): p. 3-10.
39. VanVactor, J.D., *Cognizant healthcare logistics management: ensuring resilience during crisis*. International Journal of Disaster Resilience in the Built Environment, 2011. 2(3): p. 245-255.
40. McKone-Sweet, K.E., P. Hamilton, and S.B. Willis, *The ailing healthcare supply chain: a prescription for change*. Journal of Supply Chain Management, 2005. 41(1): p. 4-17.
41. Lee, S.M., D. Lee, and M.J. Schniederjans, *Supply chain innovation and organizational performance in the healthcare industry*. International Journal of Operations & Production Management, 2011. 31(11): p. 1193-1214.
42. Kabbaj, W. and D. Van Peteghen, *Reinventing the cold chain in a high-stakes market*. Pharmaceutical Technology, 2015. 27(2): p. 26-27.
43. McGrady, E., et al., *Emerging technologies in healthcare: Navigating risks, evaluating rewards*. Journal of Healthcare Management, 2010. 55(5): p. 353-364.
44. Mehrjerdi, Y.Z., *RFID-enabled healthcare systems: risk-benefit analysis*. International Journal of Pharmaceutical and Healthcare Marketing, 2010. 4(3): p. 282-300.
45. Alvarenga, A. and G. Tanev, *A Cybersecurity Risk Assessment Framework that Integrates Value-Sensitive Design*. Technology Innovation Management Review, 2017. 7(4): p. 32-43.
46. Casabona, C.M.R., et al., *International strategies in fighting against medicaments fraud and other similar offences. The MEDICRIME Convention*. Crime, Law and Social Change, 2017. 68(1-2): p. 95-122.
47. Chand, A.M. and M. Loosemore, *Hospital disaster management's understanding of built environment impacts on healthcare services during extreme weather events*. Engineering, Construction and Architectural Management, 2016. 23(3): p. 385-402.
48. Kwok, S., et al., *A counterfeit network analyzer based on RFID and EPC*. Industrial Management & Data Systems, 2010. 110(7): p. 1018-1037.
49. Enyinda, C.I. and J. Szmerekovsky, *Sense and respond supply chain: A prescription for mitigating vulnerability in the US pharmaceutical value chain*. Journal of Global Business Issues, 2008. 2(2): p. 95-103.
50. Wechsler, J., *FDA Seeks New Approach to Global Challenges*. Applied Clinical Trials, 2011. 20(8): p. 18-19.
51. Chircu, A., E. Sultanow, and S.P. Saraswat, *Healthcare RFID in Germany: an integrated pharmaceutical supply chain perspective*. Journal of Applied Business Research, 2014. 30(3): p. 737-752.
52. Barry, J., *Fake medicines: a global threat*. Nursing management (Harrow, London, England: 1994), 2014. 21(8): p. 17.
53. Bendul, J.C. and A.C. Skorna, *Exploring impact factors of shippers' risk prevention activities: A European survey in transportation*. Transportation Research Part E: Logistics and Transportation Review, 2016. 90: p. 206-223.



54. Alam, A., et al., *The mediating effect of logistics integration on supply chain performance: a multi-country study*. The International Journal of Logistics Management, 2014. 25(3): p. 553-580.
55. Kache, F. and S. Seuring, *Linking collaboration and integration to risk and performance in supply chains via a review of literature reviews*. Supply Chain Management: An International Journal, 2014. 19(5/6): p. 664-682.
56. Ketokivi, M.A. and R.G. Schroeder, *Perceptual measures of performance: fact or fiction?* Journal of Operations Management, 2004. 22(3): p. 247-264.
57. Ambulkar, S., J. Blackhurst, and S. Grawe, *Firm's resilience to supply chain disruptions: Scale development and empirical examination*. Journal of Operations Management, 2015. 33(1): p. 111-122.
58. Florio, T., *Exploring the relationship of supply chain risk management to quality management*, in *Quality Control and Assurance - An Ancient Greek Term Re-Mastered*, L.D. Kounis, Editor. 2017, IntechOpen. p. 135-154.
59. Chopra, S. and P. Meindl, *Supply Chain Management: Strategy, Planning and Operation*. 6th ed. 2016, Harlow, England: Pearson Education Limited.
60. Bozarth, C.C. and R.B. Handfield, *Introduction to Operations and Supply Chain Management*. 4th ed. 2016, Harlow, England: Pearson Education Limited.
61. Claassen, M.J.T., A.J. Van Weele, and E.M. Van Raaij, *Performance outcomes and success factors of vendor managed inventory (VMI)*. Supply Chain Management: An International Journal, 2008. 13(6): p. 406-414.
62. Tan, K.C., V.R. Kannan, and R.B. Handfield, *Supply chain management: Supplier performance and firm performance*. Journal of Supply Chain Management, 1998. 34(3): p. 2-9.
63. Dillman, D.A., *Mail and internet surveys: The tailored design method*. 2000, New York, NY: John Wiley & Sons, Inc.
64. Hair, J.F., C.M. Ringle, and M. Sarstedt, *PLS-SEM: Indeed a silver bullet*. Journal of Marketing Theory and Practice, 2011. 19(2): p. 139-152.
65. Henseler, J., et al., *Common beliefs and reality about PLS: Comments on Rönkkö and Evermann (2013)*. Organizational Research Methods, 2014. 17(2): p. 182-209.
66. Hair, J.F., et al., *A primer on partial least squares structural equation modeling (PLS-SEM)*. 2nd ed. 2016, Los Angeles, CA: Sage Publications.
67. Dijkstra, T.K. and J. Henseler, *Consistent partial least squares path modeling*. MIS Quarterly, 2015. 39(2): p. 297-316.
68. Fornell, C. and D.F. Larcker, *Evaluating structural equation models with unobservable variables and measurement error*. Journal of Marketing Research, 1981. 18(1): p. 39-50.
69. Henseler, J., C.M. Ringle, and M. Sarstedt, *A new criterion for assessing discriminant validity in variance-based structural equation modeling*. Journal of the Academy of Marketing Science, 2015. 43(1): p. 115-135.
70. Ringle, C.M., S. Wende, and J.-M. Becker, *SmartPLS 3*. 2015, SmartPLS GmbH: Boenningstedt, Germany.
71. Kouvelis, P., et al., *Integrated risk management: A conceptual framework with research overview and applications practice*, in *Handbook of Integrated Risk Management in Global Supply Chains*, P. Kouvelis, et al., Editors. 2011, John Wiley & Sons Inc.: Hoboken, NJ. p. 3-12.

72. Farris, M.T. and P.D. Hutchison, *Cash-to-cash: the new supply chain management metric*. International Journal of Physical Distribution & Logistics Management, 2002. 32(4): p. 288-298.
73. Choi, T.-M., C.-H. Chiu, and H.-K. Chan, *Risk management of logistics systems*. Transportation Research Part E: Logistics and Transportation Review, 2016. 90: p. 1-6.

**THE ROLE OF COLLABORATION AND EFFICIENCY ON FIRM PERFORMANCE:  
A SUPPLY CHAIN MANAGERS PERSPECTIVE**

Suman Niranjana, G. Brint Ryan College of Business, University of North Texas, 1155 Union Circle #311396, Denton, TX 76203, 940-565-3673, suman.niranjana@unt.edu  
Katrina Savitskie, College of Business, University of West Florida, 11000 University Parkway, Pensacola, FL 32514, 850-474-2329, ksavitskie@uwf.edu  
Saad Bani Hani, G. Brint Ryan College of Business, University of North Texas, 1155 Union Circle #311396, Denton, TX 76203, saad.banihani@unt.edu

**ABSTRACT**

In the contemporary global arena, sustained competitive advantage enables firms to maintain continuity within a highly competitive environment. Knowledge, innovation and supply chain capabilities are critical to outpace competitors for the organization to survive. Prior supply chain management studies indicate an increasing interest in supply chain collaboration efforts by examining the collaboration process and joint decision-making initiatives, along with techniques that lead to better agreements among firms. Firms pursue the aforementioned activities with the goal of improving performance across many dimensions, including better on-time delivery, improved inventory turns, reduced purchase cost, improved responsiveness, and reduced total cost. Collaboration between supply chain parties improves the shared logistics processes and enhances the efficiency of the supply chain which impacts firm performance.

This exploratory study was conducted to assist supply chain firms in understanding the role of Process Resource Collaboration, Joint Decision Making, and Agreement on Supply Chain Performance via the mediating role of Efficiency and the moderating role of Supply Chain Integration Tools. The authors examined how the interaction of the study's constructs impacts overall firm performance. The goal of this research was to improve the supply chain managers' understanding of where to invest their time and effort to achieve better firm performance. Covariance based structural equation modeling using LISREL 9.3 was conducted to support the hypothesized conceptual model and provide some recommendation for a future researcher. The model was tested with data collected from 105 experienced US-based supply chain managers.

# Authors Index

Aasheim, C.	169, 282, 311	Campion, L.	517, 542
Adair, C.	335, 419	Cannon, A.	313, 318
Adana, S.	911, 946	Carter, K.	520
Adeyemi-Bello, T.	743, 749	Cates, T.	336, 443
Adivar, B.	329, 340, 396, 463	CELIK, H.	911, 946
Adivar, M.	168	Cevikparmak, S.	911, 946
Ahmadi, M.	149, 189, 335, 419	Chacko, J.	520
Al Haddad, S.	907, 934	Chen, C.	336, 337, 443, 444, 541, 605
Alroobi, R.	166, 253	Chiang, W.	902
Amarasuriya, S.	789	Chin, A.	476, 481, 484, 500
Amoo, T.	530, 567	Chullen, C.	743, 749
Amponsah, A.	747, 783	Connolly, A.	540, 604
An, X.	337, 444	Crouch, A.	524, 556
Andrews, B.	308–311, 313–316, 318, 531, 581	Crumbly, J.	518, 636
Andrews, W.	310, 531, 581	Custer, S.	313, 318
Araz, O.	323	Czienskowski, U.	160
Aust, B.	5		
Azadian, F.	513	Dailey, R.	467
		Daniel, B.	541, 605
Baker, E.	522	Dasgupta, T.	329, 396
Baker, H.	517	Davis, L.	900
Bani Hani, S.	914, 976	Davis, T.	8, 54
Barabasi, I.	159, 236	Davis, Z.	333, 413
Baracskai, Z.	170	Decker, J.	535
Barnes, R.	7, 477	Dellana, S.	913, 954
Bathula, K.	158, 228	Deranek, K.	904, 926
Baynard, C.	903	DILEEPAN, P.	149, 189, 335, 419
Baynard, N.	903	Dillon, T.	524, 556
Belden, M.	790	Dong, S.	628
Benameur, K.	2, 15, 525	Dors, I.	796, 867
Benton, D.	310, 314	Douress, S.	788, 811
Benton, R.	482, 501	Downen, T.	6, 23
Bhadury, J.	909	Drye, S.	516
Billings, P.	642, 719		
Blue, A.	329, 396	Ebrahim, S.	322, 356
Bowers, M.	309	Ekezue, B.	165, 252, 329, 340, 396, 463
Brown, L.	329, 396	El-Rayes, N.	732, 740
Brown, R.	521, 733	Essounga-Njan, Y.	327, 328
Burke-Smalley, L.	519		
Bushelle Edghill, J.	329, 340, 396, 463	Farhangi, H.	899
Butler, F.	519	Fatima, A.	169, 282
		Franck, D.	793, 846
Camm, J.	309	Frank, R.	159, 236

---

Frazier, J.	910, 945	Jih, K.	633
Friedman, H.	530, 567	Johnson, P.	339, 456
Froehle, C.	324	Johnson-Synder, A.	10, 89, 151, 220
Galluch Schlosser, P.	634, 692	Jones, E.	476, 481, 484, 500
Gandy, A.	793, 846	Jones, N.	642, 719
Garsombke, T.	539	Jones, T.	328
Gavidia, J.	161, 251	Junglas, I.	154, 226
Gbongli, K.	747, 783	Kadlec, C.	551
Gerschberger, M.	912	Kang, T.	541, 605
Gillion, H.	338, 445	Karbasi Kheyr, A.	795, 866
Glackin, C.	168	Karim, M.	166, 253
Gong, B.	734	Kasten, J.	629, 654
Gregory, A.	797, 879	Kaur, J.	9, 65
Grunhagen, M.	731, 738	Keeling, K.	157, 308
Guazzini, A.	744	Keli, F.	905
Guo, J.	479, 486, 643, 726	Kemme, D.	5
Gupta, U.	534	Kerski, J.	552
Hackbarth, G.	308, 332, 334, 402	Kheirandish, R. (Cl )	160
Hall, K.	734	Killingsworth, B.	10, 89, 151, 220
hamilton, b.	797, 879	Kim, D.	514, 554
Hammond, K.	541, 605	Kim, M.	466, 472
Hanks, G.	550, 624	Kim, S.	6, 23
Harris, A.	329, 396	King, M.	799
Hartley, M.	154, 226	King, R.	532, 590
Hasbrouck, R.	523, 555	Kiser, S.	545, 550, 621, 624
Haselden, L.	794, 855	Kiyoungh, J.	901, 916
Hazzard, D.	547	Kleinow, J.	5
Heiens, R.	746, 773	Kline, W.	521, 733
Helms, M.	149, 189	Kolakowski, M.	322, 332, 356, 402
Hendrix, L.	311	Koohang, A.	478, 485
Hester, P.	150, 211	Koong, K.	155, 529, 566
Hinterplattner, M.	798, 890	Korovyakovskaya, I.	736
Hoopes, B.	313, 318	Kostova, K.	785, 803
Hsieh, C.	156, 227	Kros, J.	913, 954
Huang, T.	323	Kunuria, R.	735, 741
Huff, L.	340, 463	Kutlu, G.	634, 692
Hughes, R.	167, 281	Larsson, C.	546
Iyengar, D.	789	Lawler, J.	321, 325, 342, 368
J. Ladeira, W.	744	Lending, D.	517, 527
Jackson, Jr., E.	465	Leshner, A.	785, 803
Jacob, B.	148, 174	Lewellyn, P.	526
Jae-Dong, H.	901, 916	Li, Y. (James Madison University )	469
Jeong, J.	909	Li, Y. (University of Tennessee )	480, 499
Jewett, J.	524, 556	Lin, B.	152
Ji, H.	635	Little, M.	327
		Little, P.	476, 481, 484, 500

---

---

Liu, H.	786, 810	Okunade, A.	11, 97
Liu, L.	155, 529, 566	Padgett, C.	8, 54
Liu, Y.	628	Paliszkievicz, J.	478, 485
Lnu, K.	158, 228	Park, C.	514, 554
Lowry, G.	536	Passage, S.	334
Lu, Y.	5	Pelaez, A.	631, 669
lu, y.	162	Pelcher, J.	468, 473
Lyberger, M.	470	Pendli, N.	627, 645
MacLeod, K.	515	Petkewich, M.	315
Madarasu, L.	787	Pfitzner, B.	12, 123
Malhotra, D.	3, 16, 640, 709	Pinto, D.	744
Malhotra, R.	3, 16, 640, 709	Pittman, J.	322, 356
Malliaris, A.	13, 134	Ponomarov, S.	906
Malliaris, M.	13, 134	Possinger, M.	465
Marshall, B.	546	Potcner, K.	312, 314
Matsui, Y.	908, 944	Prasad, S.	163
Mauro, F.	913, 954	Price, S.	327
Mazzola, J.	340, 463	Qin, H.	155
McInerney, M.	537, 602	Qin, Z.	902
McLemore, N.	788, 811	Rasnick, E.	551
McOsker, C.	801, 891	Reed, A.	533, 591
Metcalf, A.	331, 398	Reeg, S.	907, 934
Miller, K.	539	Rehm, S.	154, 226
Miller, T.	791, 820	Rhee, S.	732, 735, 740, 741
Mills, L.	340, 463	Richardson, R.	903
Mishra, I.	800	Ritchie, W.	535, 544, 546, 552, 612
Mitri, M.	164	Rogers, P.	516
Moatari-Kazerouni, A.	330, 397	Roulhac, A.	799
Moreno, T.	735, 741	Rowe, W.	913, 954
Mousavi, S.	160	Russell, R.	902
Mumbower, S.	167, 281	Sajeesh, S.	323
Munn, J.	8, 54	Salaman, B.	732, 740
Mustafa, M.	4	Salvato, N.	544, 612
Mutchler, L.	543, 611	Samuel, J.	631, 669
Narayanaswamy, R.	746, 773	Sanchez, D.	904, 926
Nardi, V.	744	Sandhu, R.	171, 292
Nath, A. (Florida State University )	641	Sato, O.	908, 944
Nath, A. (Georgia Gwinnett College )	641	Saunders, O.	340, 463
NAUSS, R.	172	Savitskie, K.	914, 976
Newland, F.	338, 445	Schaer, K.	468, 473
Nilakantan, R.	789	Schmidt, E.	904, 926
Niranjan, S.	914, 976	Schrader, P.	166, 253
North, J.	172	Schupp, R.	903
Nydick, R.	3, 16	Scott, R.	315
O'Malley, J.	638	Scrogam, C.	544, 612
Obremski, J.	792		

---

---

Sebastianelli, R.	316	Venkatesh, S.	531, 581
Selassie, H.	4	Vines, T.	156, 227
Shahzaad, A.	544, 612	Walker, S.	523, 555
Shaw, A.	794, 855	Wang, J.	480, 499
Shona, M.	516, 900	Wang, P. (James Madison University )	479, 486, 643,
Shropshire, J.	482, 501, 627, 645		726
Sluder, L.	533, 591	Wang, P. (Texas A&M University at Galveston )	310
Smith, C.	330, 397	Ward, C.	793, 846
Smith, M.	539	Ward, L.	538
Smith, S.	308, 315	Wei, J.	628, 635, 642, 719
Song, Q.	745, 760	Weiner, R.	903
Spillan, J.	639	Weistroffer, H.	171, 292
Stanley-Brown, J.	171, 292	Wen, H.	155, 529, 566
Starr, C.	632, 678	White, C.	799
Stephan, D.	309, 316	Whitehead, K.	910, 945
Stevens, S.	467	Whiteside, M.	313, 318
Strole, C.	731, 738	Wimmer, H.	169, 282
Sundaresan, S.	637, 705	Winfield, J.	528
Sunita, A.	531, 581	Winston, E.	631, 669
Swart, W.	515	Wolfe, A.	797, 879
sweeney, k.	465	Wolverton, C.	549
Tamimi, N.	316	Wostbrock, A.	788, 811
Tappert, C.	148, 158, 159, 174, 228, 236	Wray, B.	315
Tarakci, H.	548, 623	Wynne, A.	522
Taylor, M.	336, 337, 443, 444	Xi, X.	743, 749
Teasley, W.	900	Yang, C.	153
Teixeira, R.	744	Yang, J.	745, 760
Thomas, W.	639	Yasemin, T.	548, 623
Thompson, M.	520	You, H.	11, 97, 326, 369, 788, 811
Tokman, M.	535	Zaino, M.	550, 624
Torabi, E.	324	Zhang, H.	630
toth-haasz, g.	170	Zhang, Y.	529, 566
Trendafilova, S.	468, 473	Zhang, Z.	637, 705
Trifts, J.	9, 65	Zheng, A.	788, 811
Trimi, S.	735, 741	Zheng, C.	9, 65
Uvet, H.	911, 946	Zhu, Z.	310, 314, 549
Vaziri, B.	467		

---





